

eduard

LIMITED EDITION



MiG-21bis
around the World

1
48

11135 - NAVI

ATTENTION



UPOZORNĚNÍ



ACHTUNG



ATTENTION



注意



Carefully read instruction sheet before assembling. When you use glue or paint, do not use near open flame and use in well ventilated room. Keep out of reach of small children. Children must not be allowed to suck any part, or pull vinyl bag over the head.



Před započítím stavby si pečlivě prostudujte stavební návod. Při používání barev a lepidel pracujte v dobře větrané místnosti. Lepidla ani barvy nepoužívejte v blízkosti otevřeného ohně. Model není určen malým dětem, mohlo by dojít k požití drobných dílů.

INSTRUCTION SIGNS * INSTR. SYMBOLS * INSTRUKTION SINNBILDEN * SYMBOLES * 記号の説明

OPTIONAL
VOLBABEND
OHNOUTSAND
BROUSITOPEN HOLE
VYVRTAT OTVORSYMETRICAL ASSEMBLY
SYMETRICKÁ MONTÁŽREMOVE
ODRÍZNOUTREVERSE SIDE
OTOČITAPPLY EDUARD MASK
AND PAINT
POUŽIT EDUARD MASK
NABARVIT

PARTS



DÍLY



TEILE



PIÈCES



部品

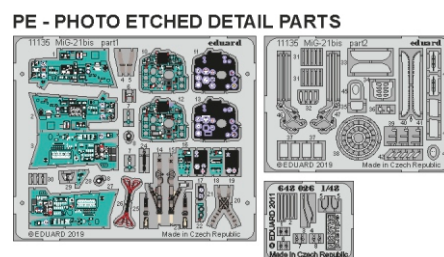
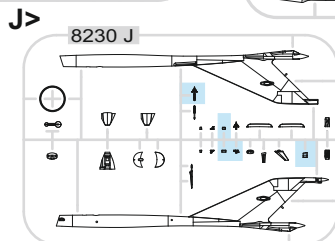
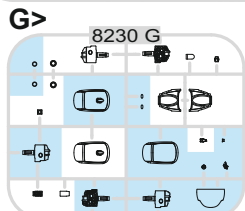
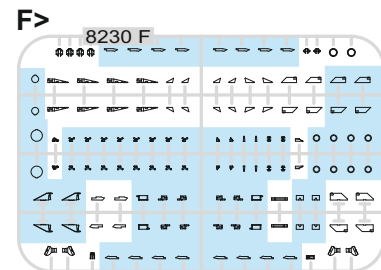
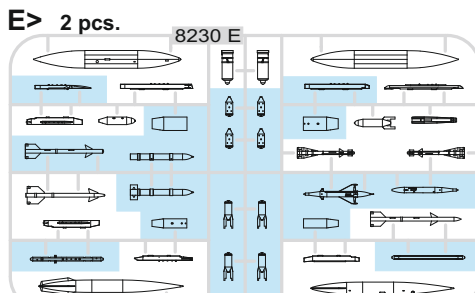
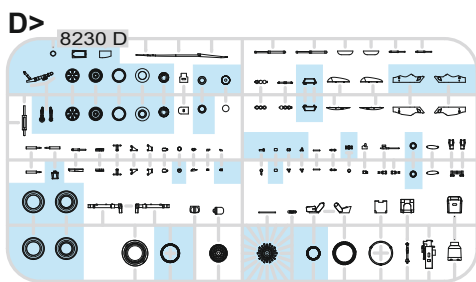
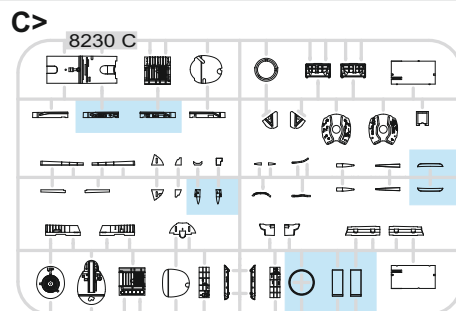
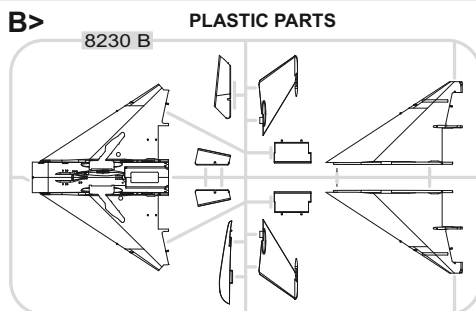
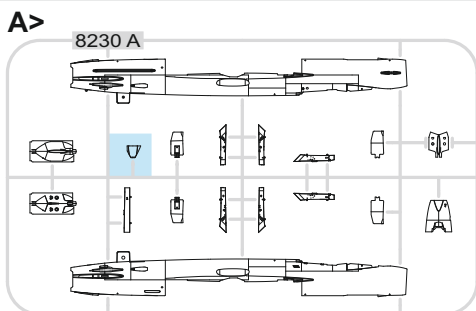

RP - RESIN PARTS



R1 2 pcs.



R2



R3



R4 2 pcs.



R6



R7



R8



R9



R10



R11

-Parts not for use. -Teile werden nicht verwendet. -Pièces à ne pas utiliser. -Tyto díly nepoužívejte při stavbě. - 使用しない部品

COLOURS



BARVY



FARBEN



PEINTURE



色

| GSI Creos (GUNZE) | | MISSION MODELS | |
|-------------------|----------|----------------|-----------------|
| AQUEOUS | Mr.COLOR | PAINTS | |
| H1 | C1 | MMP-001 | WHITE |
| H2 | C2 | MMP-047 | BLACK |
| H3 | C3 | MMP-003 | RED |
| H4 | C4 | MMP-007 | YELLOW |
| H5 | C5 | MMP-048 | BLUE |
| H7 | C7 | MMP-002 | BROWN |
| H8 | C8 | | SILVER |
| H11 | C62 | MMP-001 | FLAT WHITE |
| H12 | C33 | MMP-047 | FLAT BLACK |
| H26 | C66 | | BRIGHT GREEN |
| H27 | C44 | | TAN |
| H47 | C41 | MMP-012 | RED BROWN |
| H51 | C11 | MMP-063 | LIGHT GULL GRAY |
| H53 | C13 | | NEUTRAL GRAY |
| H58 | C27 | MMP-059 | INTERIOR GREEN |
| H67 | C115 | MMP-057 | LIGHT BLUE |
| H70 | C60 | MMP-056 | GRAY |
| H72 | C22 | MMP-078 | DARK EARTH |
| H77 | C137 | MMP-040 | TIRE BLACK |
| H81 | C55 | MMP-023 | KHAKI |
| H82 | C32 | | DARK GRAY |
| H84 | C42 | | MAHOGANY |
| H90 | C47 | | CLEAR RED |

| GSI Creos (GUNZE) | | MISSION MODELS | |
|-------------------------|----------|----------------|-------------------------|
| AQUEOUS | Mr.COLOR | PAINTS | |
| H94 | C138 | | CLEAR GREEN |
| H302 | C302 | | GREEN |
| H303 | C303 | MMP-066 | GREEN |
| H305 | C305 | MMP-084 | GRAY |
| H306 | C306 | MMP-118 | MEDIUM GRAY |
| H308 | C308 | MMP-073 | GRAY |
| H310 | C310 | MMP-060 | BROWN |
| H318 | C318 | MMP-070 | RADOME |
| H332 | C332 | | GRAYISH BLUE |
| H337 | C337 | | LIGHT AIRCRAFT GRAY |
| H418 | C118 | MMP-055 | LIGHT BLUE |
| | C19 | | SANDY BROWN |
| | C136 | MMP-032 | RUSSIAN GREEN |
| | C391 | | INTERIOR TURQUISE GREEN |
| Mr.METAL COLOR | | METALLICS | |
| | MC213 | MMM-006 | STEEL |
| | MC214 | MMM-001 | DARK IRON |
| | MC218 | MMM-003 | ALUMINIUM |
| Mr.COLOR SUPER METALLIC | | METALLICS | |
| | SM206 | MMC-001 | CHROME SILVER |
| Mr.COLOR GX | | METALLICS | |
| | GX05 | | SUSIE BLUE |

- 1** = **H11 MMP C62 001** - MARKING **A**
FLAT WHITE
- 1** = **H51 MMP C11 063** - MARKINGS **B;D;E;F;G**
LIGHT GULL GRAY
- 1** = **H57 MMP C115 057** - MARKING **C**
LIGHT BLUE

OPTIONAL:
decal 99, 100 ? decal 105, 106
decal 105, 106 -
MARKING **A** ONLY

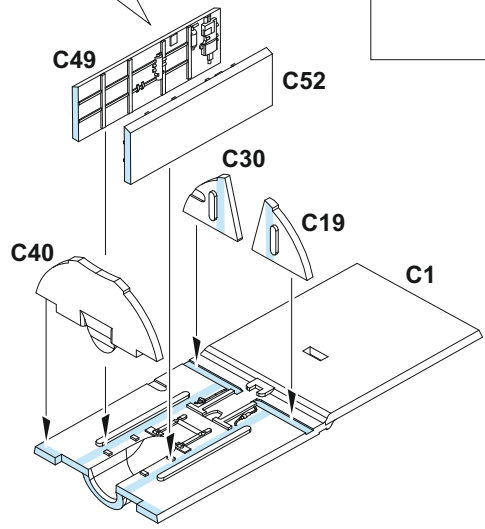
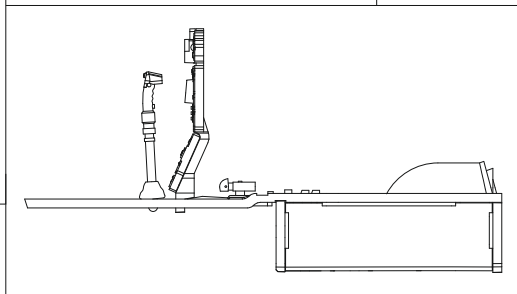
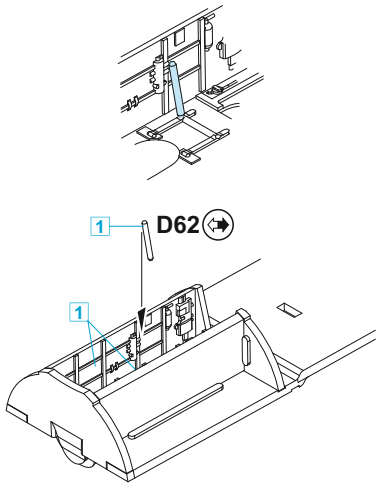
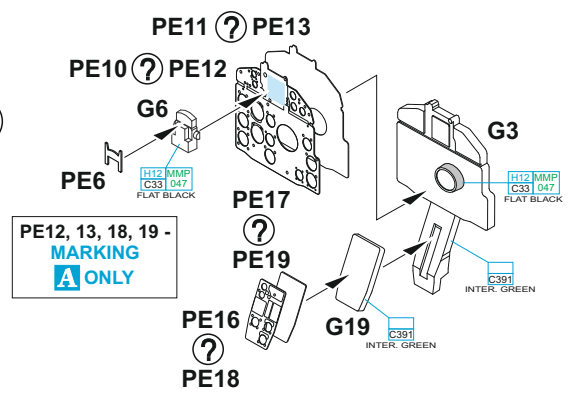

D20 - OPEN
CANOPY ONLY

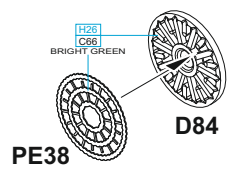
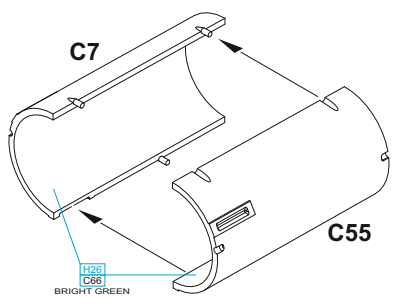
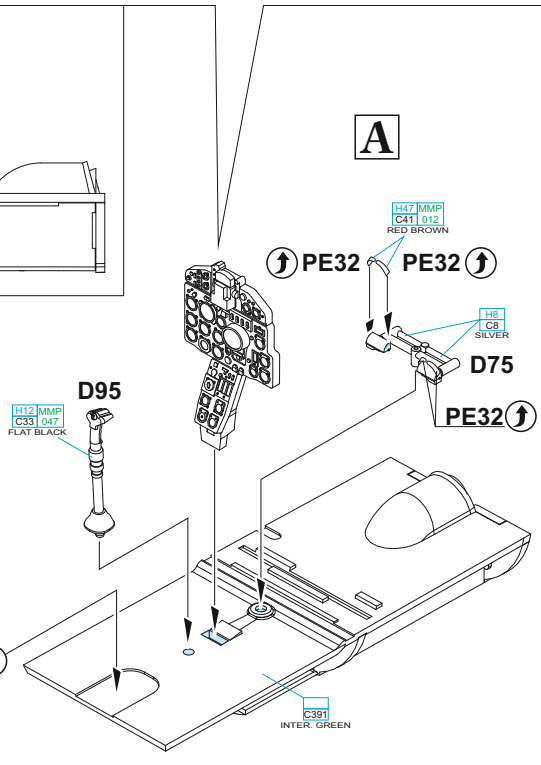

B

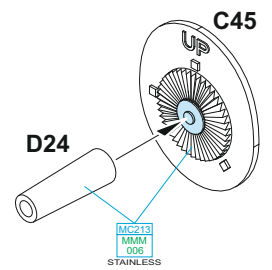
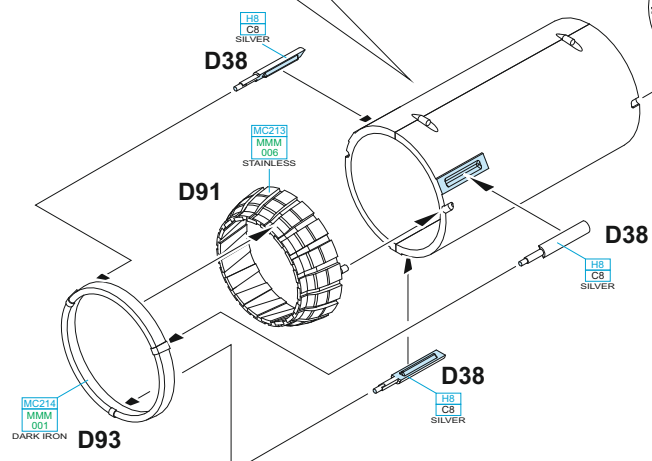
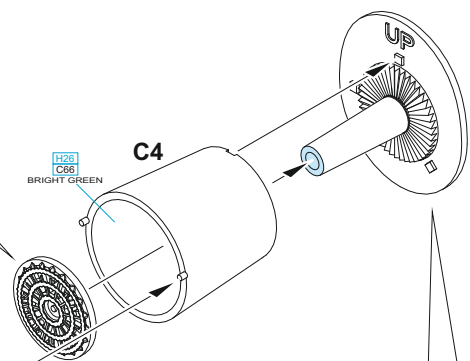

C

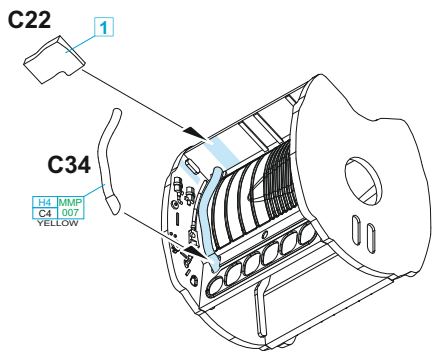
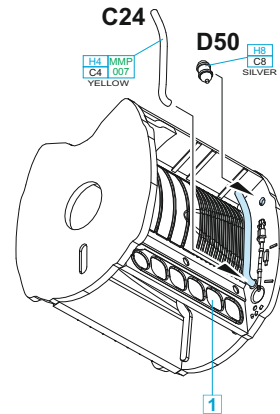
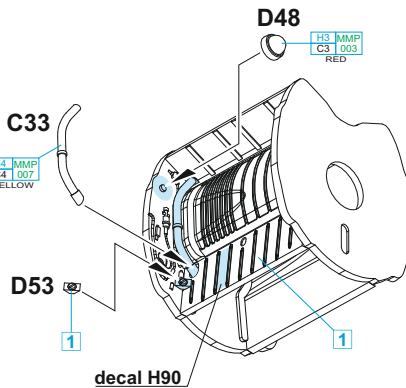
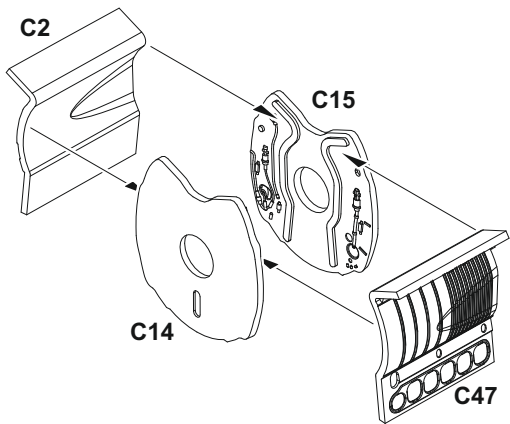

decal 104 - MARKING A ONLY

decal 98 ? decal 104 plastic

PE3, - MARKING A ONLY

PE3 (up arrow) ? PE27

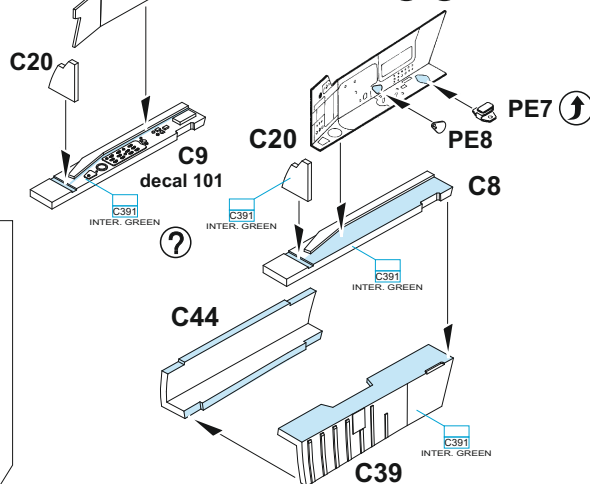

C42 PE3 ? PE27 A18

D

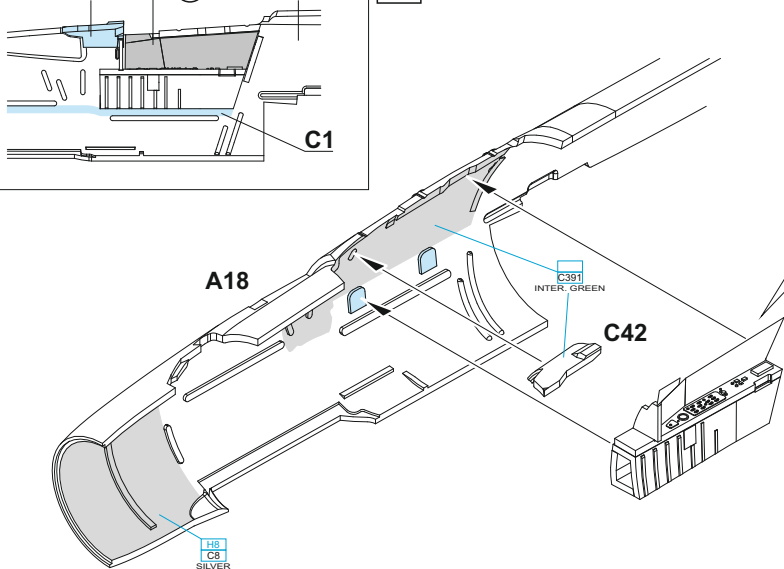

PE1 ? PE2

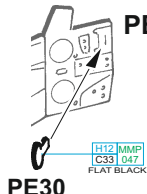

decal 103 - MARKING A ONLY

decal 97 ? decal 103 plastic

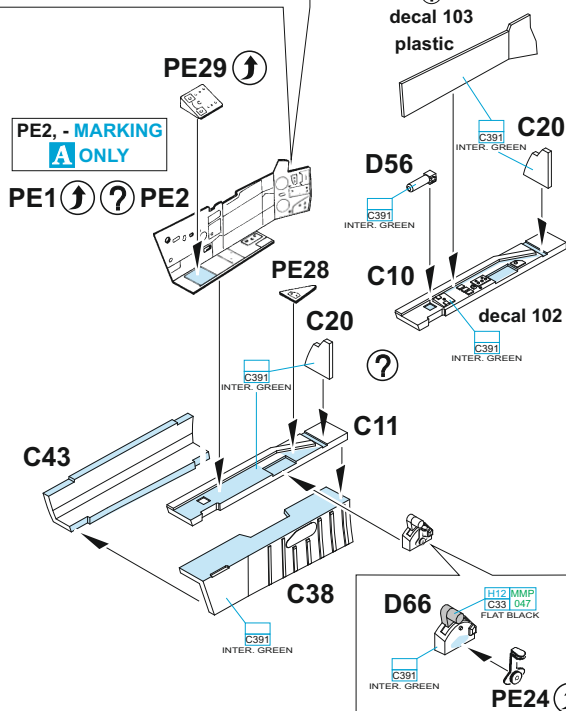

A1 PE1 ? PE2 C41

E

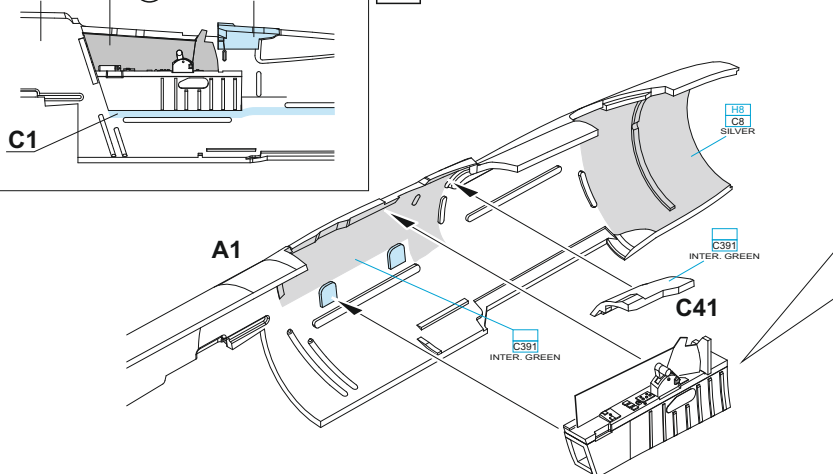

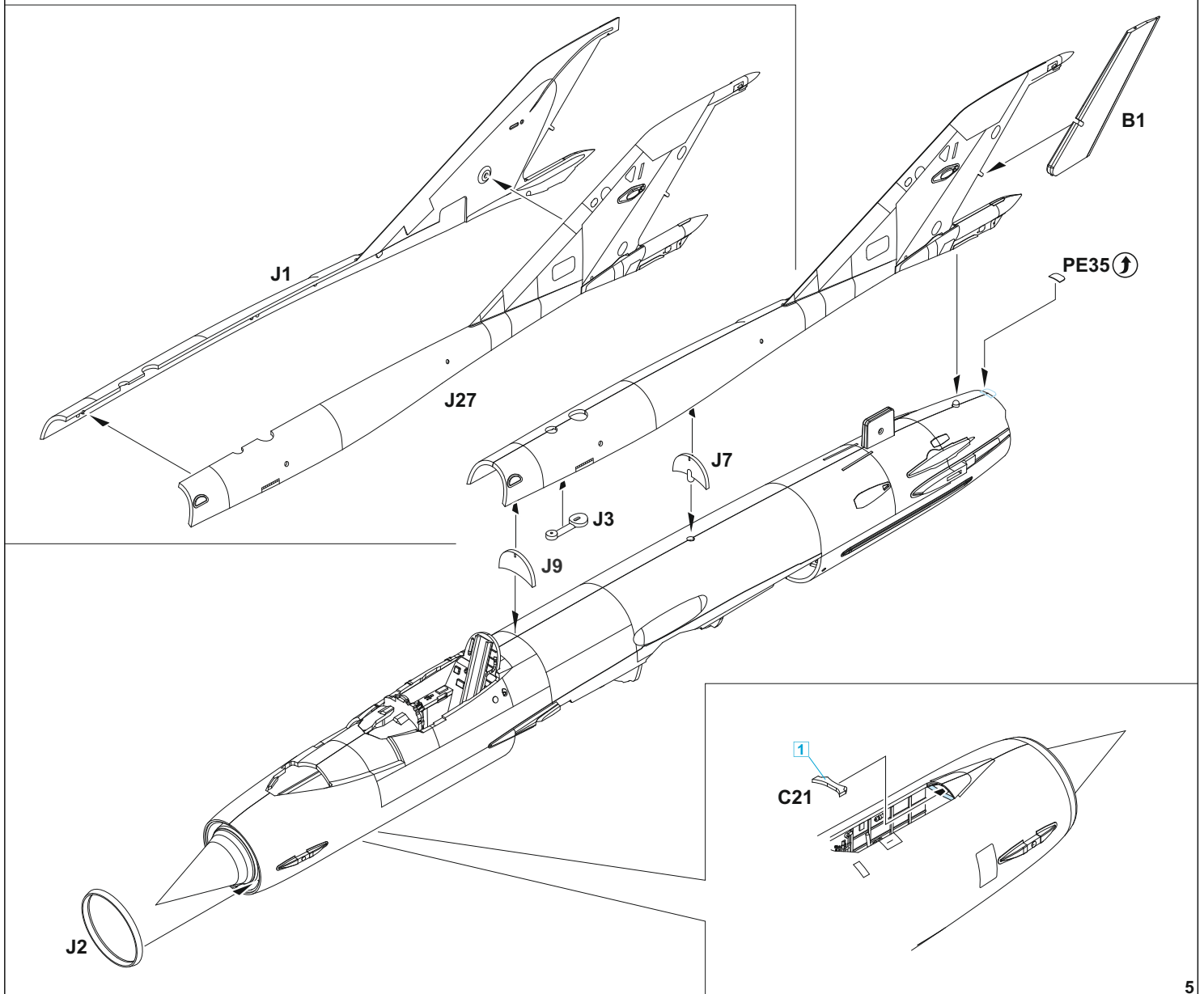
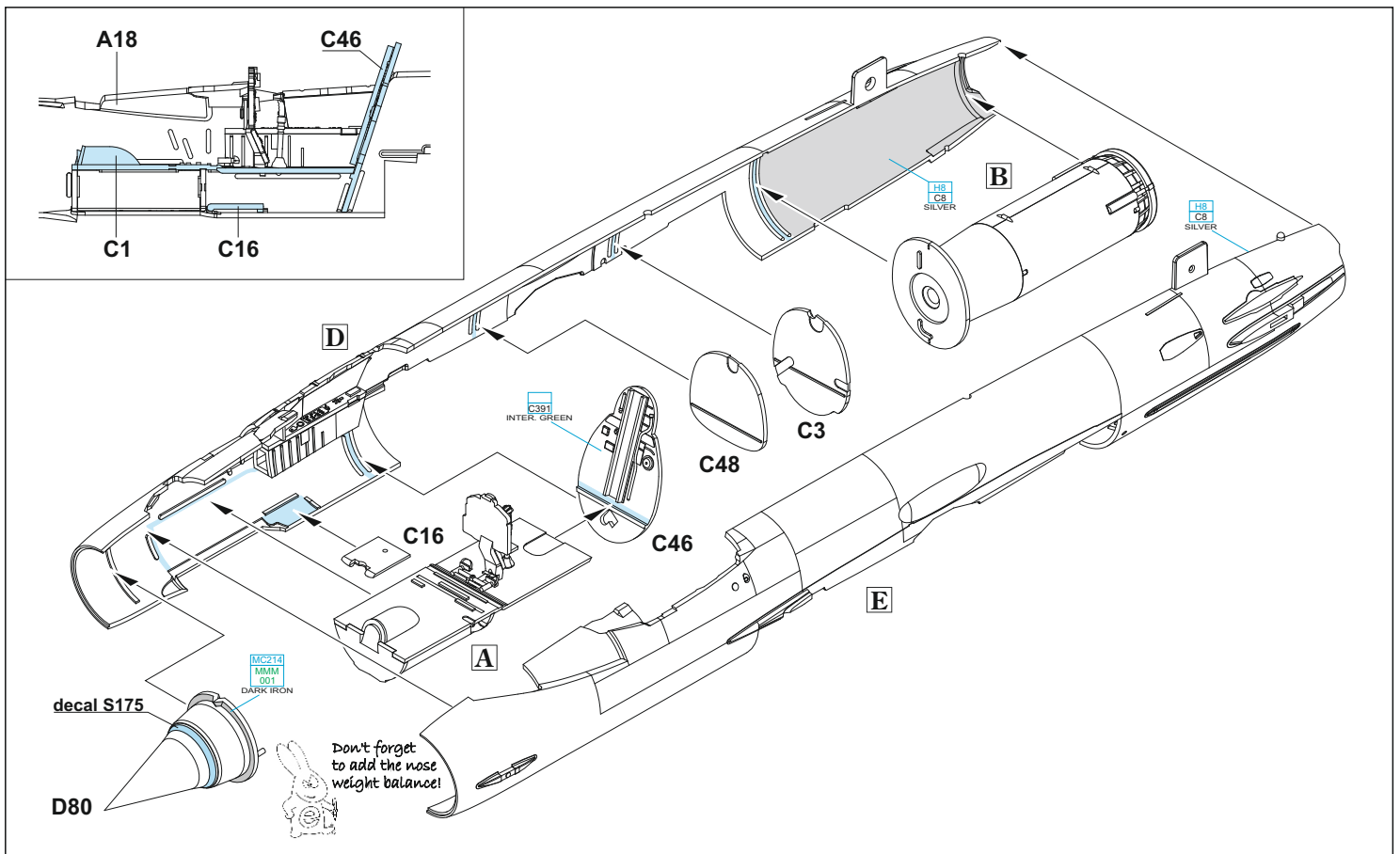

**FOR OPEN AIR BRAKES ONLY
JEN PRO OTEVŘENÉ ŠTÍTY**

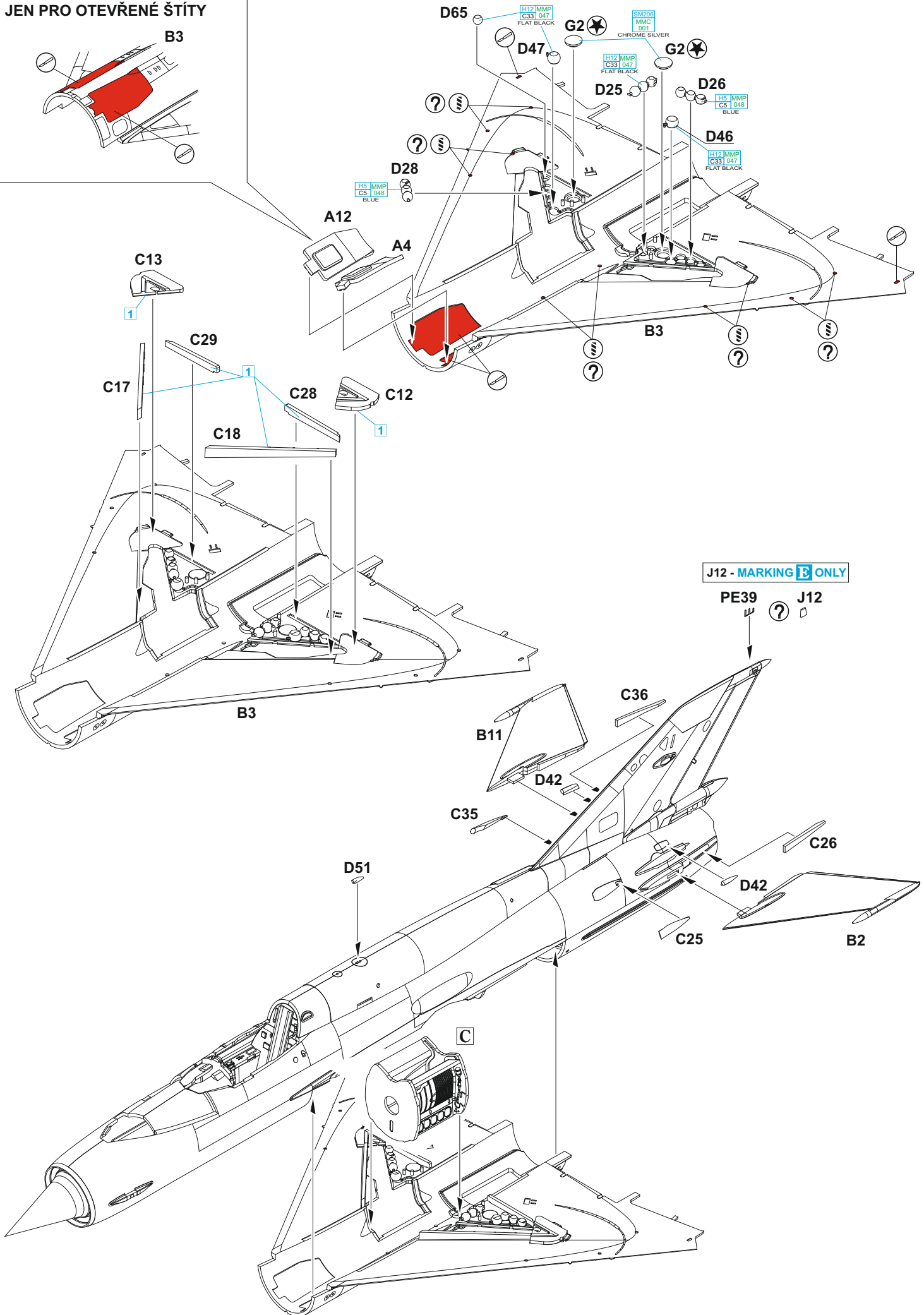
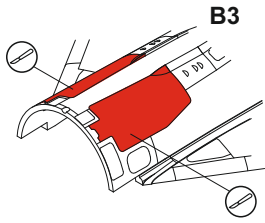

- 2** = 337
C37 - MARKING **A**
GRAYISH BLUE
 - 151
C11 MMP 083 - MARKINGS **B;D;E;F;G**
LIGHT GULL GRAY
 - 157
C15 MMP 057 - MARKING **C**
LIGHT BLUE
-
- 308
C308 MMP 073 - MARKING **A**
GRAY
 - 157
C15 MMP 057 - MARKINGS **B;C**
LIGHT BLUE
 - 151
C11 MMP 083 - MARKINGS **D;E;F;G**
LIGHT GULL GRAY
-
- 26
C66 - MARKINGS **A;B;D;E;F;G**
BRIGHT GREEN
 - 12
C2 MMP 047 - MARKING **C**
BLACK

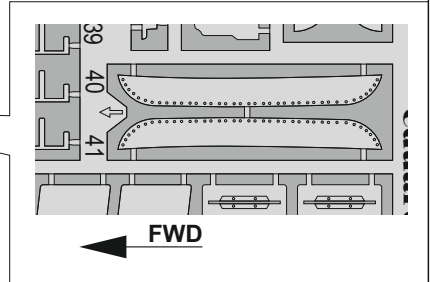
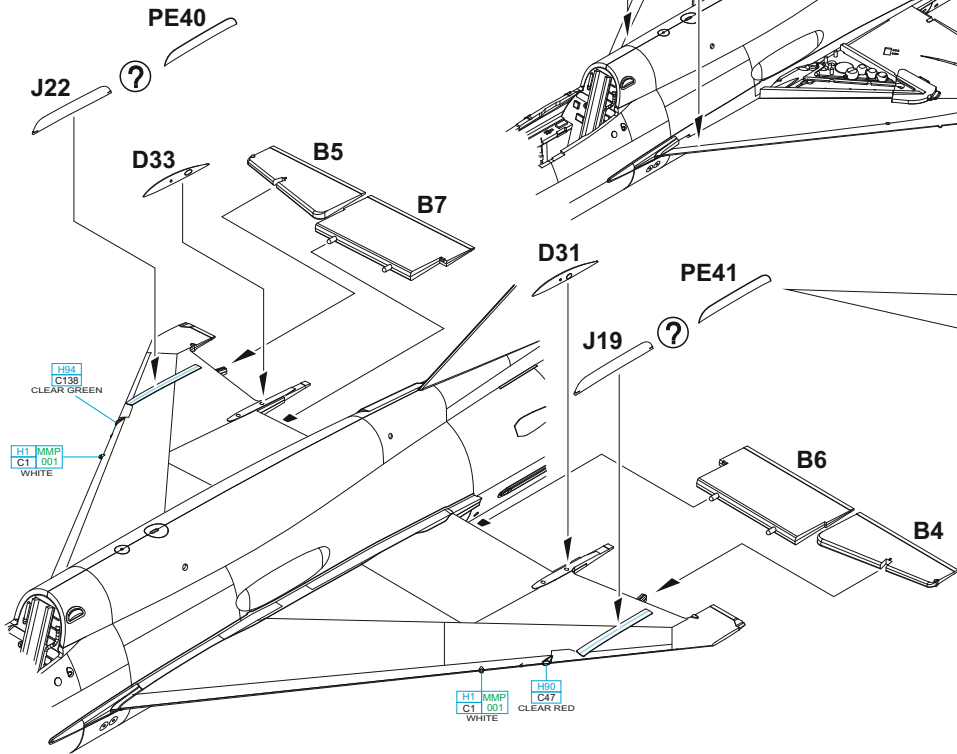
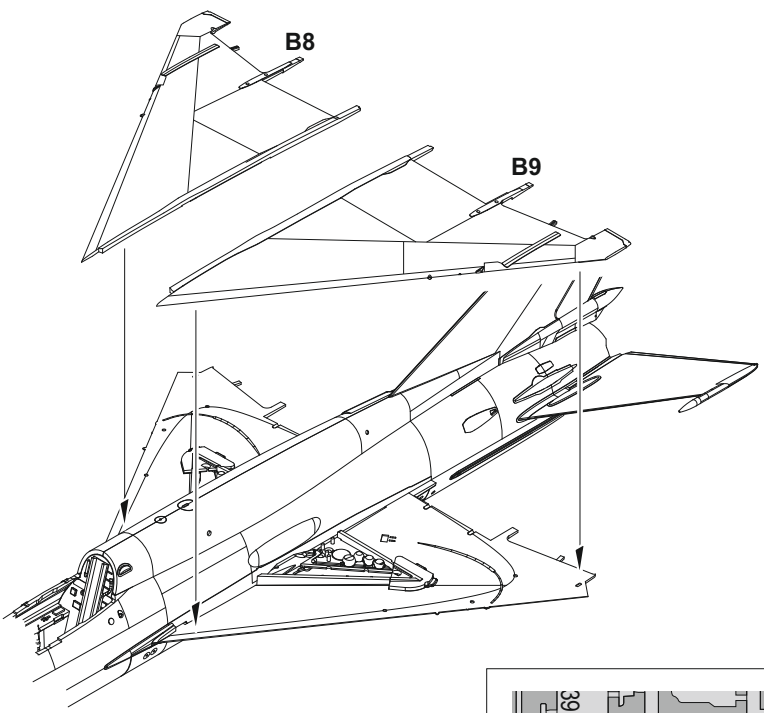

MARKING A ONLY

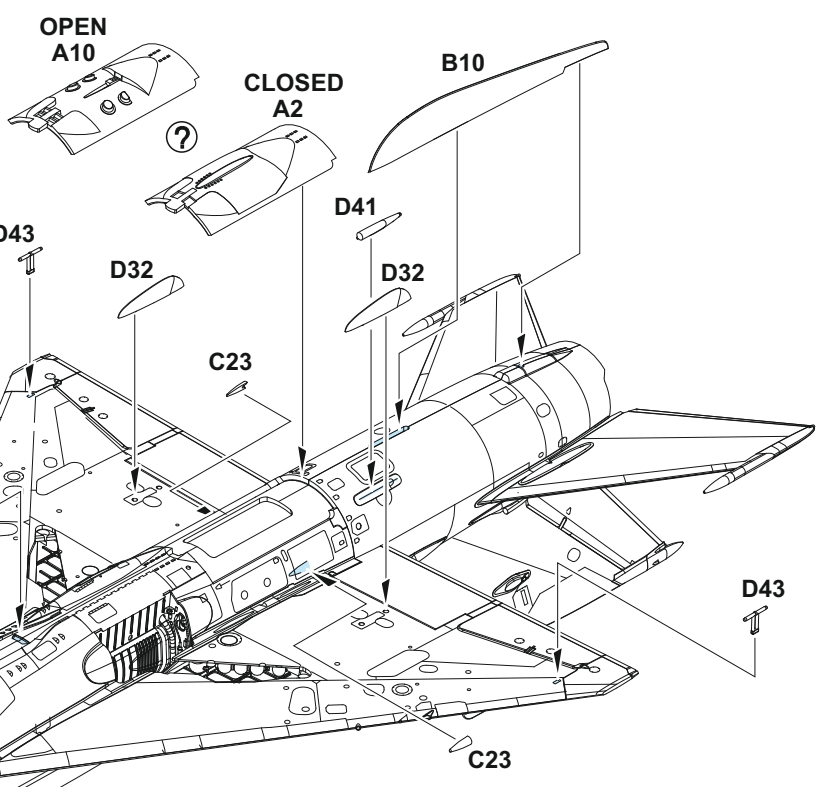
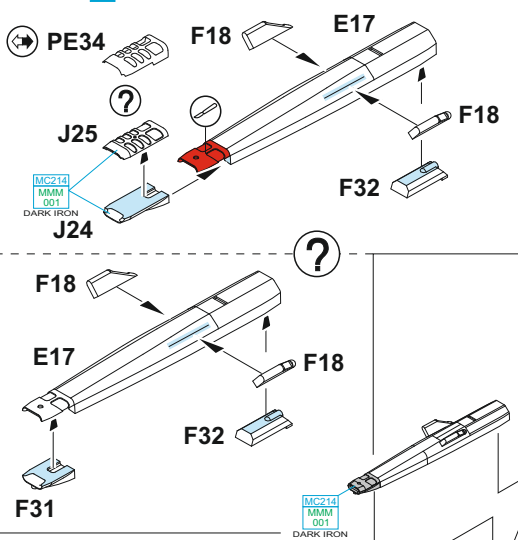

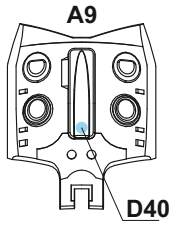

OPEN
?

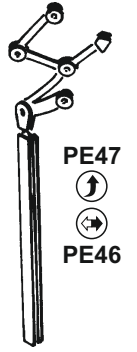
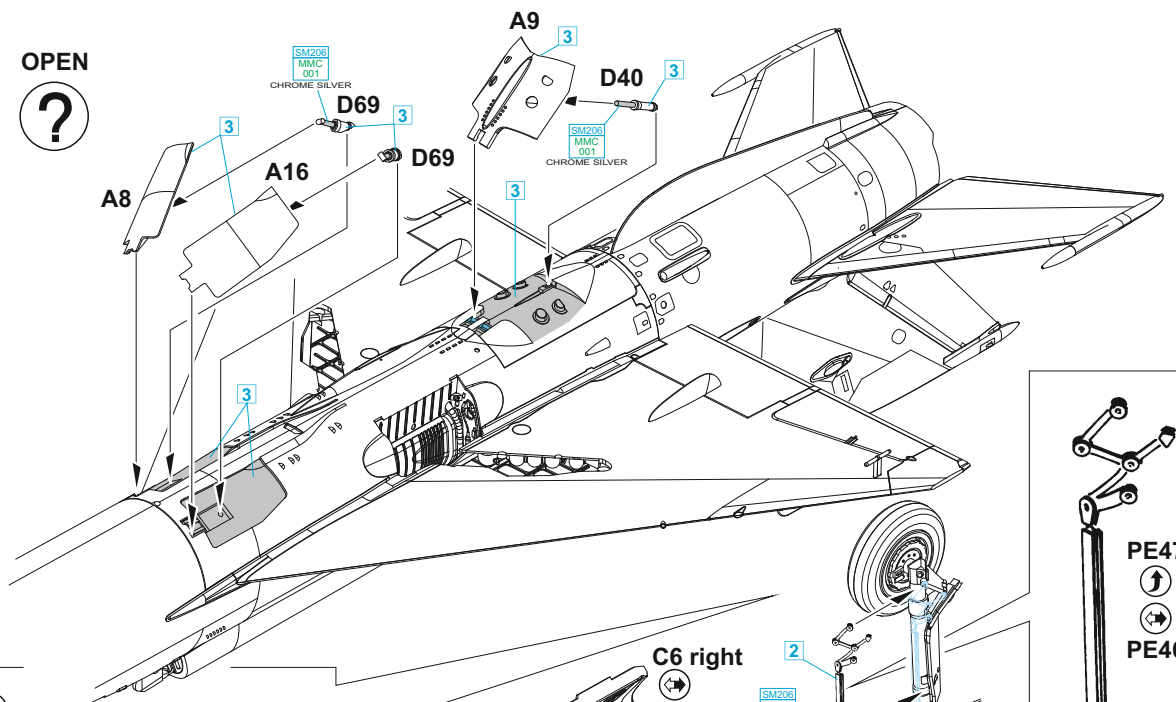

eduard BRASSIN 648026

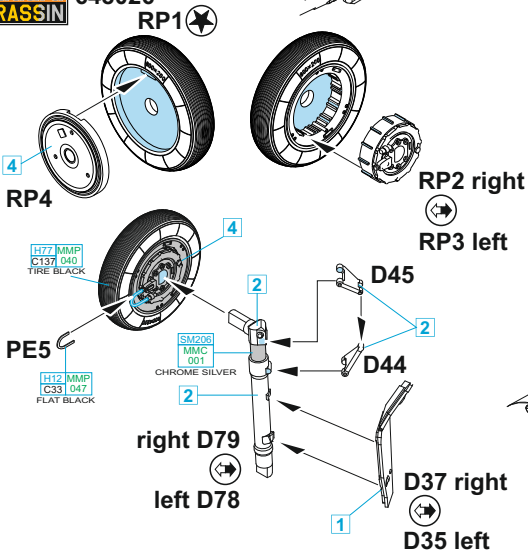

eduard BRASSIN 648026

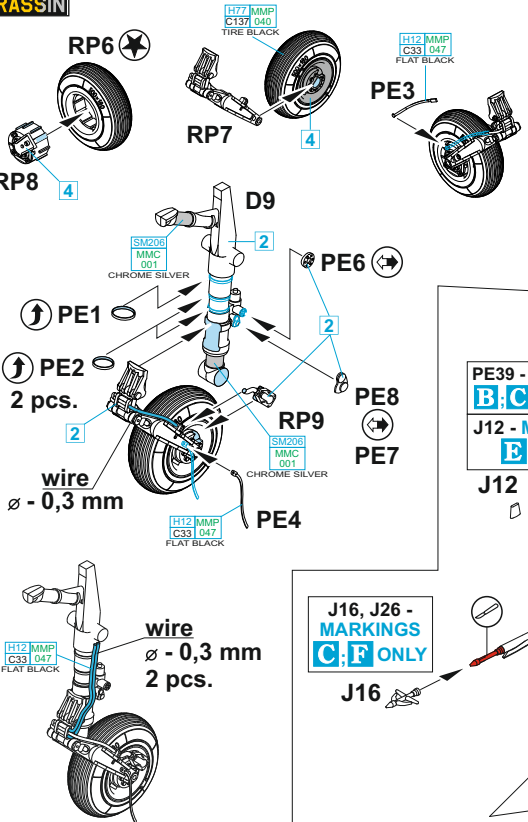

PE39 - MARKINGS
B, C, D, F, G
J12 - MARKING
E ONLY

J16, J26 -
MARKINGS
C, F ONLY

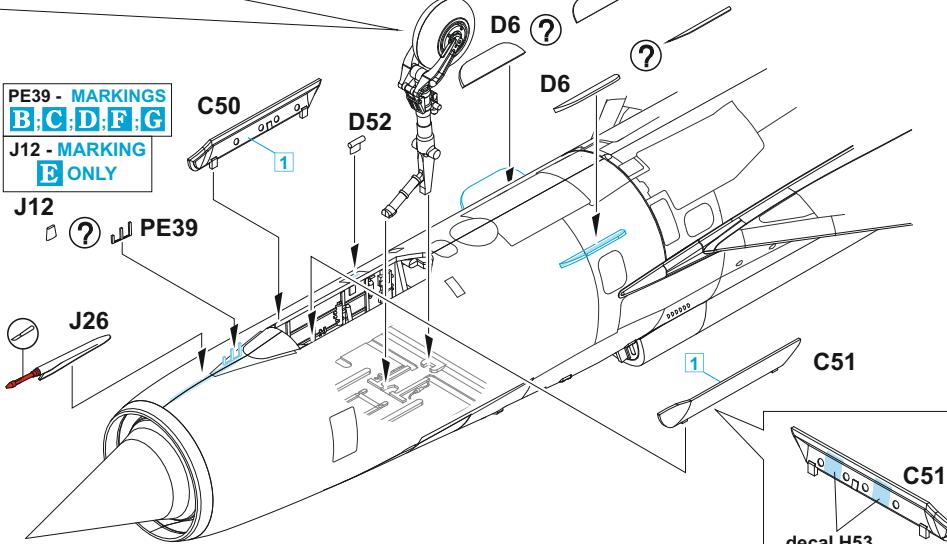
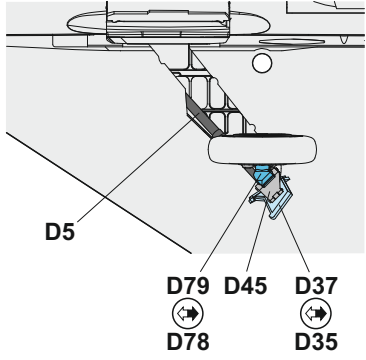
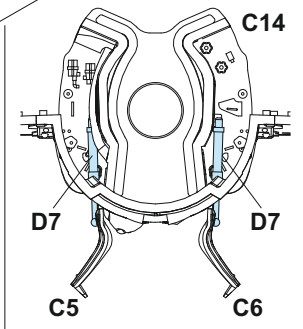
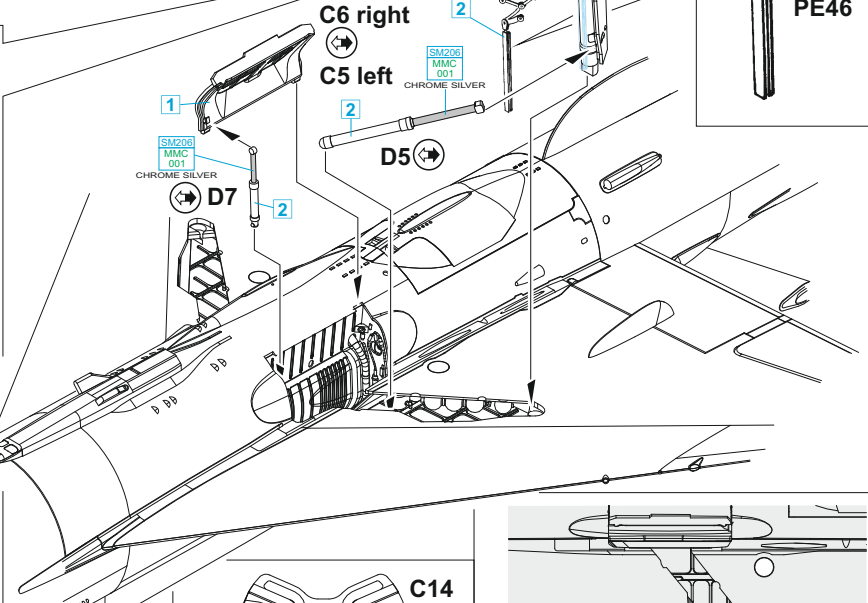

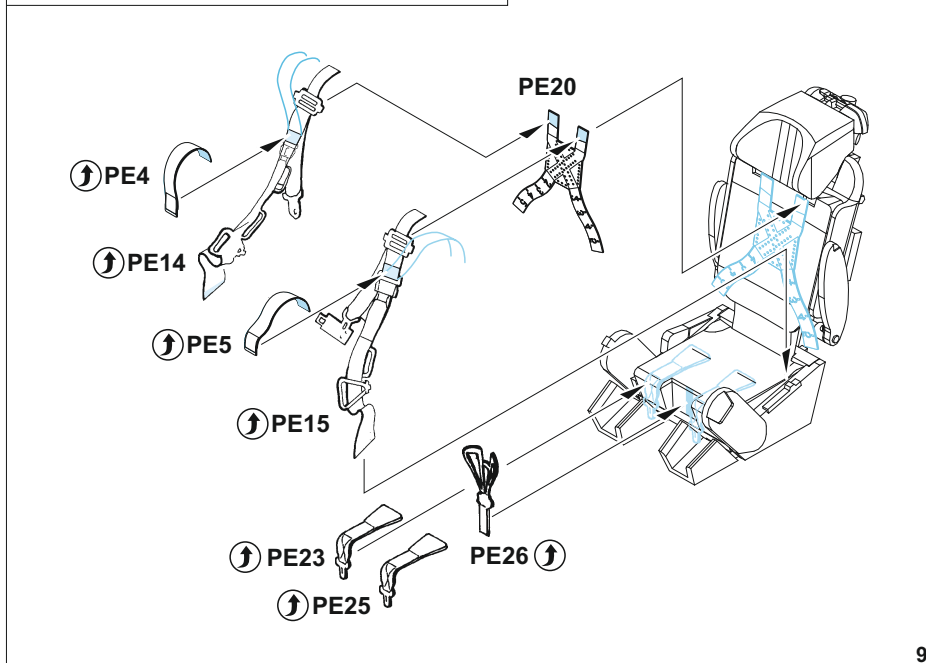
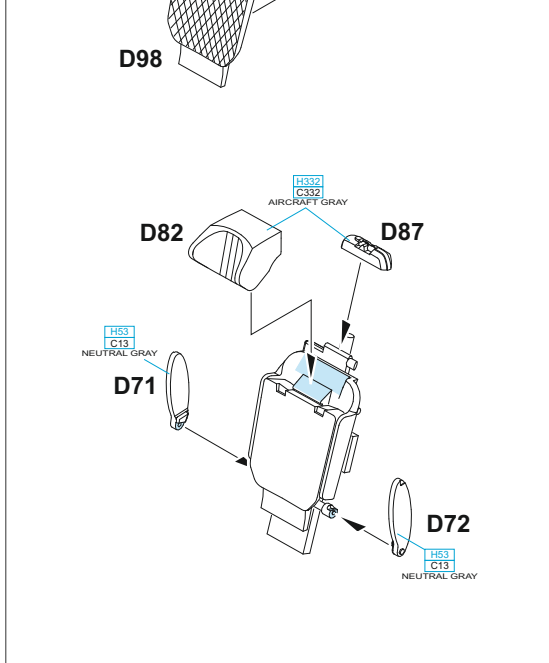
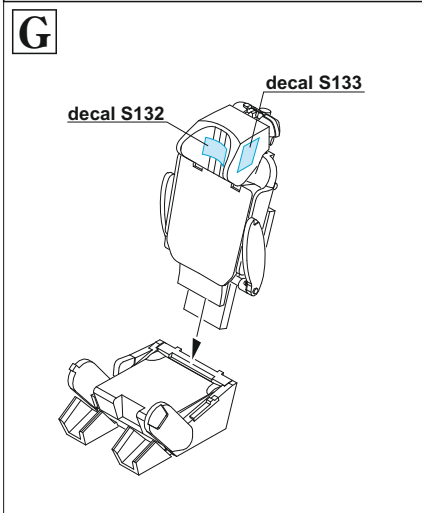
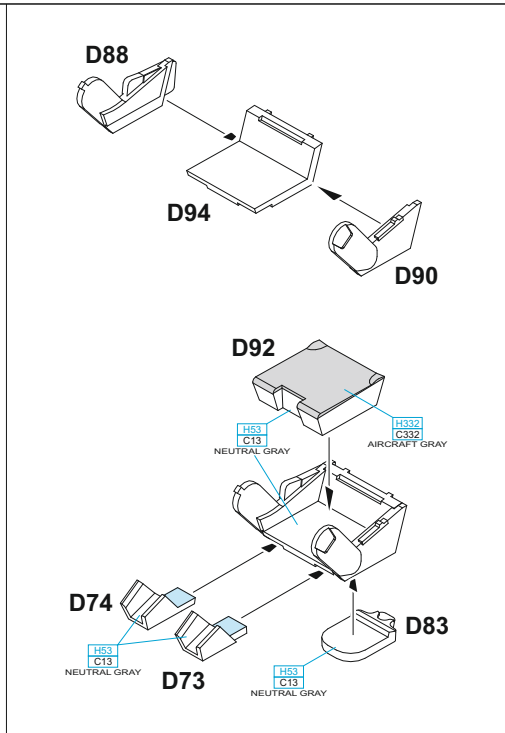
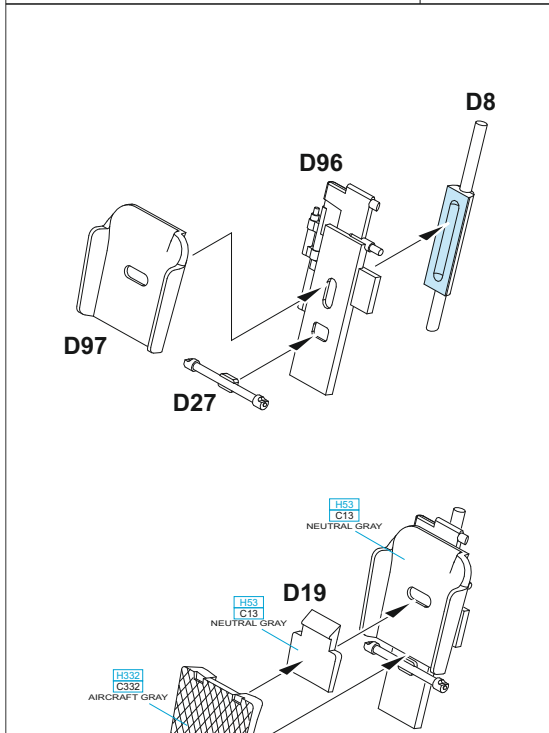
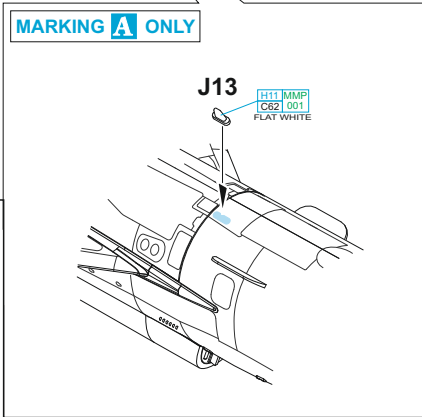
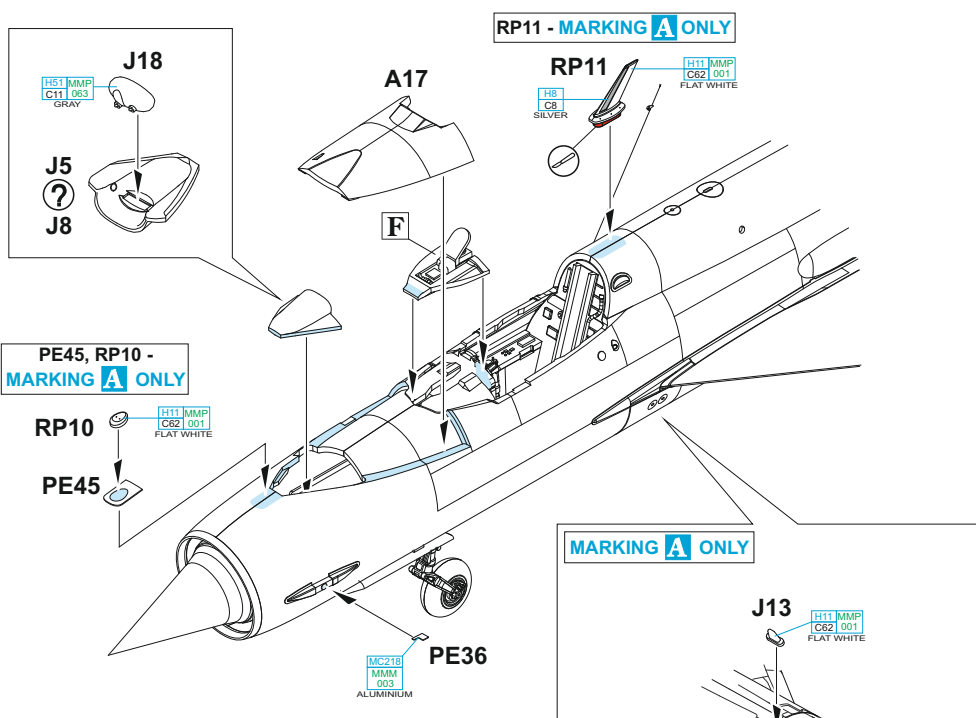
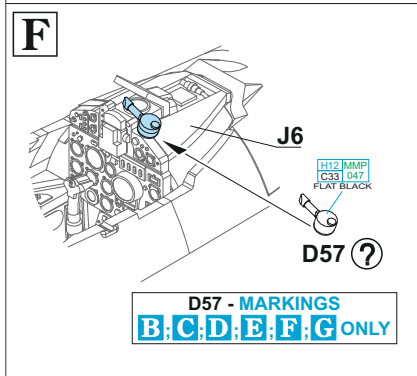
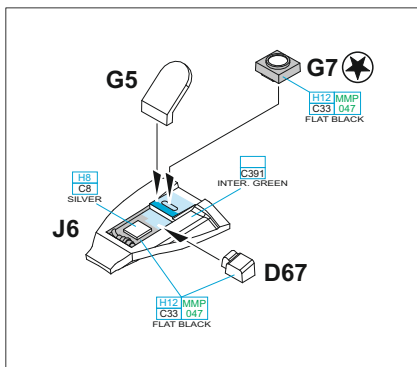

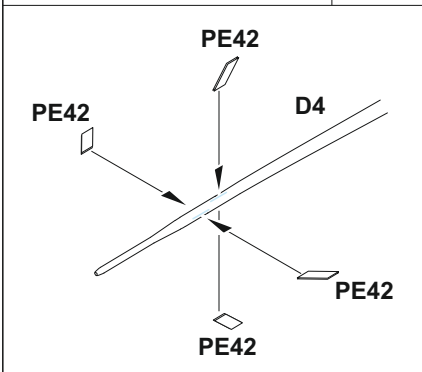
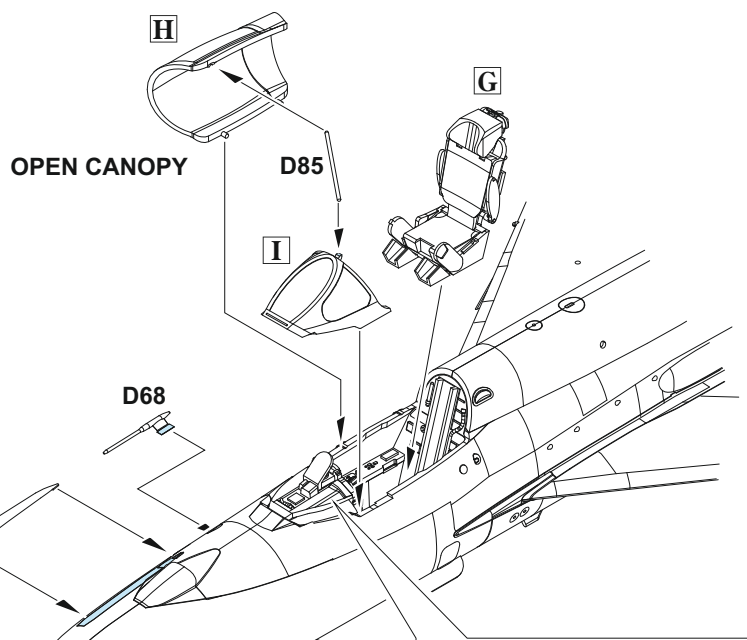
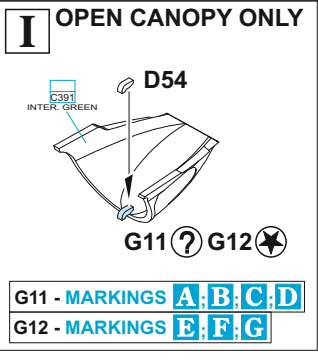
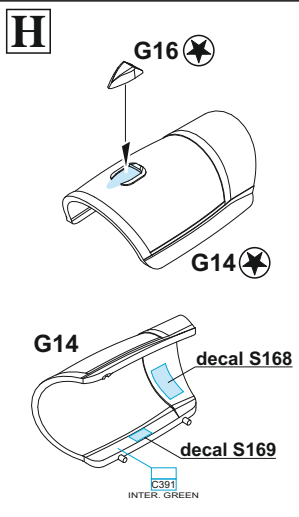

CLOSED CANOPY

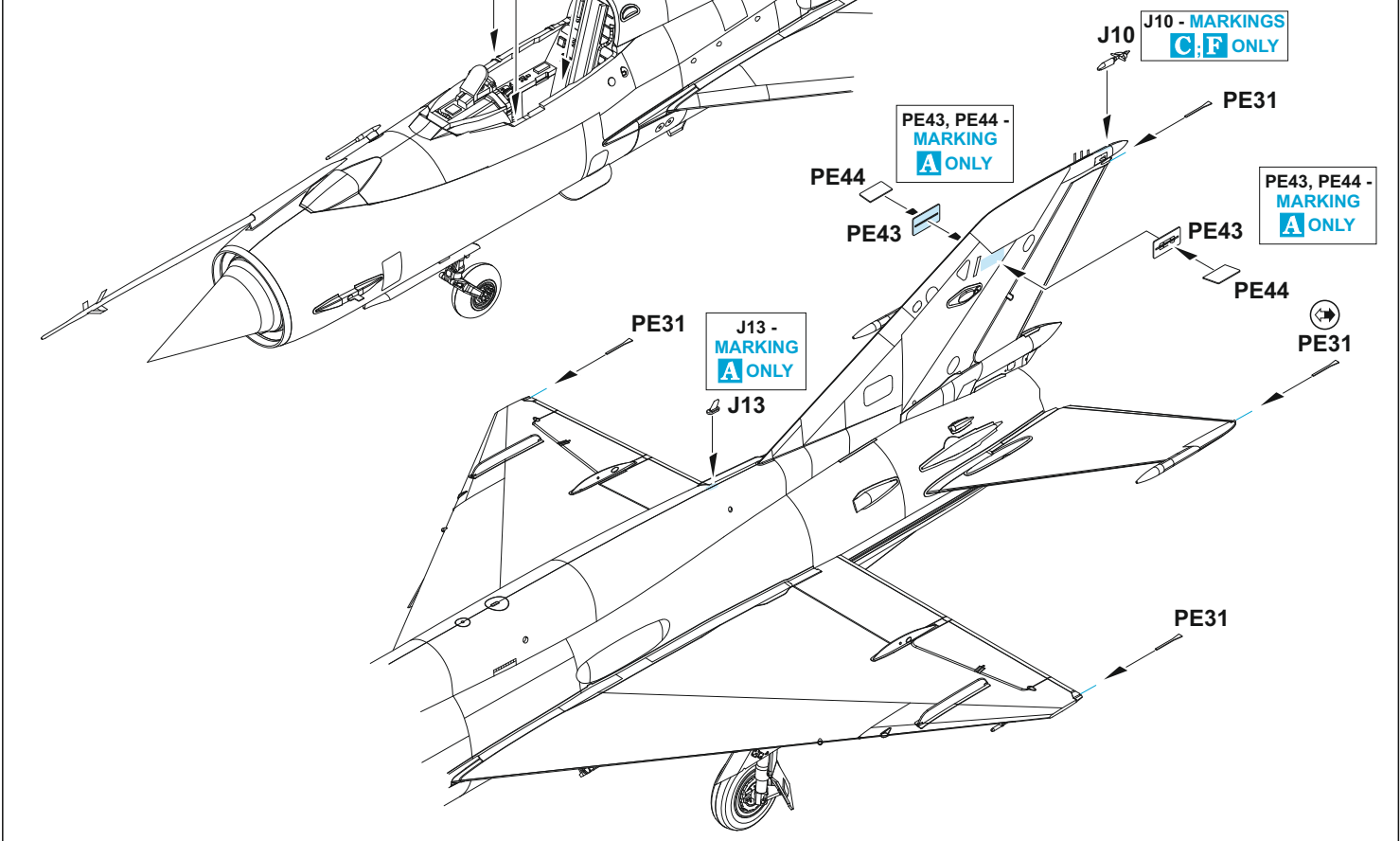
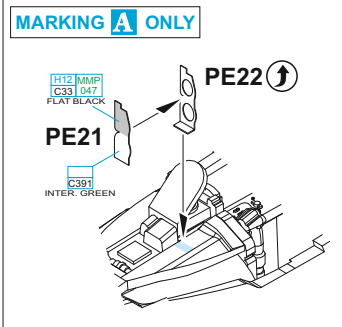
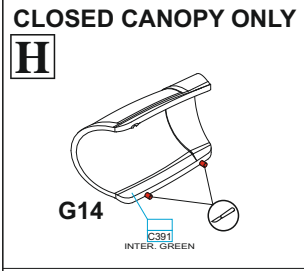

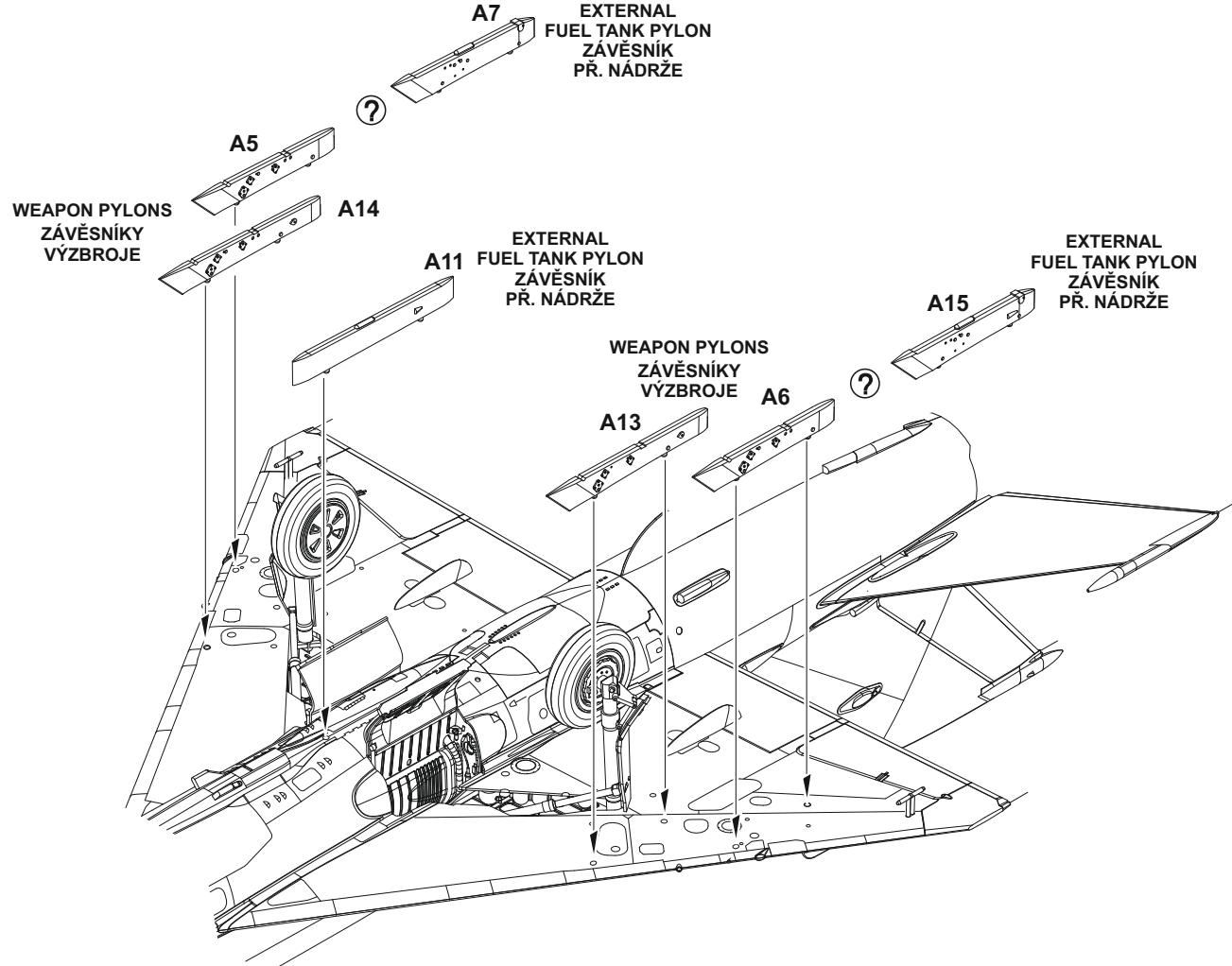
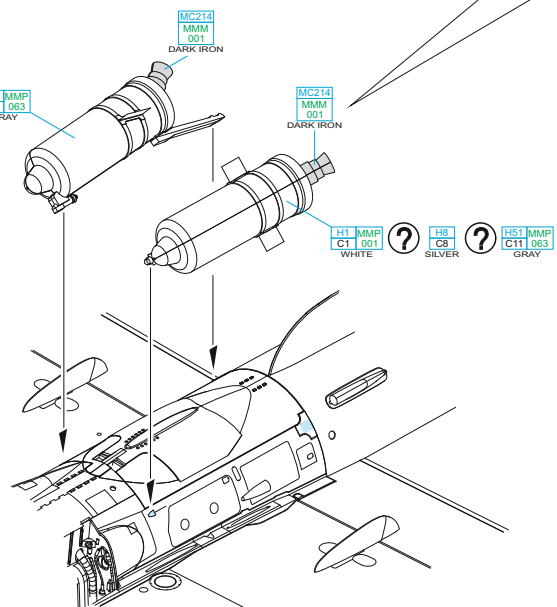
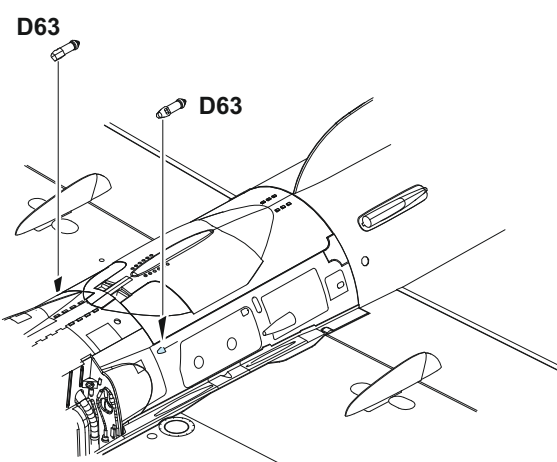
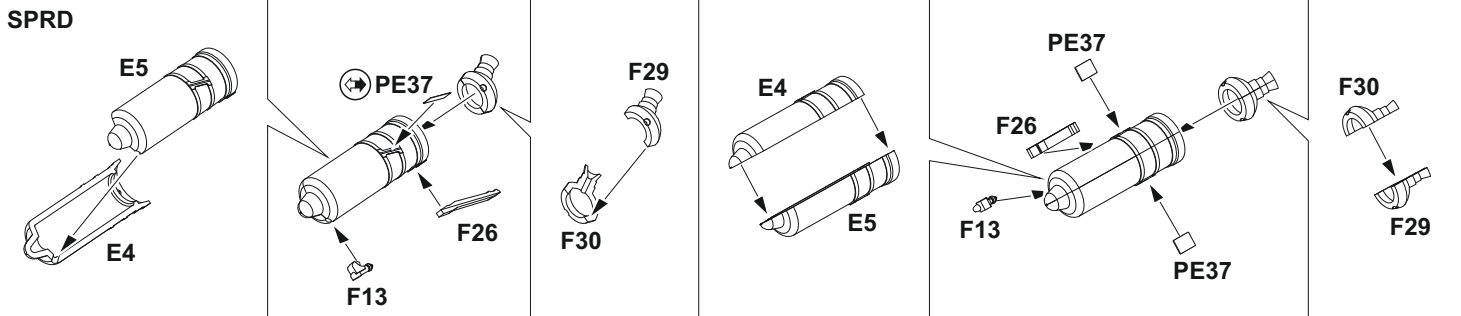

EXTERNAL FUEL TANK 800I

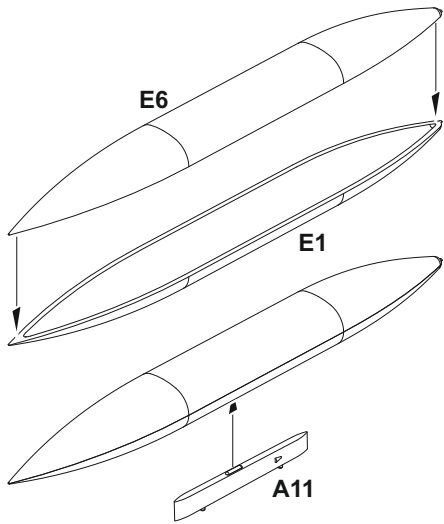

EXTERNAL FUEL TANK 490I
2 pcs.

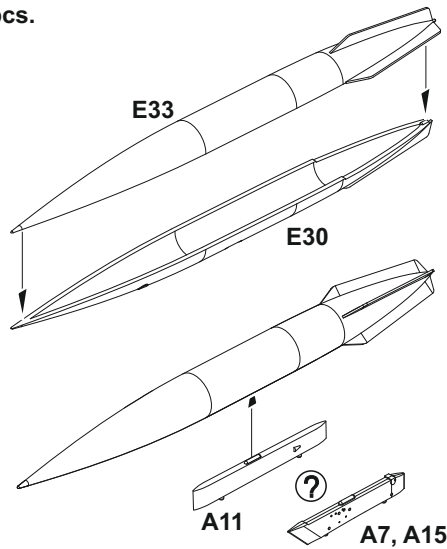

R-13
2 pcs.

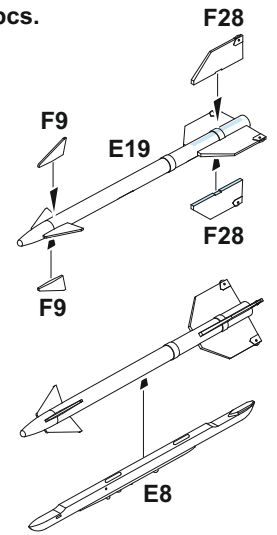

R-60
2 pcs.

4 pcs.

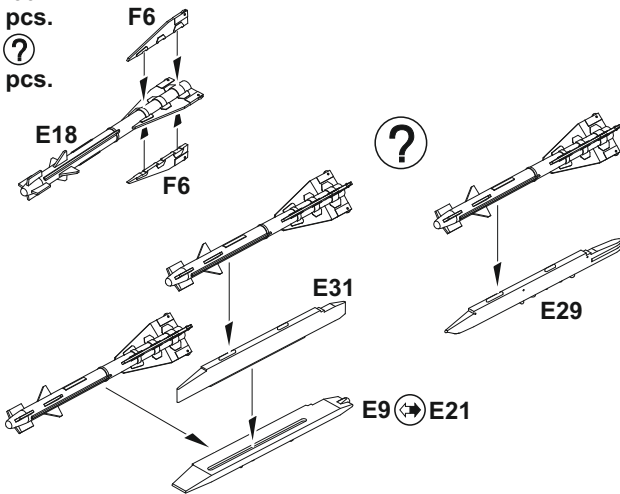

R-3R
2 pcs.

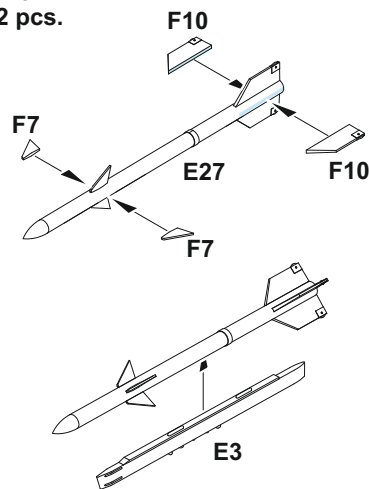

FAB 250 BOMB
2 pcs.

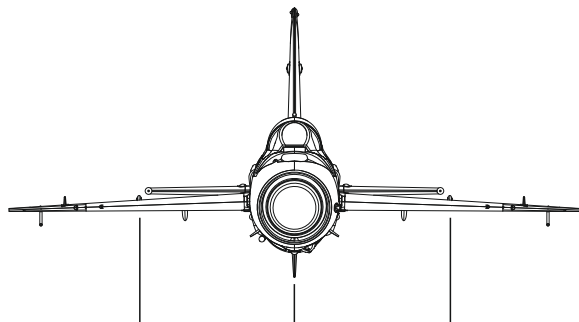
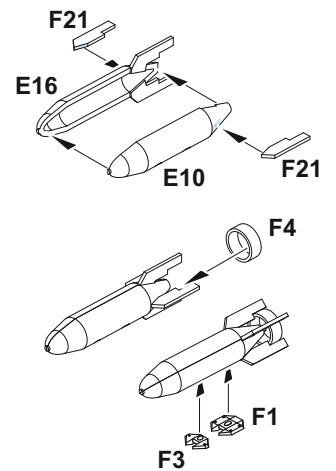

EXTERNAL FUEL TANK 800I
EXTERNAL FUEL TANK 490I
EXTERNAL FUEL TANK 490I

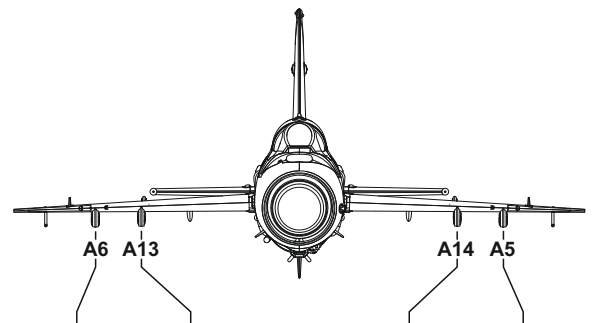
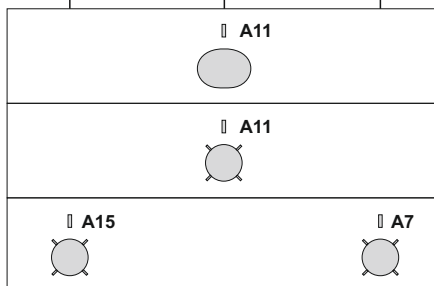

R-60

R-60

R-13

R-3R

FAB 250 BOMB

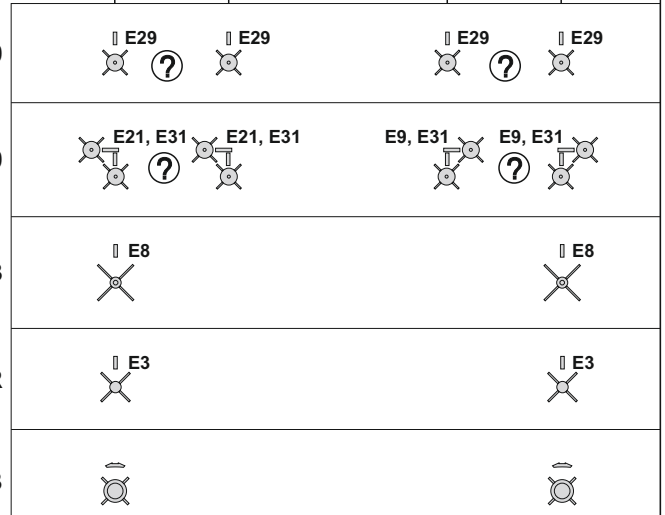

TO CHOOSE WEAPON AND EXTERNAL FUEL TANK OPTION PLEASE FOLLOW YOUR REFERENCE.

PRO VOLBU VÝZBROJE A PŘÍDAVNÝCH NÁDRŽÍ SE DRŽTE DOKUMENTACE KONKRÉTNÍHO STROJE.

FAB 250 BOMB

RP1, 2, 4 → RP1, 3, 4

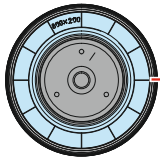

RP6, 8

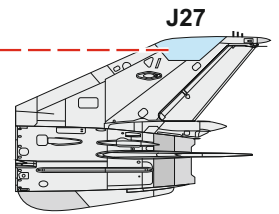
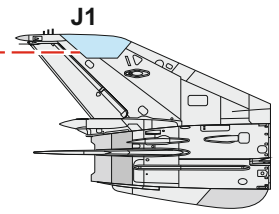
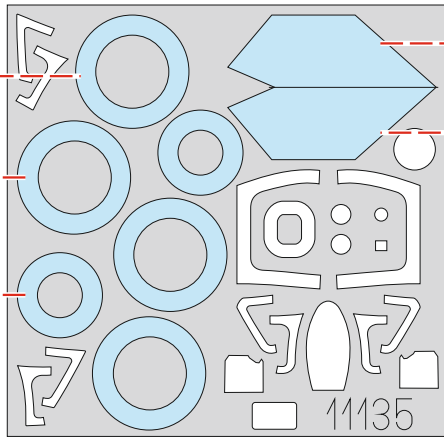

G12

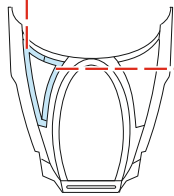

G12

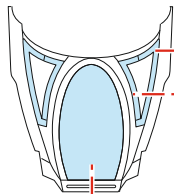

G16

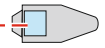

G14

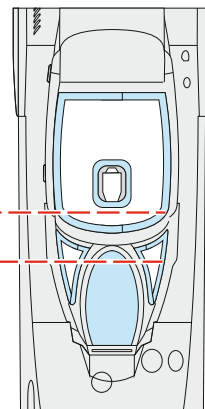

G11

G14

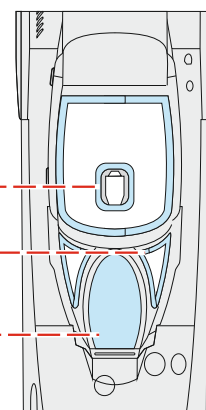

G11

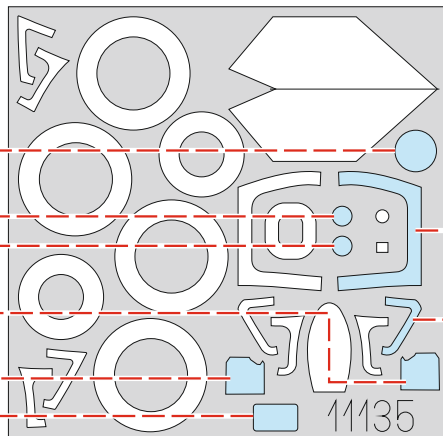
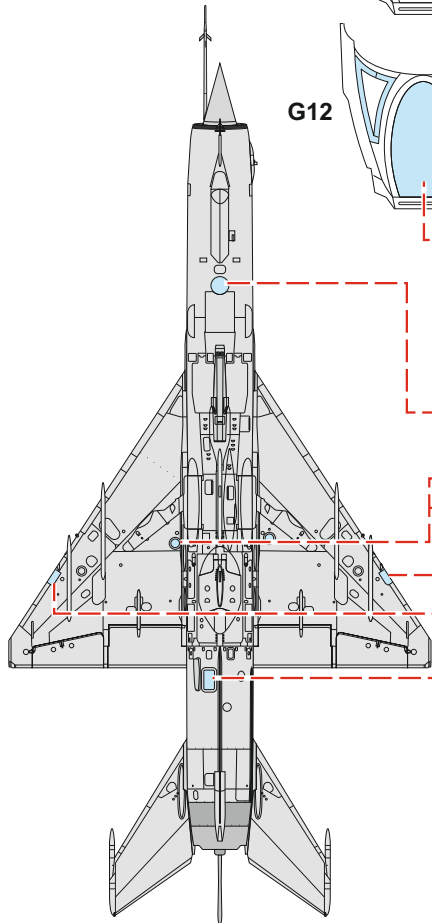

G14

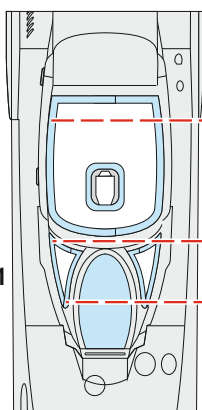

G11

A MiG-21bisD, Eskadrila borbenih aviona, Hrvatsko ratno zrakoplovstvo i protuzračna obrana, Zagreb – Pleso, Croatia, December 2016

The Croatian Air Force purchased forty MiG-21bis fighters and MiG-21UM trainers from Ukraine in 1995. In 2003, eight MiG-21bis aircraft were modernised to bisD standards in Romania. The modernisation program included updating the navigation, communication and IFF equipment. In 2014, another modernisation took place involving seven Croat MiG-21bisD/UMD aircraft, along with a purchase of another five aircraft at a repair facility in Odessa. The modernised aircraft received an all-grey camouflage scheme. Aircraft coded 116 received a stylised '25' on the left side of the fin to commemorate the twenty-fifth anniversary of the Croatian Air Force.

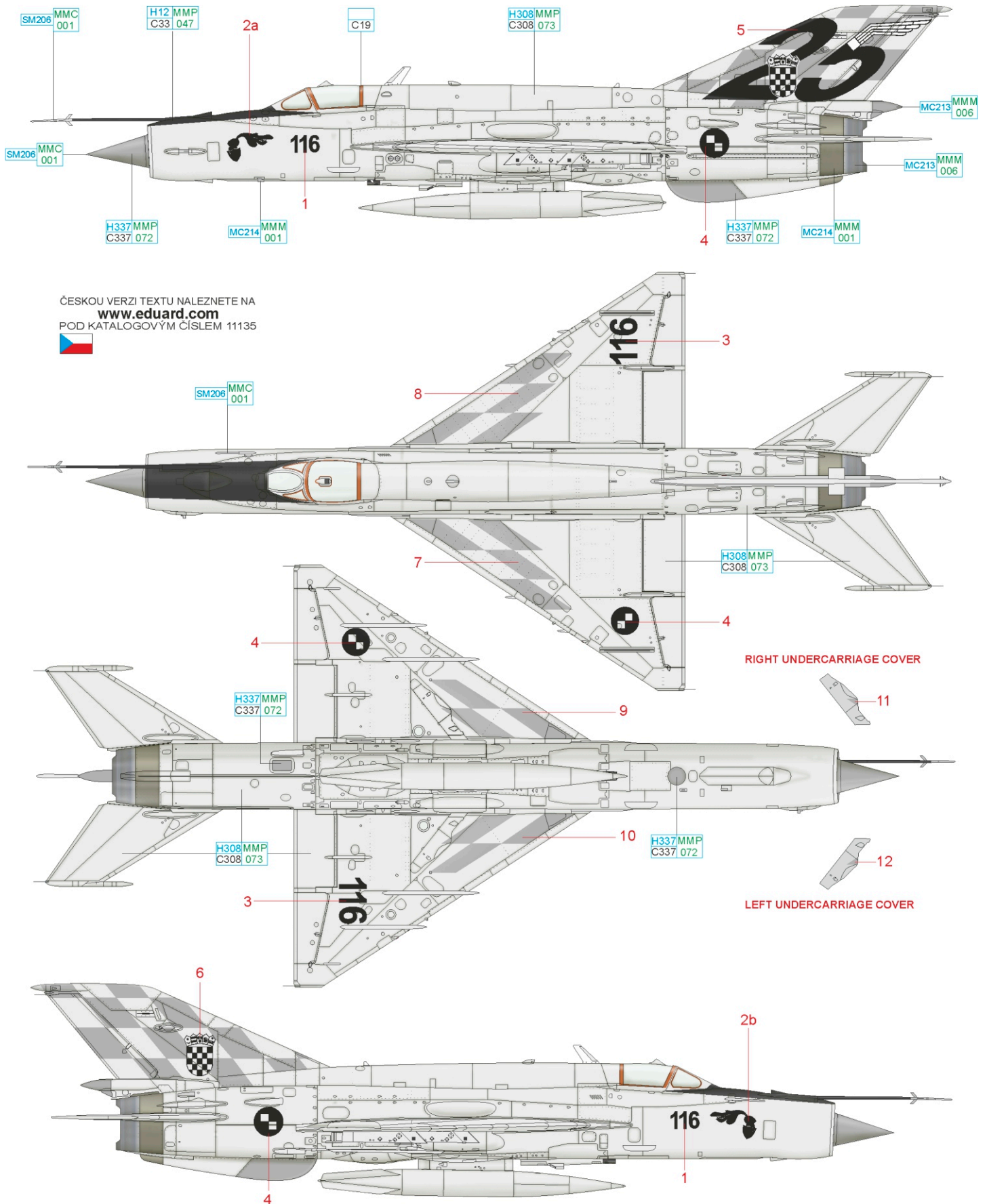

ČESKOU VERZI TEXTU NALEZNETE NA www.eduard.com POD KATALOGOVÝM ČÍSLEM 11135



| | | | | | | | | | | | | | |
|------|-------------------|------|-------------------|-------|-----------------|---------------|---------------|-----------|---------------|-------|---------------|-------------|-----|
| GRAY | H308 MMP C308 073 | GRAY | H337 MMP C337 072 | BLACK | H12 MMP C33 047 | CHROME SILVER | SM206 MMC 001 | DARK IRON | MC214 MMM 001 | STEEL | MC213 MMM 006 | LIGHT BROWN | C19 |
|------|-------------------|------|-------------------|-------|-----------------|---------------|---------------|-----------|---------------|-------|---------------|-------------|-----|



C MiG-21bis, c/n 75061904, 2nd Fighter Squadron, Tazsár Air Force Base, Hungary, 1992

In 1992 a special paint scheme was created by the technicians at Tazsar Air Force Base following on the heels of the "white tail" 1874 aircraft from the previous year's air show circuit. A more distinct and permanent scheme was applied to MiG-21bis (c/n 75061904) of the local Turul squadron. The intention was to provide one fighter for dissimilar air combat training. 'Capeti 1904' was, of course, playing the role of aggressor, to be hunted down by a pair of scrambled fighters. After the show the aggressor role remained and the aircraft was used extensively in the following years. The decal sheet provides two options: one for the actual August 8th/9th, 1992 air show, which included the CAMEL logo, but dropped the tobacco adds for the remainder of the year. In the summer of 1993, 'Capeti' was completely repainted for the Fairford visit, with redesigned markings. 'Capeti 1904' still exists today at the Szolnok museum, but it was repainted five or six times with little resemblance to the original 1992 scheme.

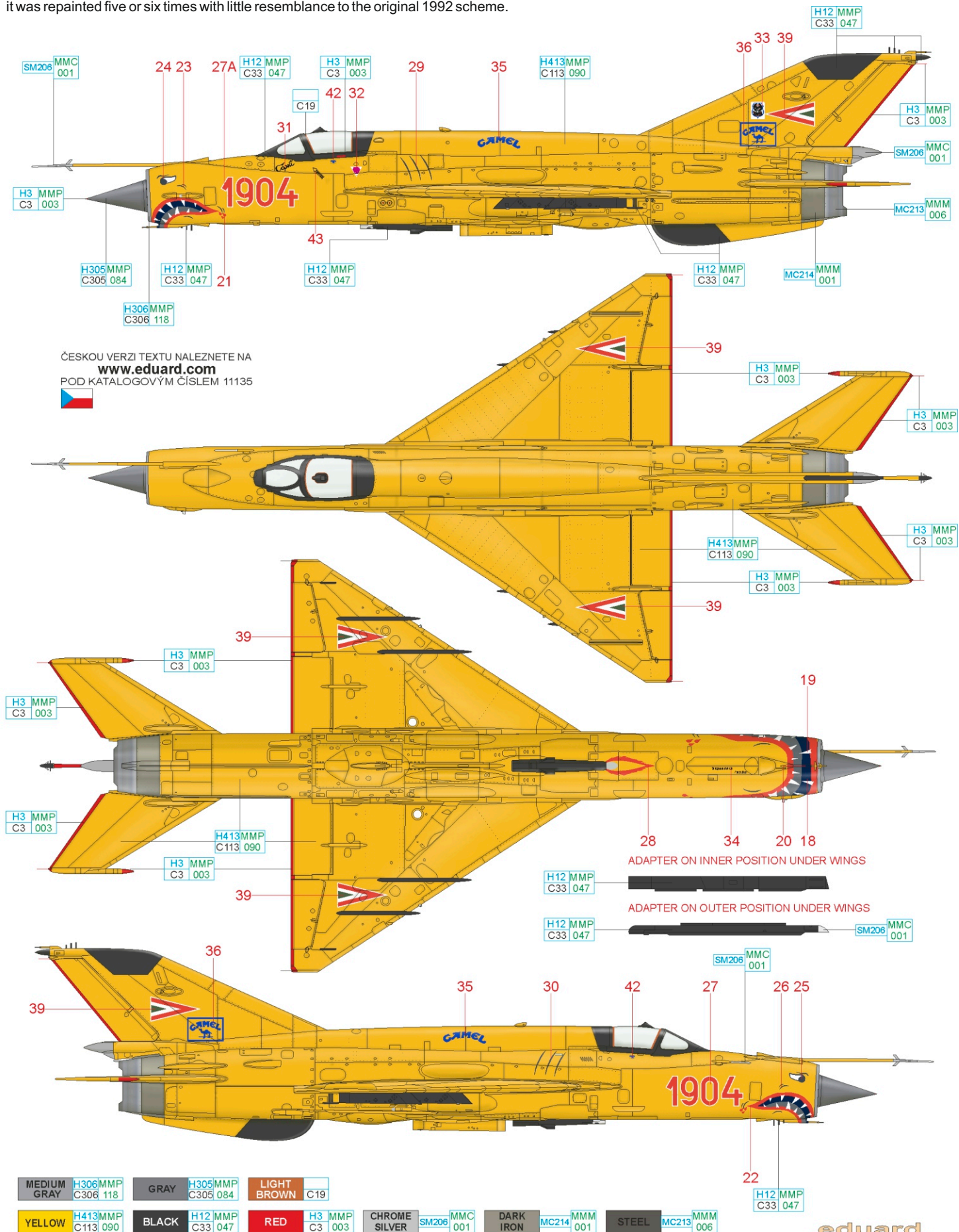

D MiG-21bis, Free Libyan Air Force, Tobruk, Libya, November 2011

The Free Libyan national army, under the leadership of General Khalifa Haftar, occupied several air bases after its formation, some of which yielded air worthy examples of aircraft abandoned by forces loyal to Muammar Gaddafi. One of the first of these was this aircraft, which was subsequently coded '800' and was flown by pilots of the Free Libyan National Army. The Free National Army, under Haftar's leadership, added aircraft to their inventory from other airfields (MiG-21s, MiG-23s, Mirage F-1s and Su-22s) and purchased other aircraft from foreign sources (again, MiG-21s and -23s, along with Mi-24/35 helicopters). The camouflage scheme of this particular aircraft hails from the days of Gaddafi and was first displayed at Lavex in 2007 in Tripoli. The upper and side surfaces of this plane were in sand, brown and green, the lower surfaces were painted a light blue-grey. The markings on the upper surface of the wings remained pre-revolutionary Libyan.

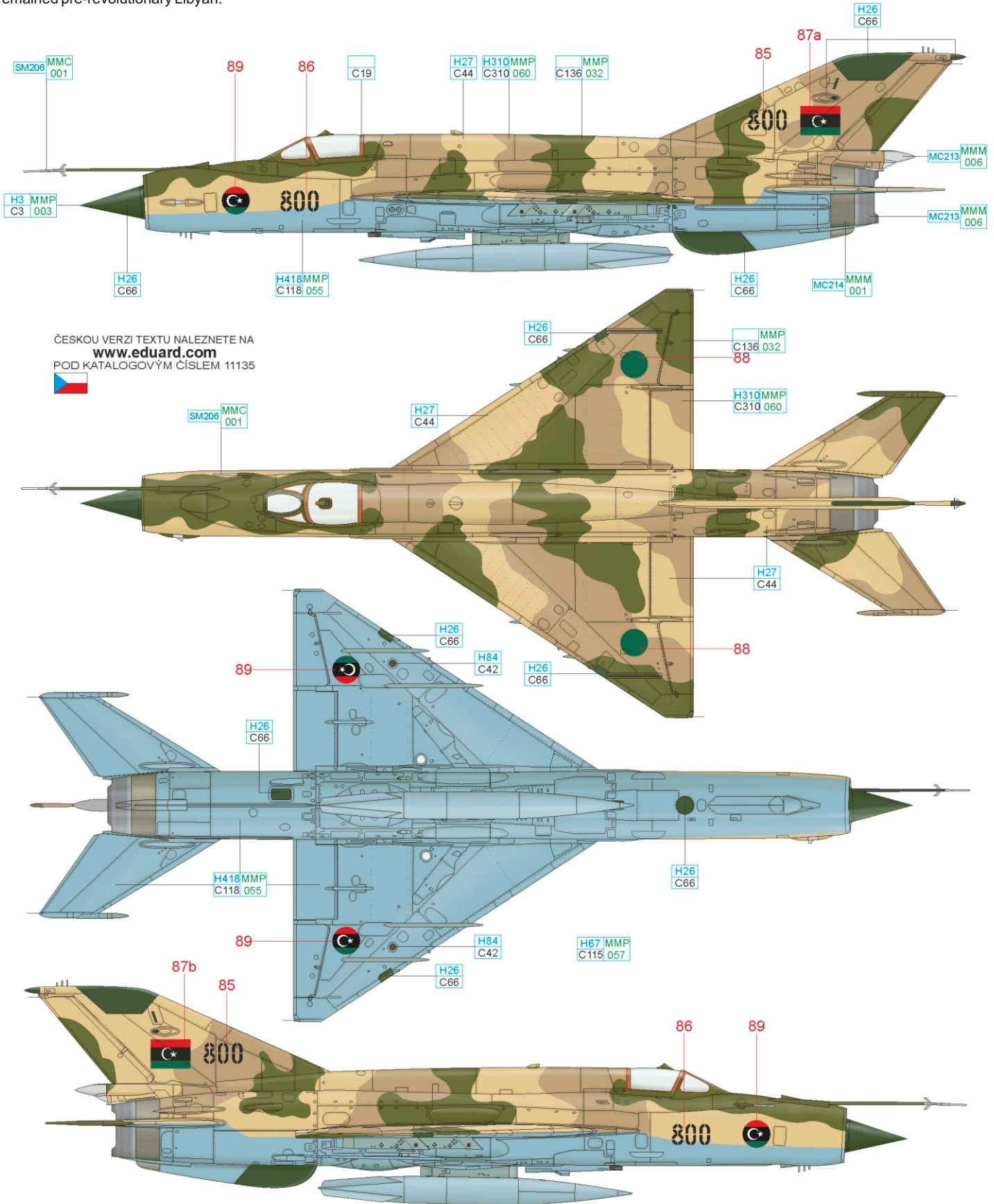

ČESKOU VERZI TEXTU NALEZNETE NA
www.eduard.com
POD KATALOGOVÝM ČÍSLEM 11135



| | | | | | | | | | | | |
|-------------|------------------|----------|---------|--------------|--------------|---------------|---------------|-------------|------------------|------------|------------------|
| LIGHT BROWN | C19 | MAHOGANY | H84 C42 | BRIGHT GREEN | H26 C66 | RED | H3 MMP C3 003 | LIGHT BROWN | H310MMP C310 060 | LIGHT BLUE | H67 MMP C115 057 |
| LIGHT BLUE | H418MMP C118 055 | TAN | H27 C44 | GREEN | MMP C136 032 | CHROME SILVER | SM206 MMC 001 | DARK IRON | MC214 MMM 001 | STEEL | MC213 MMM 006 |

E MiG-21bis, c/n 75080880, 1. Pucki DLMW, Marynarka Wojenna, Gdynia-Babie Doły, Poland, June 2000

The 1st Pucki Dywizjon Lotniczy Marynarki Wojennej was formed on January 1st, 1995, and it was tasked with protecting the Polish shoreline, naval vessels and bases of the Polish Navy, as well as deterring attacks by potential adversaries. The name of the unit comes from the traditional, prewar Morski Dywizjon Lotniczy from Puck. Up to its disbandment on December 31st, 2002, the unit flew the MiG-21bis and UM, as well as W-3, Mi-17 and Mi-2 helicopters. Aircraft coded 0880, serving in its original natural metal scheme, had a sharkmouth added to it, along with the regimental insignia behind the fuselage code and the Squadron A badge on the fin. Ahead of the national insignia on the fin, there is a German 2./MFG 2 marking, with which the Polish unit often flew training exercises.

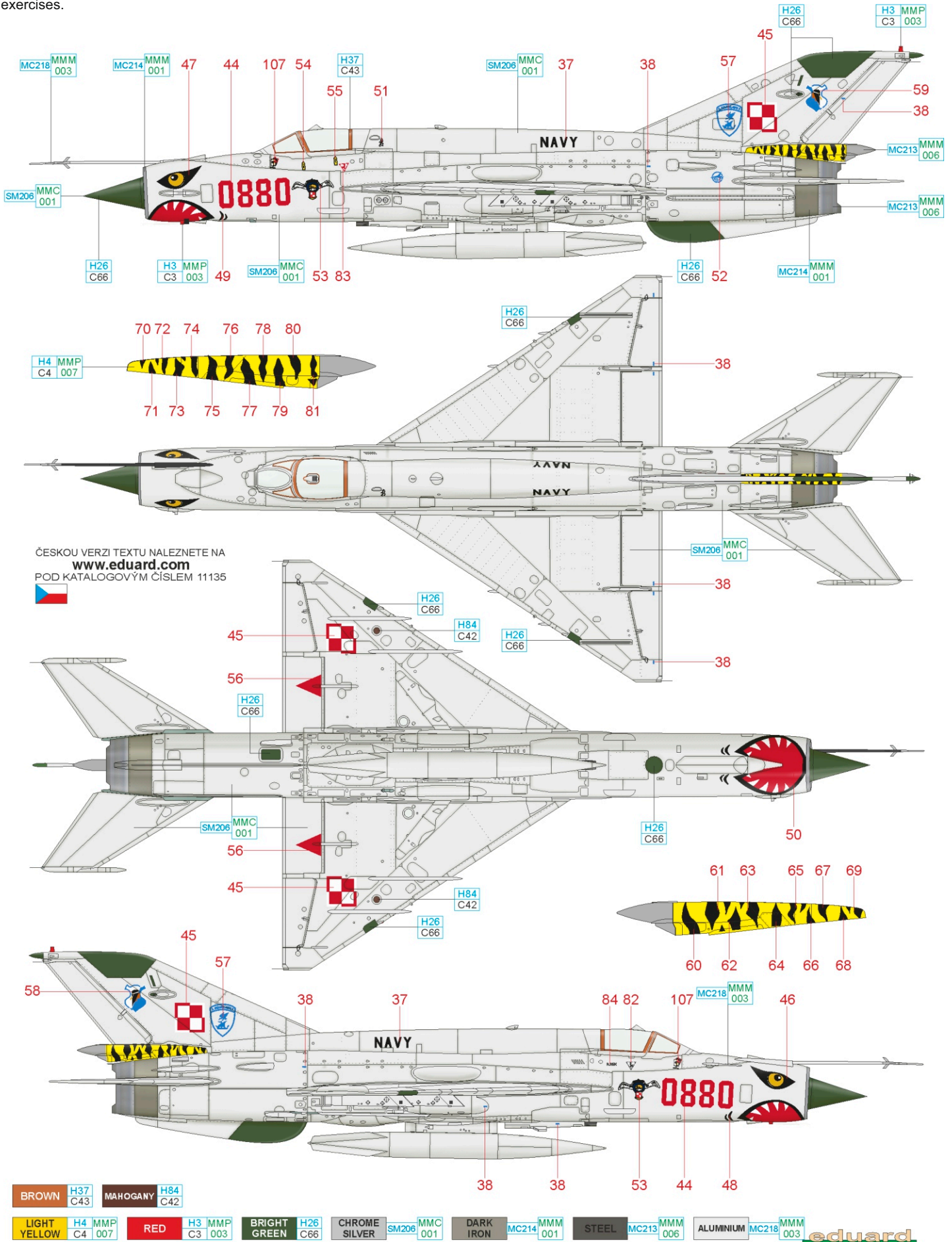

F MiG-21bis, No. 47 Squadron, Iraqi Air Force, Al Hurrya Air Base, Iraq, 90'

The No. 47 Squadron was equipped with the MiG-21bis through the seventies, and over the fall of 1980 scored significant kills against Iranian F-4s and F-5s. During the Iran-Iraq war, Iraqi pilots flying the MiG-21bis fired not only Soviet air-to-air missiles (R-3S, R-13M), but also the French R.550. A typical loadout configuration consisted of two air-to-air rounds and three drop tanks. The aircraft were camouflaged according to period MiG-21 standards developed for export aircraft going to Africa and the Middle East.

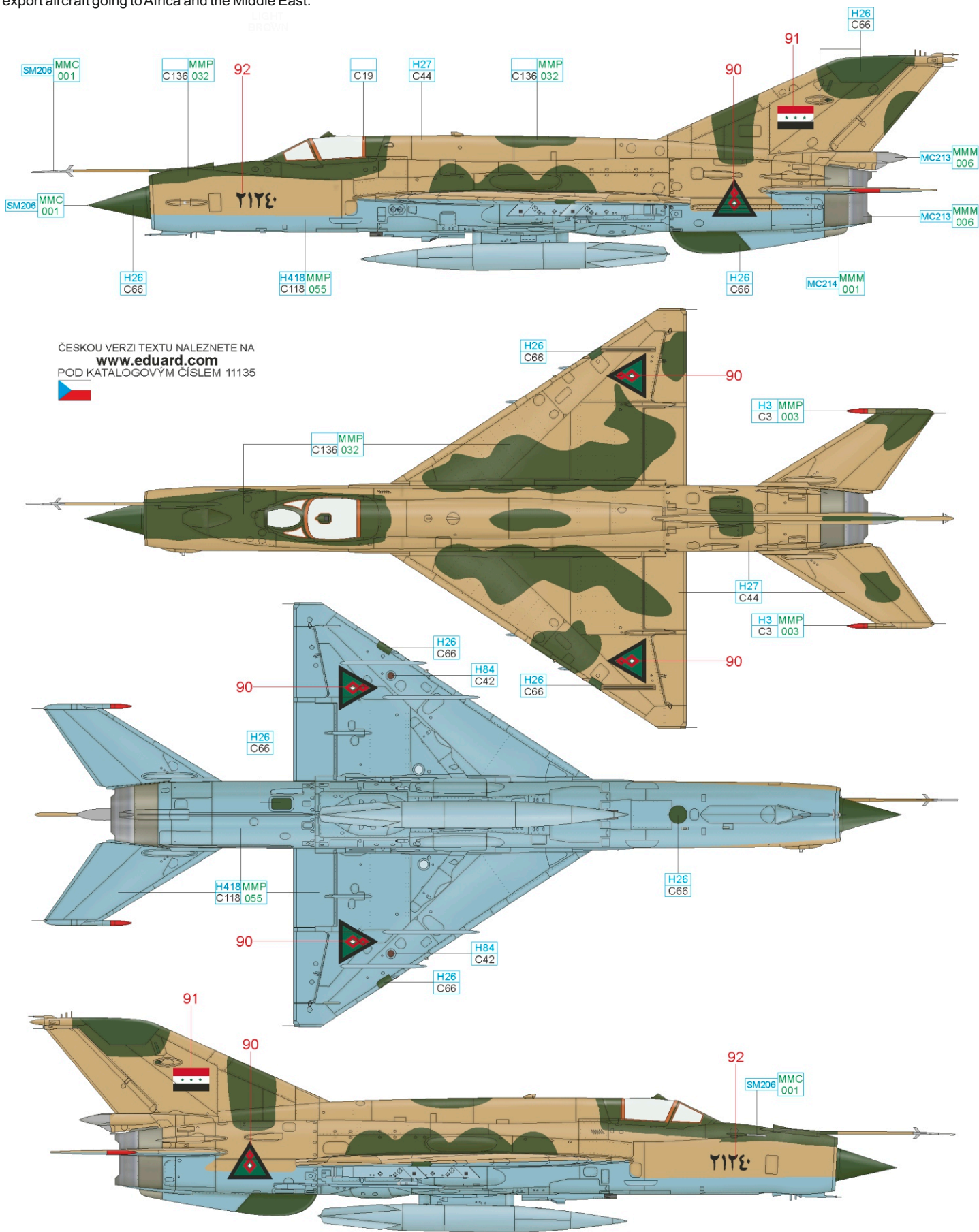

ČESKOU VERZI TEXTU NALEZNETE NA
www.eduard.com
 POD KATALOGOVÝM ČÍSLEM 11135



| | | | | | | | |
|-------------|-------------------|----------|---------|--------------|----------|---------------|---------------|
| LIGHT BROWN | C19 | MAHOGANY | H84 C42 | BRIGHT GREEN | H26 C66 | RED | H3 MMP C3 003 |
| LIGHT BLUE | H418 MMP C118 055 | TAN | H27 C44 | GREEN | C136 032 | CHROME SILVER | SM206 MMC 001 |
| | | | | | | DARK IRON | MC214 MMM 001 |
| | | | | | | STEEL | MC213 MMM 006 |

G MiG-21bis, San Antonio de los Baños, Cuba, 90'

Deliveries of the most modern MiG-21bis aircraft to the Cuban Air Force began in 1981. A total of eighty (with some sources claiming ninety) aircraft served in four regiments. After completing its military career, aircraft coded '637' was used as an instructional airframe at the Instituto Tecnico Militar in Havana. The aircraft was camouflaged in a green and blue-grey scheme, which was used by the Cubans from the beginning of the nineties.

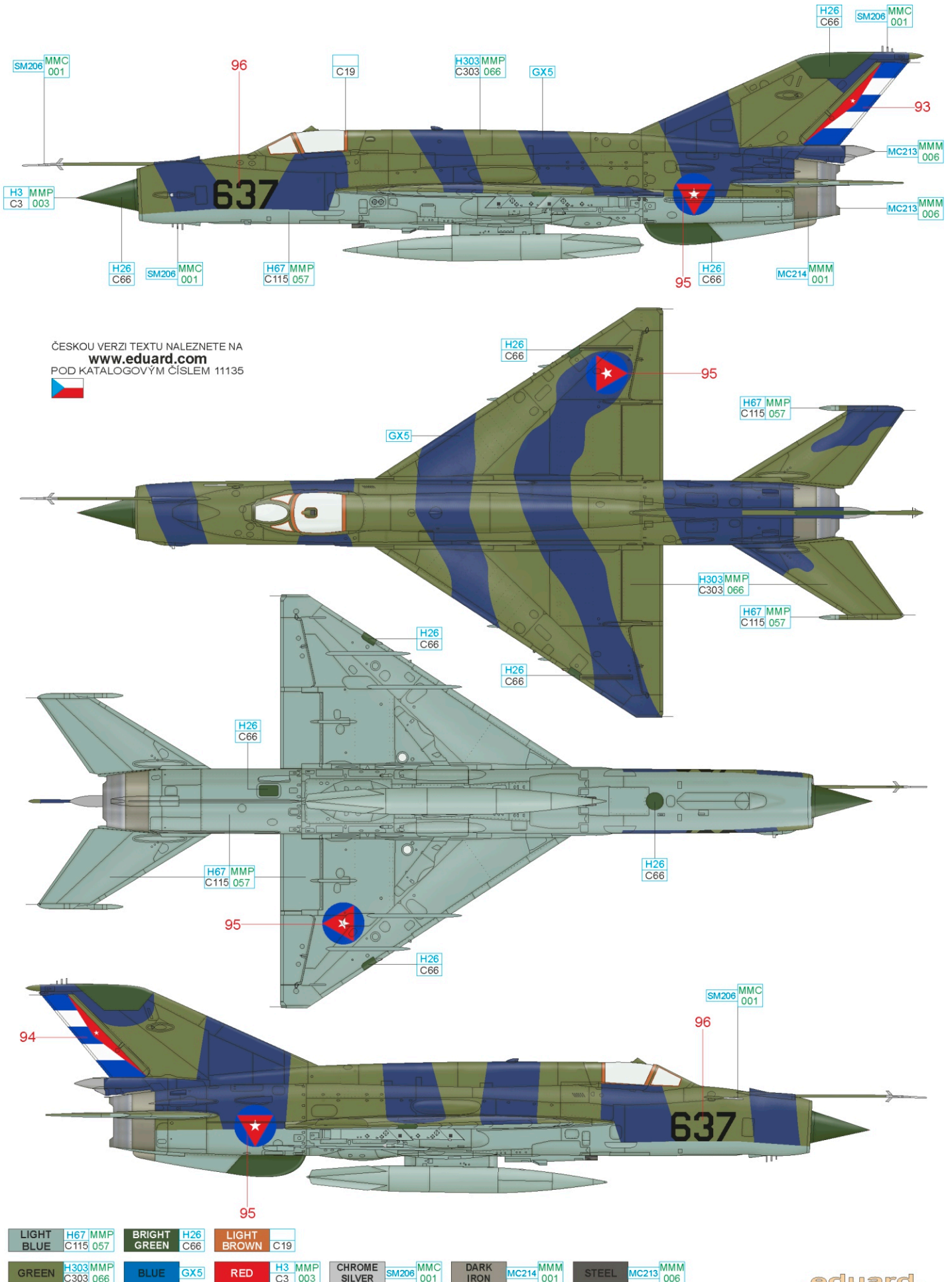

LEVÝ
VNĚJŠÍ PODKŘÍDLOVÝ
PALIVOVÝ
LEFT OUTSIDE
UNDERWING TANK PYLON

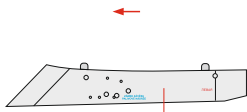

S107

SN - SERIOVÁ ČÍSLA
MALÉ NA DRÁK LETOUNU
STŘEDNÍ NA ZÁVĚSNÍKY
VELKÉ NA RAKETNICE

SN - SERIAL NUMBER
SMALL FOR AIRFRAME
MEDIUM FOR PYLONS
LARGE FOR ROCKET LAUNCHERS



S105



S106

PRÁVÝ
VNĚJŠÍ PALIVOVÝ
PYLON
RIGHT OUTSIDE
UNDERWING TANK PYLON



S108

LEVÝ VNĚJŠÍ PYLON
LEFT OUTSIDE PYLON



S17 ? S33 S109



S110

PRÁVÝ VNĚJŠÍ PYLON
RIGHT OUTSIDE PYLON



S110



S120 S17 ? S33

LEVÝ VNITŘNÍ PYLON
LEFT INSIDE PYLON



S17 ? S33 S111



S112

PRÁVÝ VNITŘNÍ PYLON
RIGHT INSIDE PYLON



S118



S119 S17 ? S33

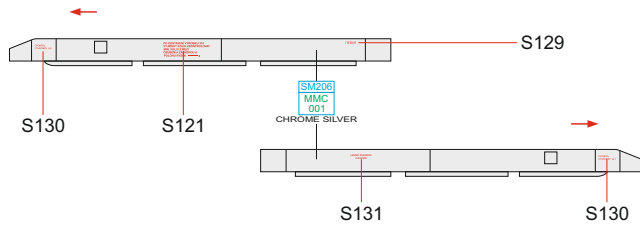

APU-13

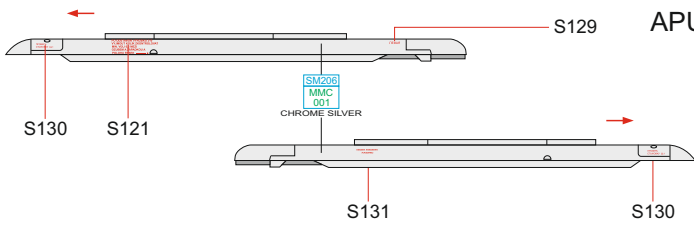
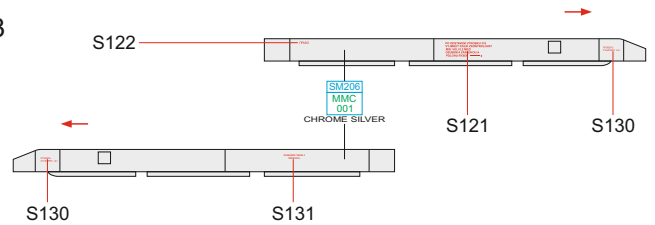

APU-13MT

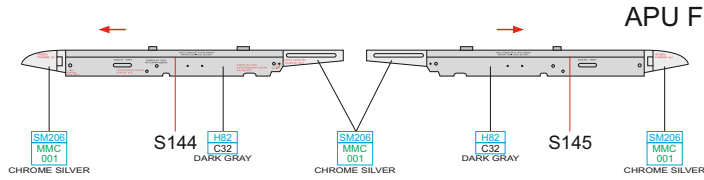
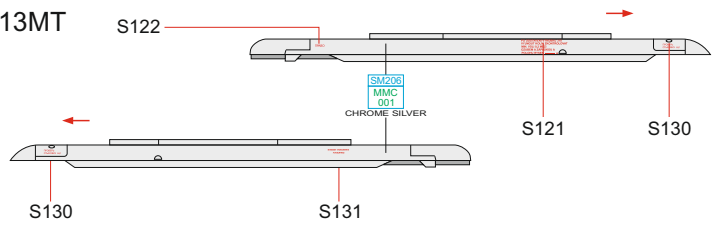

APU FOR R-60

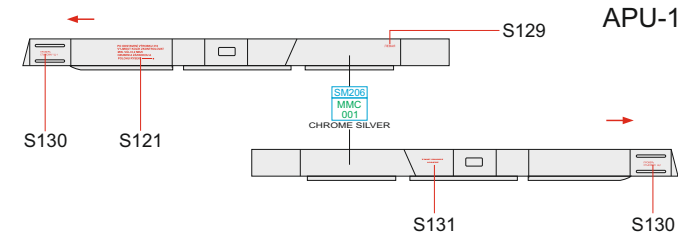
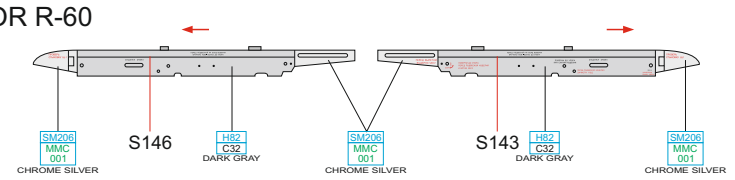

APU-13 FOR R-3R

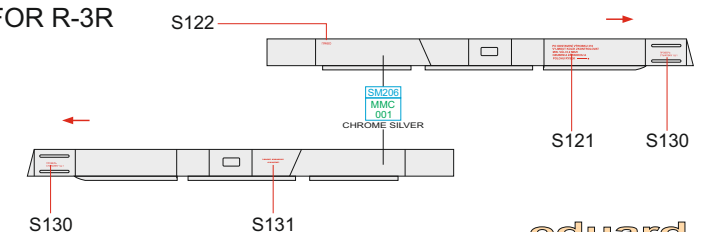

APU-7

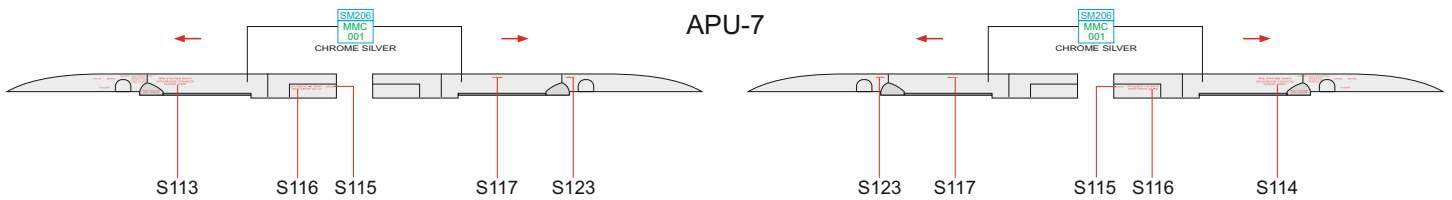

APU 2xR60

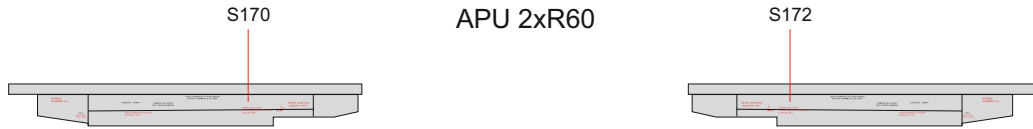

R-3R

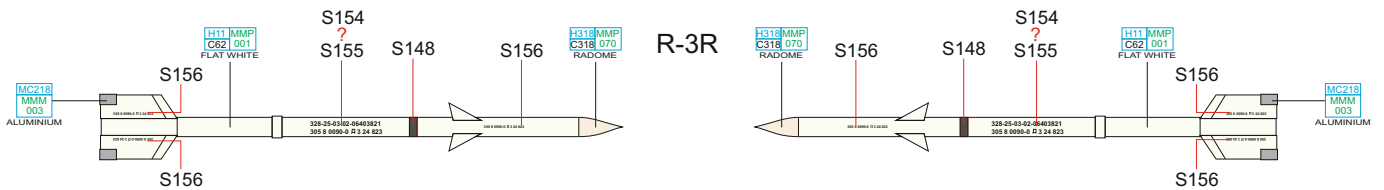

R-13

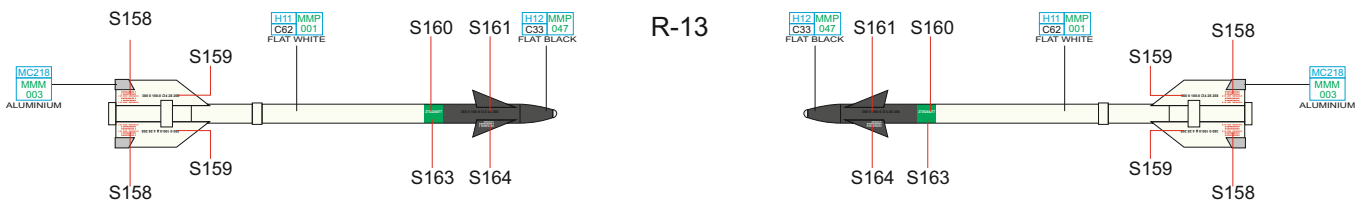

R-60

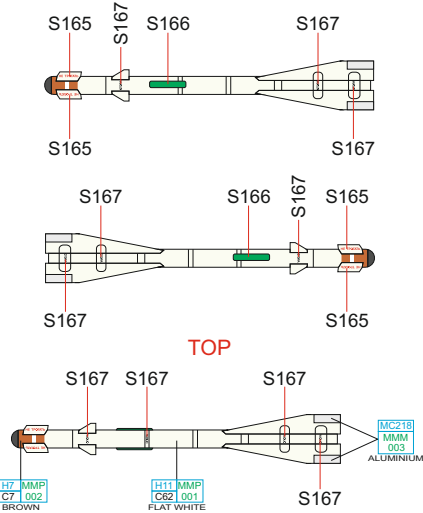

FAB 250

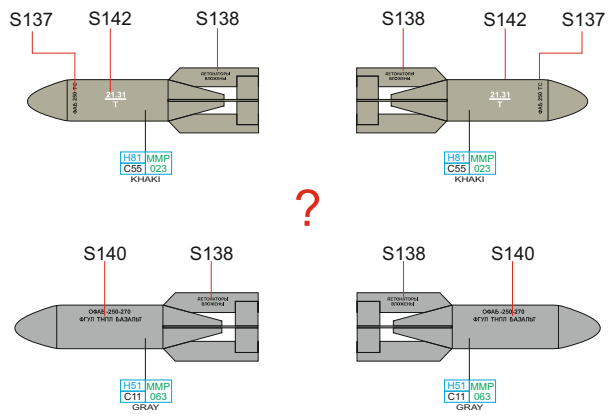

EXTERNAL FUEL TANK 490I



TOP

EXTERNAL FUEL TANK 800I

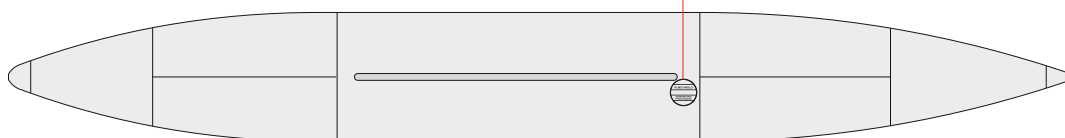

MARKING C ONLY

