

INSTRUCTION SHEET



*Spitfire Story:  
The Few*



**eduard**

**LIMITED EDITION**

**1/48**

# THE SPITFIRE STORY: The Few

## Technical development

The prototype Supermarine Type 300 serial number K5054 took to the skies for the first time on March 5th, 1936 from the Supermarine factory airfield in Eastleigh near Southampton. After a series of changes and improvements, the prototype was transferred for a trial period on May 26th to the Aircraft & Armament Experimental Establishment in Martlesham Heath. On June 6th and 8th during official testing, it reached maximum speed of 561 km/h at altitude of 5100 m. Air Ministry confirmed the renaming of the type to Spitfire on June 10th. On the 3rd of June the Ministry already signed a contract B.527113/36 with company Supermarine for 310 serial Spitfires Mk.I, which acquired serial numbers from K9787 to K9999 and L1000 to L1096. Additional planes were supposed to be made in October 1937 and finished by March 1939, unfortunately both dates weren't upheld due to the capacity deficit in the Supermarine factory and overall difficulties with implementing new technology into their production line. The capacity problem was finally, after the initial pushback from management, resolved by creating an extensive network of subcontractors, who contributed to the 4/5 of the production parts of Spitfires Mk.I. During the implementation of serial manufacturing, on 11th of June 1937, the chief designer of the Spitfire, Reginald Mitchell passed away and was replaced by Joseph Smith. A big obstacle was mainly the construction and manufacturing of the wing, which led to a delay in manufacturing and supply. The fuselages were fully assembled and were waiting for the supply of wings. Supermarine built two new hangars in Eastleigh for the final assembly. First serial Spitfire Mk.I K9787 took flight on 14th of May 1938.

The first Spitfire-reinforced RAF unit was No. 19 Squadron under the command of S/Ldr. Henry Cozens, operating out of RAF Duxford, that was previously flying the Gloster Gauntlet biplanes. Reinforcement started September 11th and the last (sixteenth) Spitfire arrived to the squadron on the 16th of November 1938. The No. 66 Squadron, operating out of Duxford, began its reinforcement in October, and the No. 41 Squadron from RAF Catterick also received its first two Spitfires in the end of the year. Under the influence of the international disputes, the Air Ministry increased their order of Spitfires by 200 airplanes. Another contracts for 200 and 450 planes were submitted on April 20th and the 9th of August 1939, on the 12th of April 1939 the Air Ministry signed a contract with Morris Motors Ltd. for 1000 licensed Spitfires Mk.II, manufactured in a new factory in Castle Bromwich. In the spring and summer of 1939 the production was raising the much needed tempo and had 11 fully equipped Fighter Command squadron before the beginning of the war.

Absolutely crucial, for a successful deployment of the new fighters in the incoming war, was eliminating technical deficiency in the newly produced Spitfires. The first series Spitfires were powered by twelve-cylinder Rolls-Royce Merlin II engine with single-step single-speed compressor with performance of 769kW (1030k). The engine powered a double-bladed wooden propeller Weybridge. Since 78th manufactured plane (K9961, manufactured on the 8th of May 1939) Spitfires Mk.I were equipped with triple-bladed two-positioned steel De Havilland Type 5/20 propeller, which were retro-fitted to the aircraft originally equipped with two-blade propeller. From K9980 (16th of May 1939) the Spitfires Mk.I were powered by new a more reliable engines Merlin III with the same performance, cooled with a mixture of water and glycol (70:30). Merlin II and Merlin III engines used the 87 octane aviation gasoline DTD 230.

Early built Spitfire Mk.I, with two-blade wooden Weybridge propeller, early style antenna mast, early style Pitot tube, with no armor, no gun heating, having flat canopy and iron sights.



A great modification to the Merlin III engine was the option to use 100 octane American fuel, which together with increasing the filling pressure also increased the performance of the engine, especially at lower altitudes. This modification was gradually implemented from spring of 1940, but for regular usage of the 100 octane fuel, the Merlin XII was made, powering the Spitfires Mk.II. Merlins III were made for this fuel directly in the factory since September 1940.

Merlin III allowed assembly of constant speed three-bladed Rotol RMS.8 propeller (Hamilton Standard Hydromatic license), which was used to equip a small amount of Spitfires Mk.I manufactured in the end of 1939. Rotol propellers were mainly used in Spitfires Mk.II from Castle Bromwich and also Hurricanes Mk.I. The only unit with Spitfires Mk.I fully equipped with Rotol propellers was No. 54 Squadron operating in the winter of 1939/40 from RAF Hornchurch. Because performance of planes with constant speed propeller were outperforming the ones with two-positioned propeller, a modification was made to allow a conversion of De Havilland propellers to be automatically buildable (constant speed). Mentioned modifications were made by an assembly team from De Havilland, the conversion was made between the 24th of June 1940 and August 16th, 1940 in all Spitfires Mk.I and Hurricanes Mk.I, equipped with two-positioned De Havilland 5/20 propellers. Later the De Havilland Type 5/39A constant speed propellers were made mandatory. Merlin engines struggled with oil leak issues and never managed to fixed them completely. There

K5054 Spitfire prototype.



were also problems with the carburetors, which during maneuvers with negative g-force, for example during a hard dive, it would struggle and disrupted the supply of fuel mixture into the engine. The problem was fixed relatively late, only after the Battle of Britain did the mechanics implement a so-called RAE-restrictor, which is a famous alteration of the carburetor, originally invented by Ms. Beatrice Shilling.

A significant change look-wise was the implementation of a bulging canopy. Some claim the manufacturing process began in January 1939 but apparently it made its debut a couple months earlier in a handful of planes, e.g. one Spitfire Mk.I of No. 19 Squadron already used this cover in October 1938.. Problem with this canopy was, that the pilot couldn't open it during flight thus eliminating the option to bail out if it were necessary. For option to stabilize pressure in the cockpit, the mechanics added a small panel to the canopy that pilot could open, to the doors of the cockpit they added a small crowbar and later they implemented a system (made by company Martin Baker) that allowed the cover to completely detach from the plane. This modification was implemented to the battle participating machines during the Battle of Britain. To improve the controls of rear hemisphere of the Spitfire, a rear mirror was implemented, at first this was optional but later became a standard and crucial asset to the plane.

During shooting testing the results showed, that machine guns froze at higher altitudes. The solution was installing a heating system, which brought hot air to the right half of the plane by pipes from the bigger radiator. The modification was introduced into the manufacturing to the 60th plane (K9846) in January 1939 and was added to the already operational planes. Later the air heating was replaced by an electrical one. In times of implementing the Spitfires Mk.I the weaponry was made up of eight Browning machine-guns 7.7mm caliber and thought to be powerful and even fear inducing, as the time went on and the armor around the pilot and fuel tanks was getting stronger, this weaponry became unsatisfactory. But that is not the case of this building kit.

An important modification was the implementation of incendiary ammunition de Wilde. The scope is a crucial part of any weaponry. The first Spitfires were equipped with basic iron sights with a round scope in the cockpit and a mar

Early built Spitfire Mk.I, already with three-blade De Havilland 5/20 two pitch propeller, late style antenna mast and Pitot tube, but still without armor and gun-heating, still equipped with iron sights. Note the tailplane device, protecting the vertical stabiliser in case of use anti-spin parachute.



ker in front of the windshield. That was quickly replaced by a reflective Barr and Stroud GM 2 scope. A photo-machine gun was, after the introduction of Spitfires, added to the weaponry and placed externally to the top part of the right wing in the middle, from K9988 it was mounted to leading edge of wing root. The Pitot tube underwent a modification, the older two-fingers variation was from K9918, flown from March 1939, exchanged for a modern Pitot tube with a T shape.

First Spitfire Mk.I were equipped with shortwave radios TR.9B and TR.9D with antenna located wire antenna between antenna mast and the top of rudder. Since spring 1940 these older radios were replaced by radios TR.1133 operating in VKV, where the antenna was the antenna mast and wire antenna was no longer used. The antenna pillar was originally a high and had a circular cross section, kind of like a broom handle, later it was replaced but a new in much smaller sword shaped column. In September 1940 a new identification tool IFF (Identification Friend or Foe) was added to the Spitfire arsenal, which enabled pilots to identify allies and enemies on their radar display. Nicknamed "pip-squeak" it was made up of two wire antennas, leading from fuselage to the leading edge of the vertical stabilizer tips.

Spitfires entered the service without any passive protection, even though debates about certain components being armored were flying around since 1936, e.g. armored front of the cockpit. Due to problems with development of layered glass this implementation was prolonged, it became a standard with first planes of the N series built in September of 1939. In reality a lot of Spitfires didn't have them in the spring of next year and some of them didn't receive this upgrade until that summer. A completely armored Spitfire Mk.I cockpit was implemented under the modification no.247 on the 6th of June 1940 with the exception of an armor plate behind the seat, a 6mm plate on the engine, a metal sheet covering the cooling liquid tank from the front, and finally with the modification no.315 from the 20th of November 1940 an armor sheet behind the head of the pilot was implemented.

A crucial component of the passive protection was the armor upgrades made to the fuel tanks. Spitfire had two fuselage fuel tanks, the one on the bottom could hold up to 168 liters (37 gallons) and the one on the top could hold 218 liters (48 gallons), both were located behind the engine and in front of the cockpit. As always, there wasn't any protection in the beginning. The first protective measure installed was a stronger, three-millimeter sheet, that protected the outside of the hulls fuel tank. Since April 1940 the bottom fuel tank was protected by a substance called Linatex, which was a sandwich made up of rubber and canvas with thickness between 5 to 15mm. Only by the end of July 1940 with modification no.273 was the fuel tank protected by a self-sealing rubber cover. Unfortunately, in the summer 1940 a lot of Spitfires were operating without any fuel tank protection and the upper tank had no self-sealing cover so when enemy pilots hit the tank it would lead to a fire inside the plane which left the pilot with heavy burns.

Small but a very comfortable change for the pilots was the installation of engine powered hydraulic pump landing gear. The original variant with man-operated pimp required 27 pumps with a lever on the right side of the cockpit

which had an unflattering impact on the process of taking off and landing, it led to small injuries such as scratches known as a Spitfire knuckle.

As you can see, the Spitfire Mk.I underwent , since its incorporation into the RAF in fall 1938 until the end of the Battle of Britain in October 1940, a huge technical development, which greatly increased its fighting capacity and showed, that this plane has a reserve needed for further development. Some problems remained unfixed and are out of the historical reach covered by our kit. It was mainly the problem of the wings solidifying, caused by inflation of their armored overlay during high speeds. At the time when Spitfires Mk.I were in action, this problem was well known and a solution already existed in a form of fully steel rudders, but it never saw the light of day. Spitfires Mk.I also never fulfilled the potential of 100 octane fuel. Weaponry with 7.7mm caliber was in the Summer of 1940 satisfactory, but wasn't up to the standards in fall. Spitfires Mk.IB already experimented with double canons 20mm caliber, but this weaponry was popularized later with Mk.II and mainly with Mk.V, which later became the standard.

Our kit includes Spitfire Mk.IA in multiple variations and development stages, from the introduction to the manufacturing line in 1938 until the Battle of Britain in 1940. We believe, that you can pick from our variations of this beautiful aircraft and hope, that this kit will bring you joy and some new knowledge.

Foto courtesy of Simon Erland and CTK



Late production Spitfire Mk.Ia, with full armor including windshield armor, GM2 gun sight, gun-heating (with gun heating firings on the bottom side of the wing), late style antenna mast and Pitot tube, De Havilland 5/20 propeller, rear mirror and voltage regulator behind the headrest.

ATTENTION



UPOZORNĚNÍ



ACHTUNG



ATTENTION



注意



Carefully read instruction sheet before assembling. When you use glue or paint, do not use near open flame and use in well ventilated room. Keep out of reach of small children. Children must not be allowed to suck any part, or pull vinyl bag over the head.



Před započítím stavby si pečlivě prostudujte stavební návod. Při používání barev a lepidel pracujte v dobře větrané místnosti. Lepidla ani barvy nepoužívejte v blízkosti otevřeného ohně. Model není určen malým dětem, mohlo by dojít k požití drobných dílů.

INSTRUCTION SIGNS \* INSTR. SYMBOLS \* INSTRUKTION SINNBILDEN \* SYMBOLES \* 記号の説明

OPTIONAL  
VOLBABEND  
OHNOUTSAND  
BROUSITOPEN HOLE  
VYVRTAT OTVORSYMETRICAL ASSEMBLY  
SYMETRICKÁ MONTÁŽREMOVE  
ODŘÍZNOUTREVERSE SIDE  
OTOČITAPPLY EDUARD MASK  
AND PAINT  
POUŽIT EDUARD MASK  
NABARVIT

PARTS



DÍLY



TEILE



PIÈCES



部品

## PLASTIC PARTS

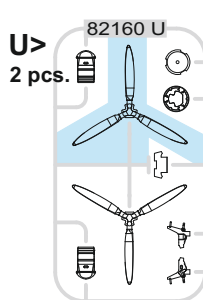
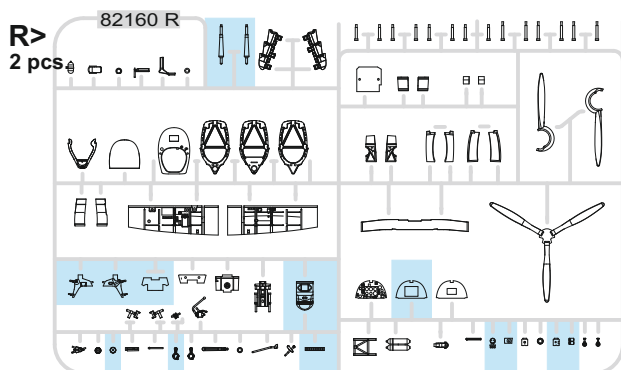
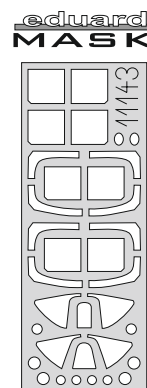
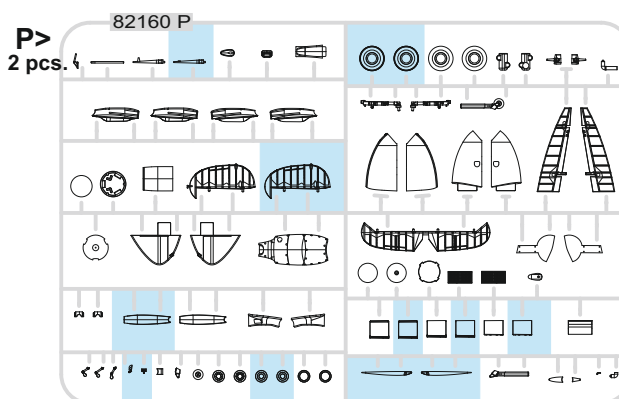
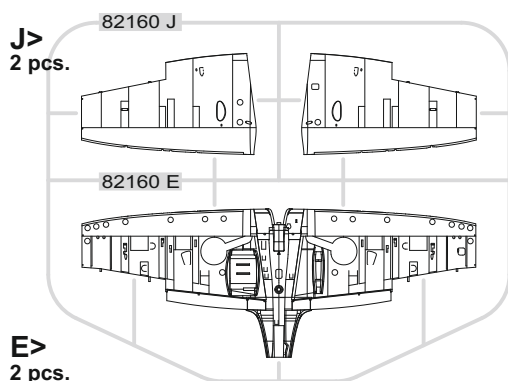
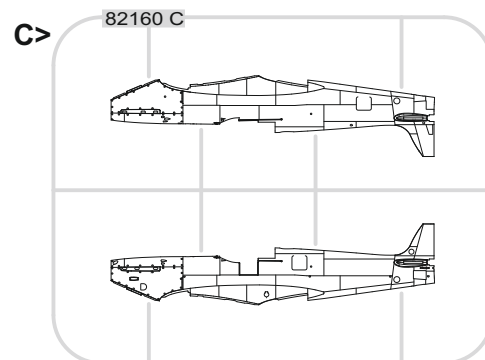
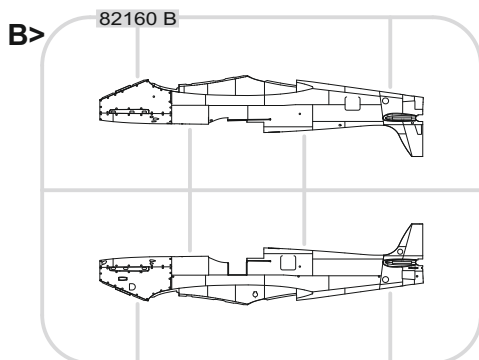
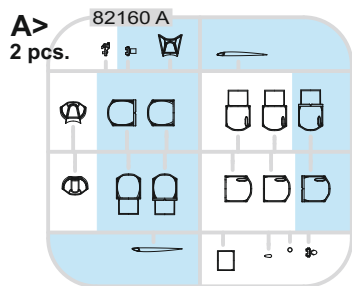

## RP - RESIN PARTS

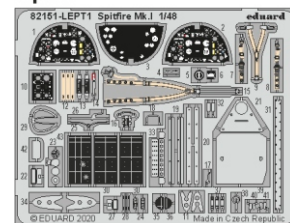
PE - PHOTO ETCHED  
DETAIL PARTS  
2 pcs.

-Parts not for use. -Teile werden nicht verwendet. -Pièces à ne pas utiliser. -Tyto díly nepoužívejte při stavbě. - 使用しない部品

COLOURS



BARVY



FARBEN



PEINTURE



色

GSI Creos (GUNZE)		MISSION MODELS	
AQUEOUS	Mr.COLOR	PAINTS	
H3	C3	MMP-003	RED
H4	C4	MMP-007	YELLOW
H8	C8		SILVER
H11	C62	MMP-001	FLAT WHITE
H12	C33	MMP-047	FLAT BLACK
H51	C11	MMP-063	LIGHT GULL GRAY
H72	C369	MMP-078	DARK EARTH
H74	C368	MMP-080	SKY
H77	C137	MMP-040	TIRE BLACK

GSI Creos (GUNZE)		MISSION MODELS	
AQUEOUS	Mr.COLOR	PAINTS	
H90	C47		CLEAR RED
H94	C138		CLEAR GREEN
H330	C361	MMP-077	DARK GREEN
	C26	MMP-080	DUCK EGG GREEN
	C364	MMP-079	AIRCRAFT GRAY-GREEN
Mr.METAL COLOR		METALLICS	
	MC214	MMM-001	DARK IRON
	MC218	MMM-003	ALUMINIUM

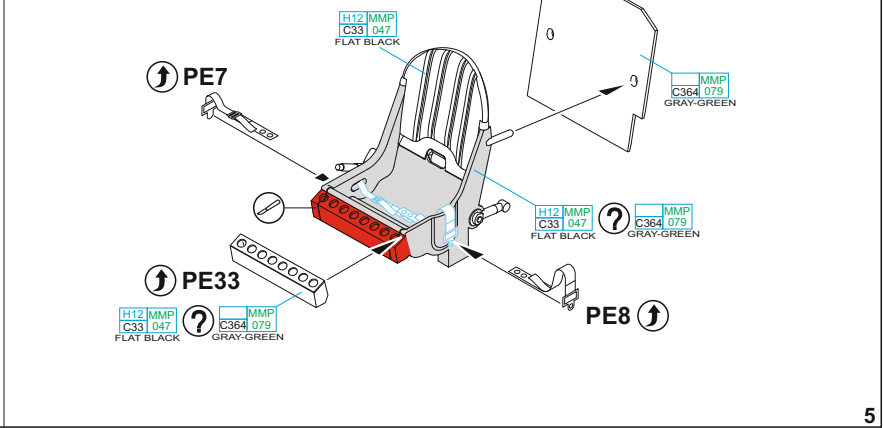
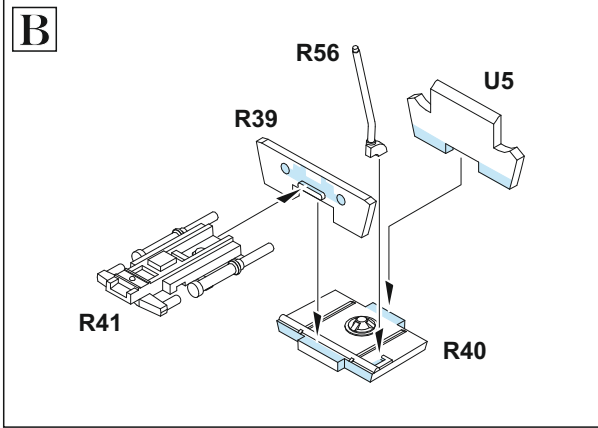
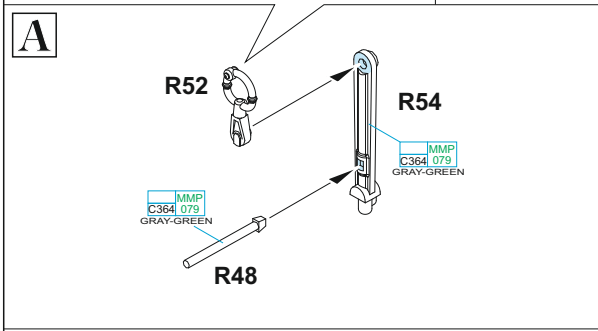
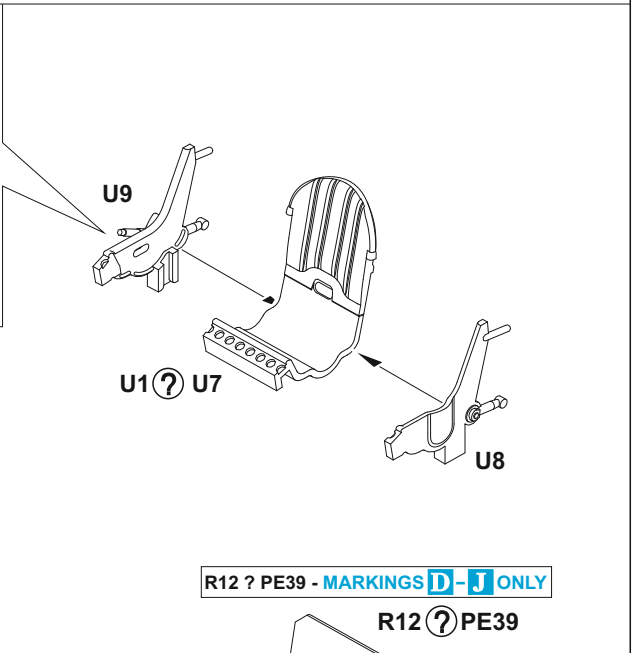
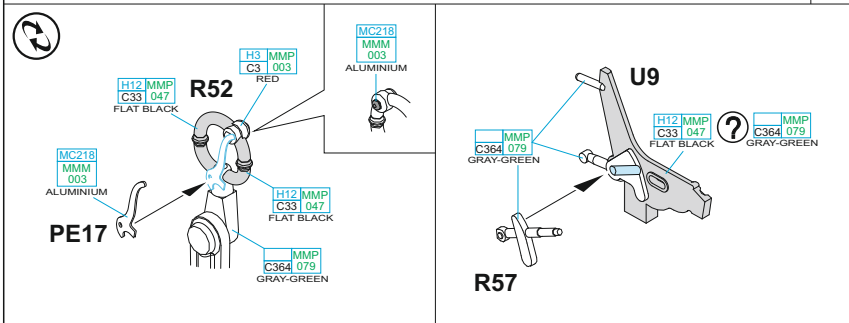
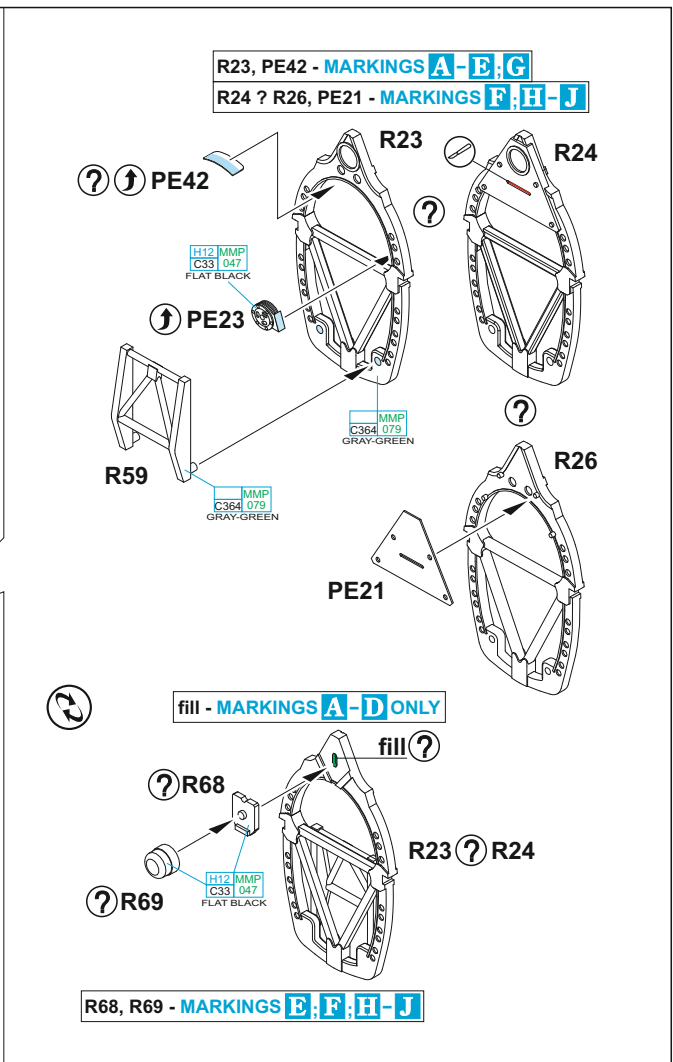
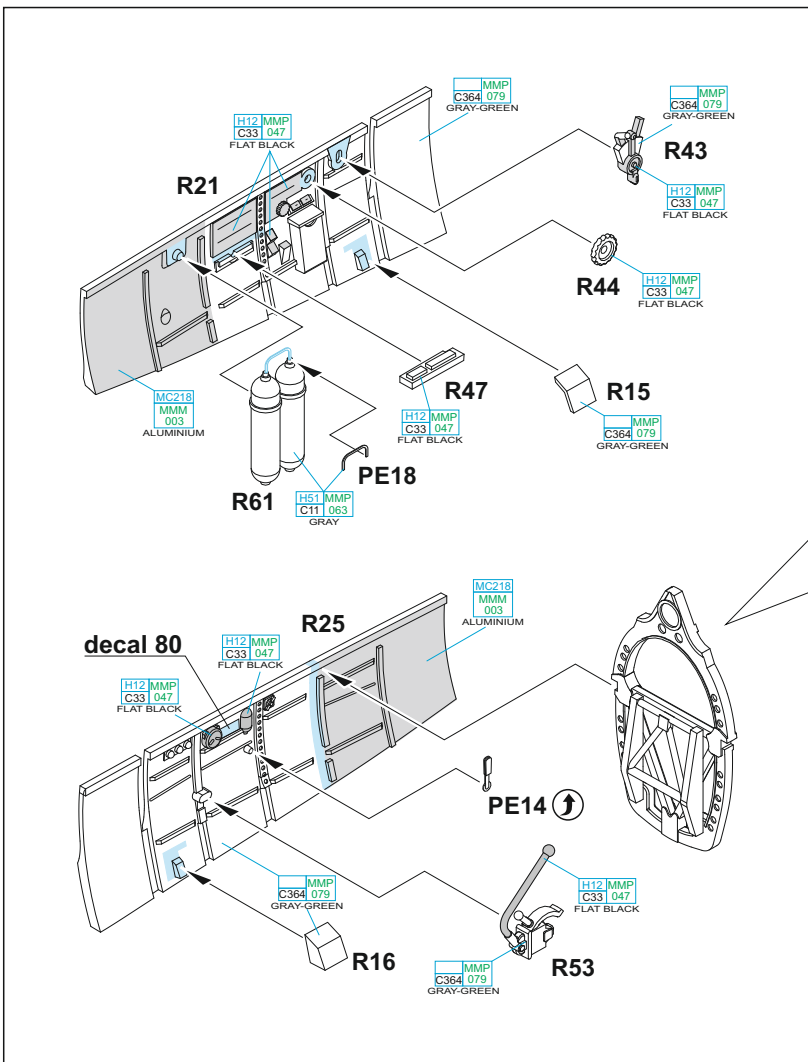

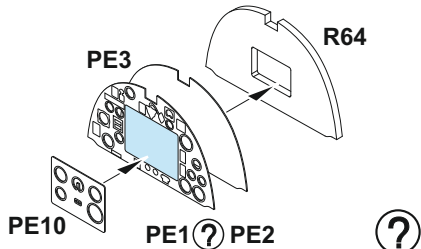
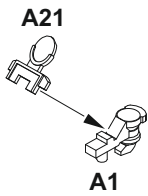
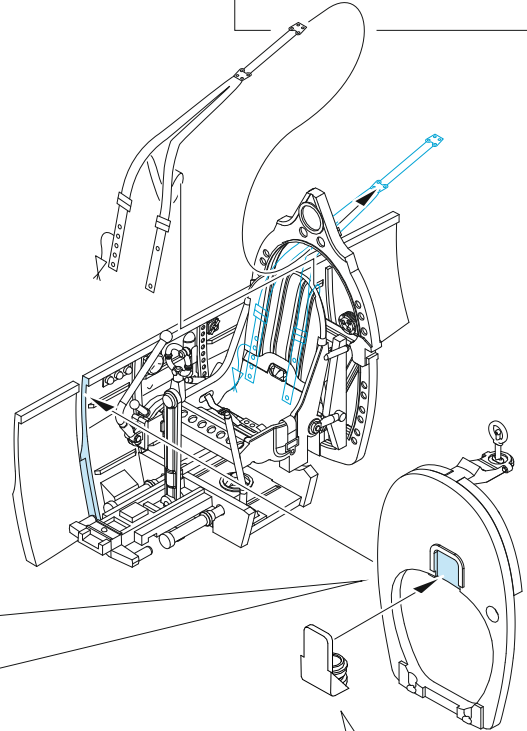
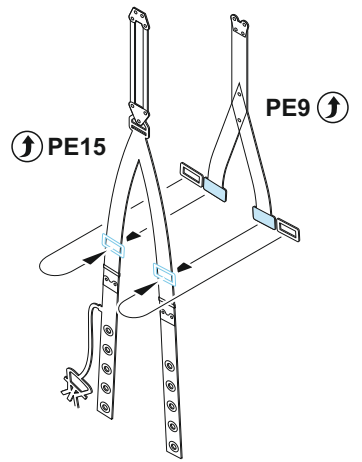
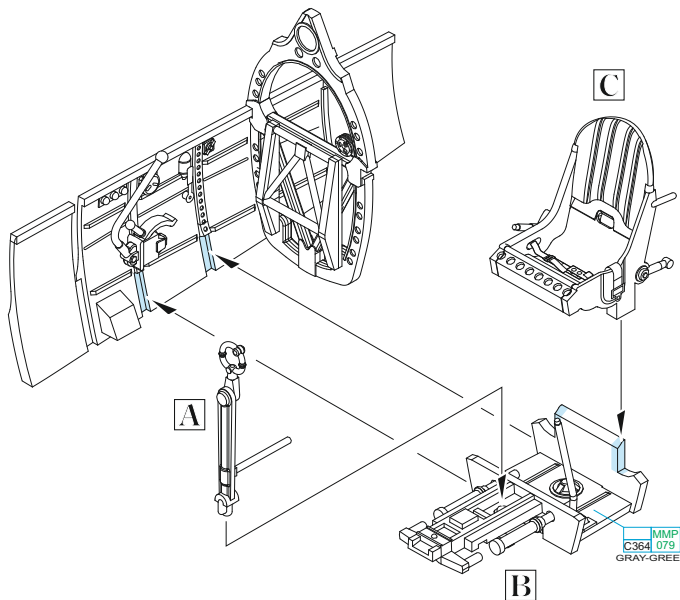

decal 74, 75, 83 ? PE1 - MARKINGS **D-J**  
 decal 74, 83, 84 ? PE2 - MARKINGS **A-C**

OPTIONAL: decal 74, 75, 83 ? 74, 83, 84

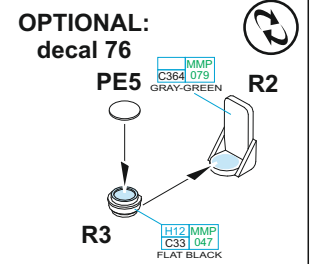
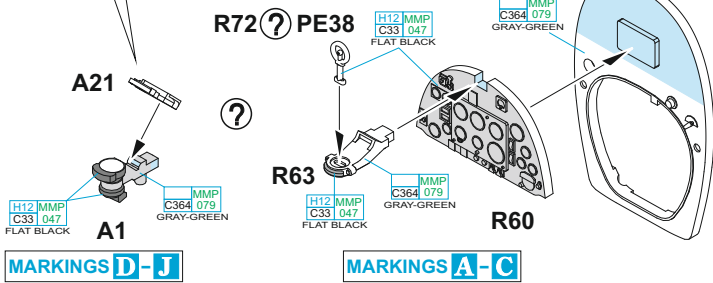

OPTIONAL:  
 decal 76

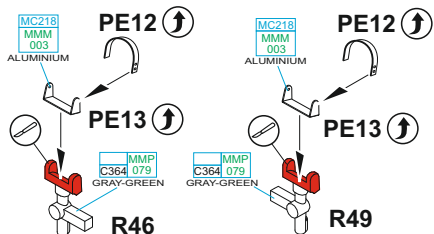
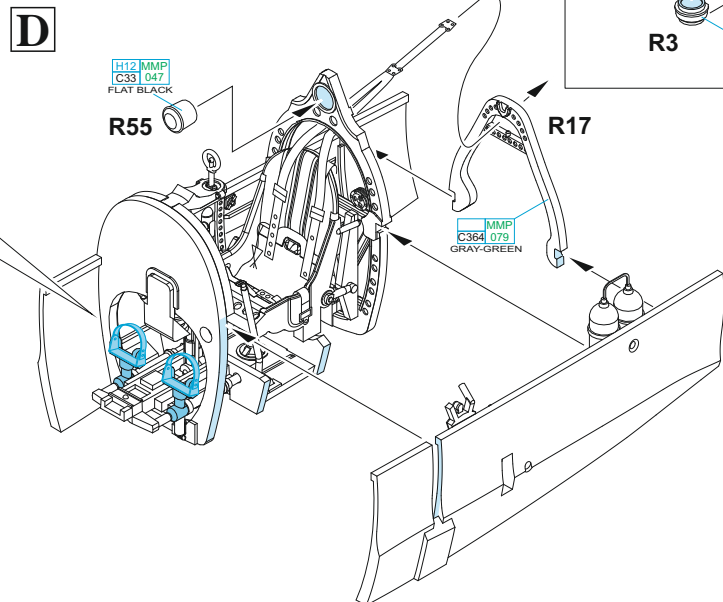
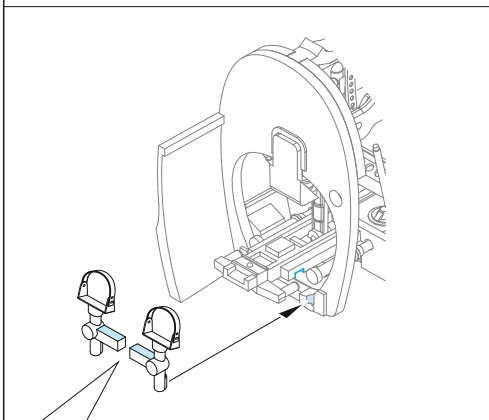

FOR CLOSED CANOPY ONLY

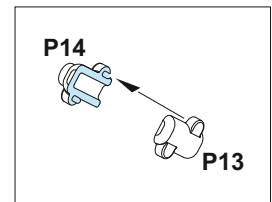
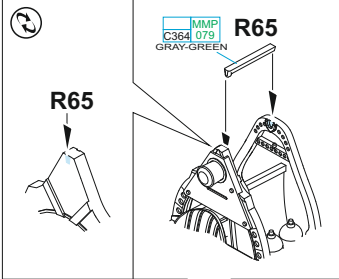
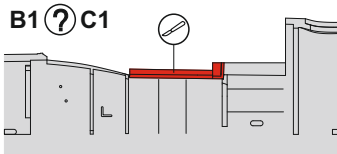
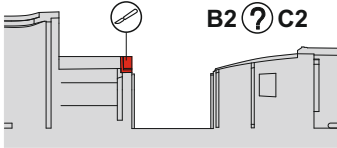

B1 - MARKINGS A-C  
C1 - MARKINGS D-J

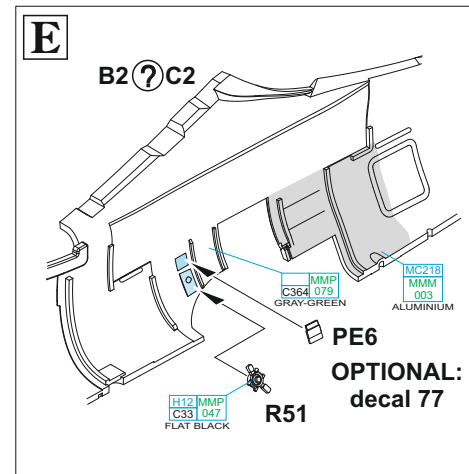
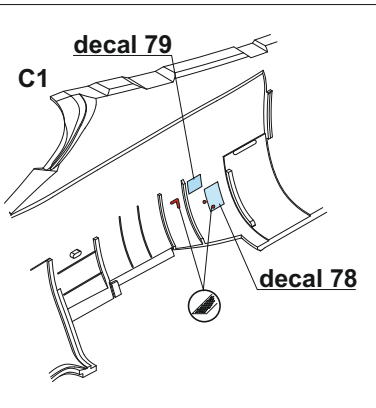
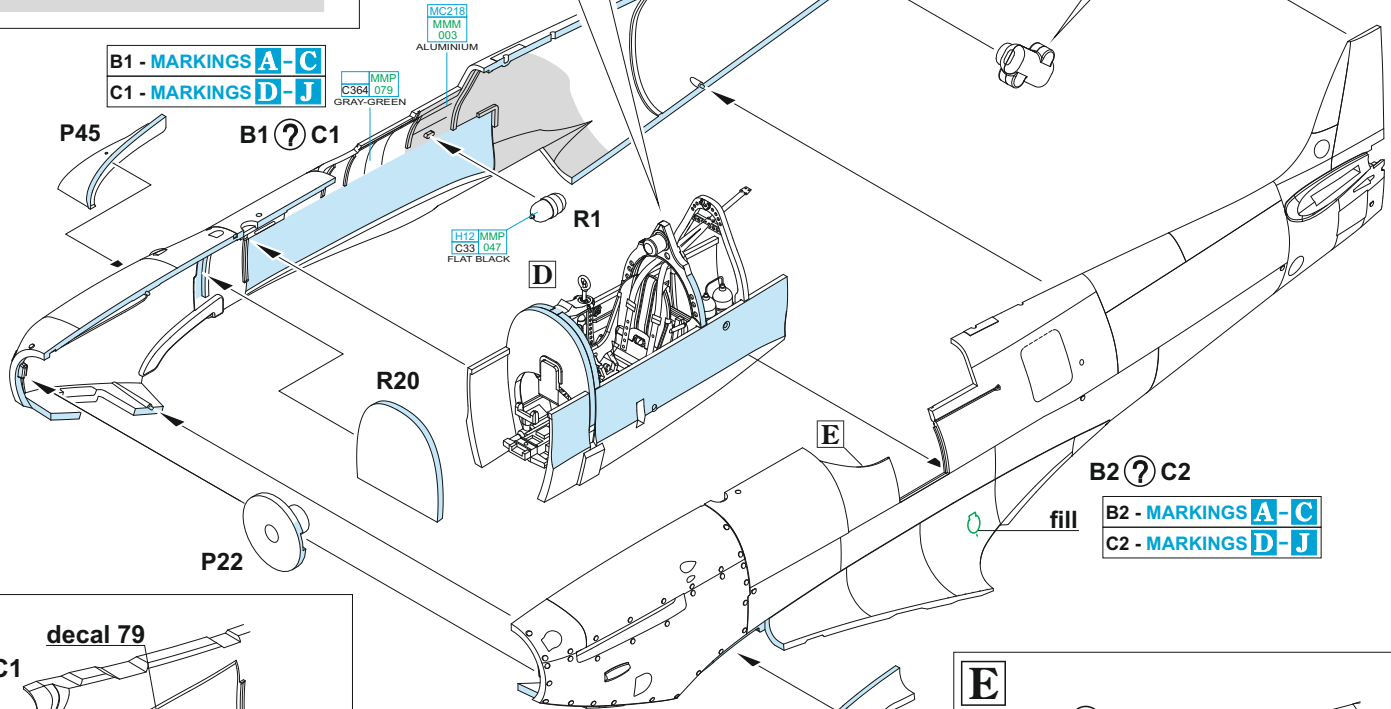

∅ - 0,9 mm MARKINGS C-J ONLY

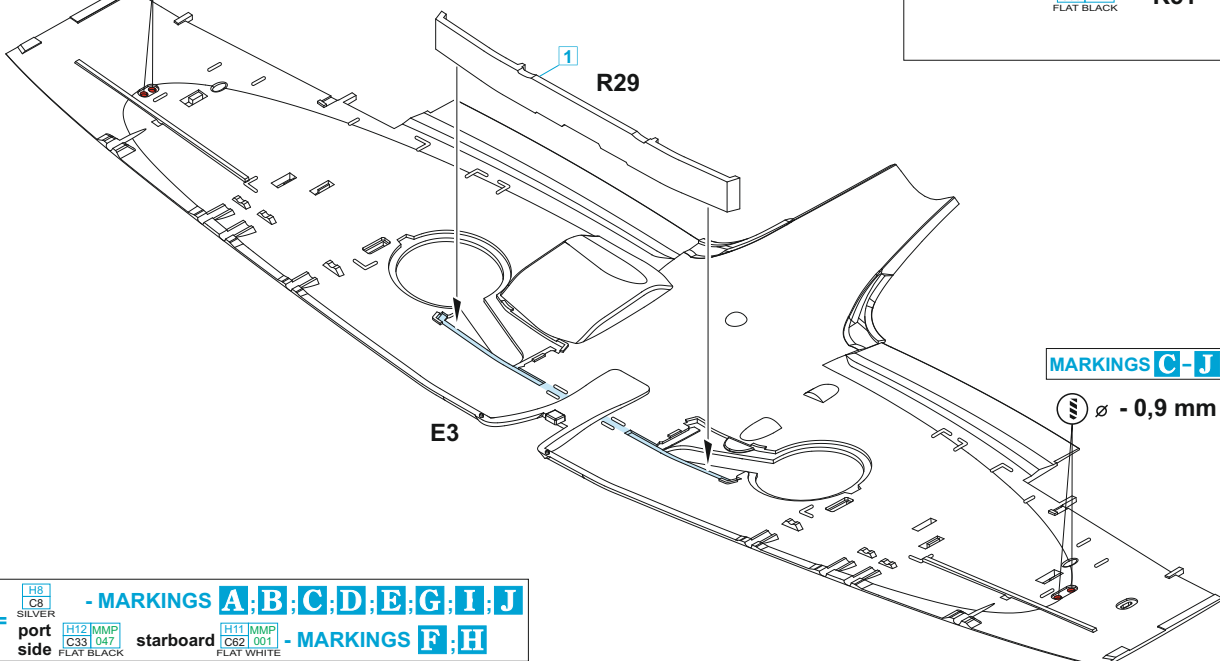

1 = H8 C8 SILVER - MARKINGS A:B:C:D:E:G:I:J  
port side H12 MMP C33 047 FLAT BLACK starboard H11 MMP C62 001 FLAT WHITE - MARKINGS F:H

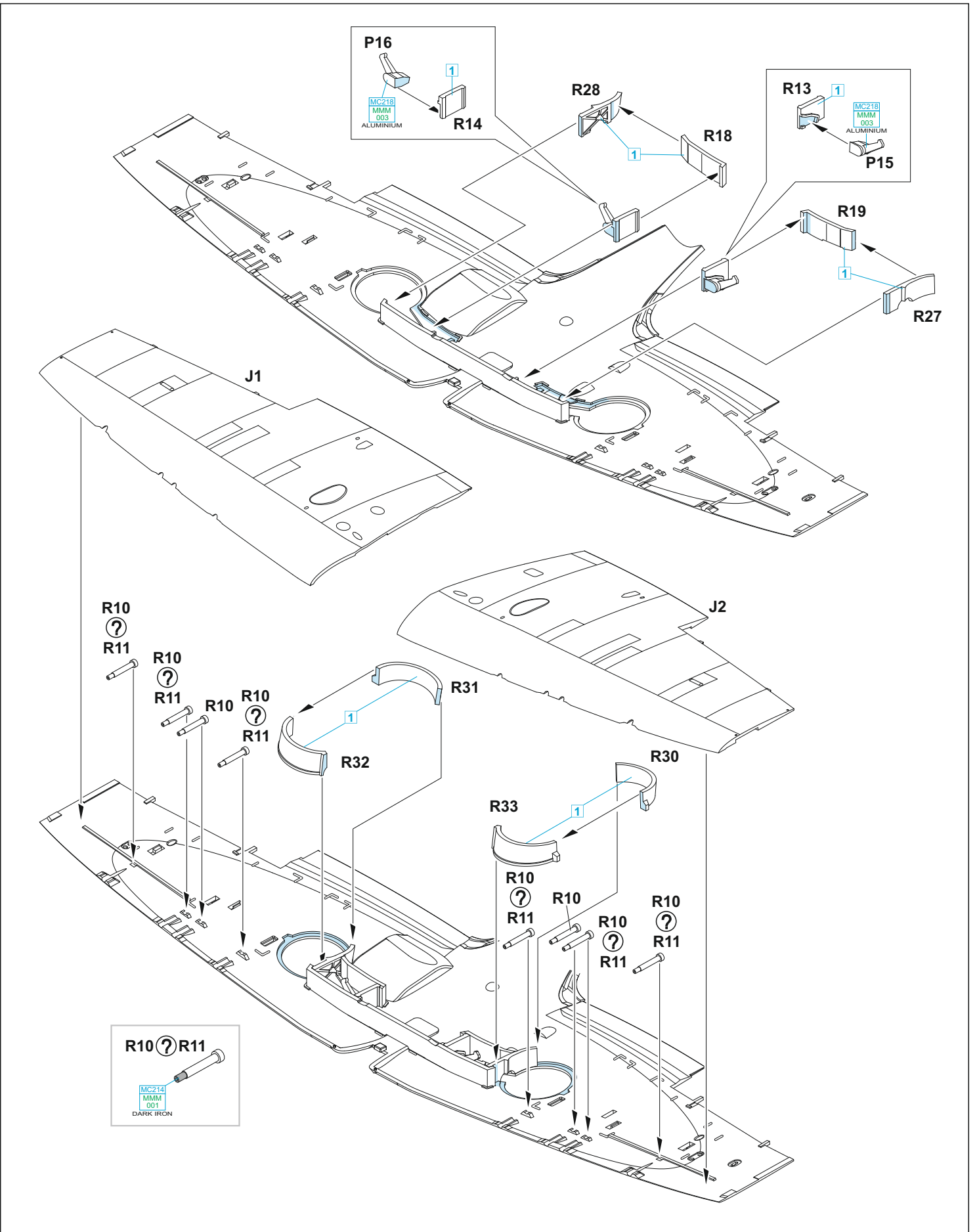

**MARKINGS A-C**

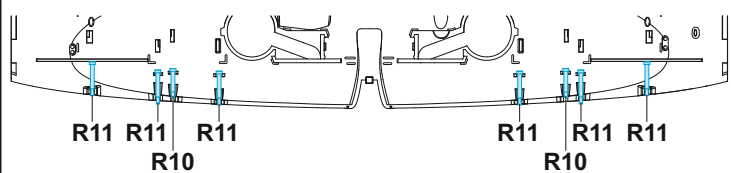

**MARKINGS D-J**

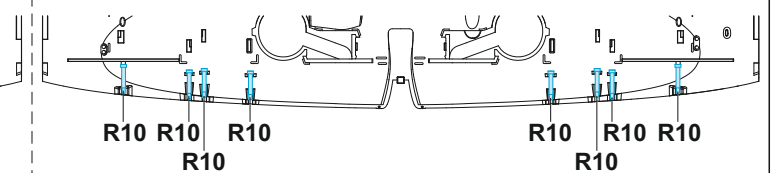



PE29 - MARKINGS **A;B** ONLY

PE29

H12 MMP  
C33 047  
FLAT BLACK

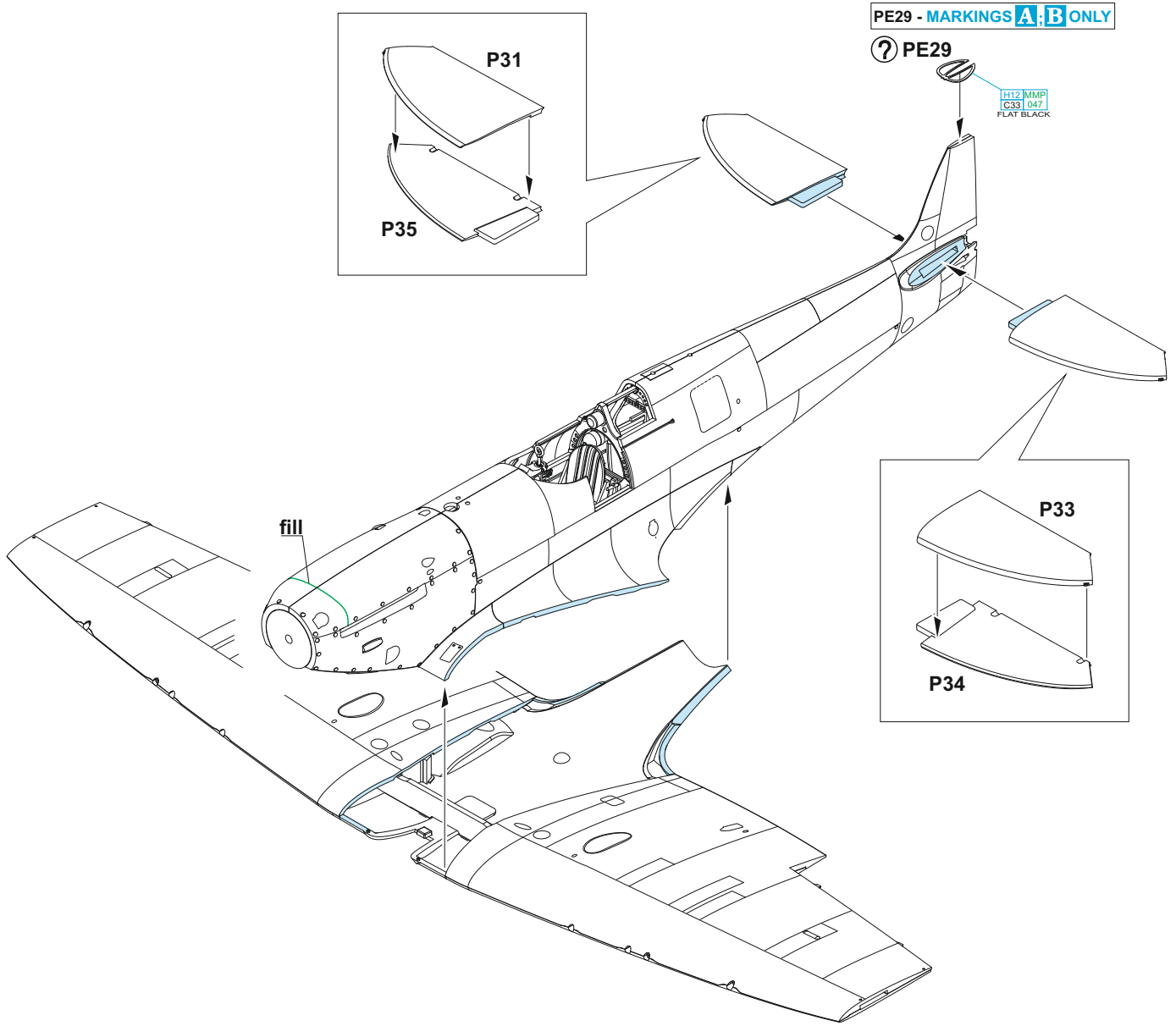
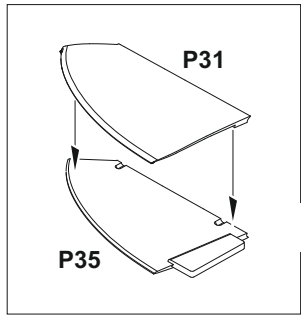

GLUE PARTS P40 & P41  
ONE BY ONE

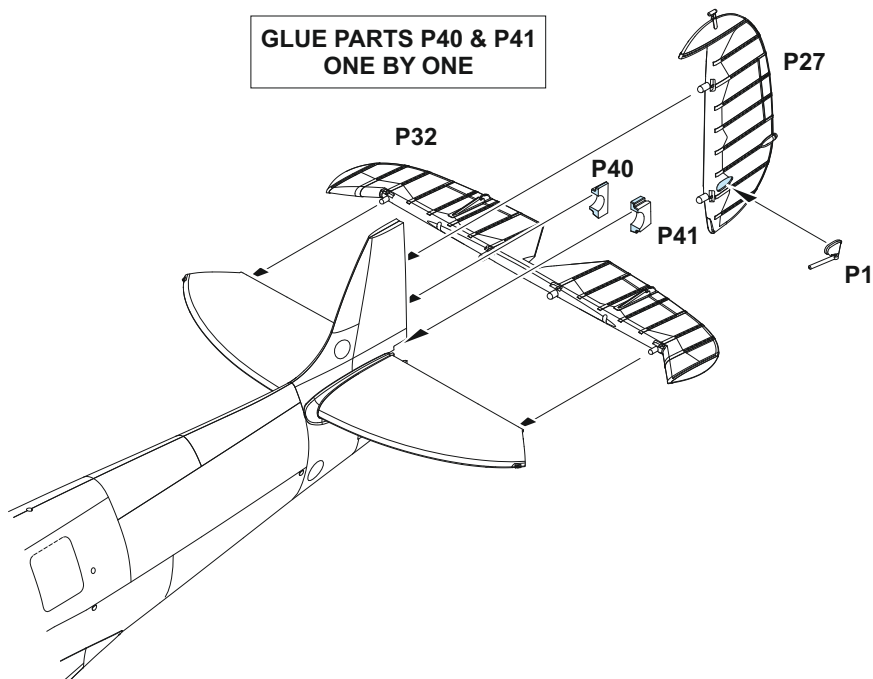

P25

H84  
C138  
CLEAR GREEN

P39

PE31 (↑) (?) PE20, PE31 - MARKINGS A-C ONLY

(?) PE20

PE20 (?)

P37

P28

H86  
C47  
CLEAR RED

MARKING D ONLY

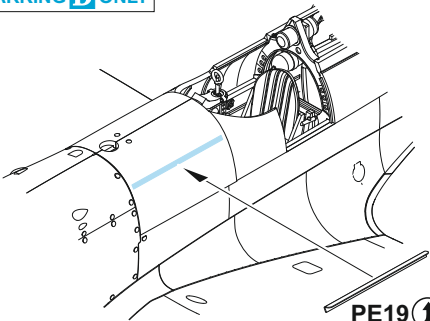

PE19 (↑) (↔)

F

PE36

PE35

P43

(?) MARKINGS C-J ONLY

G

P7

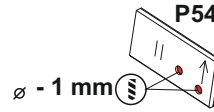

∅ - 1 mm

P6

P18 - MARKINGS A, B ONLY

P18 (?) P19

PE30 (?) PE43 PE43 - MARKINGS C-J ONLY

P72, PE34 - MARKINGS C-J ONLY

P72

PE34

F

P54

P52

P20 (?) P21 P20 - MARKINGS A, B ONLY

PE30

P74

P73

P73, PE11 - MARKINGS C-J ONLY

PE11

G

P29

**?** MARKINGS **C-J** ONLY

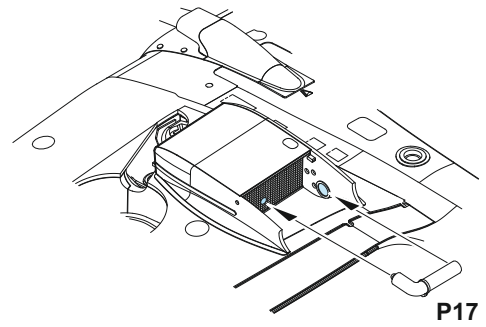
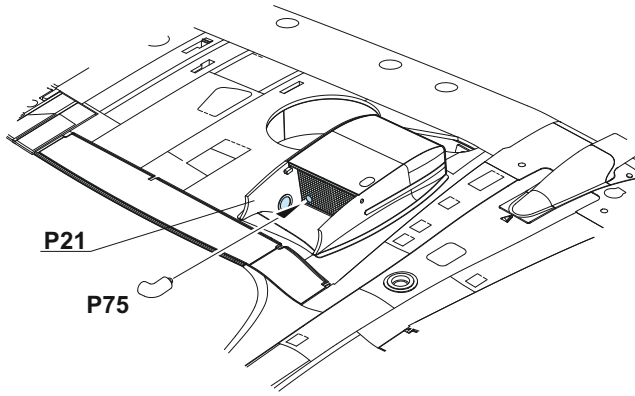

**2 pcs.**

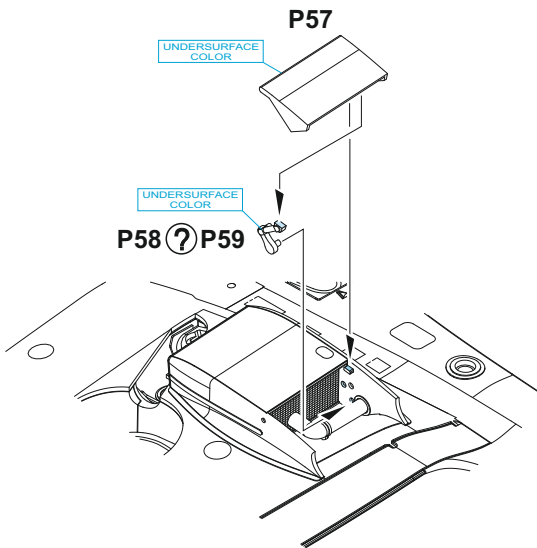
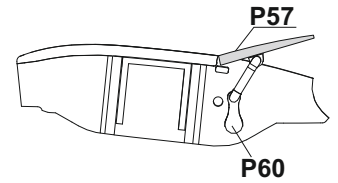
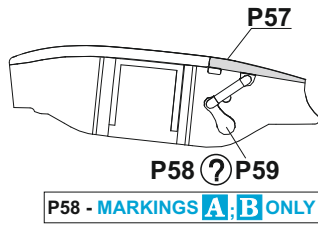
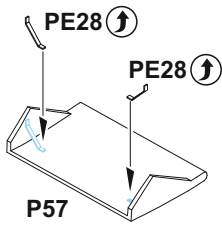

**?**

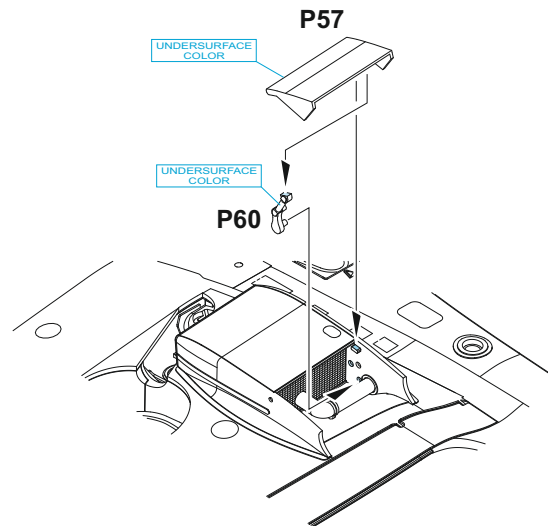

**2** = **UNDERSURFACE COLOR - MARKING **F****  
HR C8 SILVER **- MARKINGS **A;B;C;D;E;G;H;I;J****

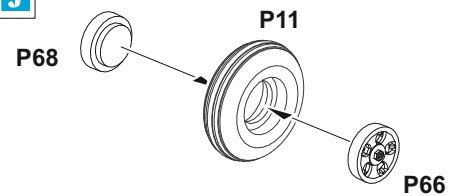
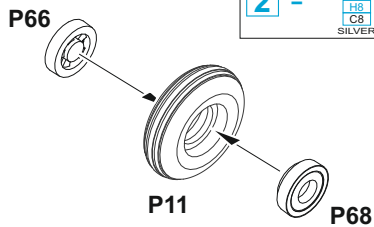

**H**

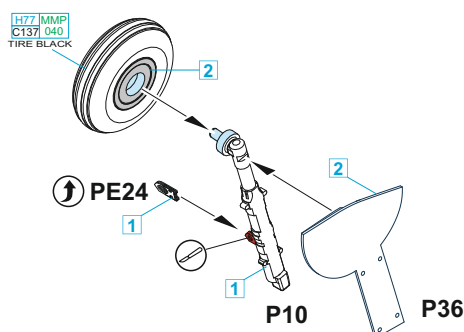

**I**

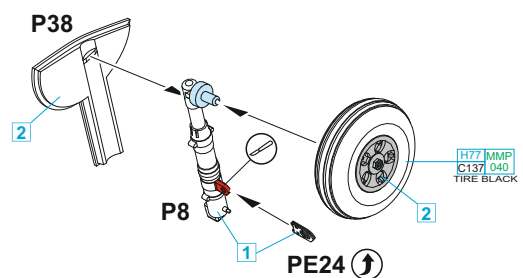

R4 - MARKINGS E, F, H-J

R5 - MARKINGS A-D, G

R4 ? R5

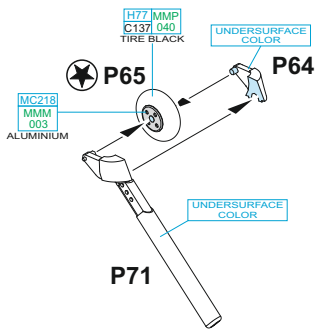
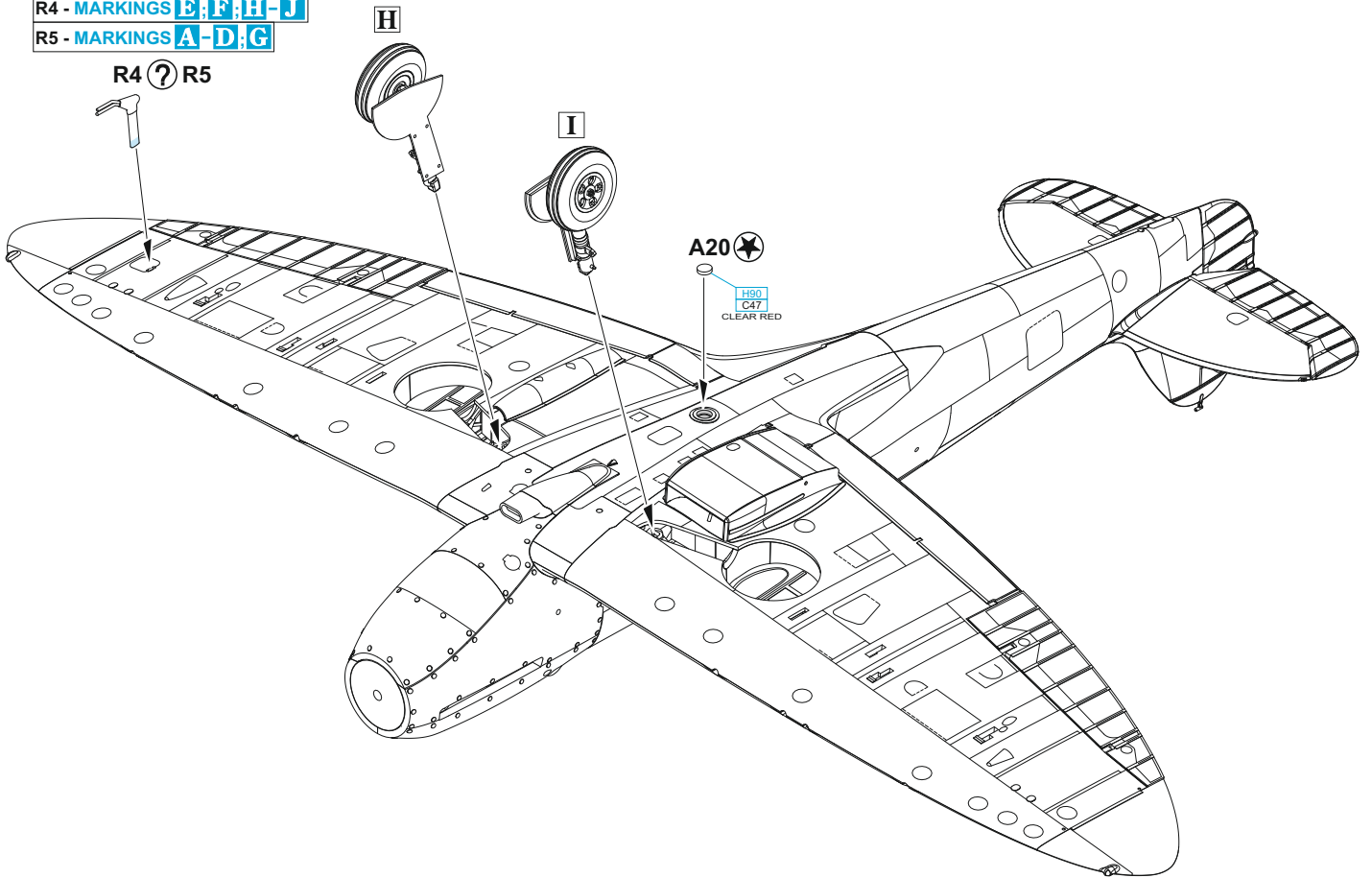

?

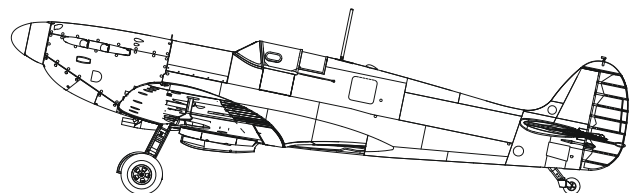
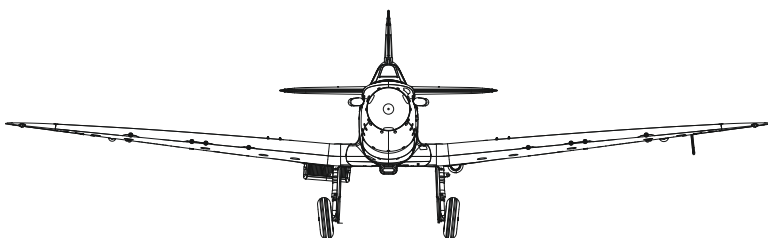
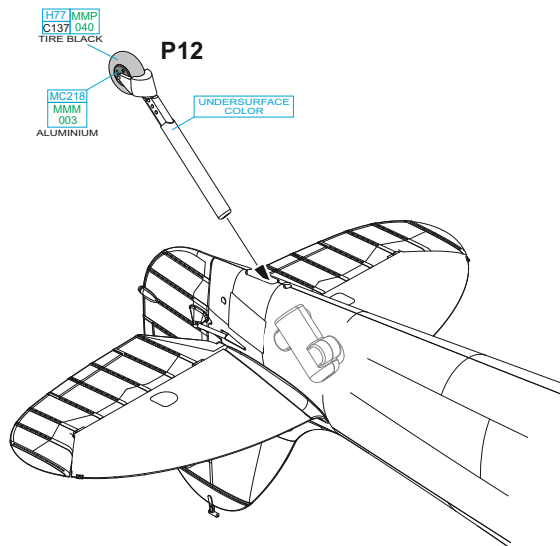

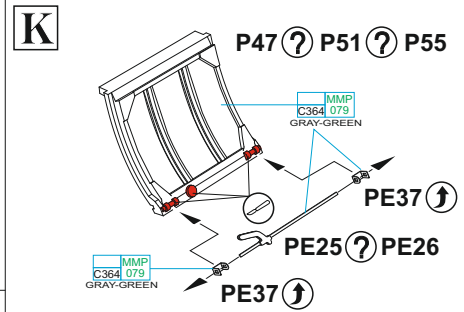
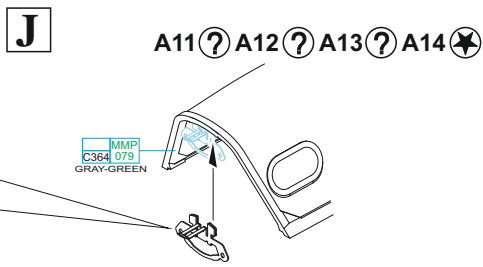
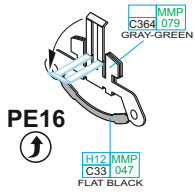

**MARKINGS A-C**

**OPEN CANOPY**

A11 - MARKINGS **A; B**  
A13 - MARKING **C**

A11 ? A13

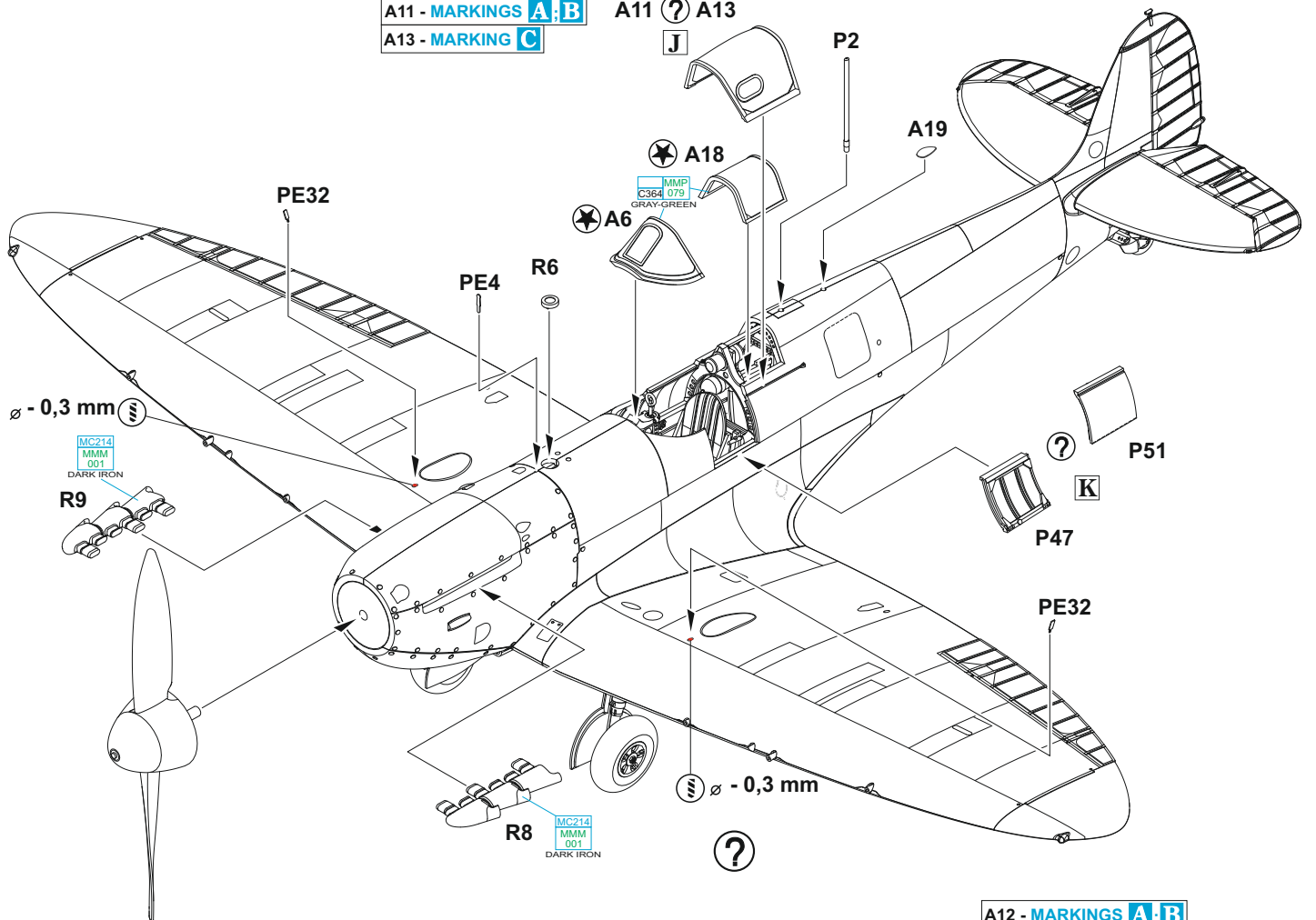

PE25 - MARKINGS **A-D; G**  
PE26 - MARKINGS **E; F; H-J**

**CLOSED CANOPY**

A12 ? A14 \*

A12 - MARKINGS **A; B**  
A14 - MARKING **C**

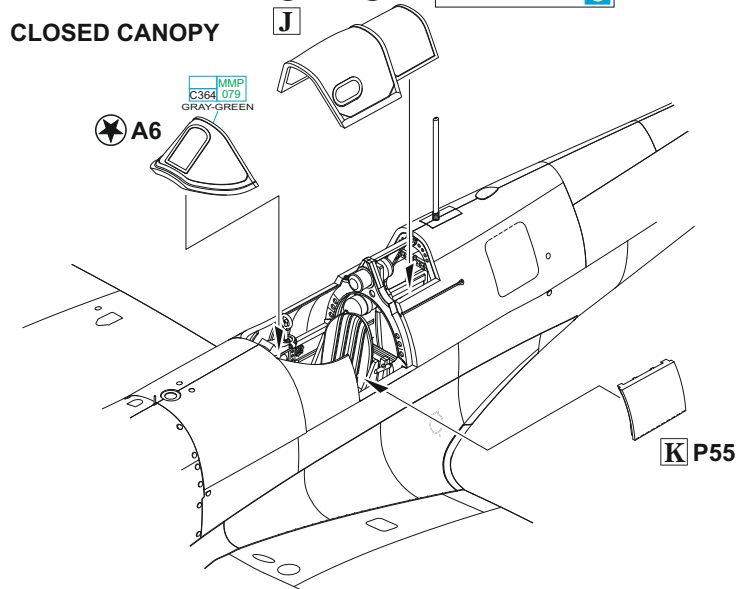
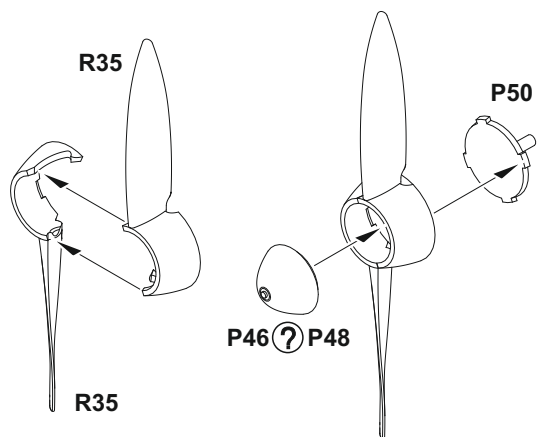

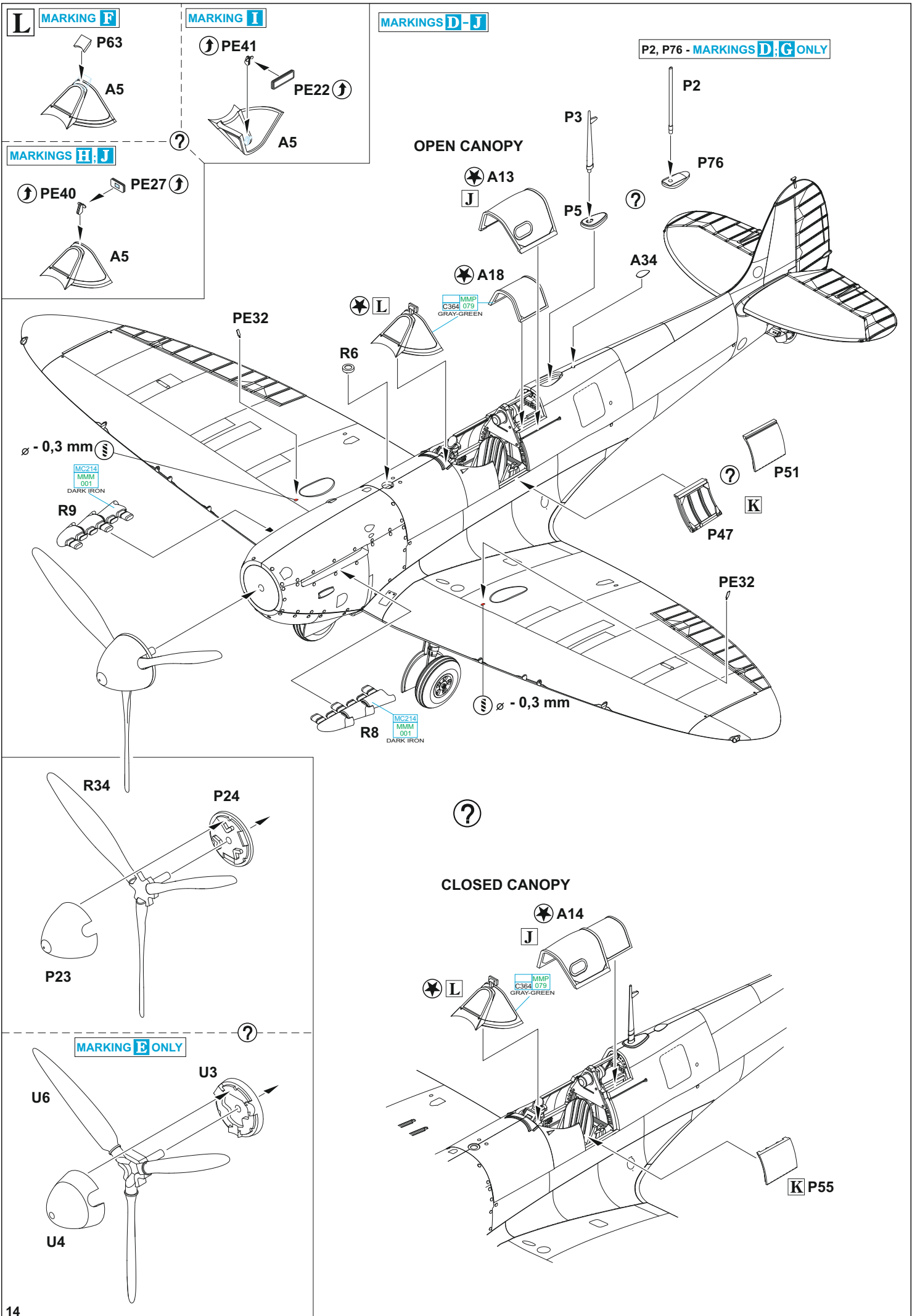

? MARKINGS **A-D;G**

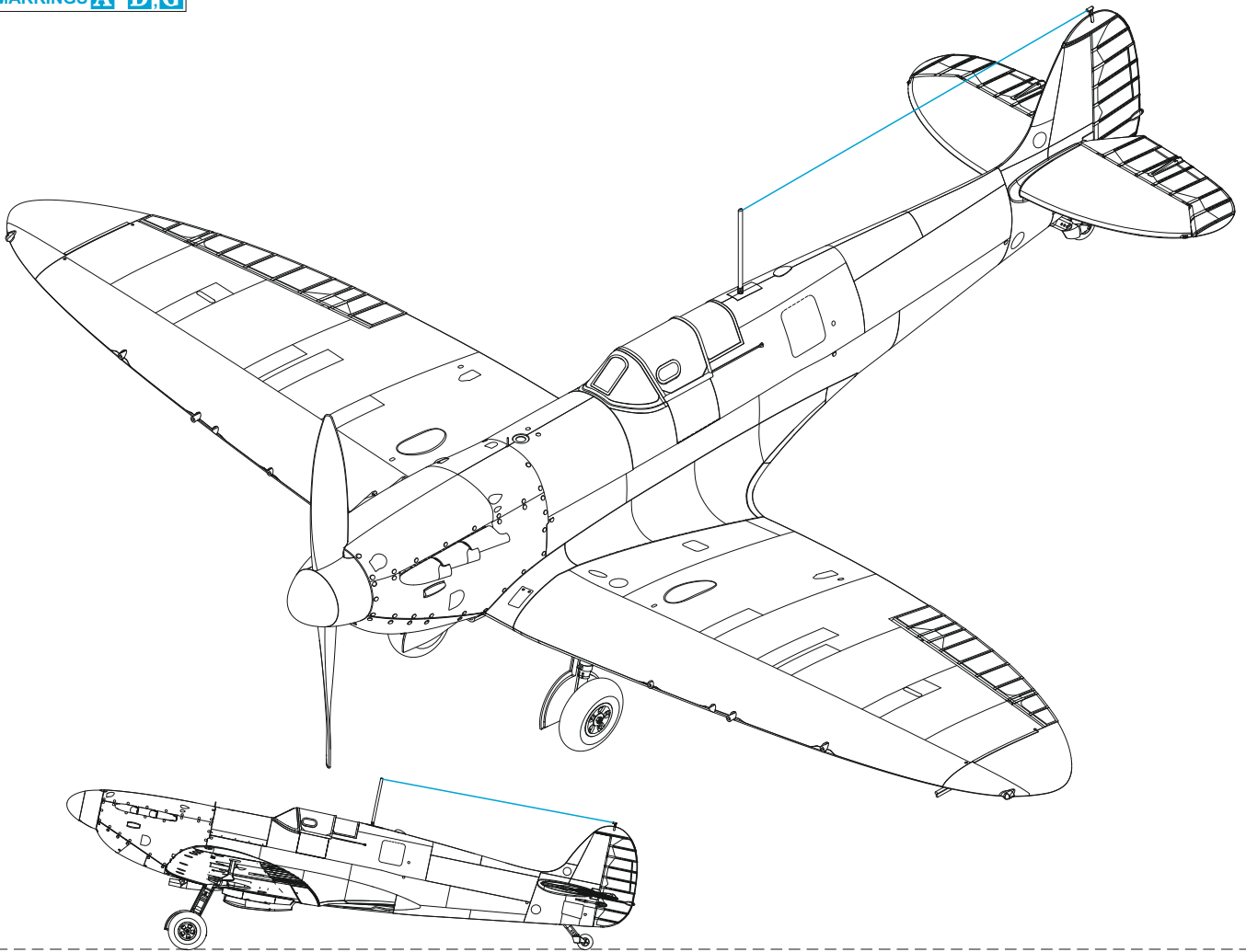

? MARKINGS **F;H-J**

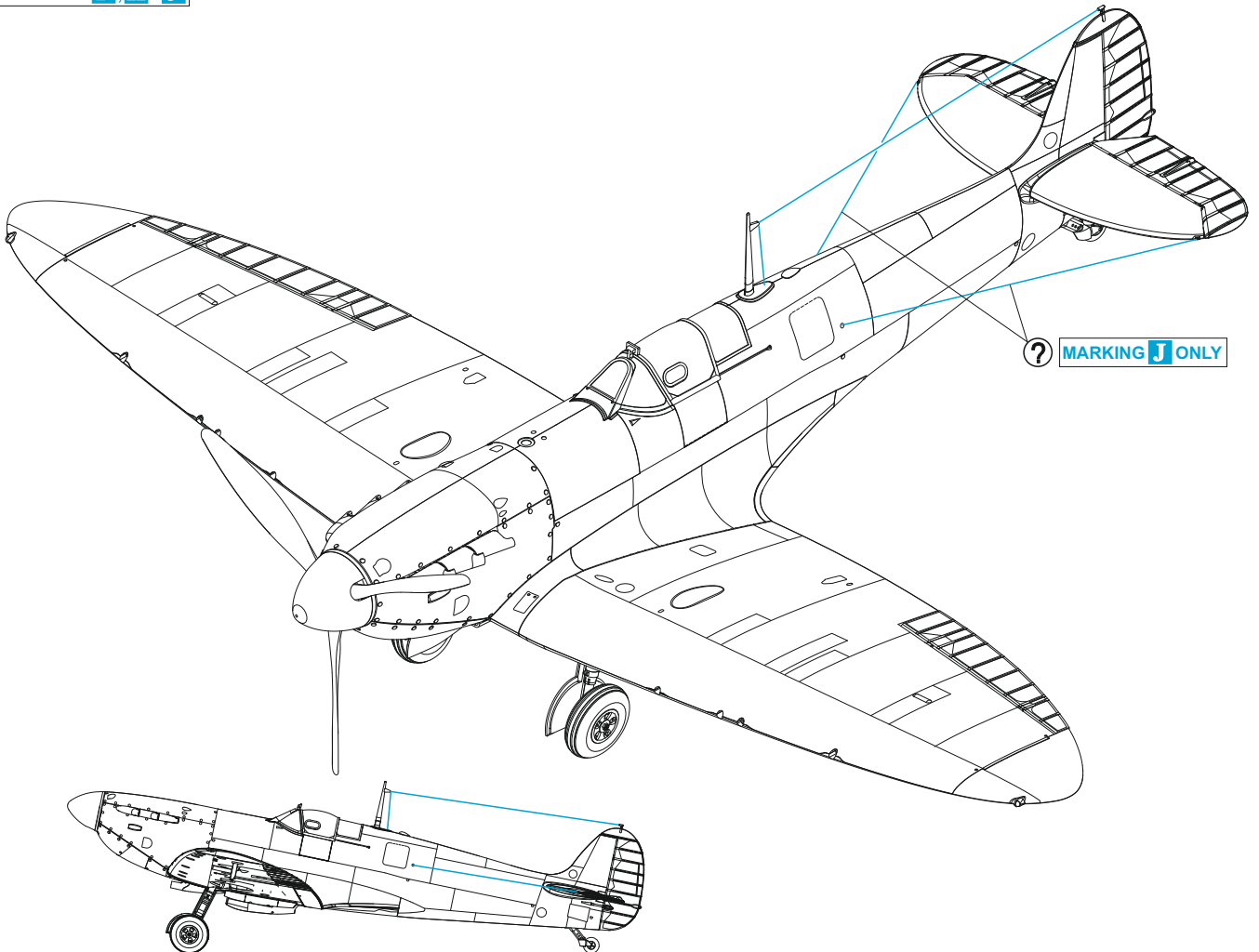



RP1

RP2

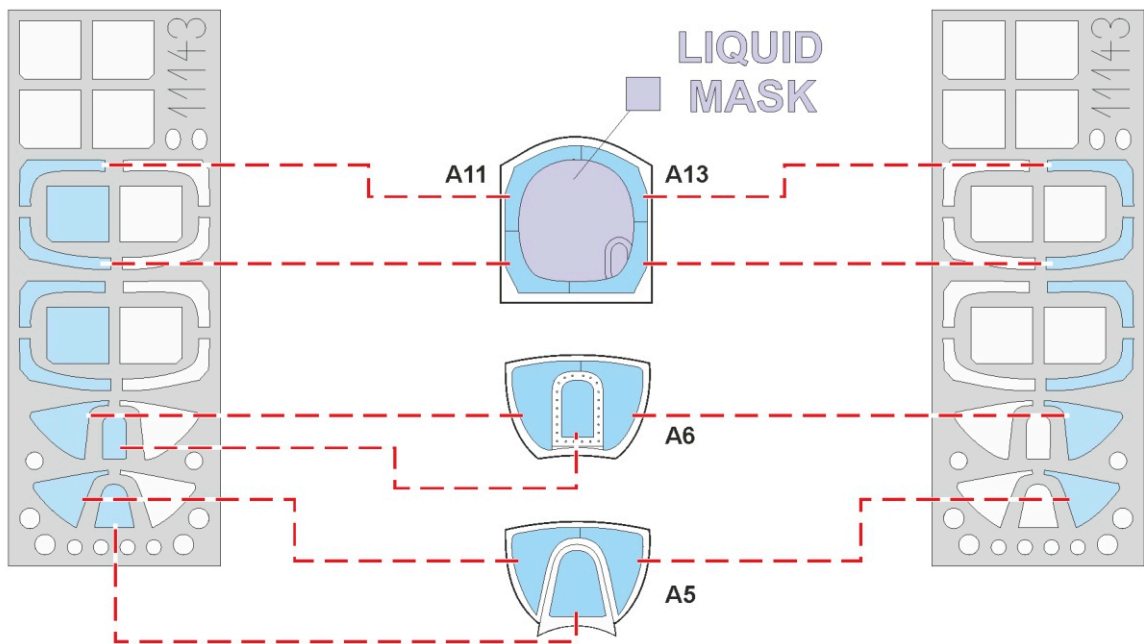
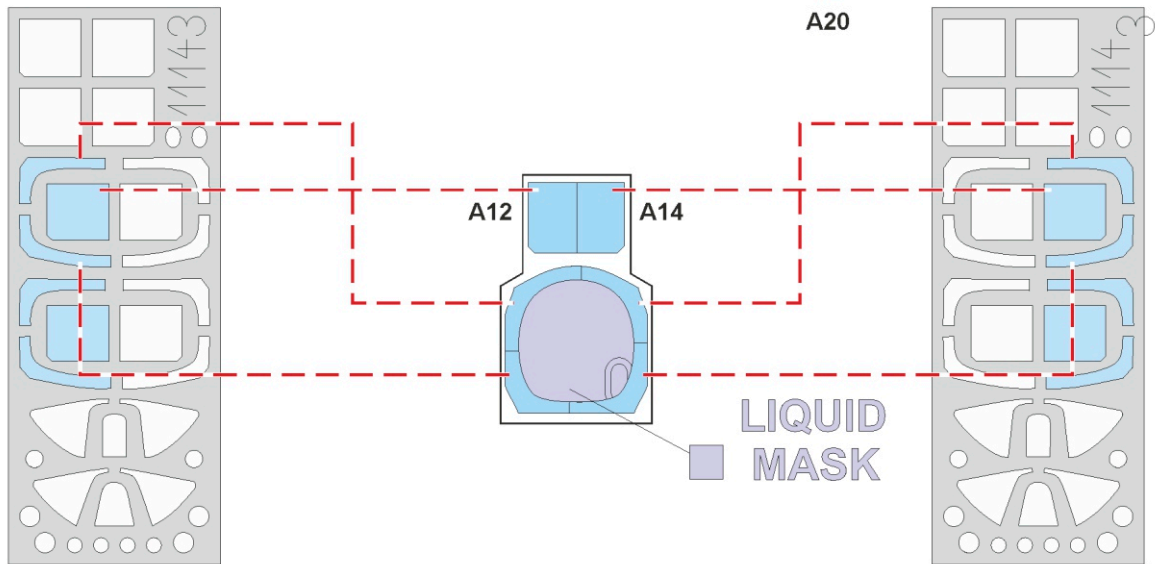
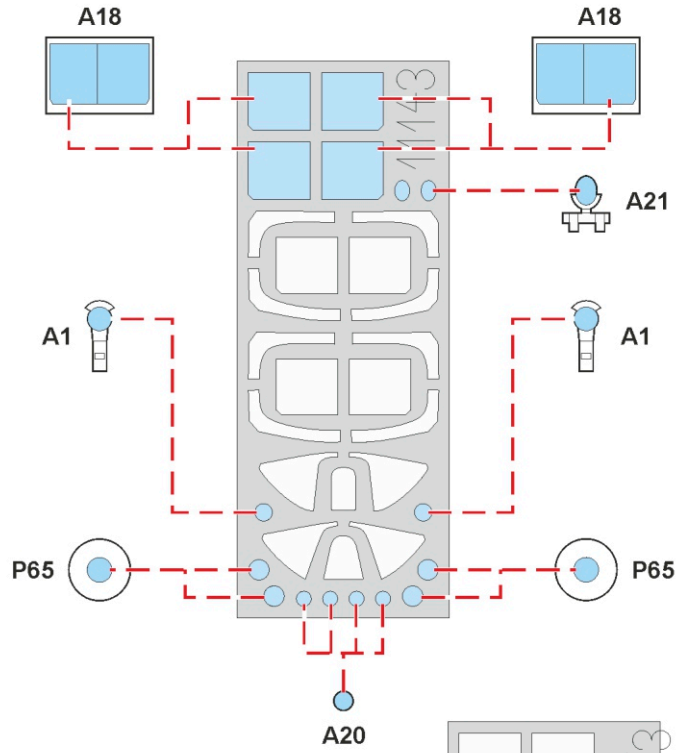



# A K9795, No. 19 Squadron, RAF Duxford, Cambridgeshire, October 1938

No. 19 Squadron was the first RAF unit to reinforce its arsenal with Spitfires. Two reasons influenced this decision: the airfield dimensions in Duxford and the personality of S/Ldr Henry Cozens, who was a qualified aircraft engineer, fully competent to collaborate with Supermarine engineers on the improvements of the Spitfire design. Cozens himself flew the Spitfire K9789 for the first time on August 11th, 1938. The represented camouflage and markings were used by No. 19 Squadron on October 31st, 1938, when new unit's Spitfires were officially photographed from a Blenheim Mk.I. Note the Cozens K9794 was already equipped with the bulged canopy, which was officially introduced a few months later in January 1939. The squadron suffered its first loss on November 3rd, 1938, when P/O Sinclair, who was later a CO of A-flight of No. 310 (Czechoslovak) squadron, destroyed his Spitfire Mk.I K9792 during landing. Pay attention to the interesting feature on the leading edge of the vertical stabilizer, which prevented the parachutes strings to entangle in case of an emergency bail out.

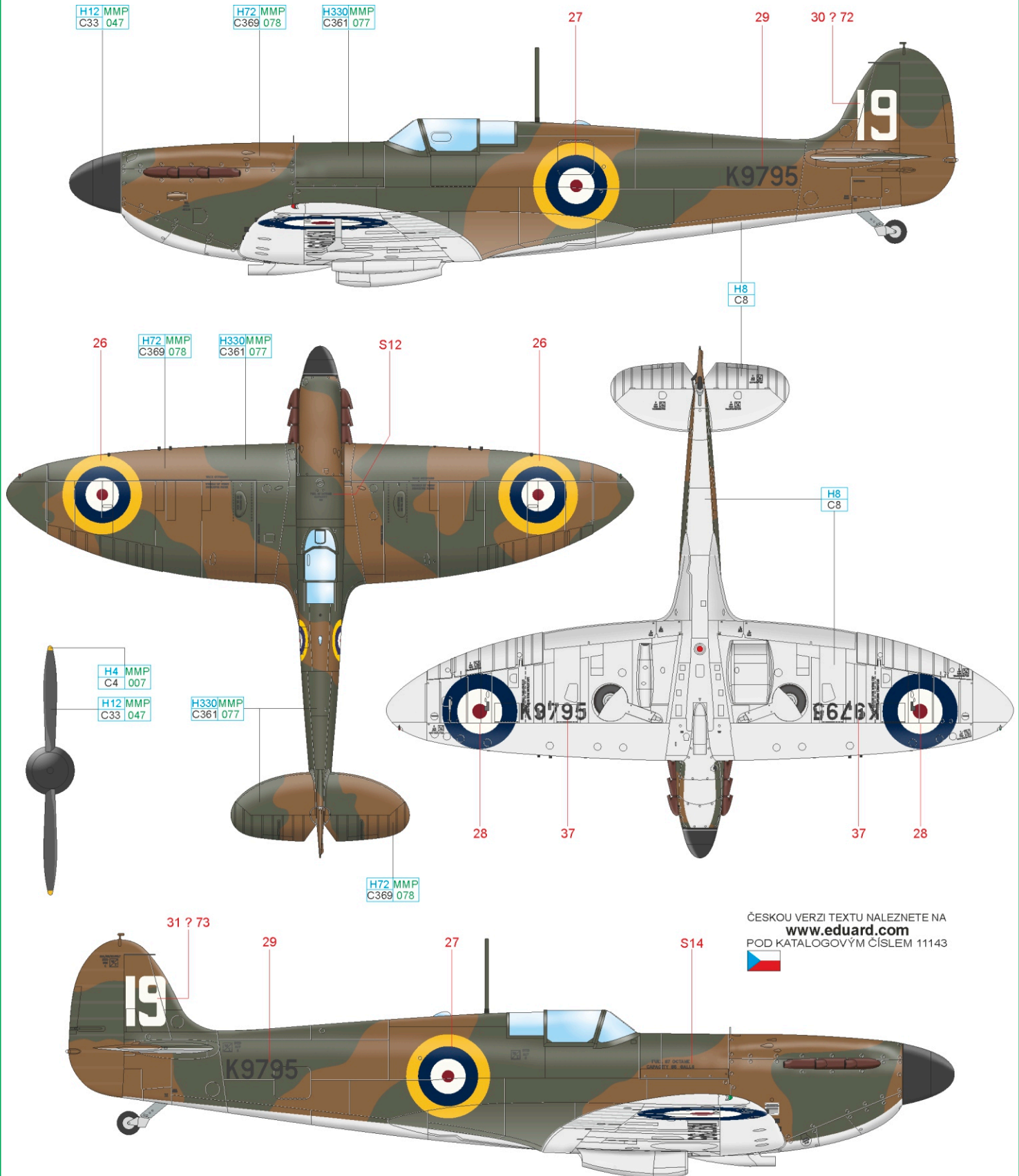

ČESKOU VERZI TEXTU NALEZNETE NA  
[www.eduard.com](http://www.eduard.com)  
 POD KATALOGOVÝM ČÍSLEM 11143



SILVER	H8 C8	YELLOW	H4 MMP C4 007	DARK EARTH	H72 MMP C369 078	DARK GREEN	H330 MMP C361 077	BLACK	H12 MMP C33 047
--------	-------	--------	---------------	------------	------------------	------------	-------------------	-------	-----------------

# B No. 41 Squadron, RAF Catterick, North Yorkshire, Spring 1939

The No. 41 Squadron acquired their first two Spitfires Mk.I K9831 and K9832 on December 30th, 1938 as third Fighter Command unit. This Spitfire Mk.I PN-M has a colorway from the spring of 1939, with red-blue national insignia on the upper surfaces, former white and yellow rings are oversprayed with camouflage color. Technically the aircraft displays first clean serial finish, with Merlin II engine, Weybridge two-blade wooden propeller, flat canopy, and the original old style Pitot tube. The plane doesn't have the machine gun heating and was flown without any armor. This aircraft had an external camera gun on the upper side of the right wing. Until September 3rd, 1939, the day when UK declared war to Germany, in total 306 Spitfires Mk.I were brought into RAF, 187 of them served in eleven Fighter Command squadrons. Of these units, only seven were battle-ready two days after the war began, and four others were in the process of reinforcement and upgrades. 36 Spitfires were lost before the war during various accidents. After the war broke out, all the Spitfire equipped squadron remained based in British islands as part of Air Defense of Great Britain.

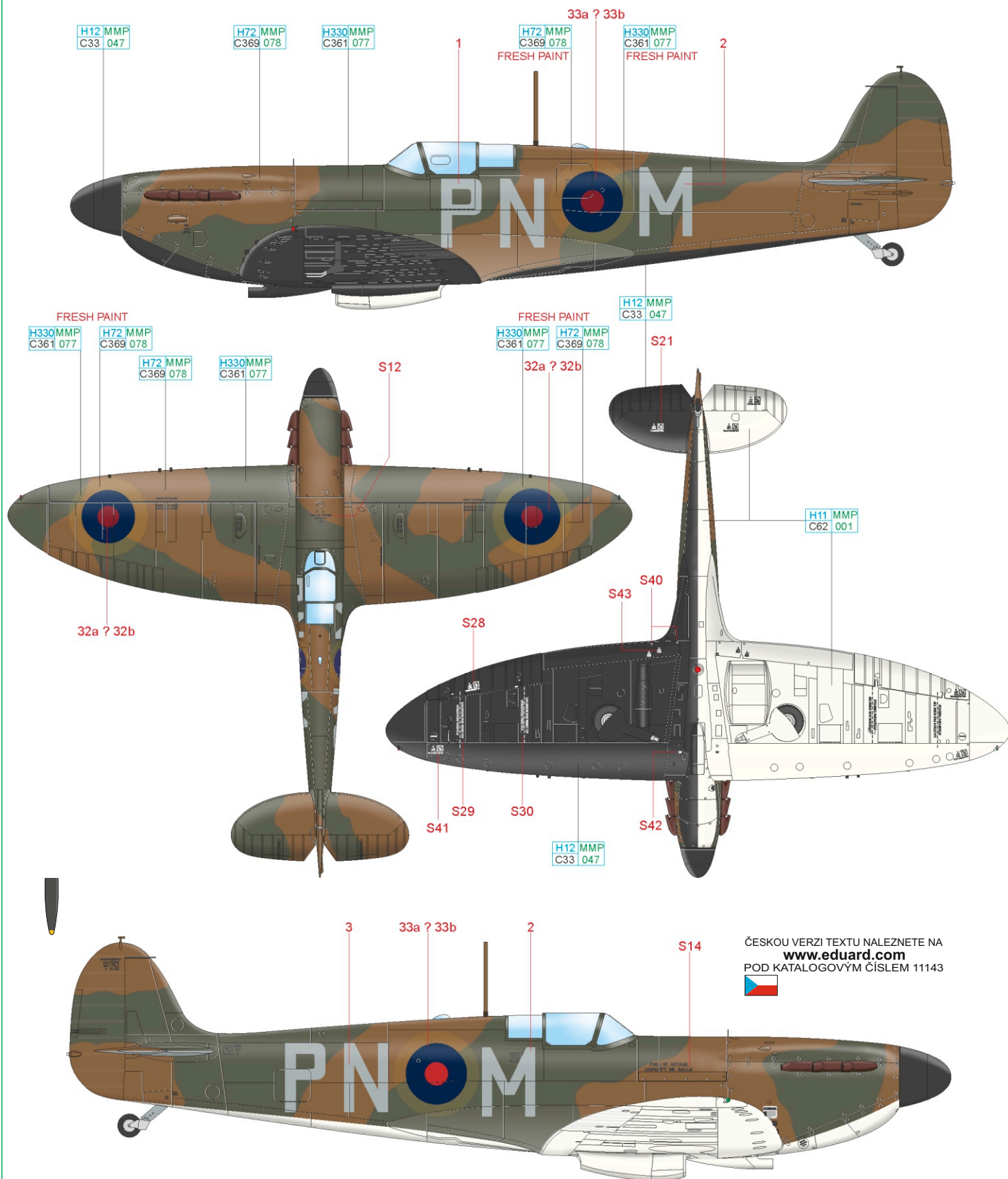

ČESKOU VERZI TEXTU NALEZNETE NA  
[www.eduard.com](http://www.eduard.com)  
 POD KATALOGOVÝM ČÍSLEM 11143



WHITE	H11 MMP C62 001	YELLOW	H4 MMP C4 007	DARK EARTH	H72 MMP C369 078	DARK GREEN	H330 MMP C361 077	BLACK	H12 MMP C33 047
-------	--------------------	--------	------------------	------------	---------------------	------------	----------------------	-------	--------------------

# C K9906, flown by F/O Robert Stanford Tuck, No. 65 Squadron, RAF Hornchurch, Essex, Summer 1939

This Spitfire Mk.I already has the bulged canopy, three-blade propeller De Havilland and machine-gun heating. Still remains without any armor, having the old type of Pitot tube and a mechanical gunsight. F/O Tuck is the most accomplished fighter ace in our lineup with 29+2 kills. In May 1940 he was reassigned to No. 92 Squadron, his first three kills came at in May 1940 over Dunkirk. He was promoted S/Ldr of No. 257 Squadron flying Hurricane Mk.IIs on September 11th. It is rumored one of his victims was the future fighter ace of Luftwaffe, Hans-Joachim Marseille (September 23rd, 1940). He was shot down near Boulogne sur Mer and captured on January 28th, 1942. He participated in the organization of the Big escape in Stalag Luft III POW camp in Sagan, but just before the escape he was transferred to Belaria camp. On the February 1st, 1945, he managed to escape during camp evacuation and joined the Russians, when his knowledge of the Russian language was an essential advantage. He retired from the RAF in Fifties and took up farming. During the shooting of Battle of Britain movie he befriended Adolf Galland, he was his son's godfather. He died on May 5th, 1987 at the age of 70.

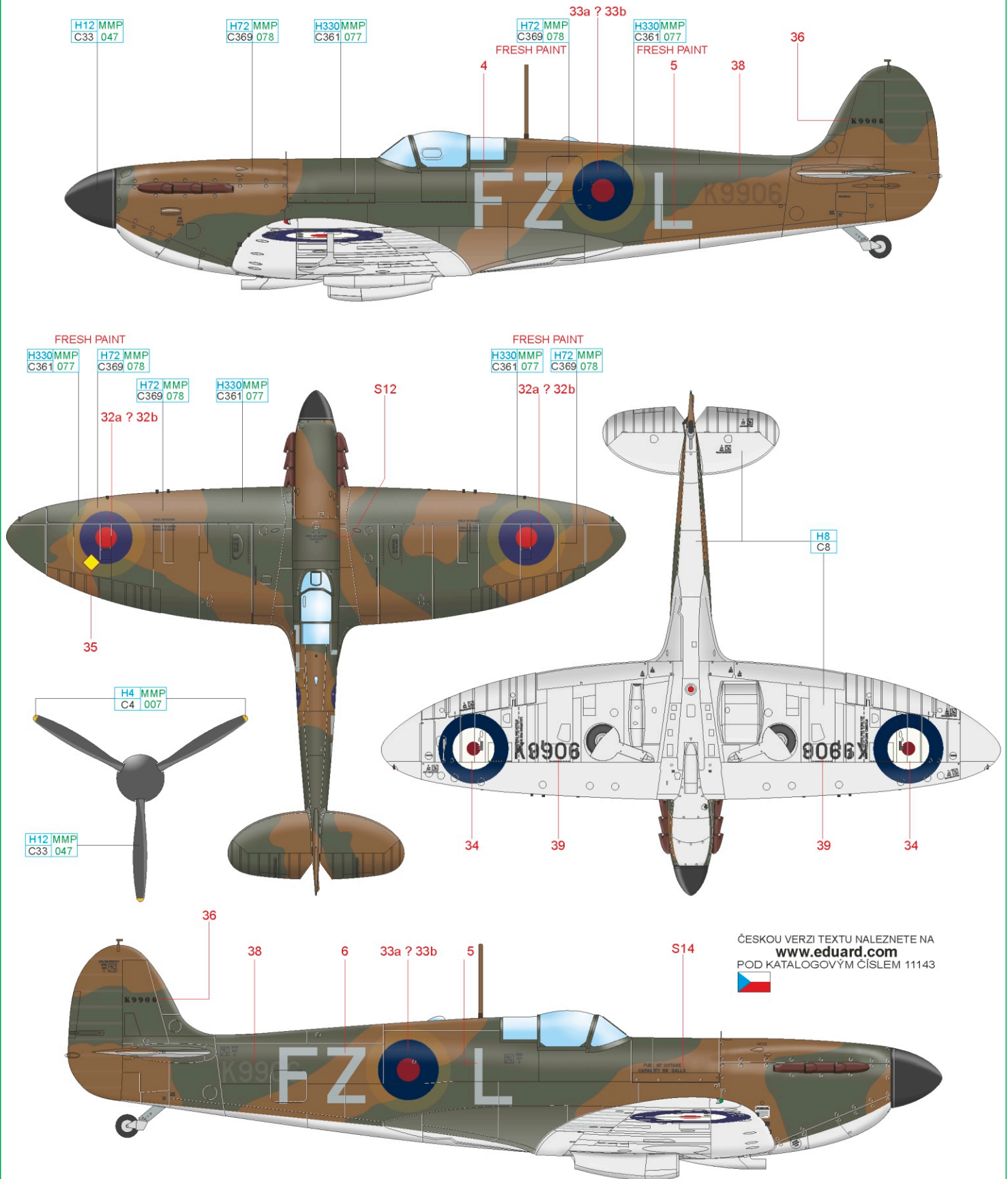

SILVER	H8 C8	YELLOW	H4 MMP C4 007	DARK EARTH	H72 MMP C369 078	DARK GREEN	H330MMP C361 077	BLACK	H12 MMP C33 047
--------	----------	--------	------------------	------------	---------------------	------------	---------------------	-------	--------------------

ČESKOU VERZI TEXTU NALEZNETE NA  
[www.eduard.com](http://www.eduard.com)  
 POD KATALOGOVÝM ČÍSLEM 11143



# D K9955, flown by F/O Archibald Ashmore McKellar, No. 602 Squadron, RAF Drem, East Lothian, Scotland, March 1940

This plane already has a bulletproof windscreen and the new pitot tube, GM 2 gunsight, but still has older type of the antenna mast. The pilot seat is still without any armor. Note the anti-spin slat on the side of the fuselage fuel tank. No. 602 Squadron had their Merlin II engines altered for 100 octane fuel already in February 1940. No. 602 Squadron, part of the Auxiliary Air Force, acquired Spitfires before the war. On the 16th of October 1939 it took part in the shooting down of the first German aircraft over British territory during the KG 30's air raid on Scapa Flow, and on October 28th shooting down the first German aircraft over the British soil, He 111 over Firth of Forth. Some sources claim McKellar had a part in these takedowns. In the June 1940 he joined No. 605 Squadron equipped with Hurricanes to become Squadron Leader on September 11th. He accomplished 15 kills during the BoB. On October 3rd, 1940 he got 5 wins during a single day, (all above Bf 109E) and became one of 28 Allied Aces in the day. S/Ldr A.A. McKellar died a day after the Battle of Britain officially ended, on November 1st, 1940. It is assumed Hptm. Wolfgang Lippert, CO of II./JG 27, shot him down.

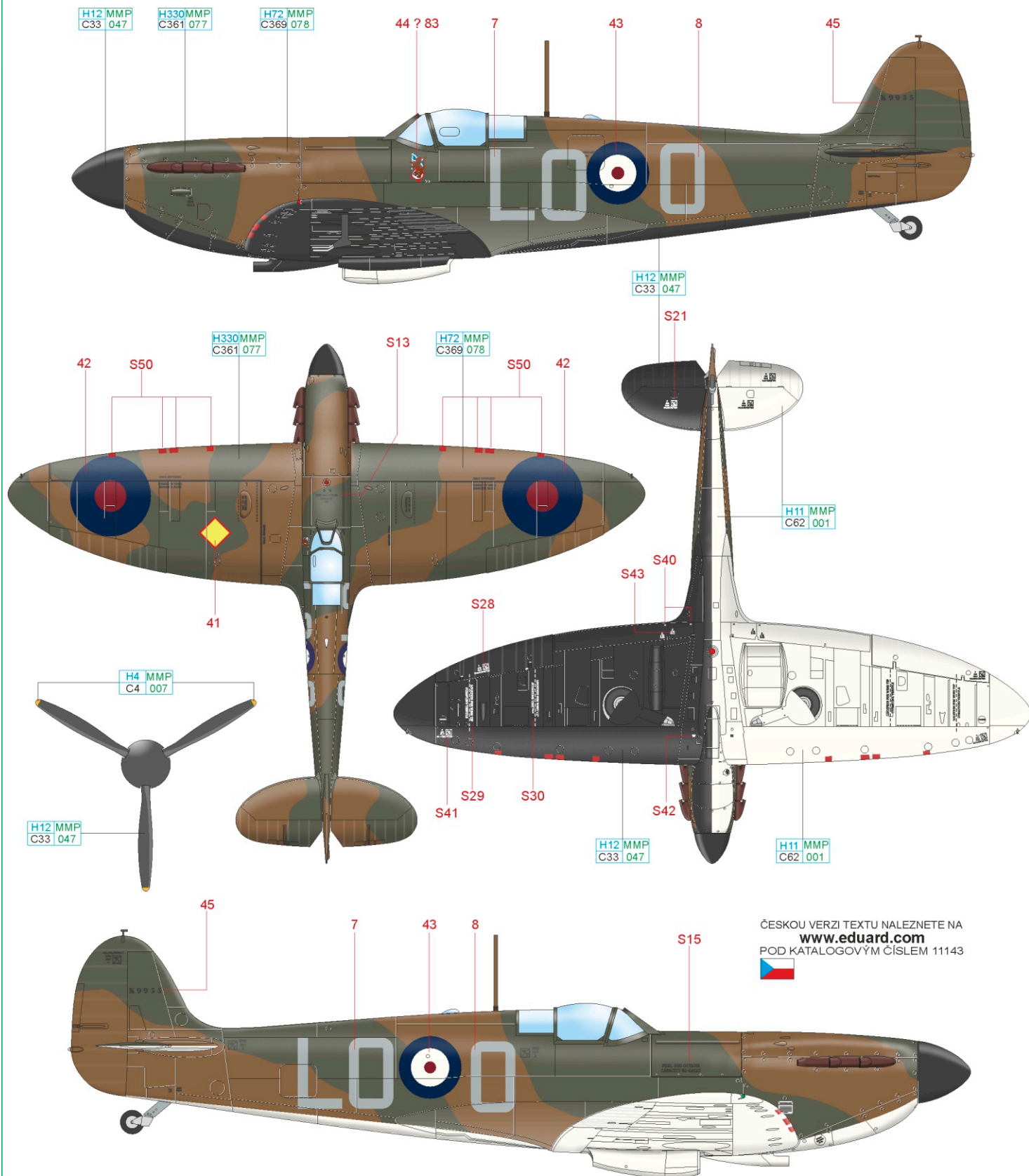

ČESKOU VERZI TEXTU NALEZNETE NA  
**www.eduard.com**  
 POD KATALOGOVÝM ČÍSLEM 11143



- |       |                 |        |               |            |                  |            |                  |       |                 |
|-------|-----------------|--------|---------------|------------|------------------|------------|------------------|-------|-----------------|
| WHITE | H11 MMP C62 001 | YELLOW | H4 MMP C4 007 | DARK EARTH | H72 MMP C369 078 | DARK GREEN | H330MMP C361 077 | BLACK | H12 MMP C33 047 |
|-------|-----------------|--------|---------------|------------|------------------|------------|------------------|-------|-----------------|

# E N3180, flown by P/O Alan Christopher Deere (RNZAF), No. 54 Squadron, RAF Hornchurch, Essex, May 1940

No. 54 Squadron was the only RAF unit equipped solely with Spitfires Mk.I with Rotol RMS 7 constant speed propeller. The New Zealander Deere, who took first flight in Spitfire on March 6th, 1940, participated in the first operation of the No. 54 Squadron, providing air support for the retreating forces in Belgium on the May 16th. On the May 23rd, during the escort of F/Lt. J. Leather, flying in Miles Magister for the No. 74 squadron commander, S/Ldr L. White, shot down near Calais, Deere downed his first two Bf 109s. On the 26th of May, the operation Dynamo began in the evening, the evacuation of Dunkirk. On the 28th of May, Deere had to make an emergency landing on a Belgian beach but managed to get back to Hornchurch after a 19hour trek. After the evacuation of Dunkirk ended, the No. 54 squadron joined the BoB, in which Deere got 7 confirmed kills. During World War Two Deere went through a lot of leadership posts. His total score is at 22 confirmed kills (some sources claim 17 only). He retired as Air Commodore in 1967. A.C. Deere, OBE, one of the most famous New Zealand and British pilots, died on 22nd of September 1995 in the age of 77.

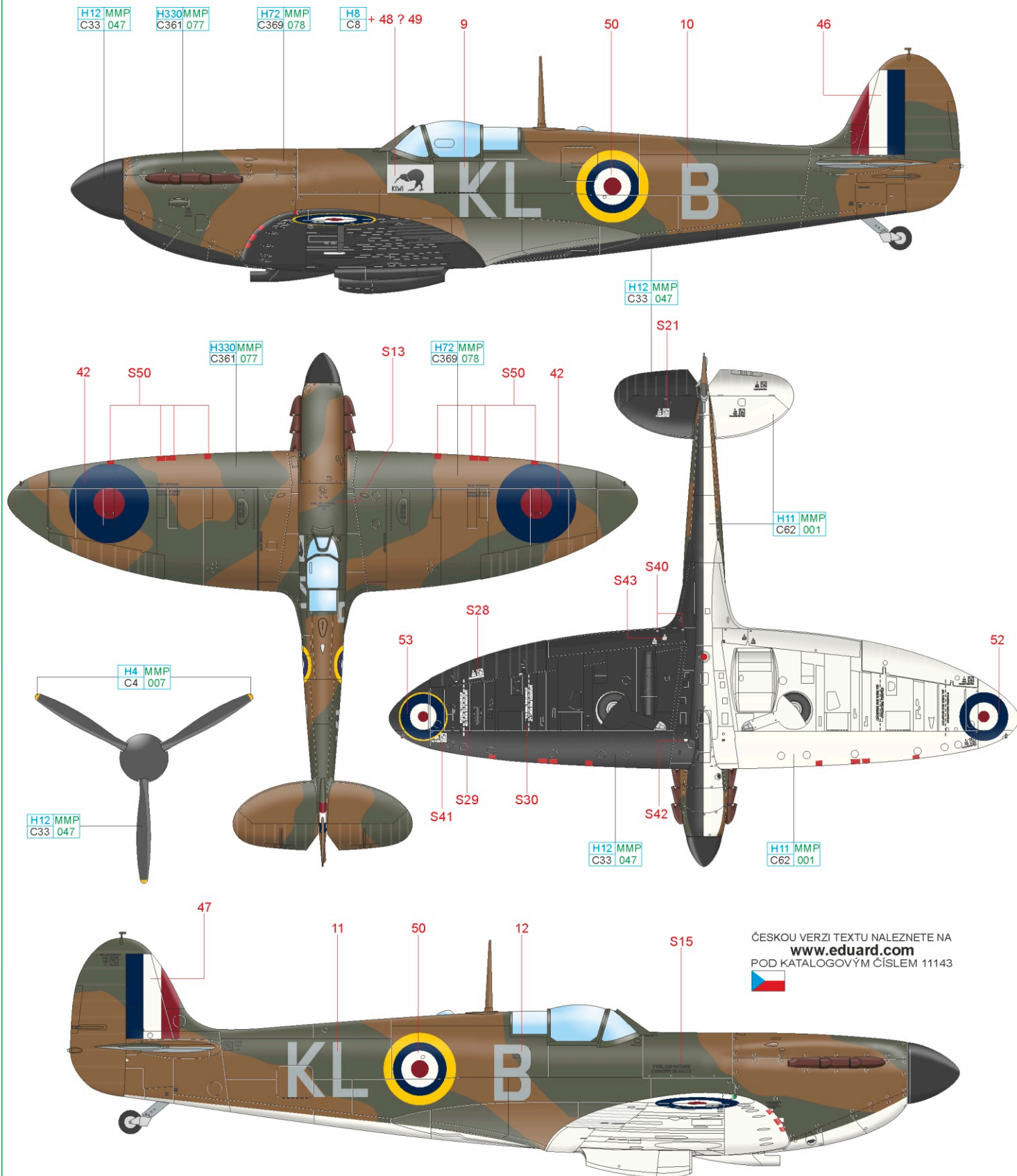

SILVER	H8 C8	WHITE	H11 MMP C62 001	YELLOW	H4 MMP C4 007	DARK EARTH	H72 MMP C369 078	DARK GREEN	H330 MMP C361 077	BLACK	H12 MMP C33 047
--------	-------	-------	-----------------	--------	---------------	------------	------------------	------------	-------------------	-------	-----------------

# F P9443, flown by F/Lt Douglas Bader, No. 222 Squadron, RAF Duxford, Cambridgeshire / Kirton in Lindsey, Lincolnshire, early June 1940

Legendary Douglas Bader lost both his legs after an aerobatics accident with Bristol Bulldog Mk.II on the December 14th, 1931. He returned to RAF in January 1940, while served with No. 19 Squadron and then from May 1940 with No. 222 Squadron. He claimed his first Bf 109 during operation Dynamo. He was named the Squadron Leader of No. 242 Squadron, equipped with Hurricane Mk.IIs on June 28th, 1940. He was a supporter of Big Wing tactics. Bader accomplished 11 confirmed kills during the BoB. On the March 18th, 1941 he became CO of Tangmere Wing, flying the offensive sweeps over France. He was shot down in Spitfire Mk.Va (signed DB, code name Dogsbody) near Saint Omer and captured on September 9th, 1941. He lost his prosthetic leg due the bail out, the delivery of a replacement by RAF Blenheim was managed by A.Galland. Bader was, despite his escape attempts, until April 1945 imprisoned in Oflag IV-C in the Colditz castle. After retiring from RAF in 1946, he worked for Shell company. As a Member of Parliament, he was infamous for his controversial opinions. He died after fatal heart attack on September 5th, 1982, after a dinner to honor of A/M A.Harris.

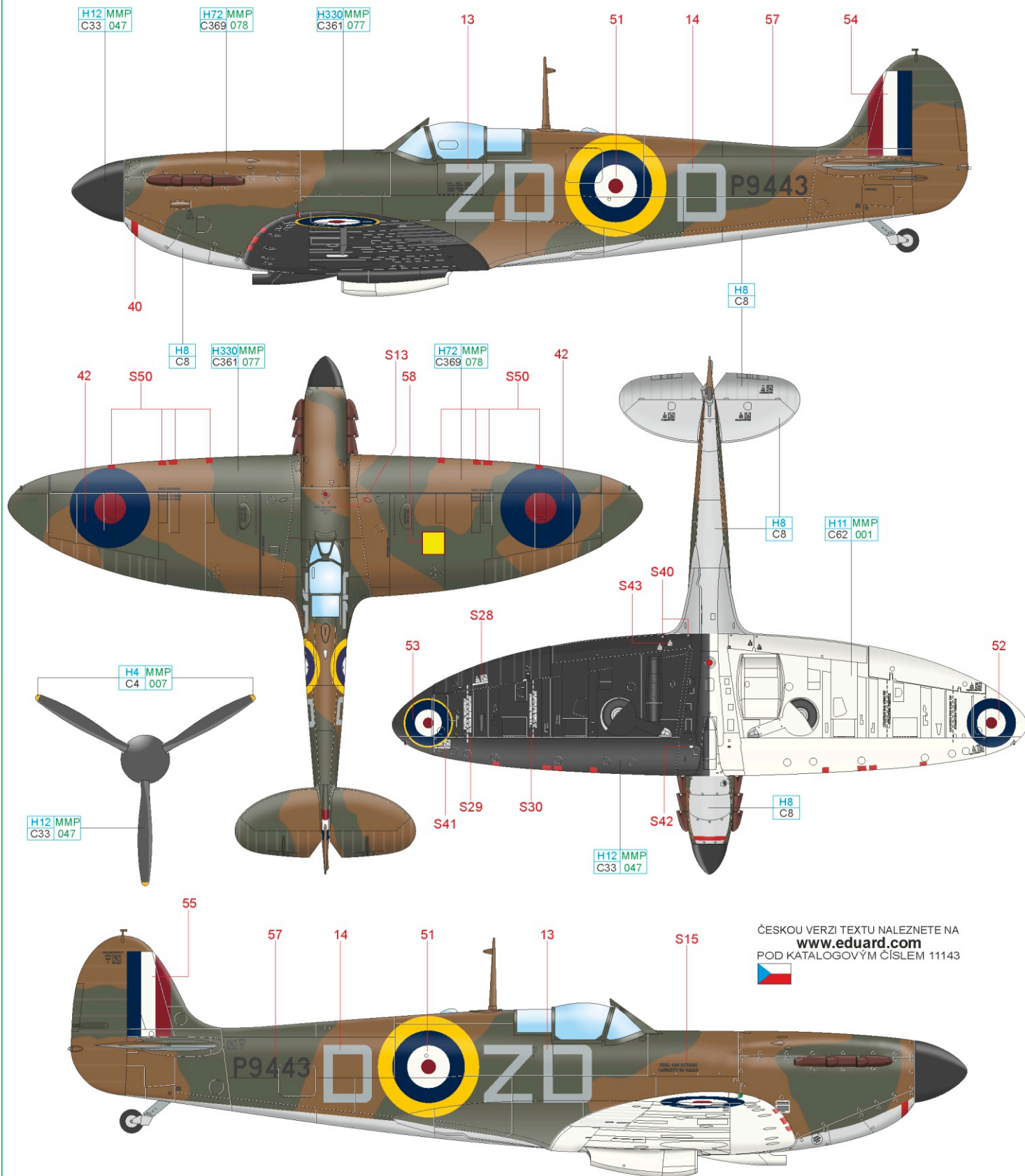

ČESKOU VERZI TEXTU NALEZNETE NA  
[www.eduard.com](http://www.eduard.com)  
 POD KATALOGOVÝM ČÍSLEM 11143



SILVER	H8 C8	WHITE	H11 MMP C62 001	YELLOW	H4 MMP C4 007	DARK EARTH	H72 MMP C369 078	DARK GREEN	H330 MMP C361 077	BLACK	H12 MMP C33 047
--------	----------	-------	--------------------	--------	------------------	------------	---------------------	------------	----------------------	-------	--------------------

**G K9953, flown by F/Lt. Adolph Gysbert Malan, No. 74 Squadron, RAF Hornchurch, Essex, June/July 1940**

No. 74 Squadron reinforced their Spitfires in February 1939. A South African Adolf "Sailor" Malan, whose original job was truly a sailor, entered the war on September 6th, 1940, through infamous Battle of Barking Creek incident, where his A Flight accidentally shot down two Hurricanes of No. 56 Squadron. During operation Dynamo accumulated 5 confirmed kills and in the night from 19th to 20th of June managed to destroy two He 111. Malan was opposed of line-astern formation proposing more flexible finger-four formation. Legend says that he damaged the plane of Werner Molders and even injured him on July 28th. On August 8th, he became S/Ldr of No. 75 Squadron, which achieved 38 kills during four sorties led by Malan on August 11th, 1940. That event is known as "Malan's 11th of August". Malan had 16 confirmed kills in the BoB. Until the end of his career in 1941 he accumulated 27 confirmed kills and 7 shared kills. He was an amazing tactician, and famous with his Ten rules of air combat. After his retirement in 1946 he became a farmer in South Africa. He was politically active as an opponent of apartheid. He died on September 17th, 1963 at the age of 53.

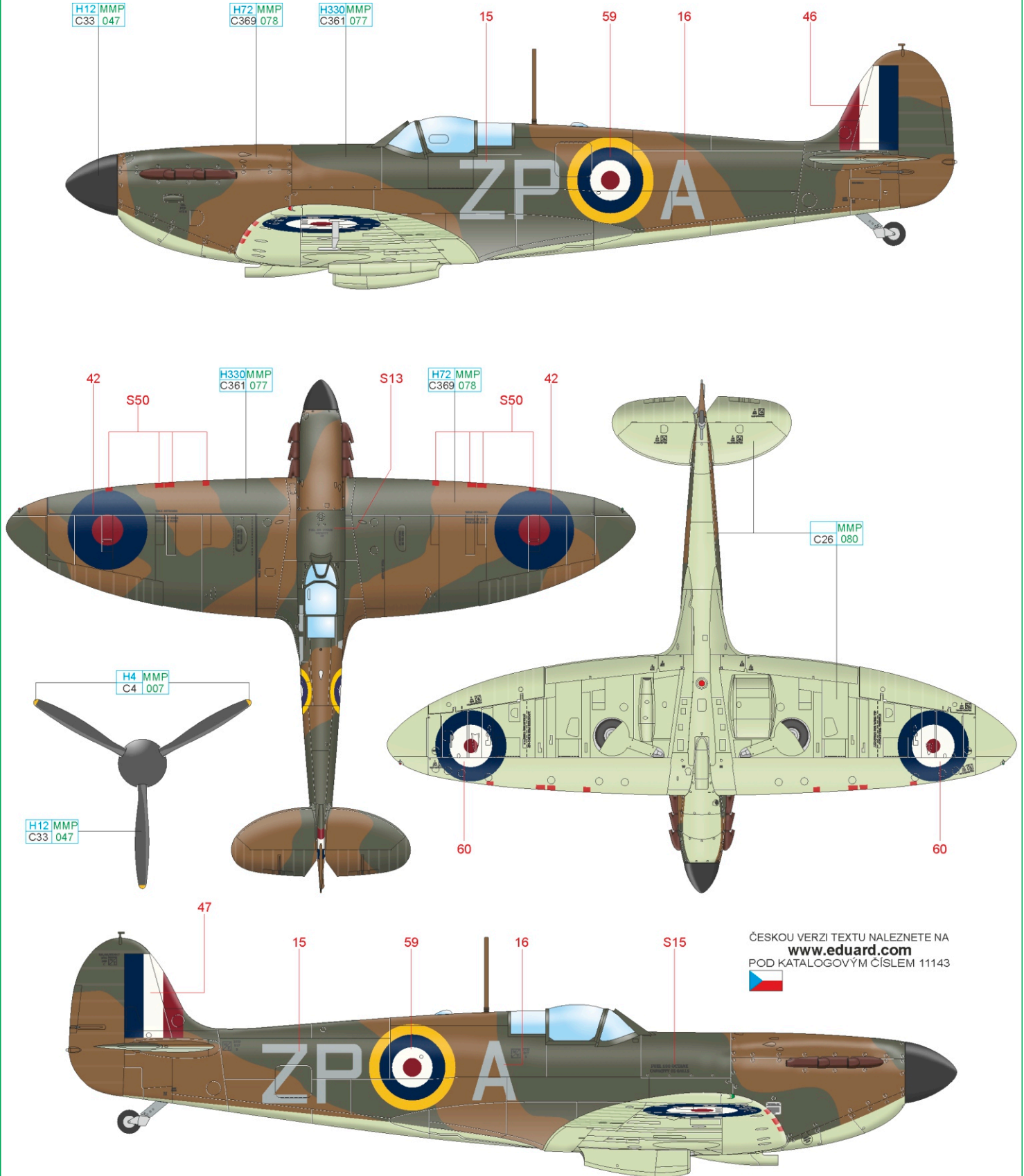

ČESKOU VERZI TEXTU NALEZNETE NA  
[www.eduard.com](http://www.eduard.com)  
 POD KATALOGOVÝM ČÍSLEM 11143



DUCK EGG GREEN MMP C26 080 YELLOW H4 MMP C4 007 DARK EARTH H72 MMP C369 078 DARK GREEN H330MMP C361 077 BLACK H12 MMP C33 047

# H N3162, flown by P/O Eric Stanley Lock, No. 41 Squadron, RAF Hornchurch, Essex, United Kingdom, August/September 1940

Eric Lock entered No. 41 Squadron as a rookie in June 1940 and on August 15th got the first of his 21 kills in the Battle of Britain, which made him the most successful Allied fighter ace of the Battle. On November 17th, 1940, he was seriously injured on his right arm and both legs by the Bf 109E fire. During following three months he underwent 15 difficult surgeries and spent next three months in a rehabilitation center in Royal Masonic Hospital, in care of famous pioneer of the plastic surgery Archibald McIndoe who helped him to recover. He came back to No. 41 Squadron in June 1941 and was promoted to Flight Lieutenant in July became the leader of B Flight of No. 611 Squadron. On August 3rd, 1941, after returning from a Rhubarb type action, he attacked a German column near Pas de Calais as has been MIA ever since. He was probably shot down by anti-aircraft fire and crashed into the sea. Neither him nor his Spitfire was ever found. At the time of his disappearance he was credited with 26 confirmed kills achieved during 25 weeks of his combat duty throughout one year and with 6 months spent in hospitals.

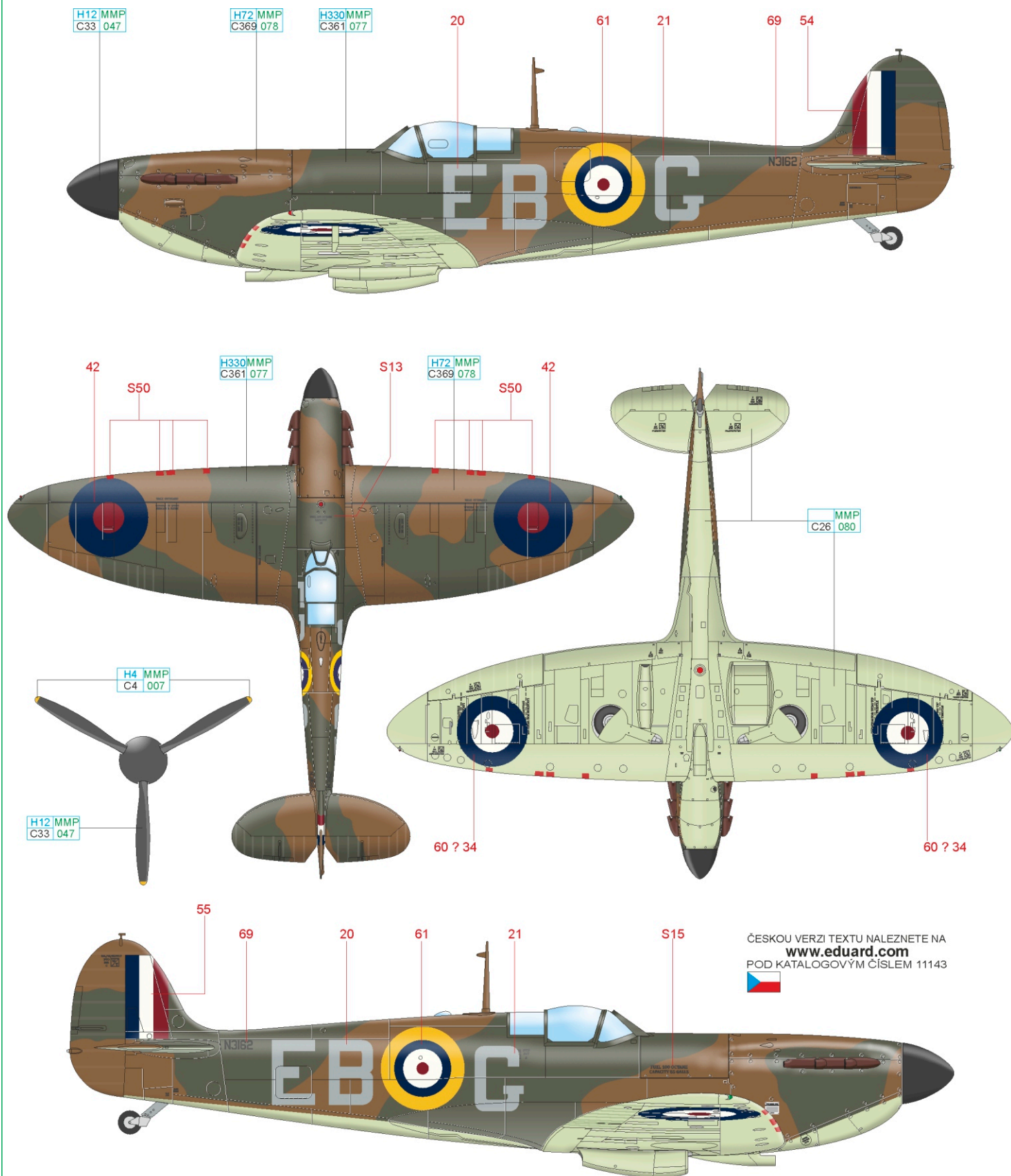

ČESKOU VERZI TEXTU NALEZNETE NA  
[www.eduard.com](http://www.eduard.com)  
 POD KATALOGOVÝM ČÍSLEM 11143



DUCK EGG GREEN	MMP C26 080	YELLOW	H4 MMP C4 007	DARK EARTH	H72 MMP C369 078	DARK GREEN	H330MMP C361 077	BLACK	H12 MMP C33 047
----------------	-------------	--------	---------------	------------	------------------	------------	------------------	-------	-----------------



# X4425, flown by F/Sgt. George Cecil Unwin, No. 19 Squadron, RAF Fowlmere, Cambridgeshire, August/September 1940

This aircraft is depicted in the final fashion of Spitfires in the Battle of Britain times, including the back mirror and full armor. The pilot, George Unwin, nicknamed Grumpy, was one of the most experienced flyers of the No. 19 Squadron. He was one of the first Spitfire pilots he took to the skies in the new K9792 already on August 16th, 1938, more than a year before the war. During the early tests in fall of 1938 he tested 15 new Spitfires. He crashed a K9797 after an engine failure and landed outside of Acton village in Suffolk to prevent potential life losses in the agglomeration. During the operation Dynamo he was credited with 3 confirmed kills, Hs 126, Bf 110 and He 111. During the Battle of Britain he added another 11 kills to his tally. At the end of the 1940 he left the operational service and served as an instructor in various training units until October 1943. He got back to fighting in April 1944, when he flew Mosquitos with No. 613 Squadron as a part of 2nd TAF and at the end of 1944 went back to the job as an instructor. Between the years 1948-52 he flew with Bristol Brigand to participate in the fights against the communist insurgents in Malaysia 1952. He retired from the RAF in rank of Wing Commander in 1961. He died on June 28th, 2006 at the age of 93.

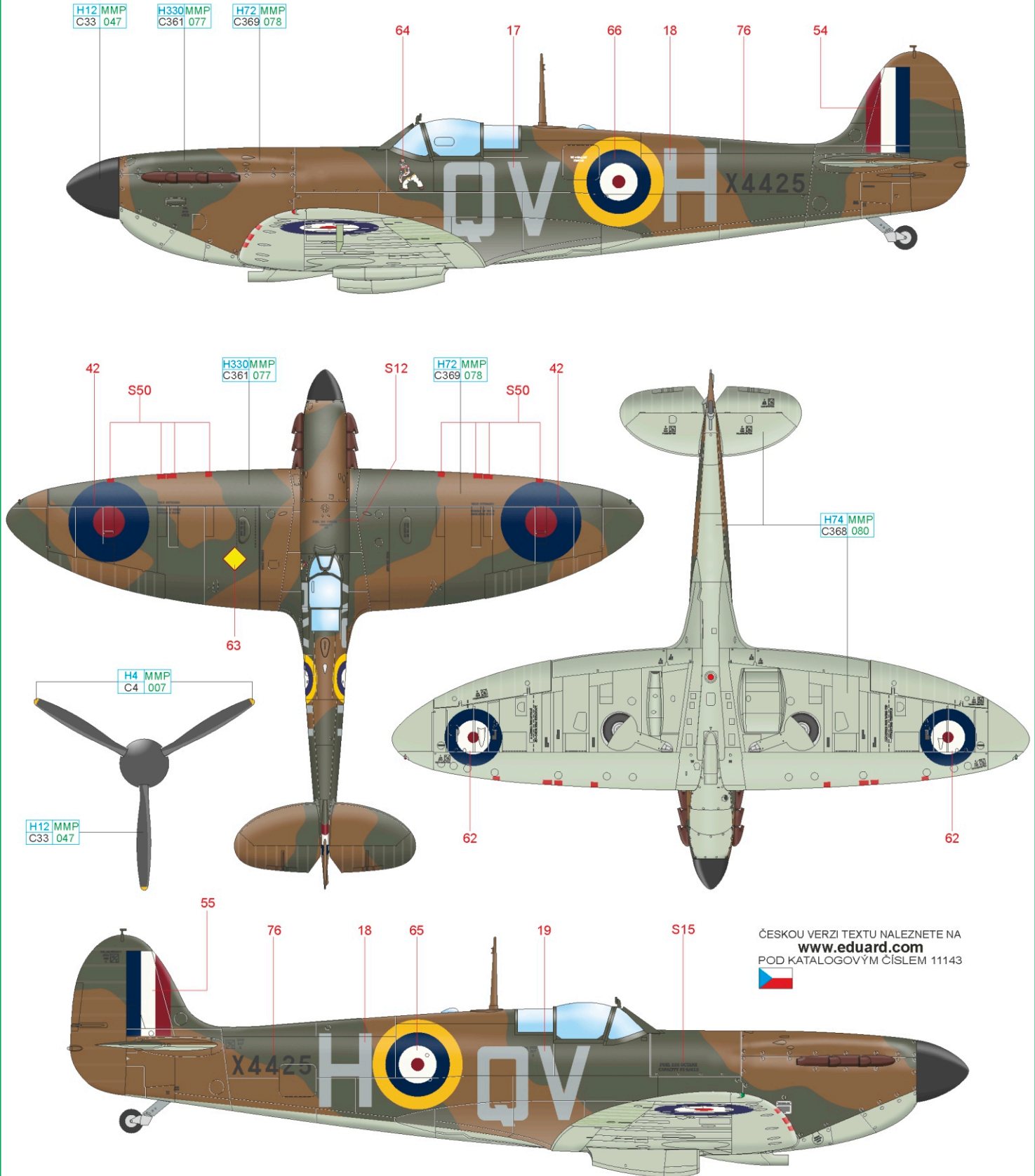

ČESKOU VERZI TEXTU NALEZNETE NA  
[www.eduard.com](http://www.eduard.com)  
 POD KATALOGOVÝM ČÍSLEM 11143



- |     |                     |        |                  |            |                     |            |                      |       |                    |
|-----|---------------------|--------|------------------|------------|---------------------|------------|----------------------|-------|--------------------|
| SKY | H74 MMP<br>C368 080 | YELLOW | H4 MMP<br>C4 007 | DARK EARTH | H72 MMP<br>C369 078 | DARK GREEN | H330 MMP<br>C361 077 | BLACK | H12 MMP<br>C33 047 |
|-----|---------------------|--------|------------------|------------|---------------------|------------|----------------------|-------|--------------------|

# J X4382, flown by P/O Osgood Philip Villiers Hanbury, No. 602 Squadron, RAF Westhampnett, West Sussex, September 1940.

Osgood Hanbury, nicknamed Pedro, an Eton College alum, began his combat career in June 1940 as a Lysander pilot. He volunteered to fighters and was reassigned to No. 602 Squadron on September 3rd, 1940. His X4382 is a typical representative of a late fashion of Spitfire Mk.I, probably with De Havilland propeller already converted to be a constant speed propeller, fully armored cockpit and fuel tank, radio TR.1133 without a wire antenna and IFF R.3002 with wire antenna between the fuselage and horizontal stabilizer tips. Hanbury achieved 4 confirmed kills until end of the year. He received DFC for defense of Tobruk in May 1942. On June 23rd, 1942 he was appointed a squadron leader role of No. 260 Squadron. He got married to Patricia Cecil Harman on the 22nd of May 1943. He died eleven days after when he was returning to Africa as a passenger onboard a Lockheed Hudson of No. 117 Squadron, flown by S/Ldr Robert Yaxley. Their aircraft was shot down by Junkers Ju 88C flown by Hans Olbrecht over the Bay of Biscay.

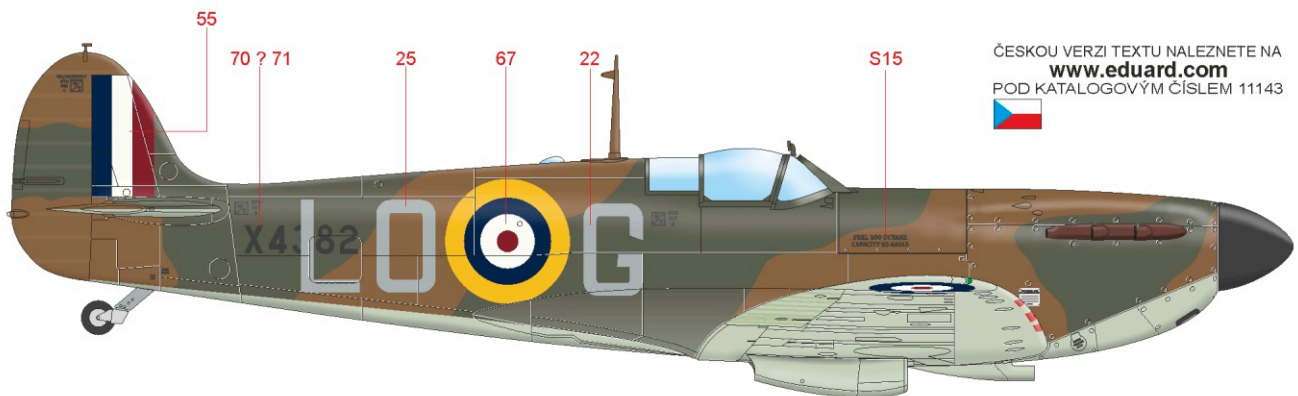
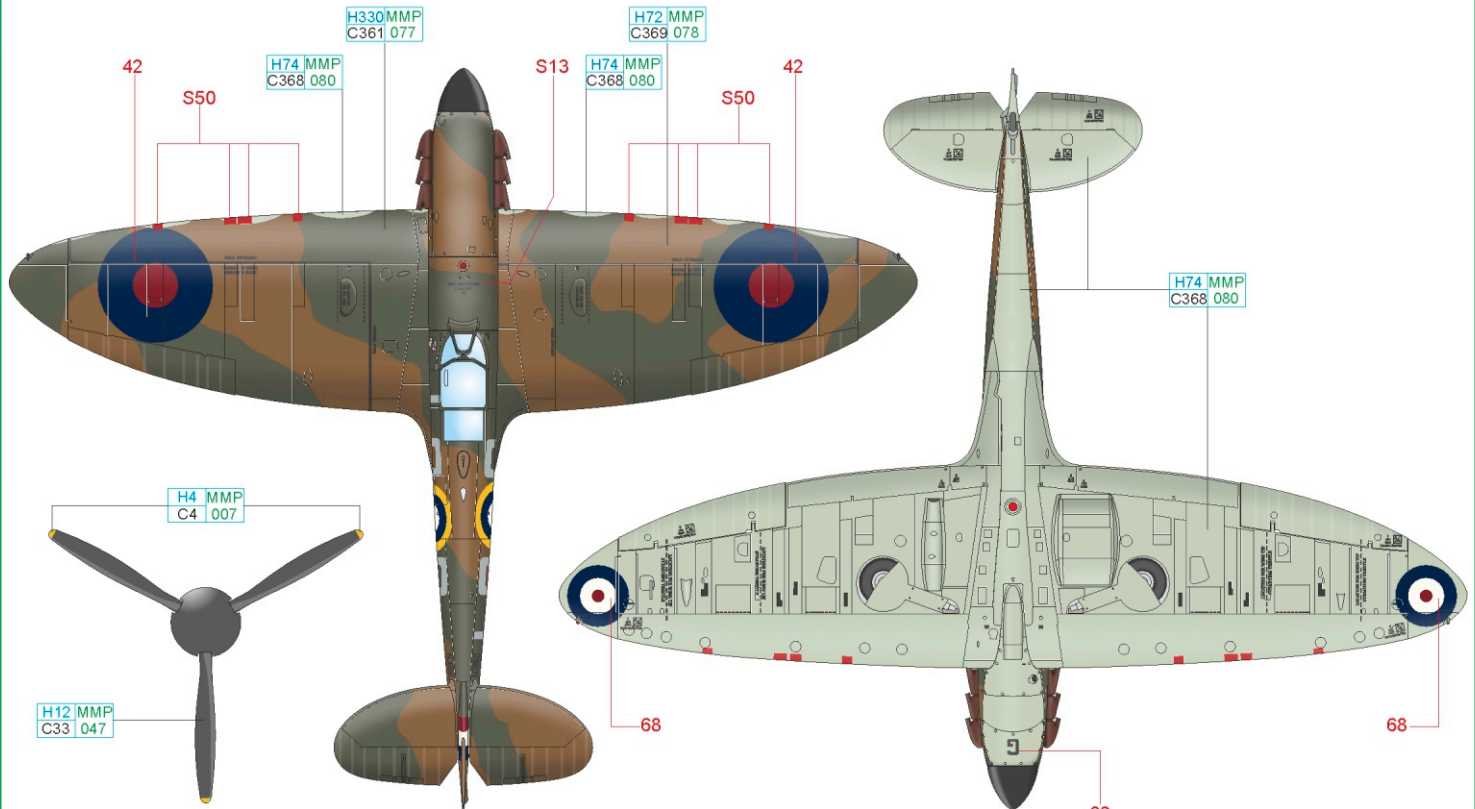
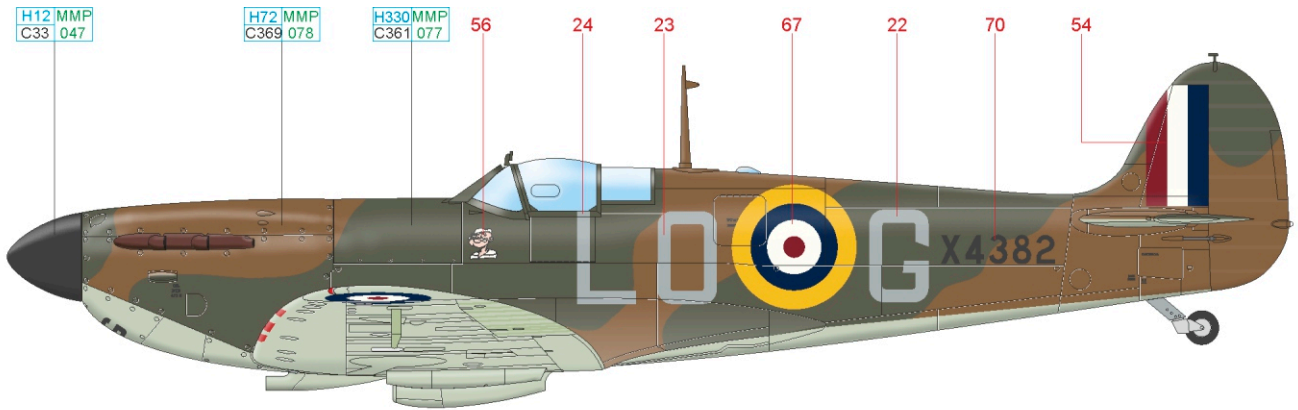

ČESKOU VERZI TEXTU NALEZNETE NA  
[www.eduard.com](http://www.eduard.com)  
 POD KATALOGOVÝM ČÍSLEM 11143



- SKY H74 MMP C368 080
- YELLOW H4 MMP C4 007
- DARK EARTH H72 MMP C369 078
- DARK GREEN H330 MMP C361 077
- BLACK H12 MMP C33 047

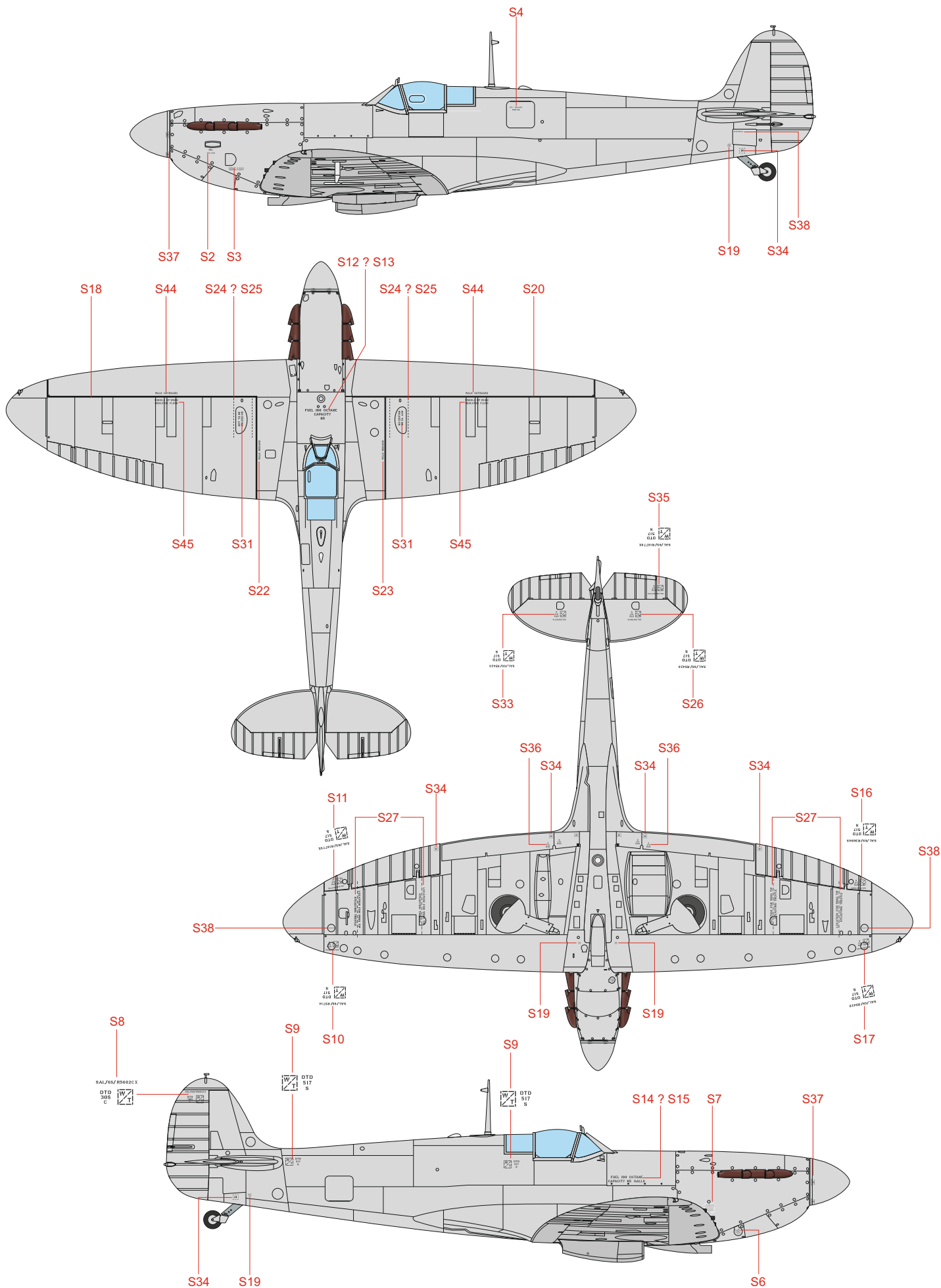

# Eduard goodies for Spitfire Mk.I 1/48

- 481026 Spitfire Mk.I landing flaps 1/48 (PE-Set)
  - FE1102 Spitfire Mk.I seatbelts STEEL 1/48 (PE-Set)
  - 644063 Spitfire Mk.I early LööK 1/48 (Brassin)
  - 644064 Spitfire Mk.I late LööK 1/48 (Brassin)
  - 648578 Spitfire Mk.I cockpit 1/48 (Brassin)
  - 648579 Spitfire Mk.I wheels 1/48 (Brassin)
  - 648580 Spitfire Mk.I exhaust stacks 1/48 (Brassin)
  - 648581 Spitfire Mk.I gun bays 1/48 (Brassin)
  - EX709 Spitfire Mk.I TFace 1/48 (Mask)
  - EX713 Spitfire Mk.I 1/48 (Mask)
  - 648589 Spitfire Mk.I undercarriage legs BRONZE 1/48 (Brassin)
- 09/2020 Release

Cat. No. 644063



Cat. No. 644064



Cat. No. 648579



Cat. No. 648578

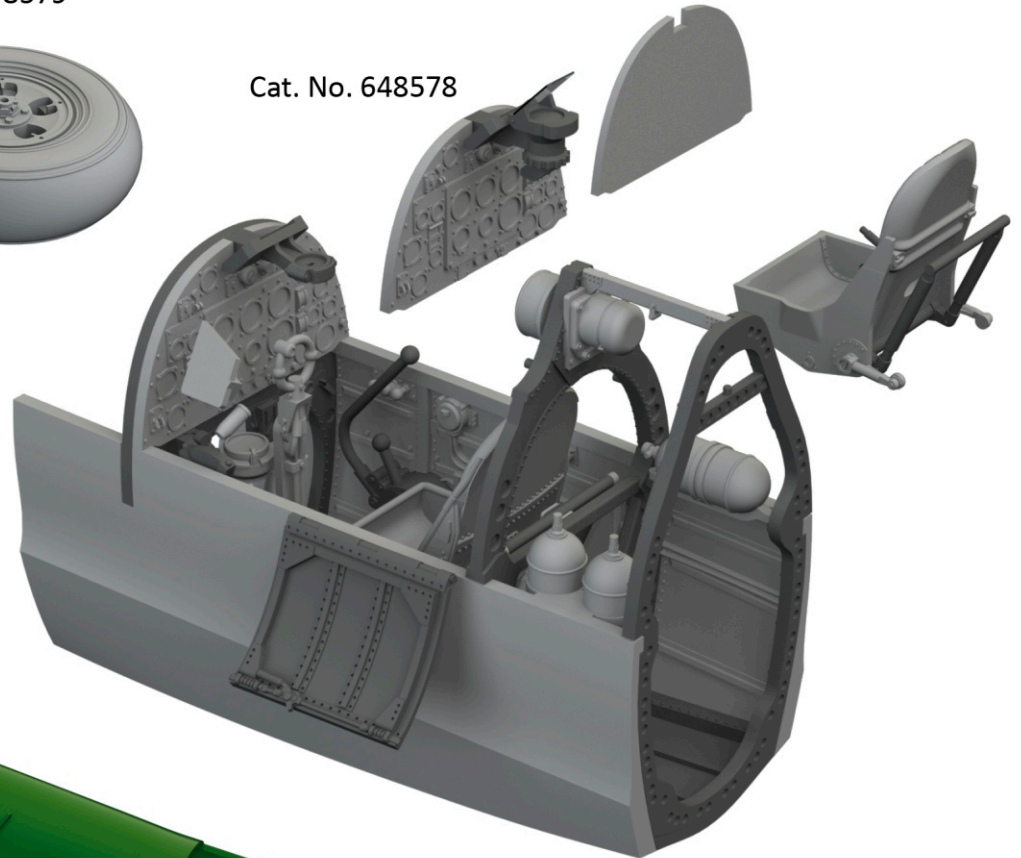

Cat. No. 648581

