

eduard



Ramplstift

INSTRUCTION SHEET

1/48

LIMITED EDITION

11147-NAV1

ATTENTION



UPOZORNĚNÍ



ACHTUNG



ATTENTION



注意



Carefully read instruction sheet before assembling. When you use glue or paint, do not use near open flame and use in well ventilated room. Keep out of reach of small children. Children must not be allowed to suck any part, or pull vinyl bag over the head.



Před započítím stavby si pečlivě prostudujte stavební návod. Při používání barev a lepidel pracujte v dobře větrané místnosti. Lepidla ani barvy nepoužívejte v blízkosti otevřeného ohně. Model není určen malým dětem, mohlo by dojít k požití drobných dílů.

INSTRUCTION SIGNS * INSTR. SYMBOLS * INSTRUKTION SINNBILDEN * SYMBOLES * 記号の説明

OPTIONAL
VOLBABEND
OHNOUTSAND
BROUSITOPEN HOLE
VYVRTAT OTVORSYMETRICAL ASSEMBLY
SYMETRICKÁ MONTÁŽREMOVE
ODŘÍZNOUTREVERSE SIDE
OTOČITAPPLY EDUARD MASK
AND PAINT
POUŽIT EDUARD MASK
NABARVIT

PARTS



DÍLY



TEILE



PIĚCES



部品

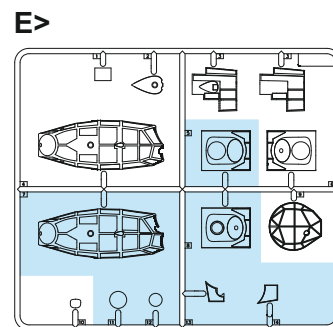
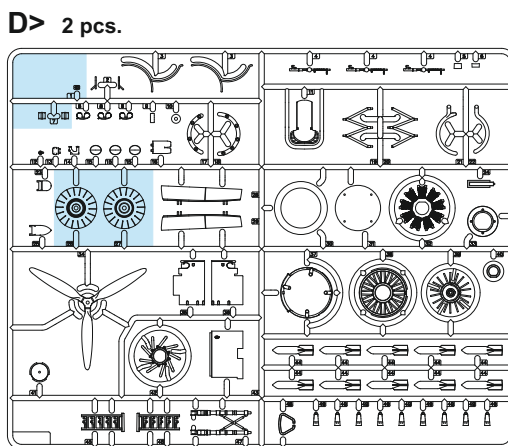
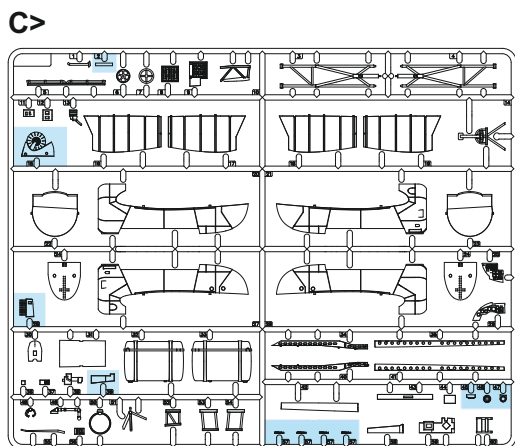
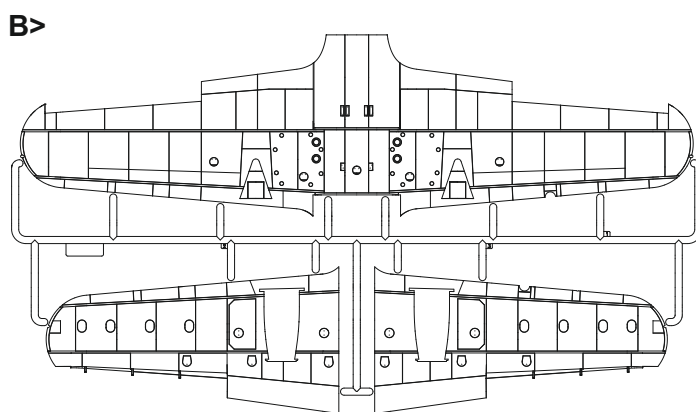
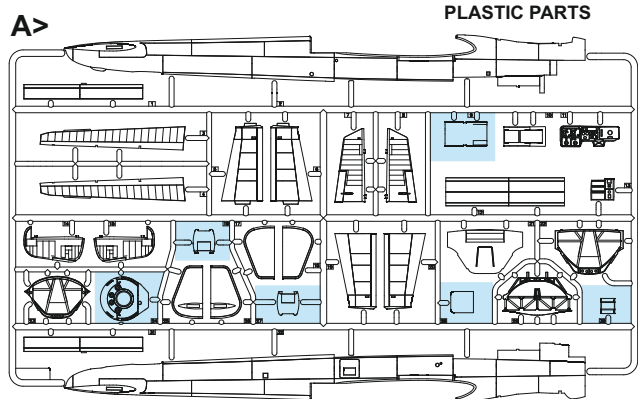

eduard
BRASSIN RP - RESIN PARTS



R7 2 pcs.



R8



R11 2 pcs.



R9



R10

PE - PHOTO ETCHED DETAIL PARTS

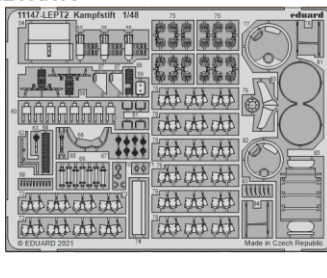
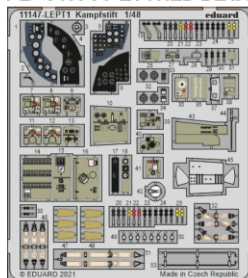
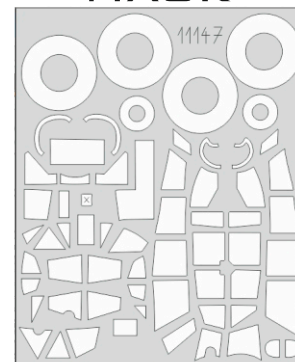
eduard
MASK

-Parts not for use. -Teile werden nicht verwendet. -Pièces à ne pas utiliser. -Tyto díly nepoužívejte při stavbě. - 使用しない部品

COLOURS



BARVY



FARBEN



PEINTURE



色

GSI Creos (GUNZE)		MISSION MODELS	
AQUEOUS	Mr.COLOR	PAINTS	
H2	C2	MMP-047	BLACK
H11	C62	MMP-001	FLAT WHITE
H12	C33	MMP-047	FLAT BLACK
H51	C11	MMP-063	GRAY
H64	C17	MMP-087	RLM71 DARK GREEN
H65	C18	MMP-088	RLM70 BLACK GREEN
H66	C119	MMP-119	RLM79 SAND YELLOW
H67	C115	MMP-057	RLM65 LIGHT BLUE
H70	C60	MMP-056	RLM02 GRAY
H77	C137	MMP-040	TIRE BLACK

GSI Creos (GUNZE)		MISSION MODELS	
AQUEOUS	Mr.COLOR	PAINTS	
H80	C54		KHAKI GREEN
H85	C45		SAIL COLOR
H305	C305	MMP-084	GRAY
H317	C317	MMP-064	GRAY
H413	C113	MMP-090	RLM04 YELLOW
H414	C114	MMP-003	RLM23 RED
H418	C118	MMP-055	RLM78 LIGHT BLUE
Mr.METAL COLOR		METALLICS	
MC214		MMM-001	DARK IRON
MC218		MMM-003	ALUMINIUM

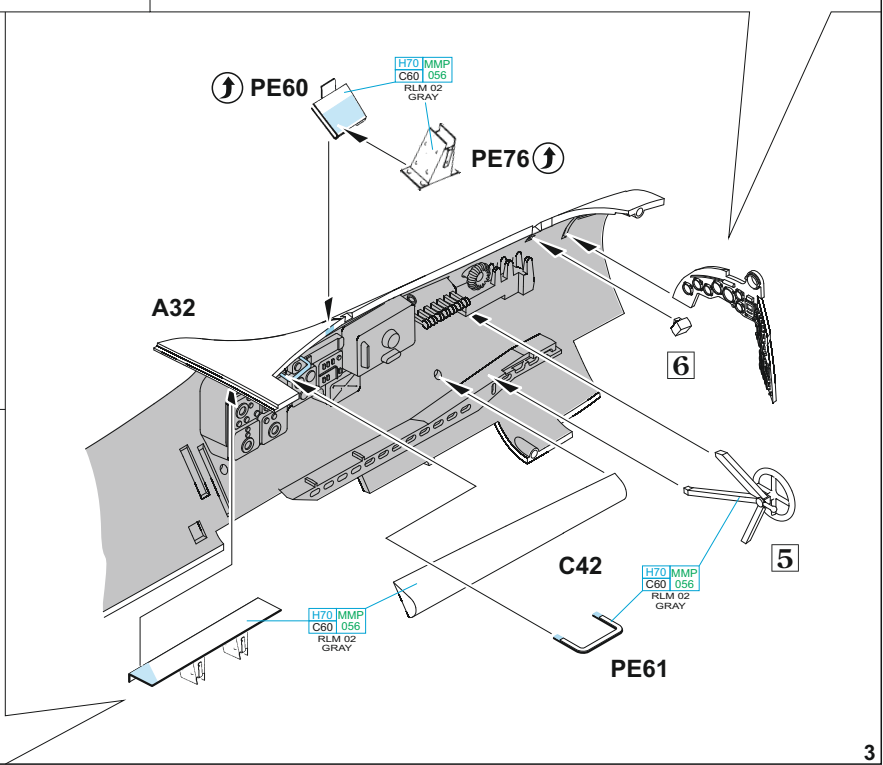
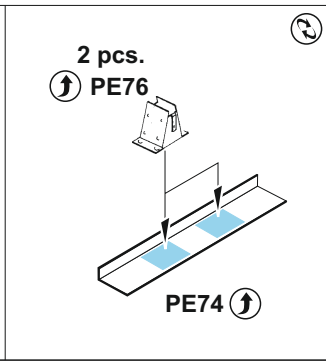
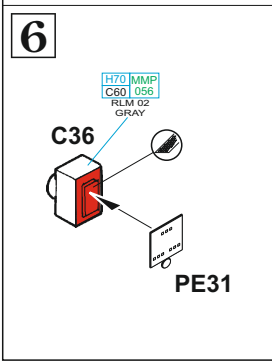
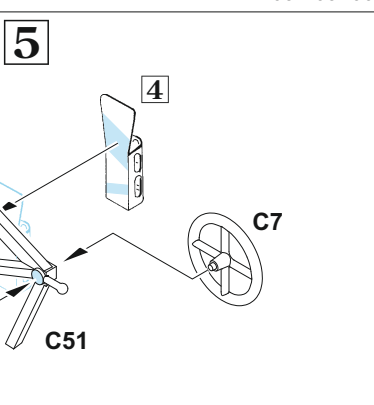
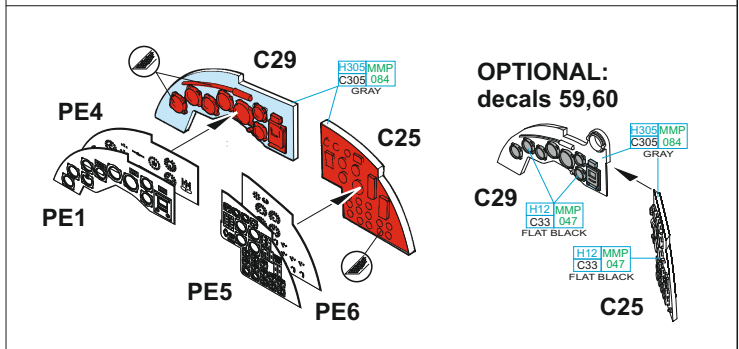
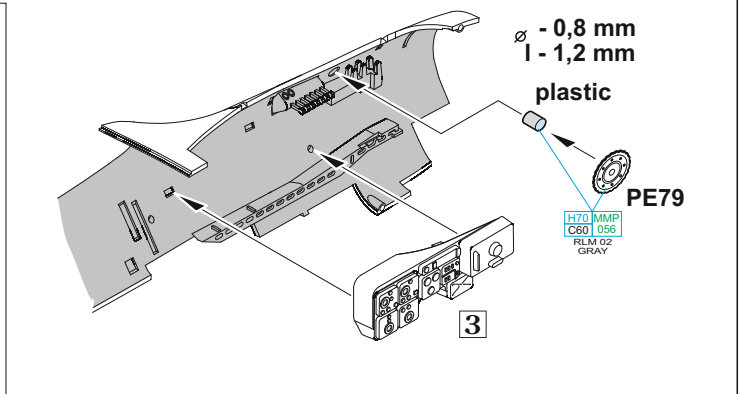
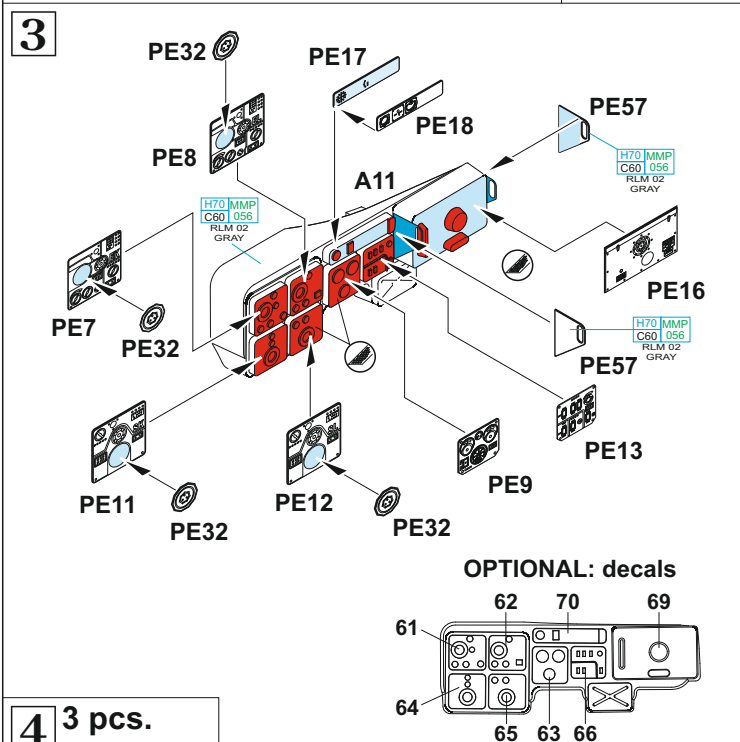
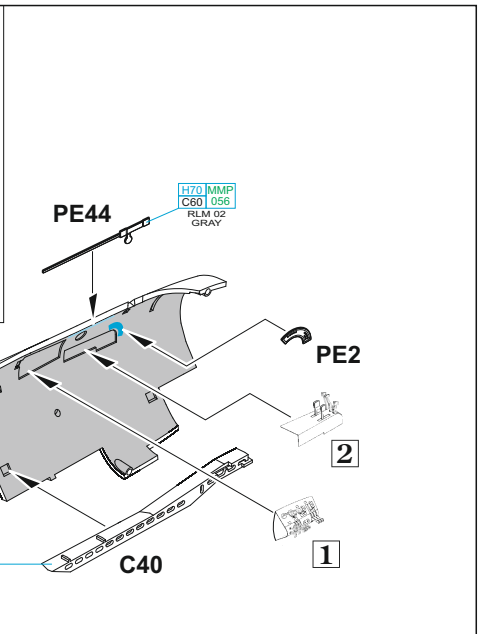
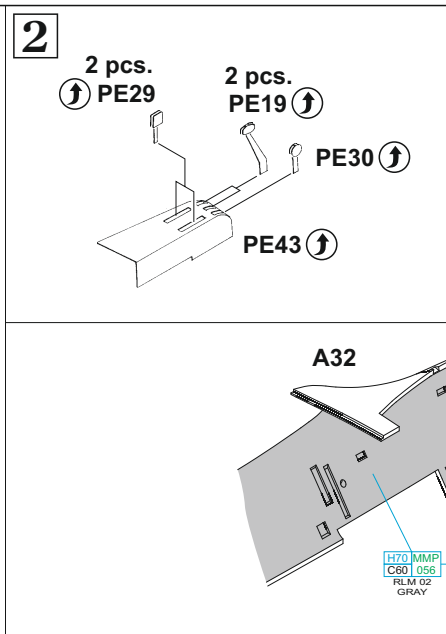
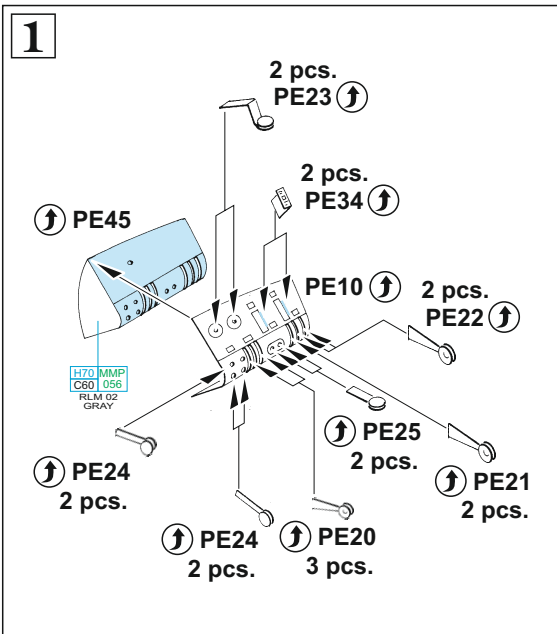

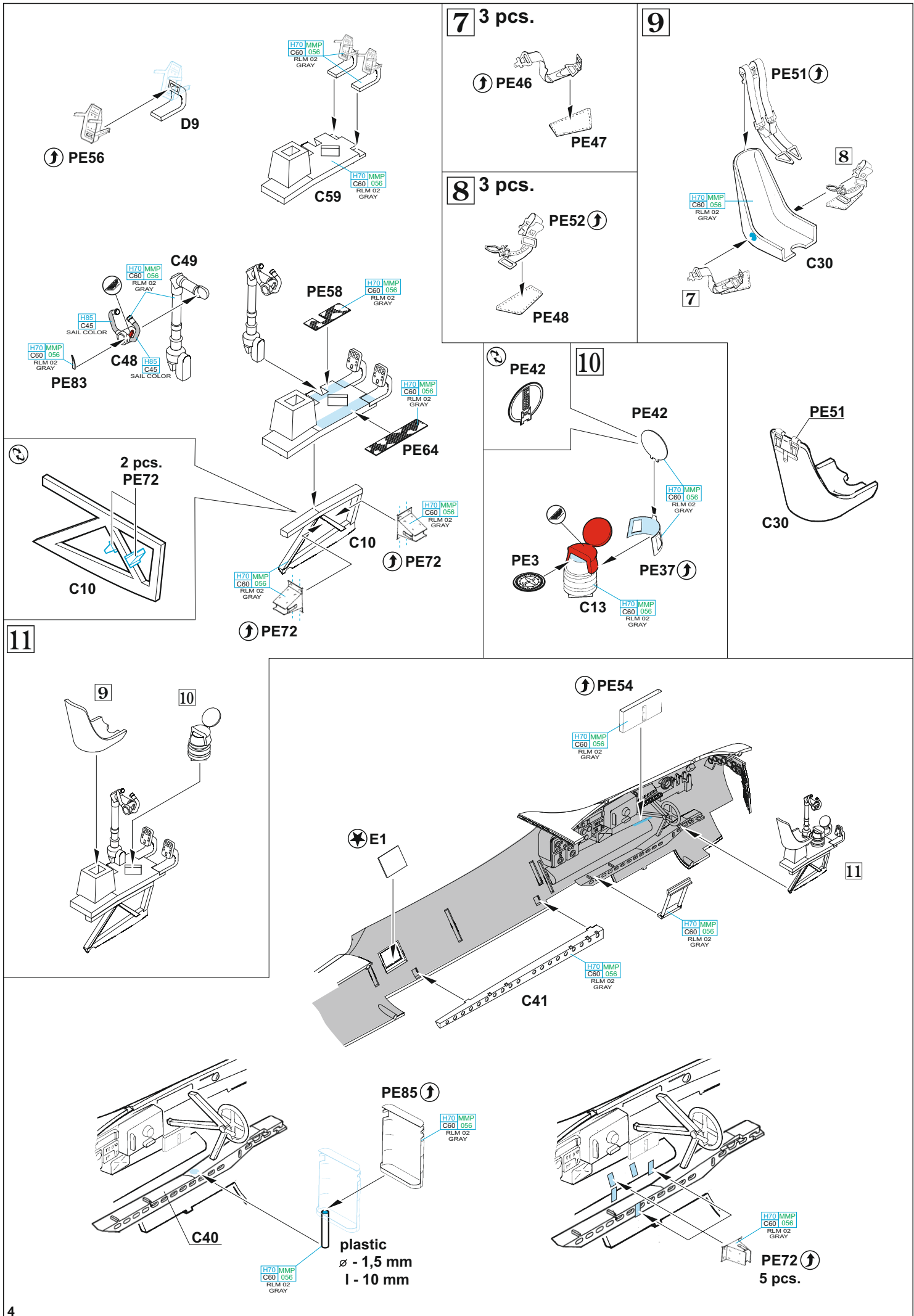

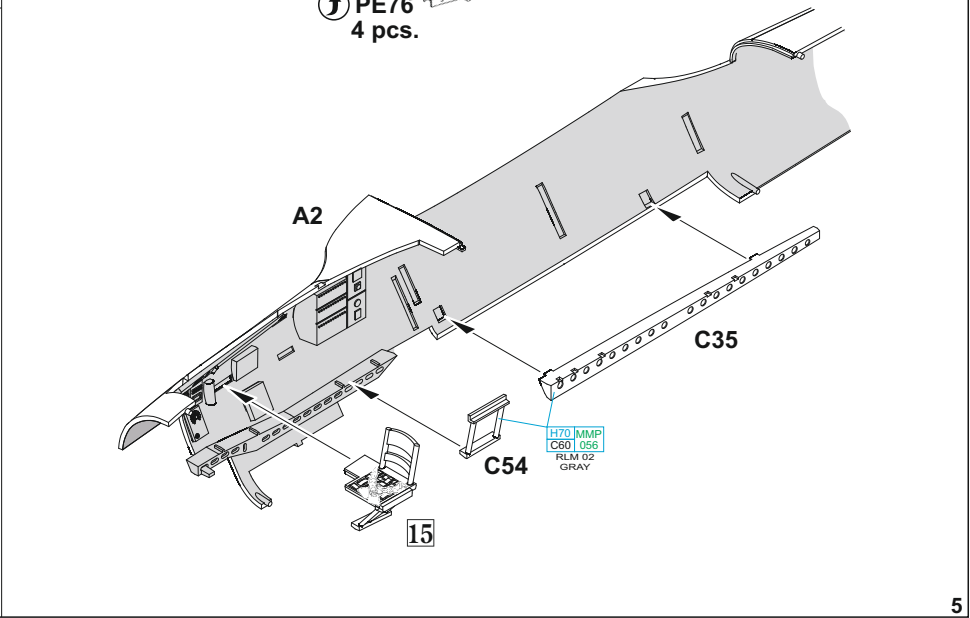
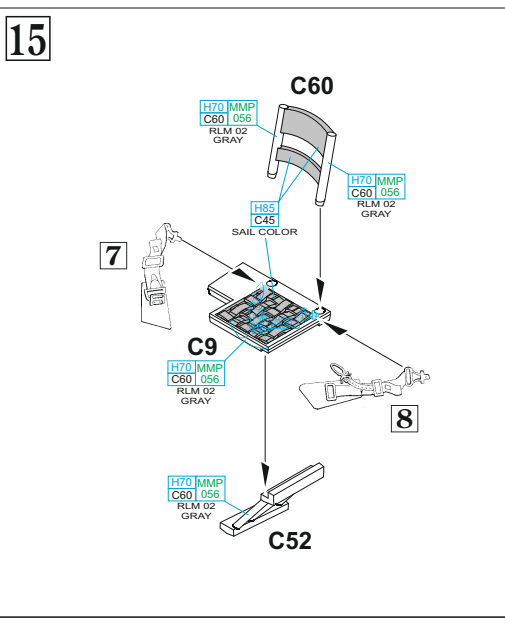
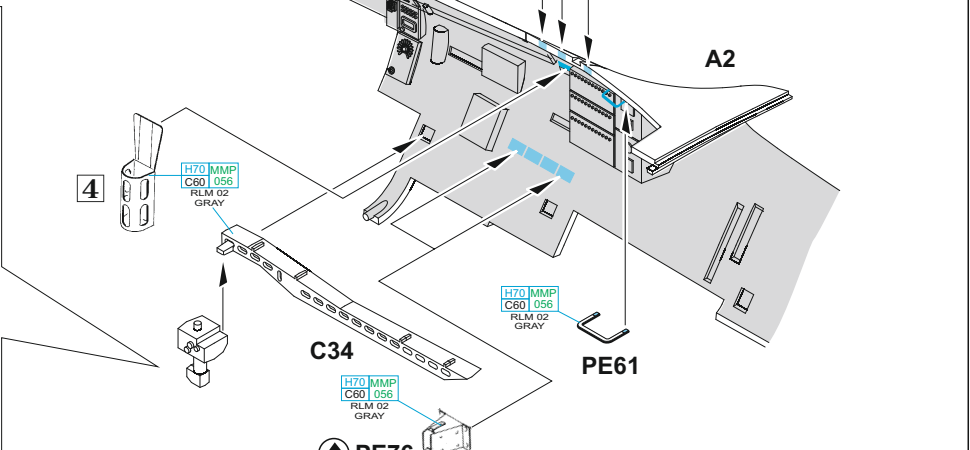
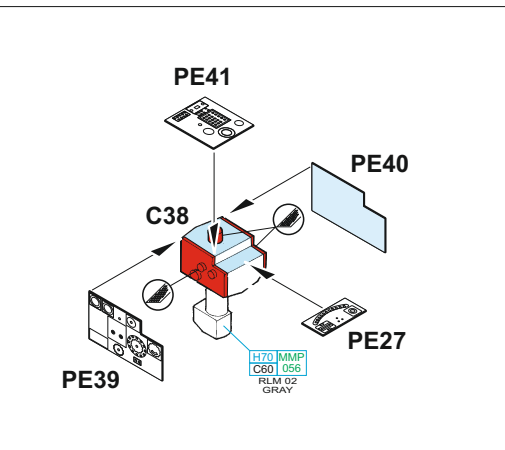
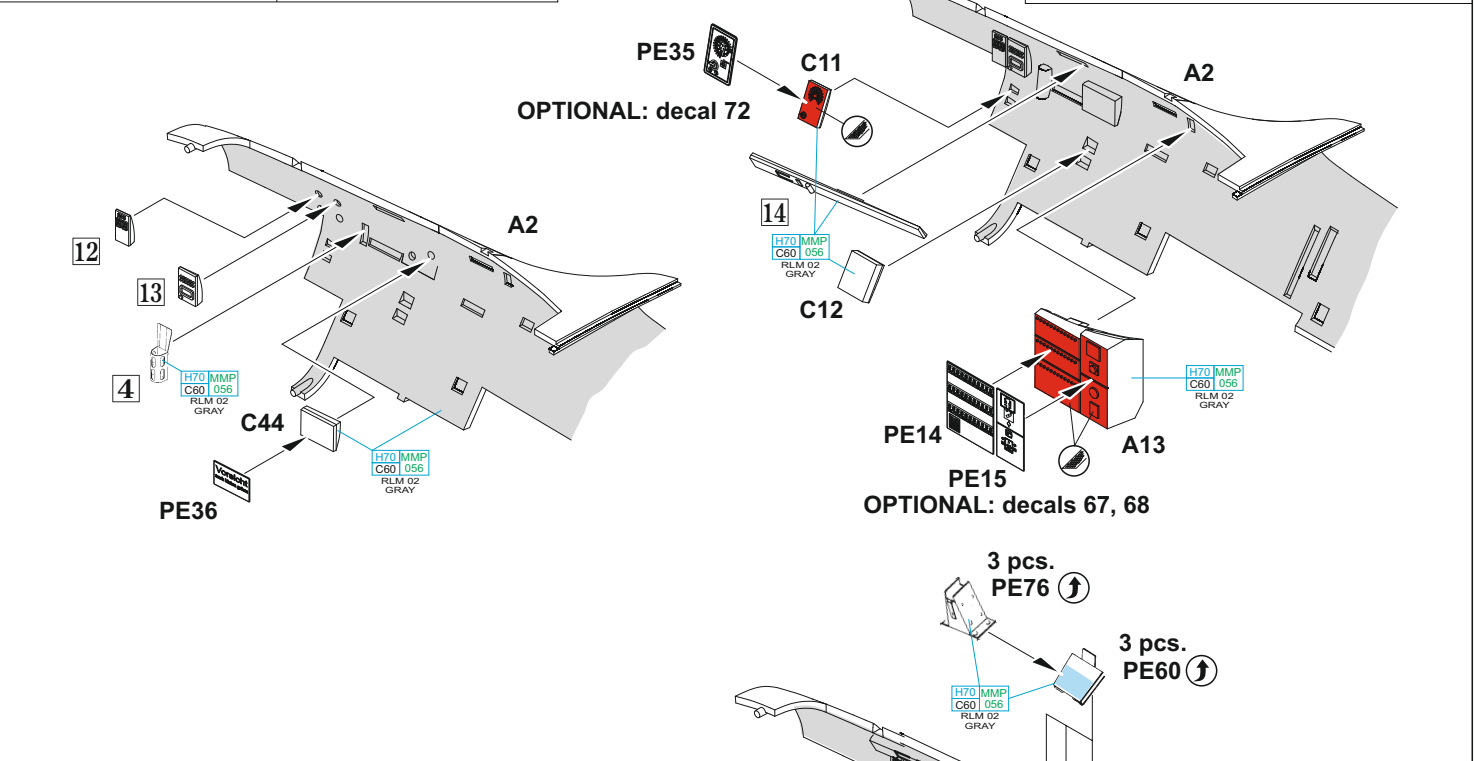
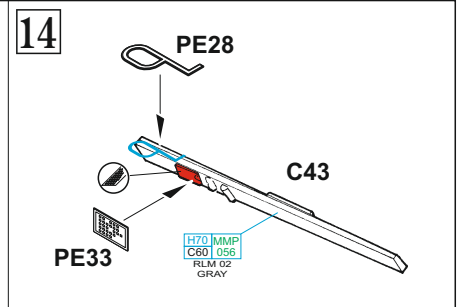
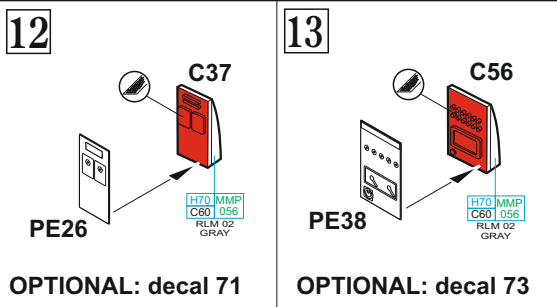

16

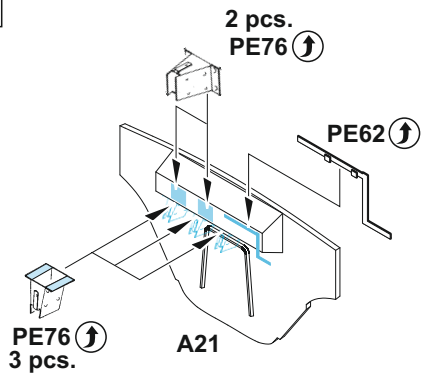

17

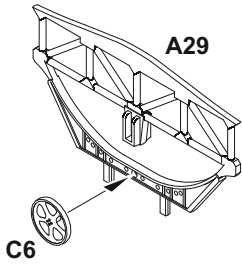

18

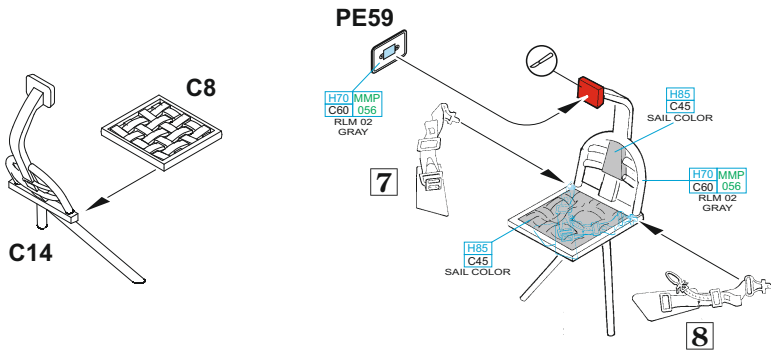

eduard
BRASSIN

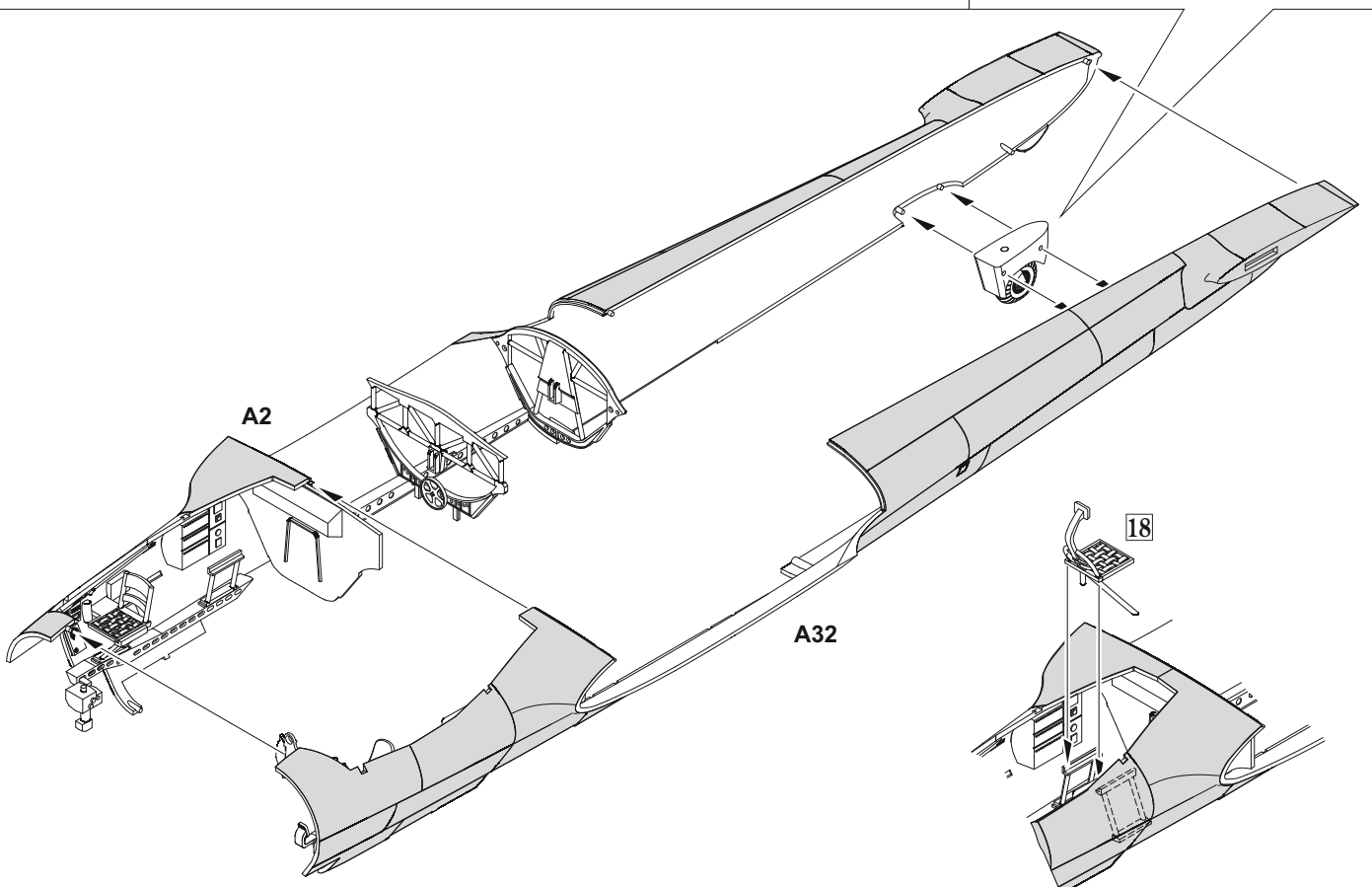
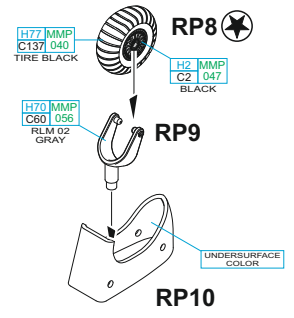

E3
H70 MMP
C60 | 056
RLM 02
GRAY

**SEE YOU
REFERENCES
TO USE
CORRECT PART E3**

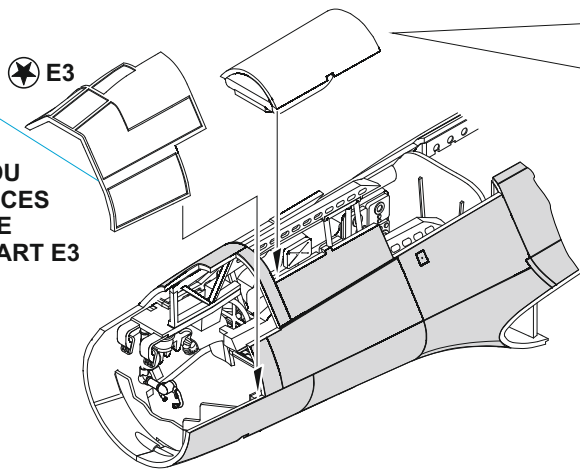

C31

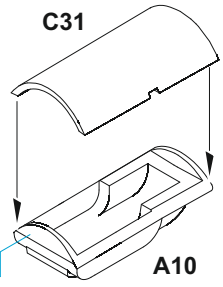

H70 MMP
C60 | 056
RLM 02
GRAY

A10

C33

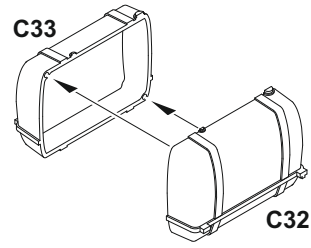

C32

A22

H70 MMP
C60 | 056
RLM 02
GRAY

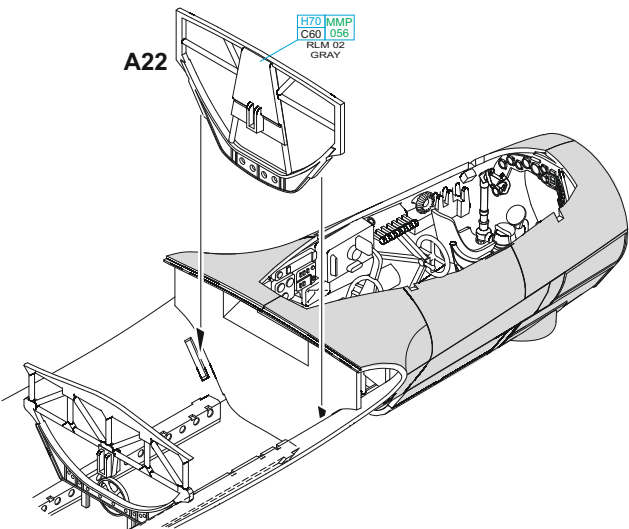

H70 MMP
C60 | 056
RLM 02
GRAY

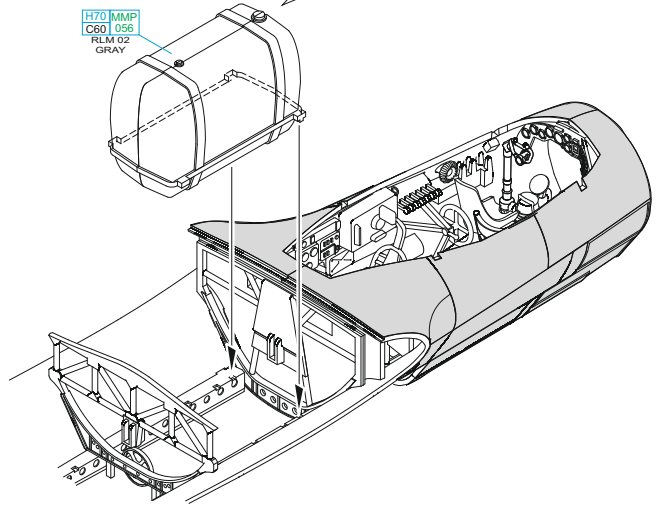

B3

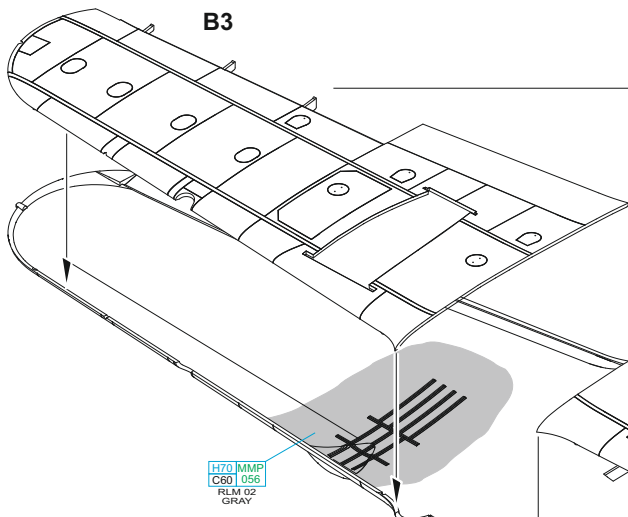

H70 MMP
C60 | 056
RLM 02
GRAY

B2

B1

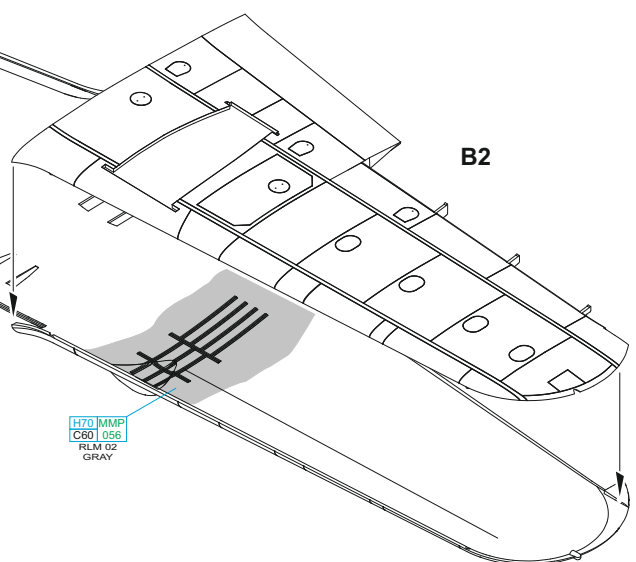

H70 MMP
C60 | 056
RLM 02
GRAY

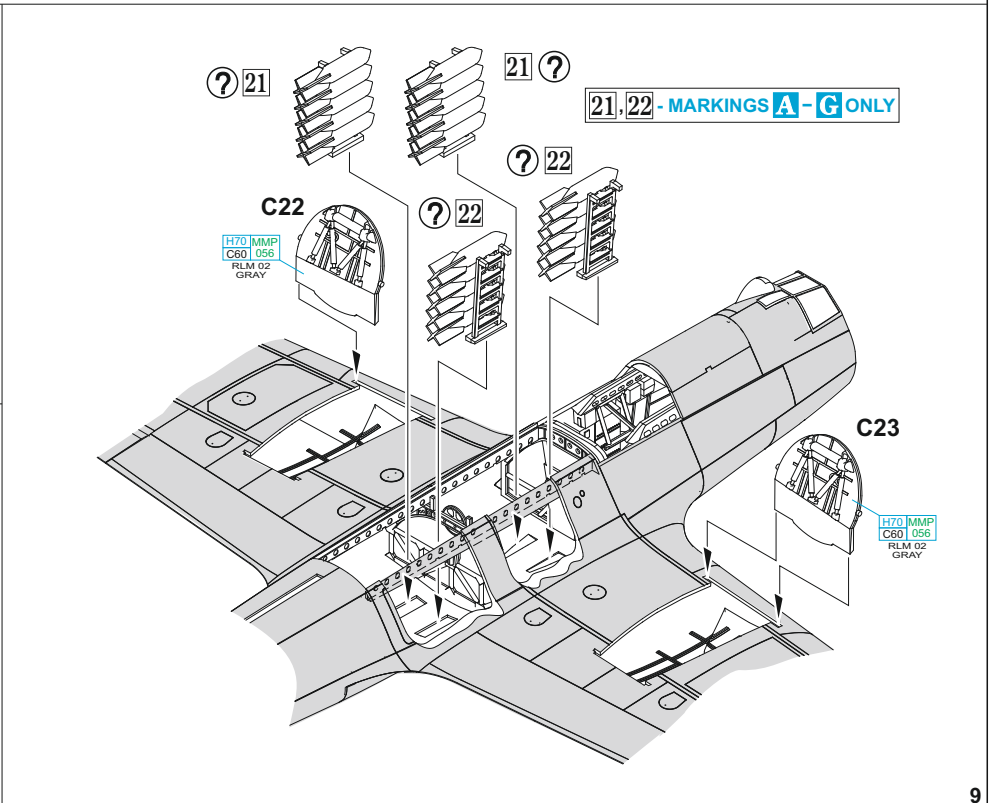
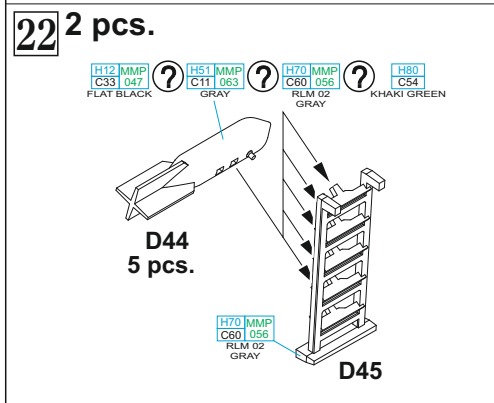
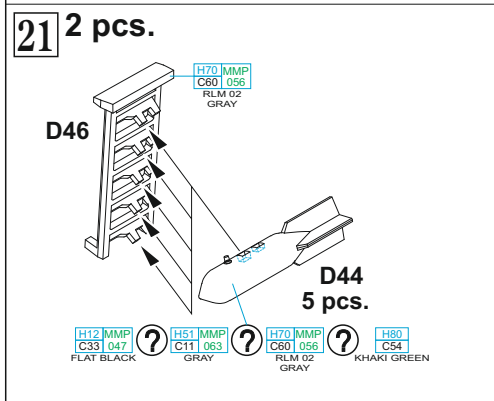
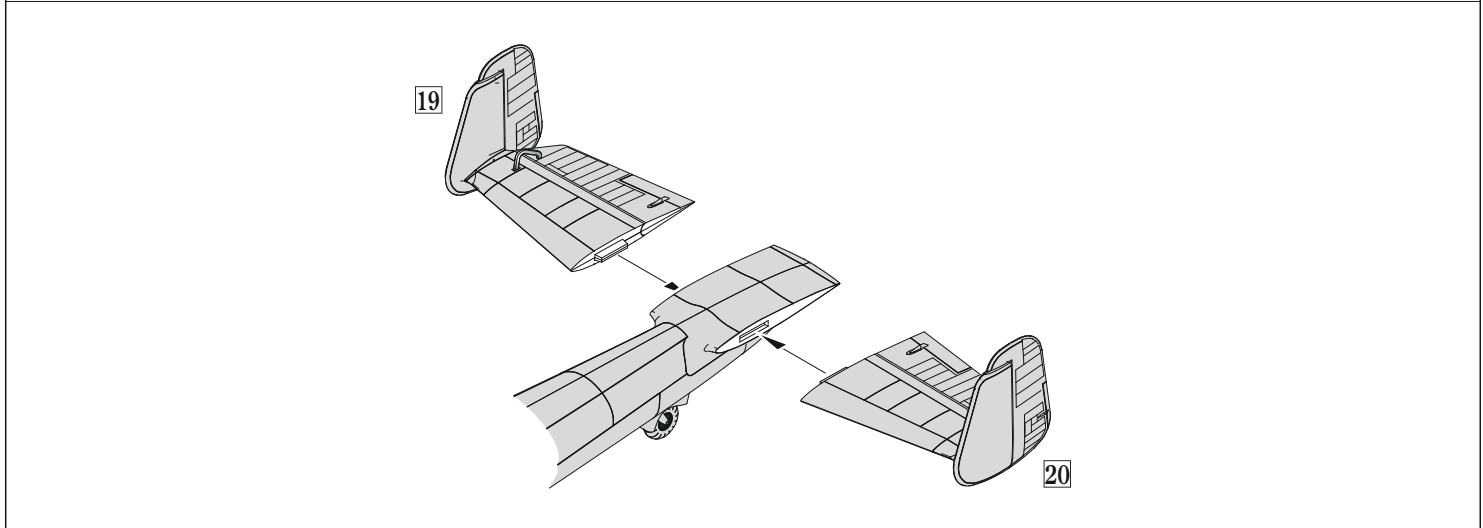
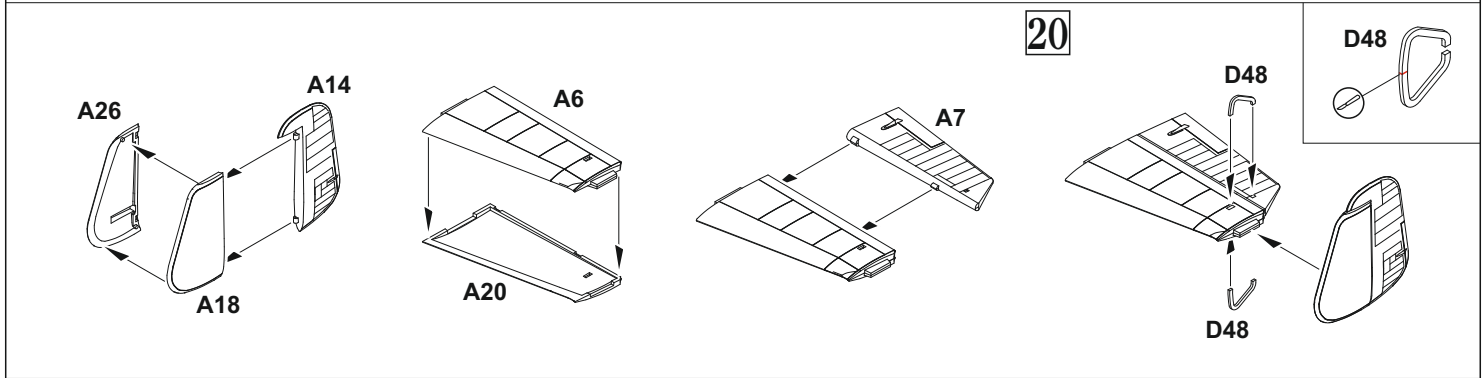
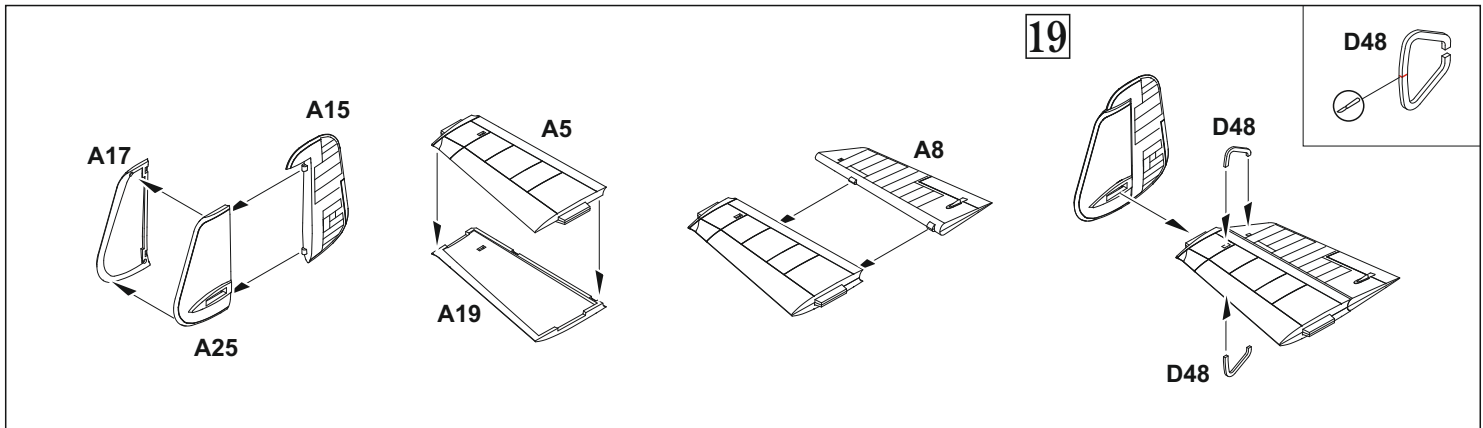

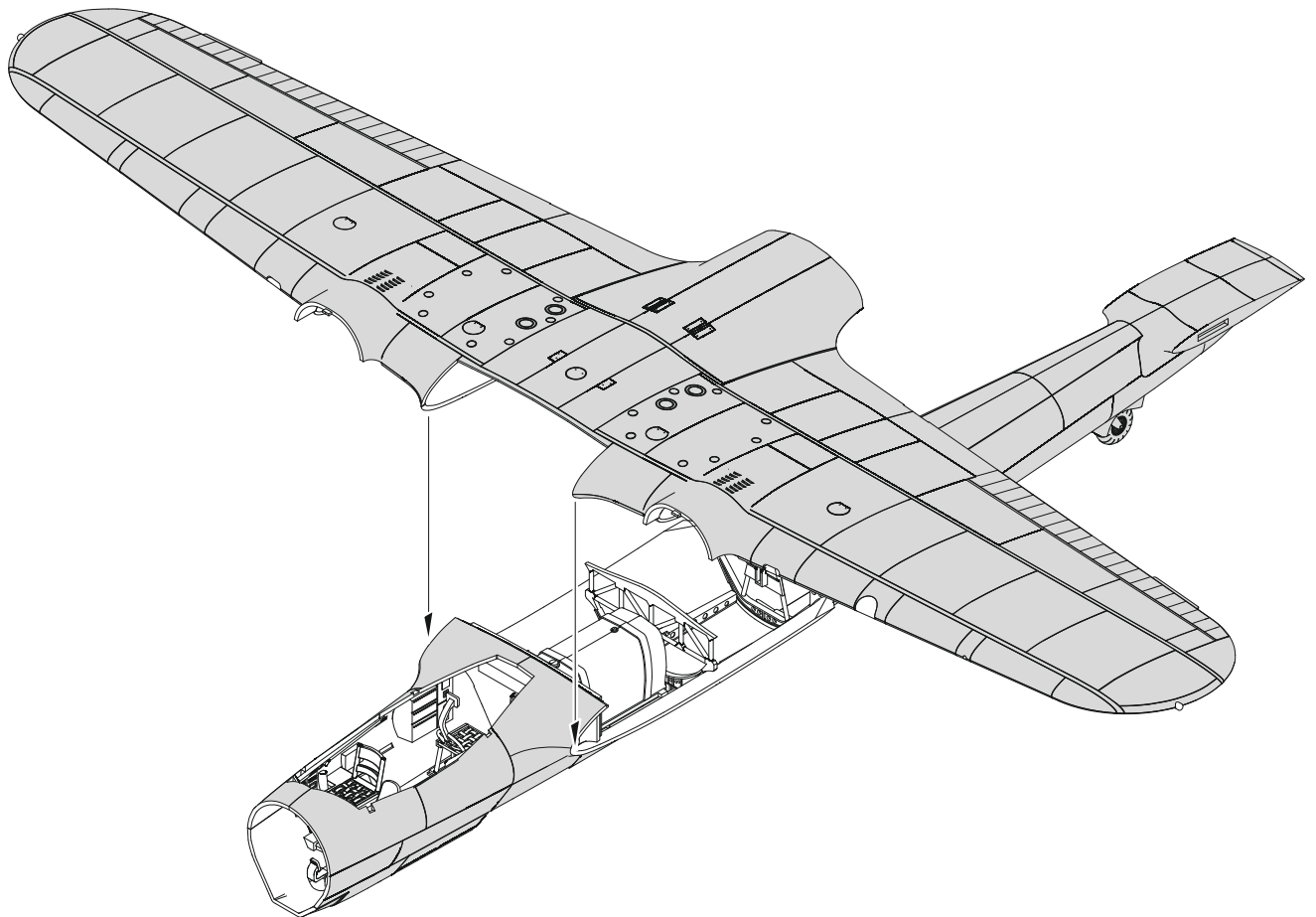
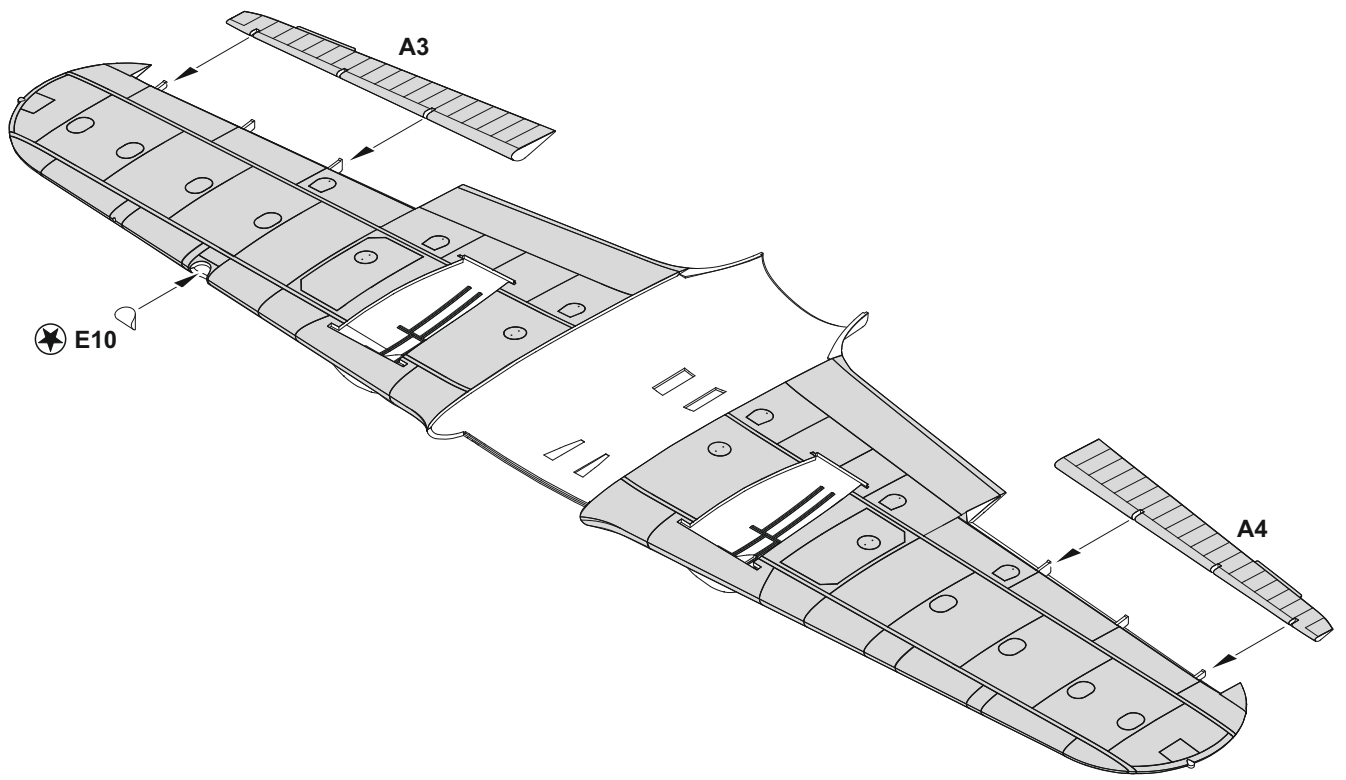

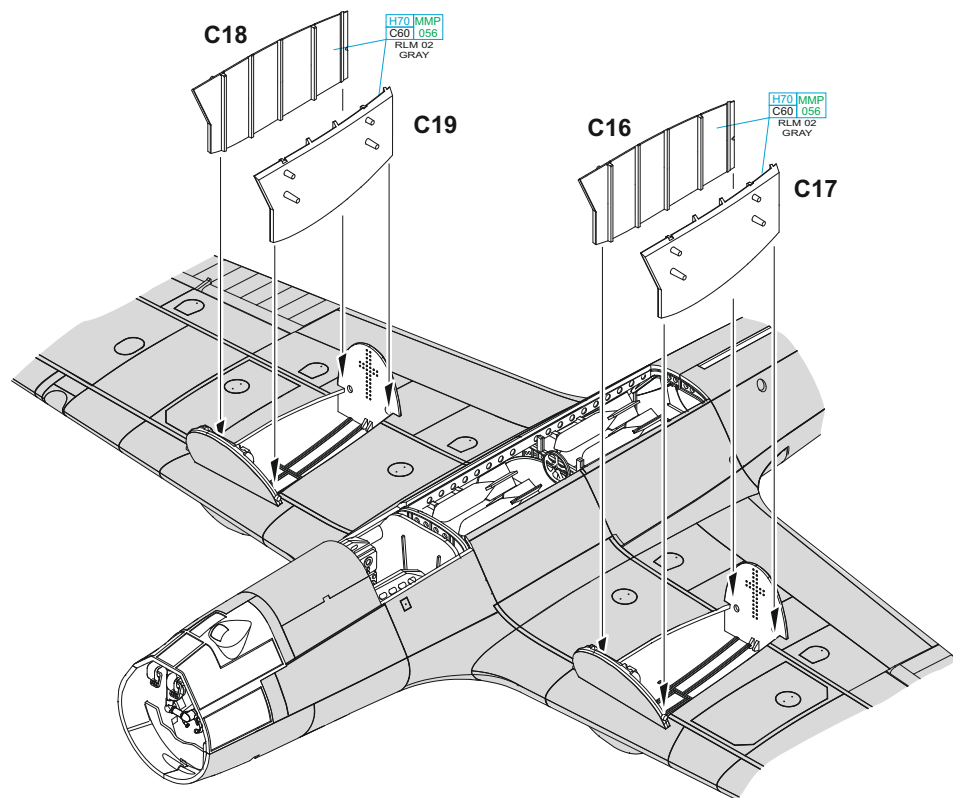
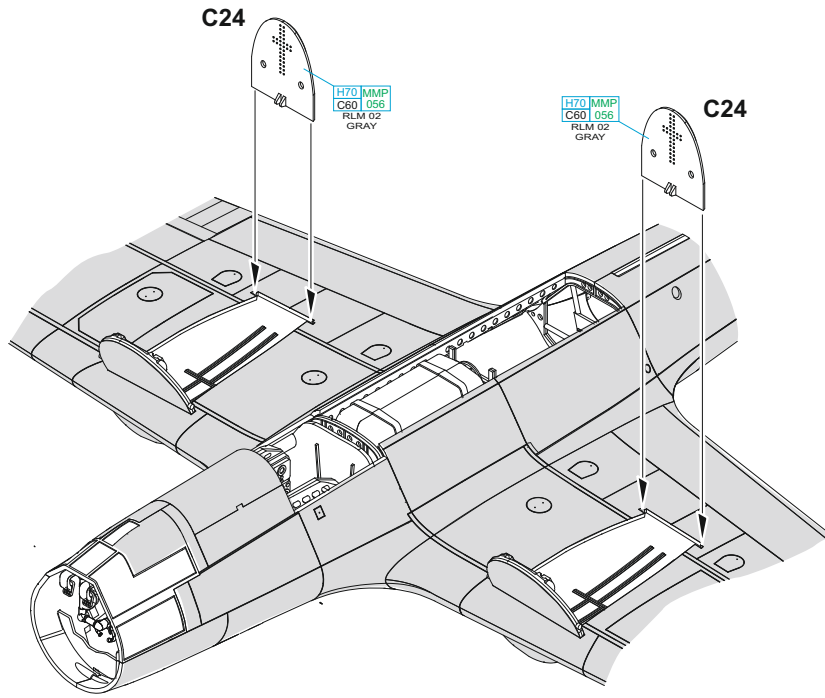

2 pcs.

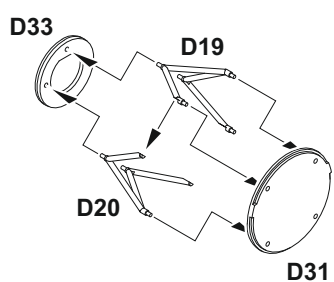

23

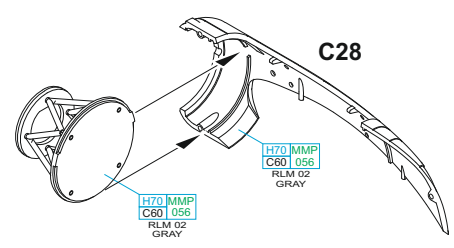

24

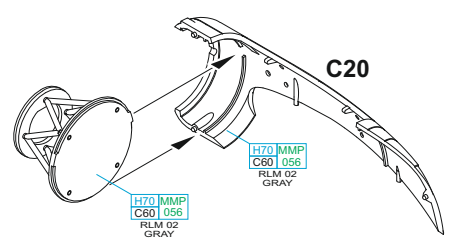

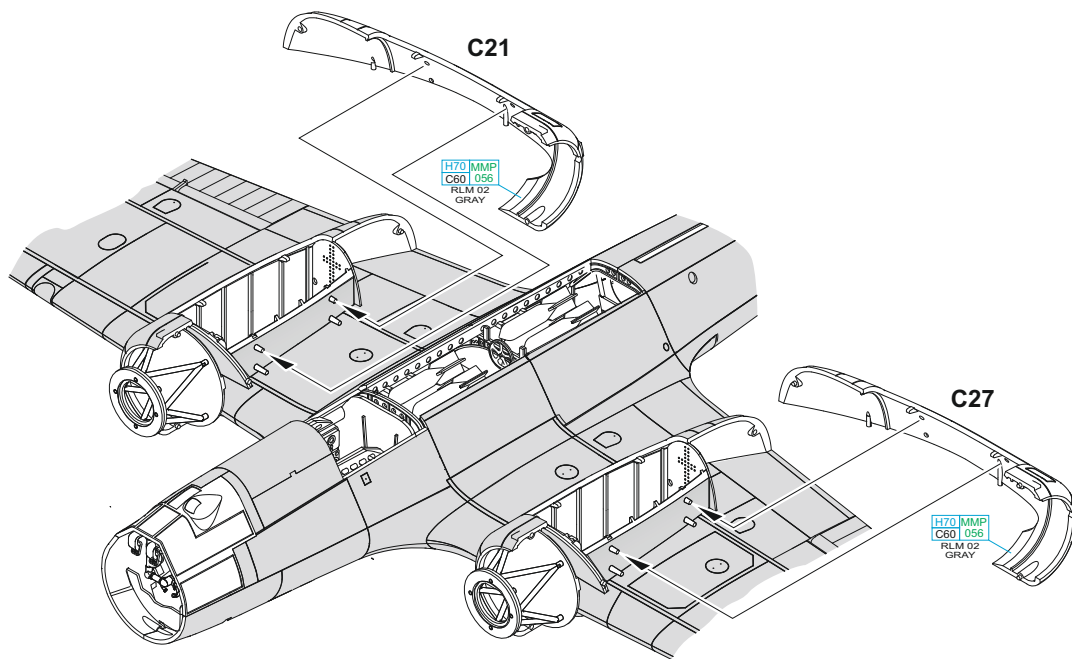
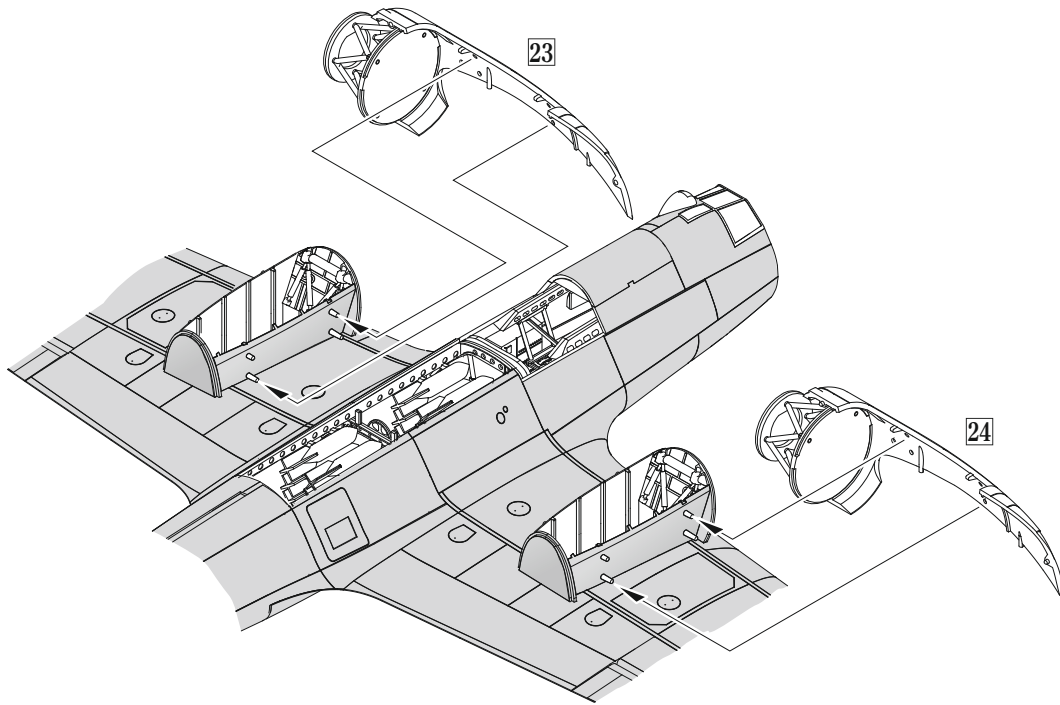

25 2 pcs.

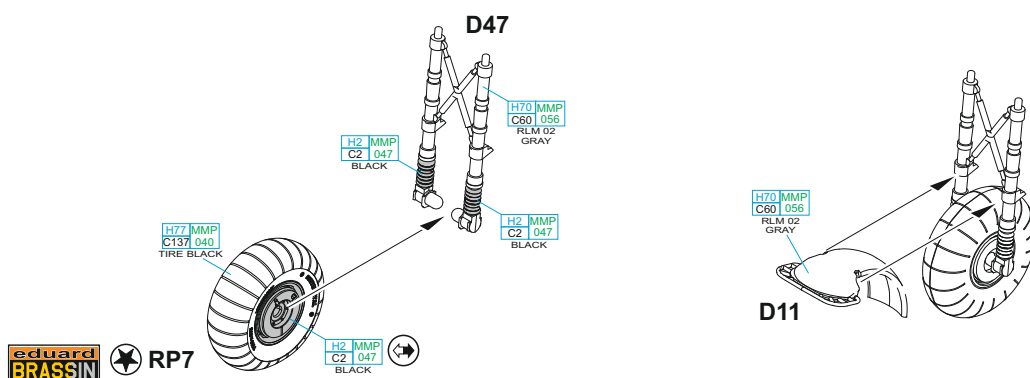

2 pcs.

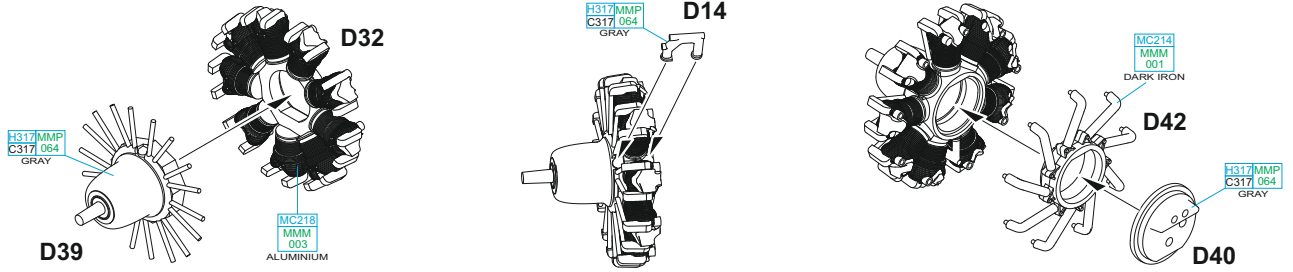

26 ? 2 pcs.

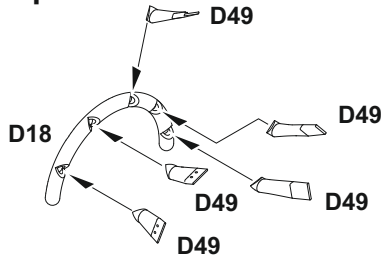

27 ? 2 pcs.

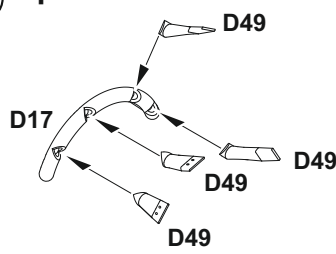

28 2 pcs.



29 ? MARKINGS A;B;C;D 2 pcs.

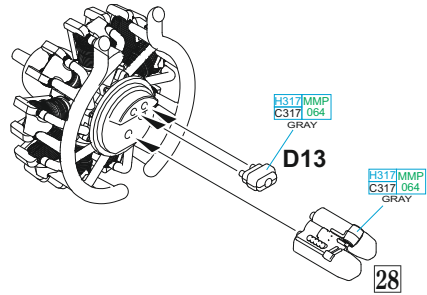
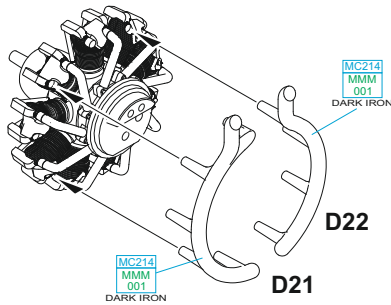

29 ? MARKINGS E;F;G;H 2 pcs.

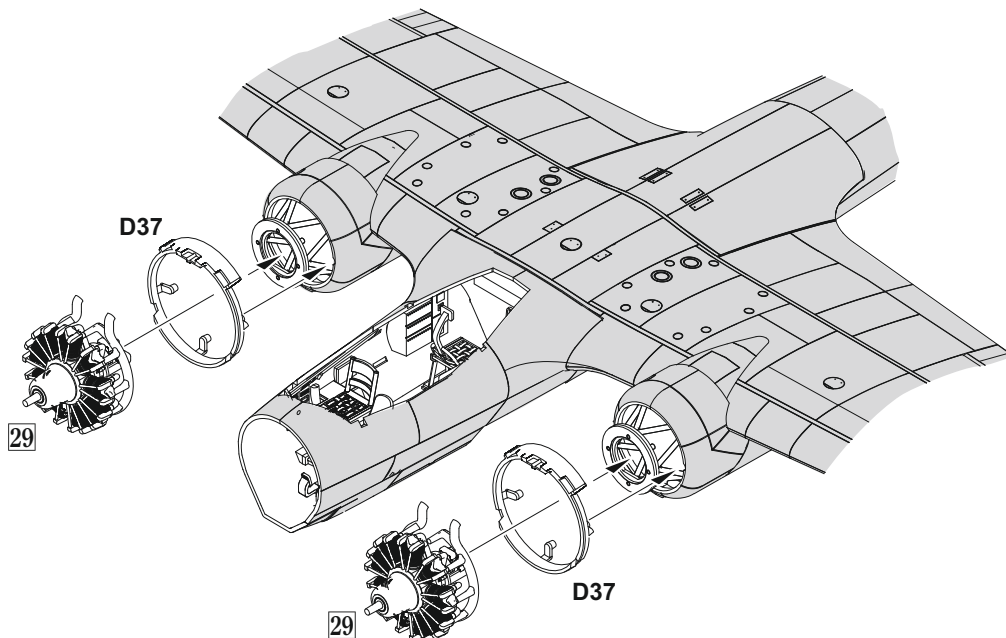
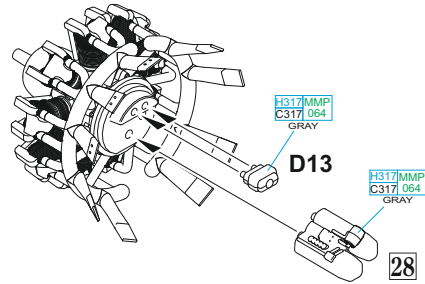
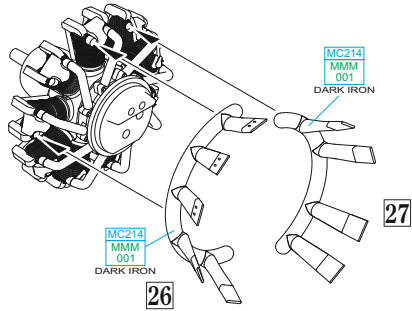

30 2 pcs.

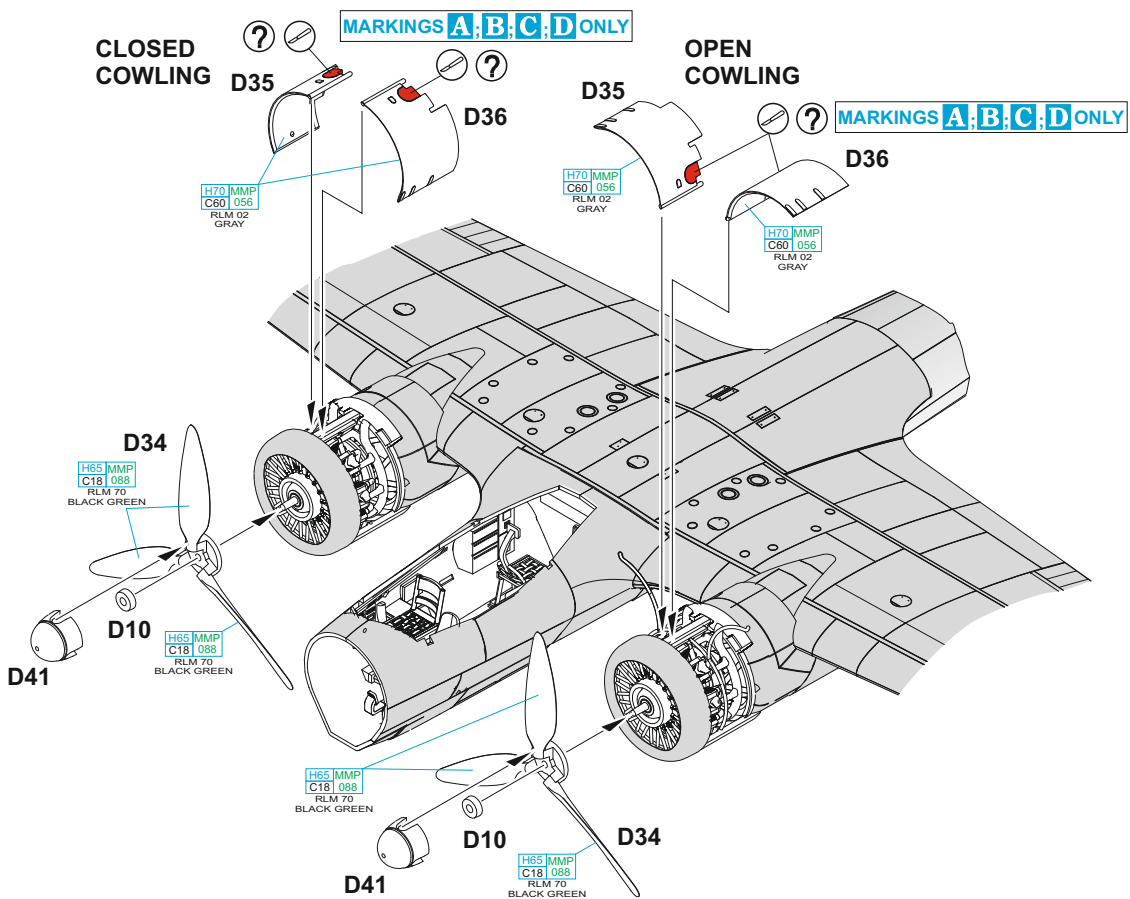
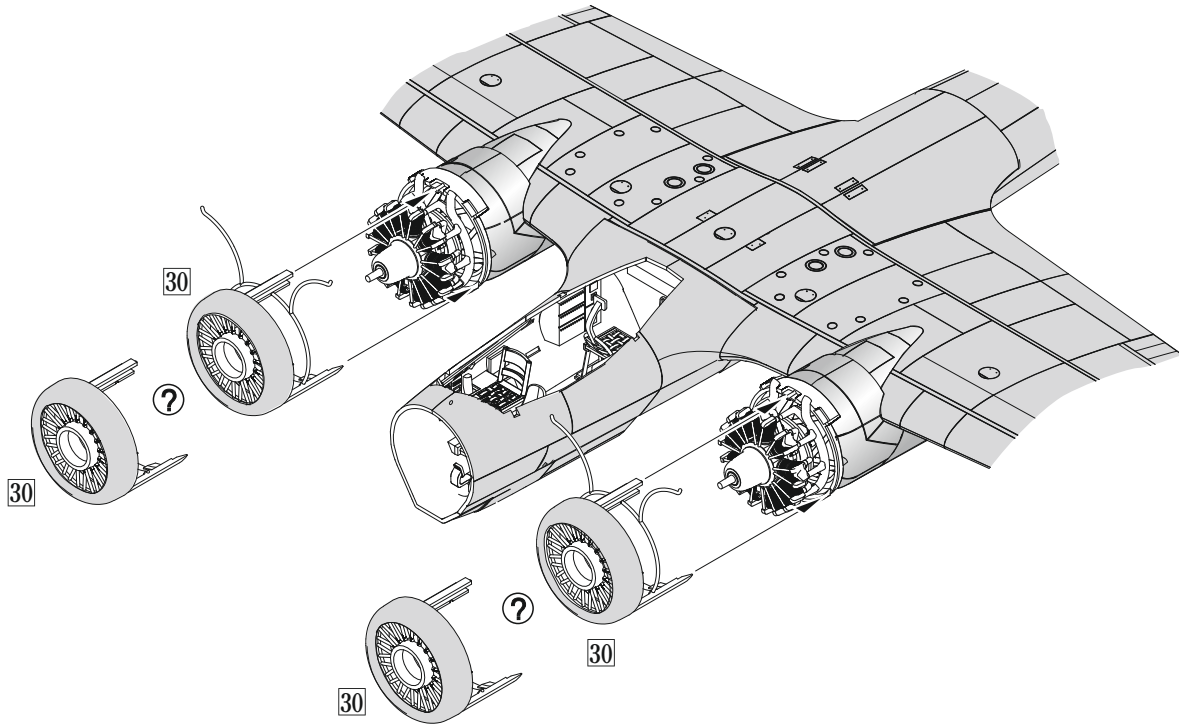
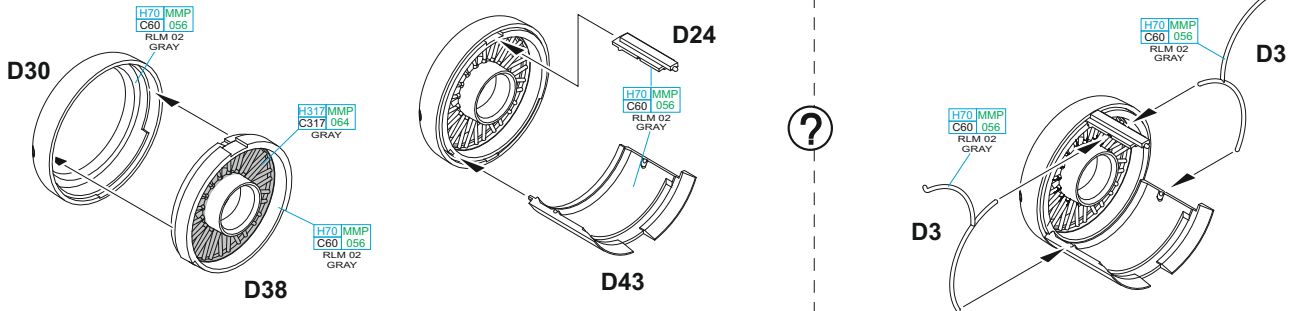

31 2 pcs.

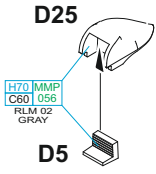

32 2 pcs.

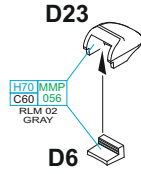

33 **eduard BRASSIN** 2 pcs.

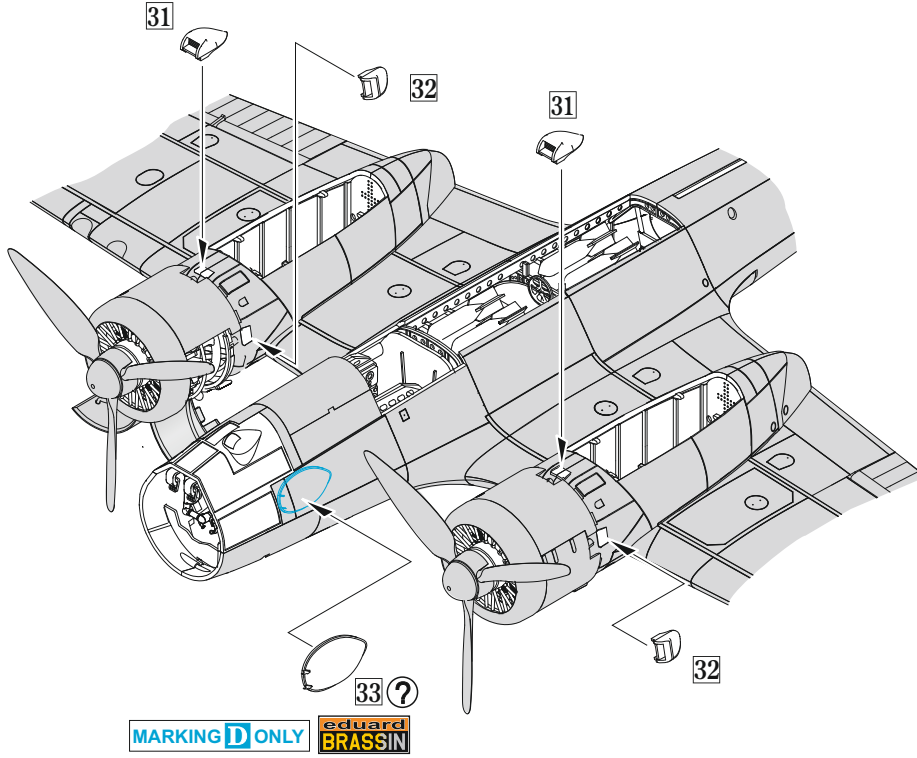
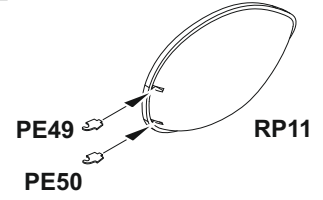

MARKING D ONLY **eduard BRASSIN**

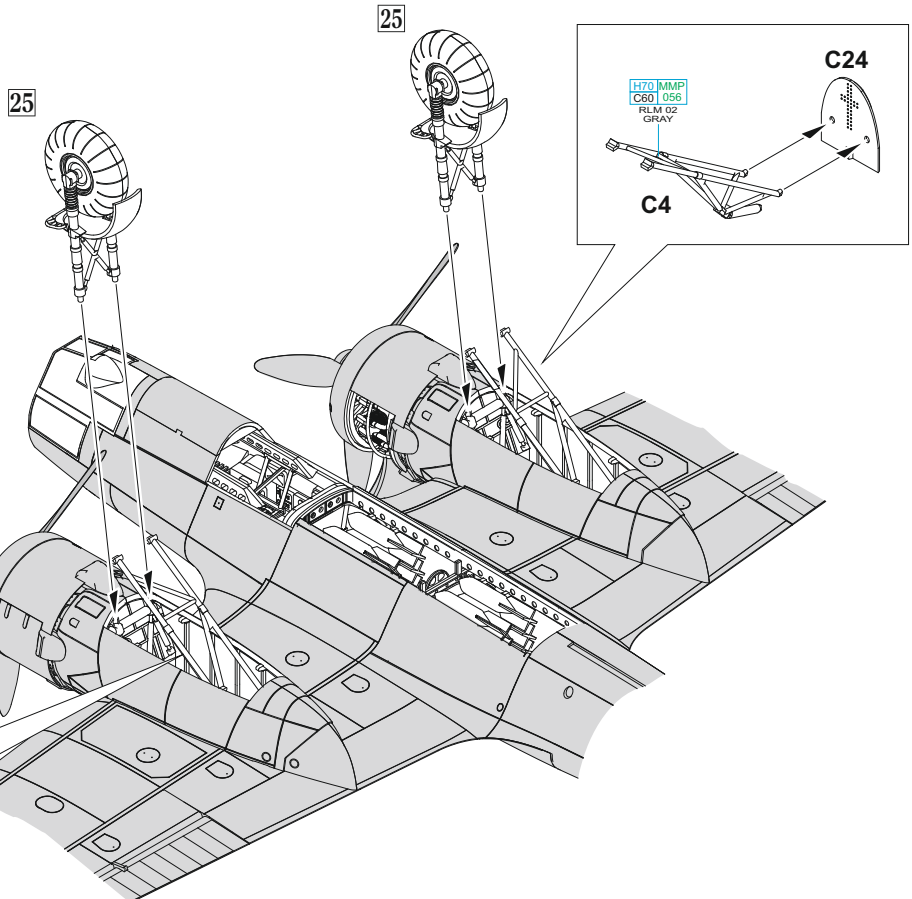

34 2 pcs.

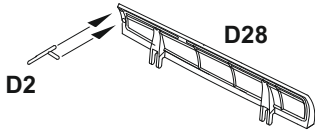

35 2 pcs.

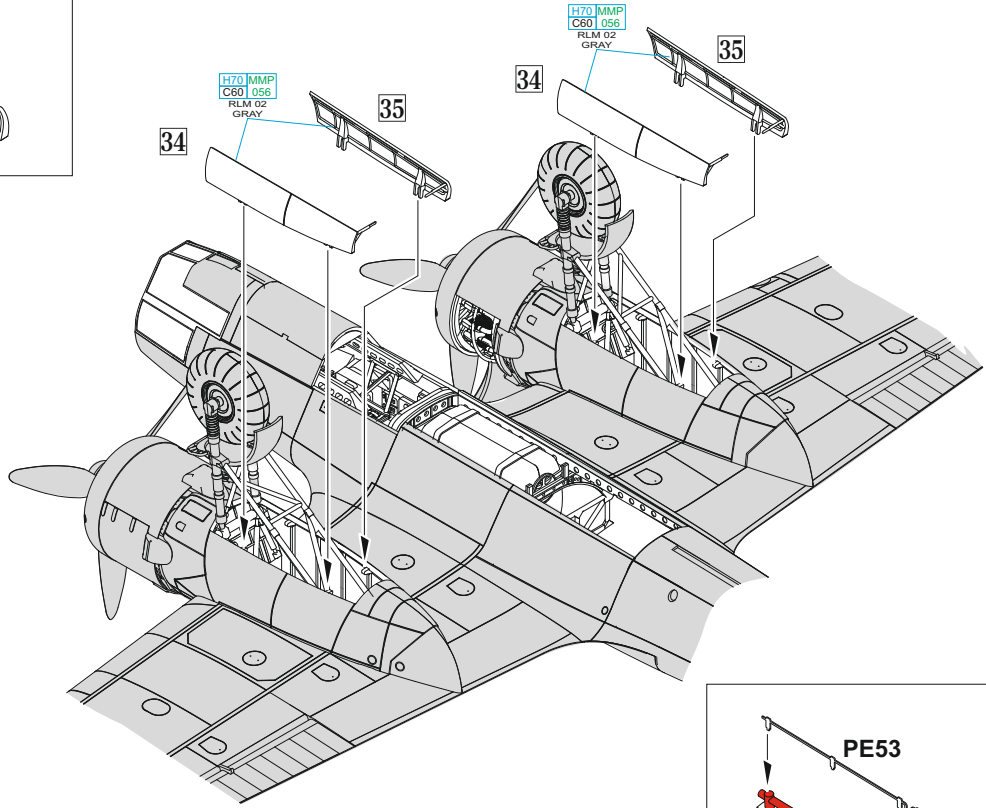
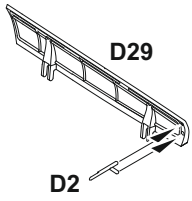

36

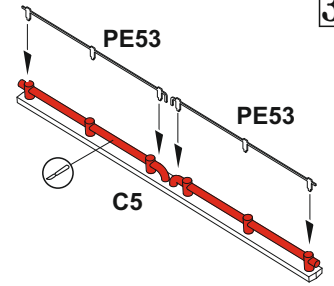

37 6 pcs.

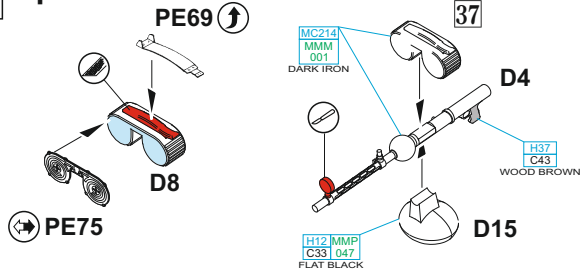

A1, A31 - MARKINGS A - G ONLY

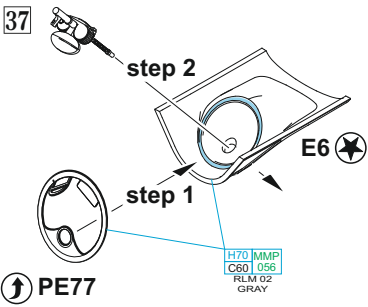
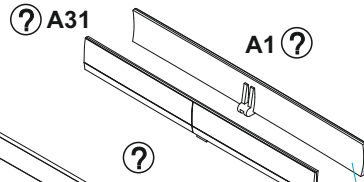

38 5 pcs.

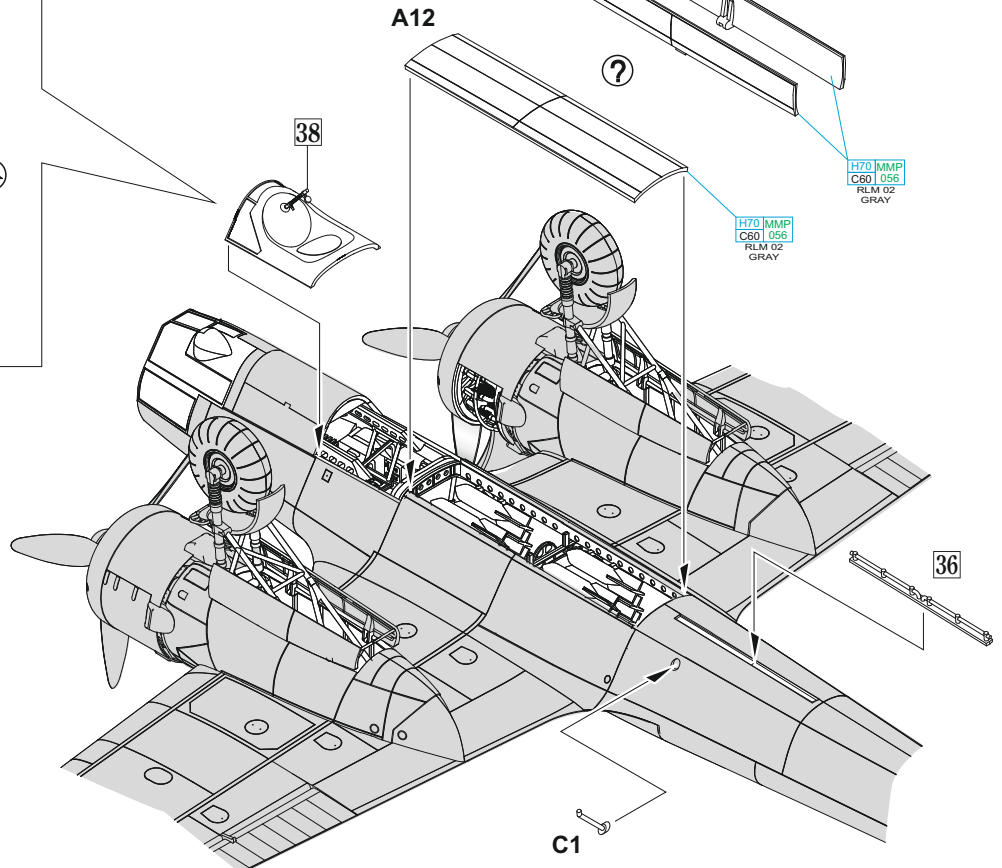
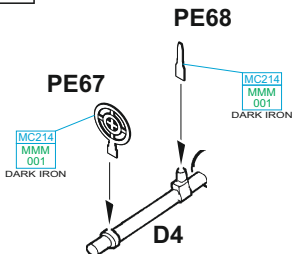

39

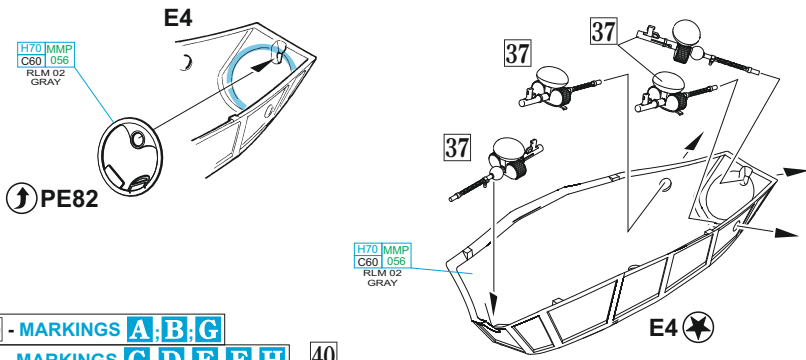

40 - MARKINGS **A; B; G**
 E2 - MARKINGS **C; D; E; F; H**

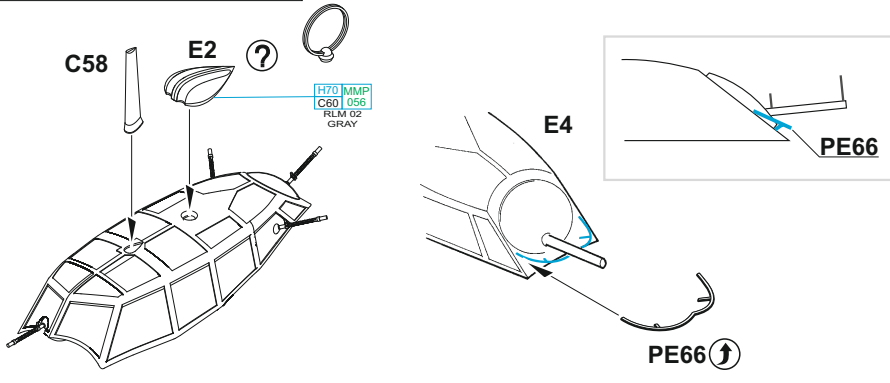

40

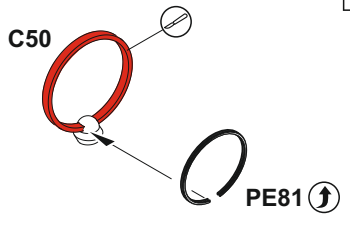

PE78
 PE84

42

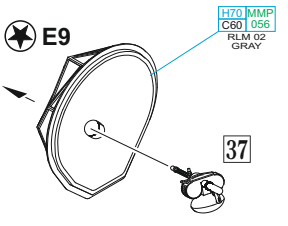

41

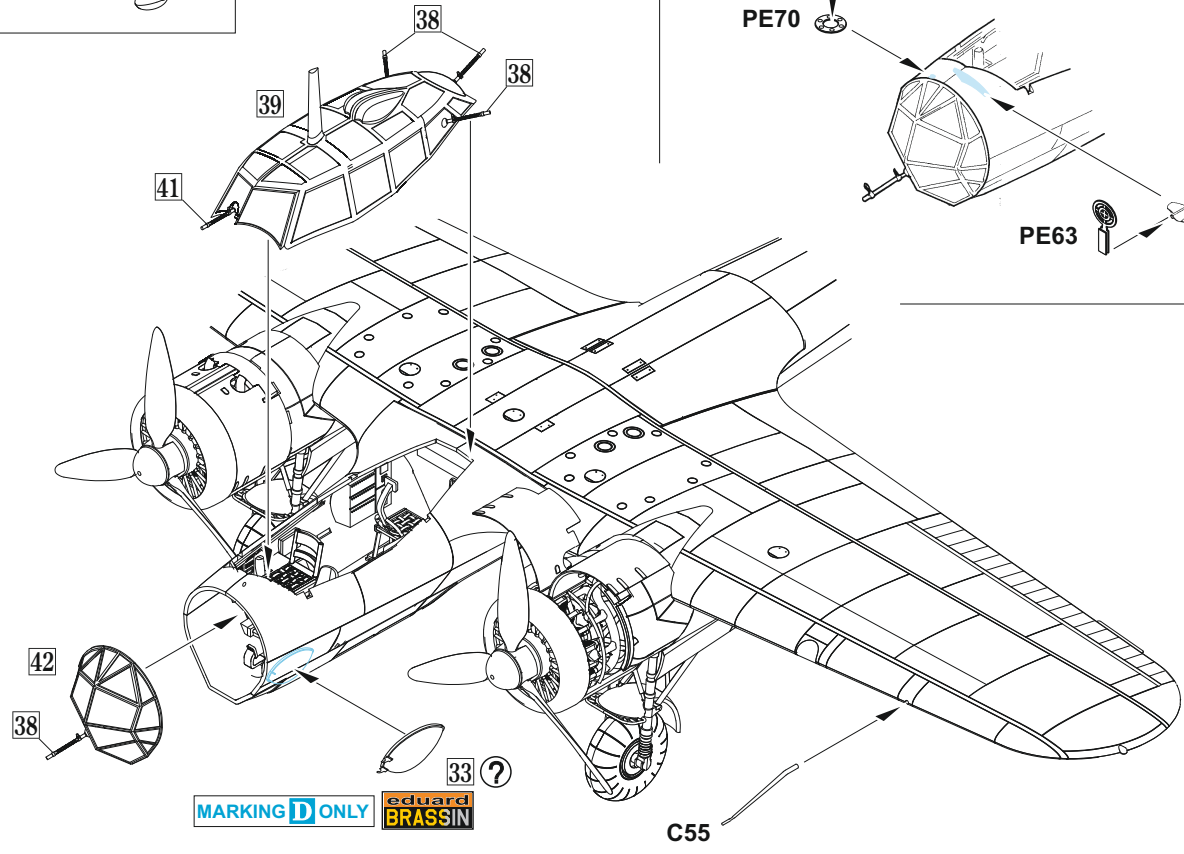
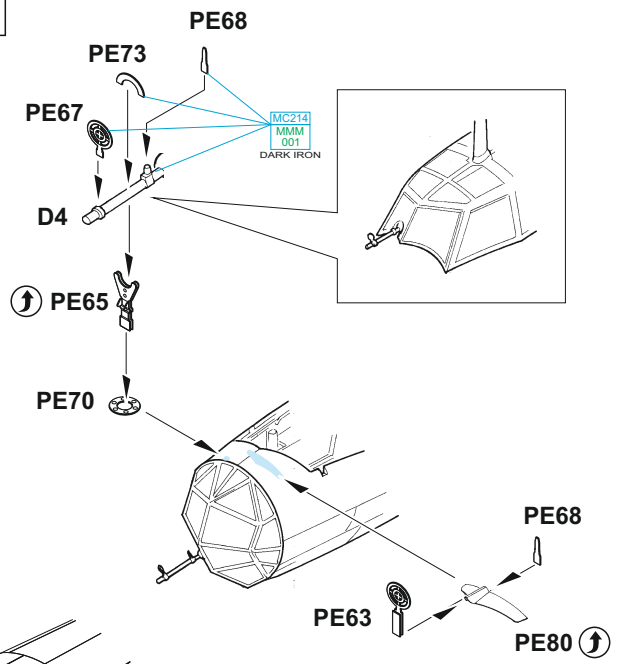

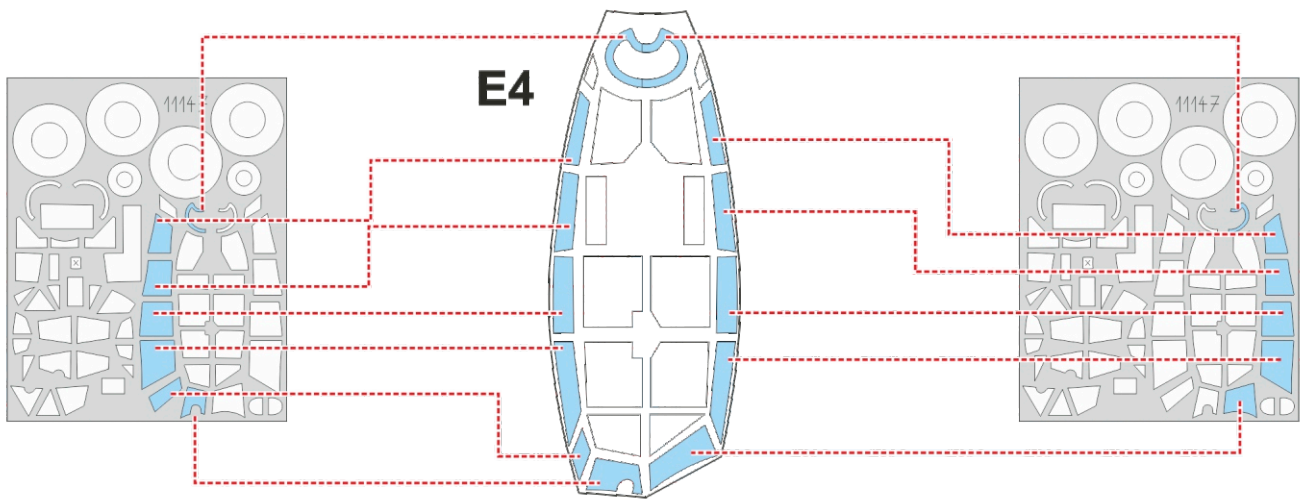
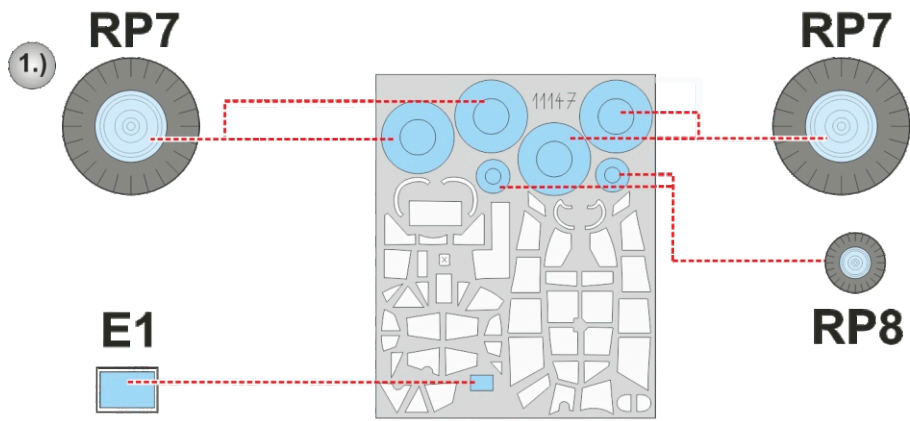

LIQUID MASK

2.)

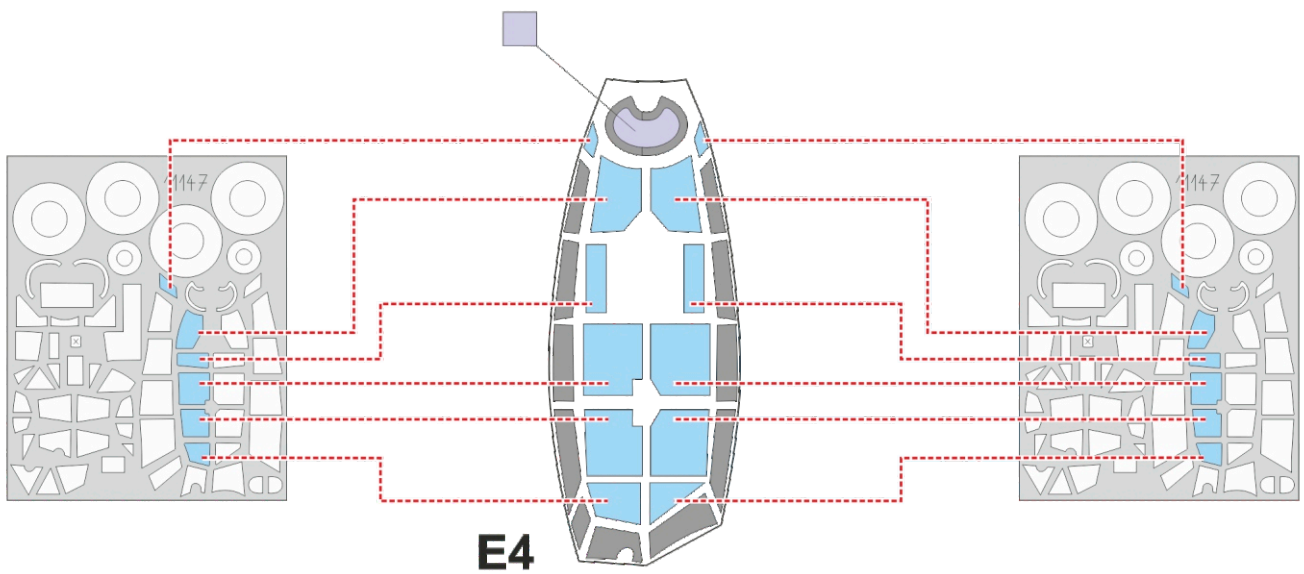

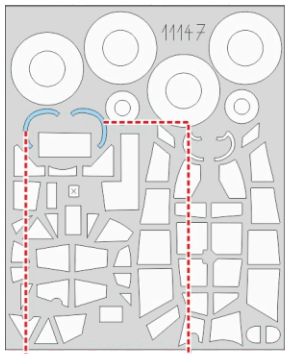

LIQUID MASK

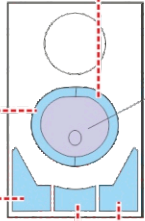

E6

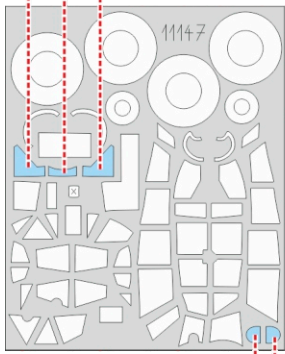

E10



3.)

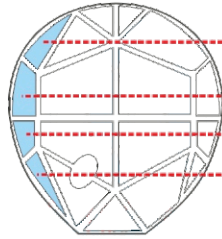

E9

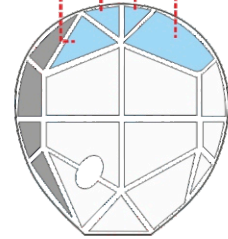
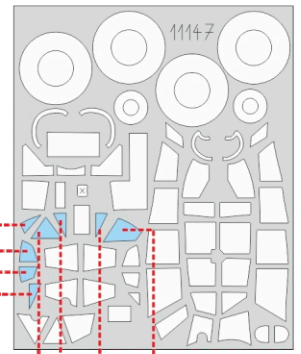

E9

4.)

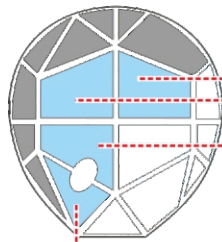

E9

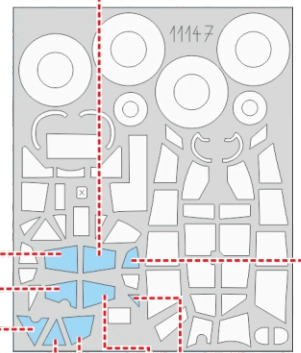

E9

5.)

E3

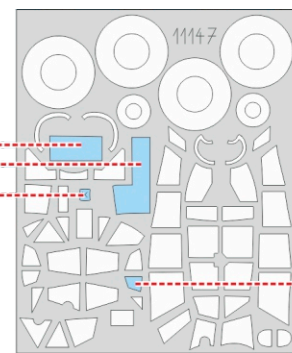
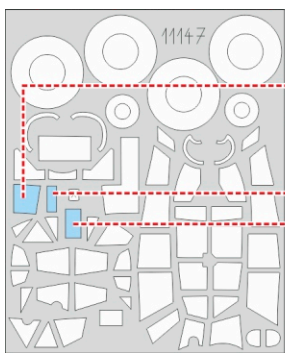
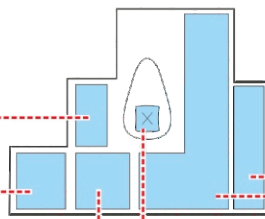

A Do 17Z-1, 5./KG 3, Heiligenbeil, Germany, 1939

Kampfgeschwader 3 was formed on May 1st, 1939 in Fürstenwalde in Brandenburg, with her II. Gruppe at the time flying from nearby Magdeburg. All of the subordinate units were equipped with the Do 17Z, and at the end of May, Stab, II. and III. Gruppe were relocated to Heiligenbeil, located in East Prussia. Training of crews continued there until the invasion of Poland. Both Gruppe took part in this attack. The II. Gruppe, with its Do 17Zs, took part not only in the invasion of Poland, but also in the Battle of France and the subsequent Battle of Britain. The unit converted on to the more modern Ju 88 in the spring of 1941. Do 17Z bombers left the production facility camouflaged on the upper surfaces in RLM 70 and 71, with the lower surfaces sprayed RLM 65. Aircraft of the II. Gruppe carried the unit marking below the cockpit, a scythe in a white circle. The 5th Staffel marking of a stylized bird carrying a bomb was carried on the engine cowls.

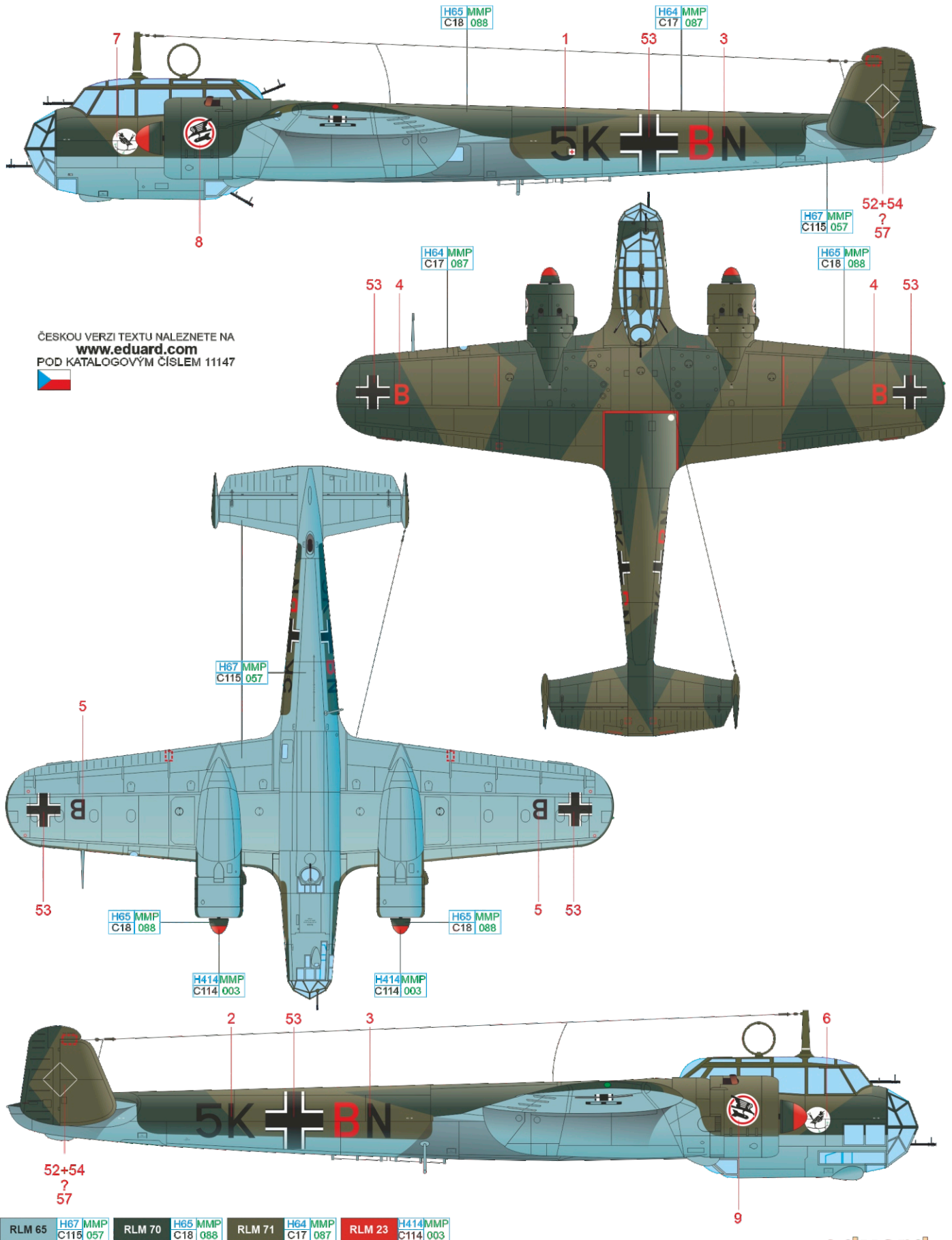

ČESKOU VERZI TEXTU NALEZNETE NA
www.eduard.com
 POD KATALOGOVÝM ČÍSLEM 11147



RLM 65	H67 MMP C115 057	RLM 70	H65 MMP C18 088	RLM 71	H64 MMP C17 087	RLM 23	H414 MMP C114 003
--------	---------------------	--------	--------------------	--------	--------------------	--------	----------------------

B Do 17Z-2, WNr. 1160, 7./KG 3, St. Trond, Belgium, August 1940

The last action to be undertaken during the Battle of Britain by the crew commanded by Fw. Willi Effmert (who was the pilot, bombardier Uffz. Ritzel, radio operator Uffz. Reinhardt and observer Gefr. Huhn) was an attack on the base at Debden and Hornchurch, planned for August 26th, 1940. During the raid, this aircraft was shot down by a Defiant from No.264 Squadron, RAF. Only the pilot and the bombardier survived. The wreck of this aircraft was discovered in 2008, not far from the coast of the County of Kent. It was raised in 2013 and is currently on display at the RAF museum in Cosford. The unit marking carried under the cockpit of aircraft of the III. Gruppe were playing cards and the Stab aircraft all the card colours, and aircraft of the 7. Staffel carried clubs.

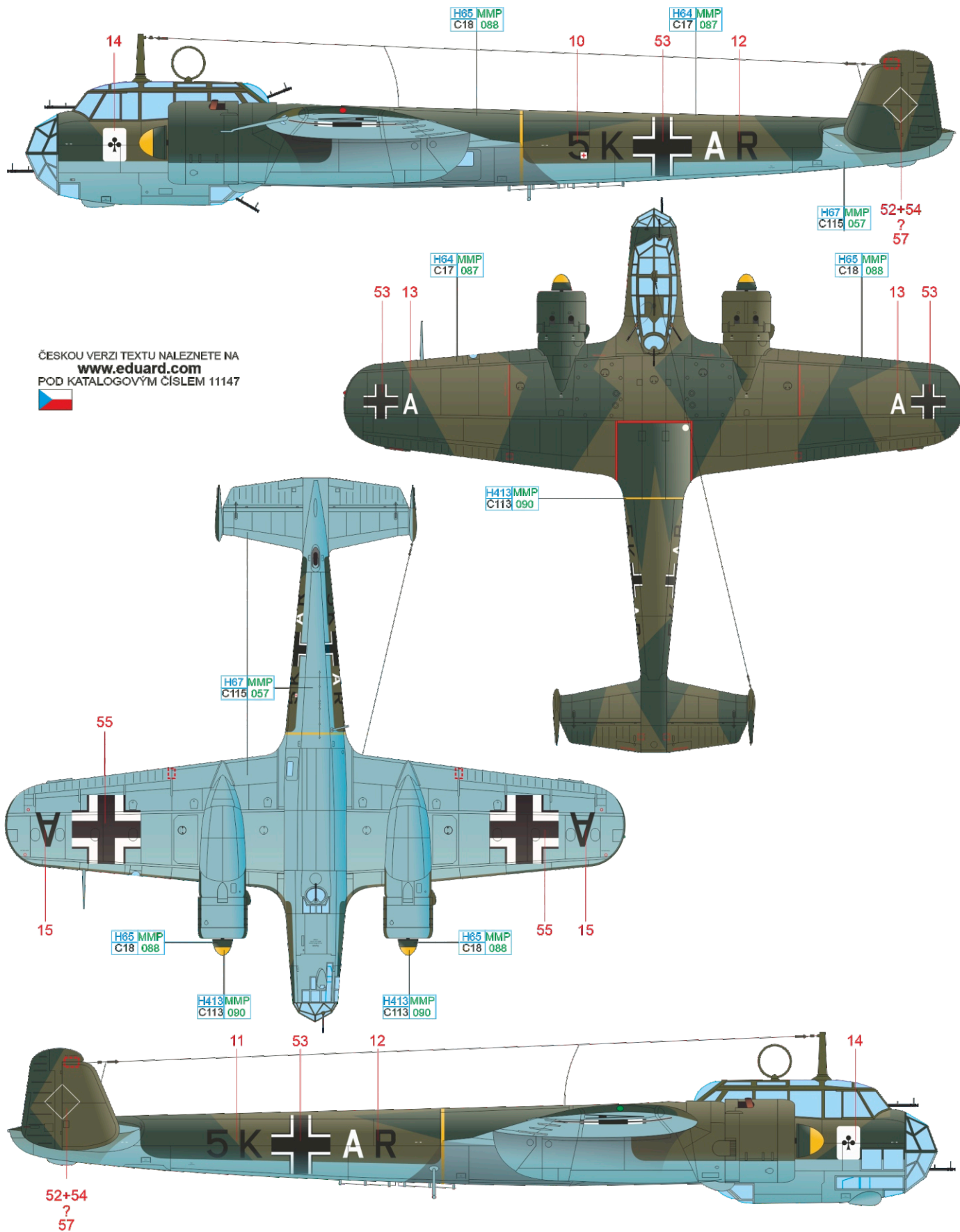

ČESKOU VERZI TEXTU NALEZNETE NA
www.eduard.com
 POD KATALOGOVÝM ČÍSLEM 11147



RLM 65	H67 MMP C115 057	RLM 70	H65 MMP C18 088	RLM 71	H64 MMP C17 087	RLM 04	H413 MMP C113 090
--------	------------------	--------	-----------------	--------	-----------------	--------	-------------------

C Do 17Z-2, WNr. 2555, 8./KG 76, Cormeilles-en-Vixen, France, September 1940

On August 15th, 1940, at ten minutes after noon, this aircraft was shot down by Spitfires from No.609 Squadron flown by F/O Dundas and F/O Tobin. The pilot of the Dornier bellied in near Castle Farm at Shoreham. Outside of observer Fw. Schmid, who was fatally wounded in the intercept, the crew was taken prisoner. Do 17Zs of the 8. Staffel KG 76 carried the unit insignia under the cockpit, a red shield with three white bomber silhouettes and a bomb in the background. Other identifying markings were the red fuselage band behind the wing and red spinner tips. The aircraft letter 'F' in red (the colour of the 8. Staffel within the III. Gruppe) was edged in white. White, and in the case of KG 76, pink, bands, used during the Battle of Britain as a formation flying aid, were painted on the top surface of the left wing and on the outside surfaces of the fin and rudders.

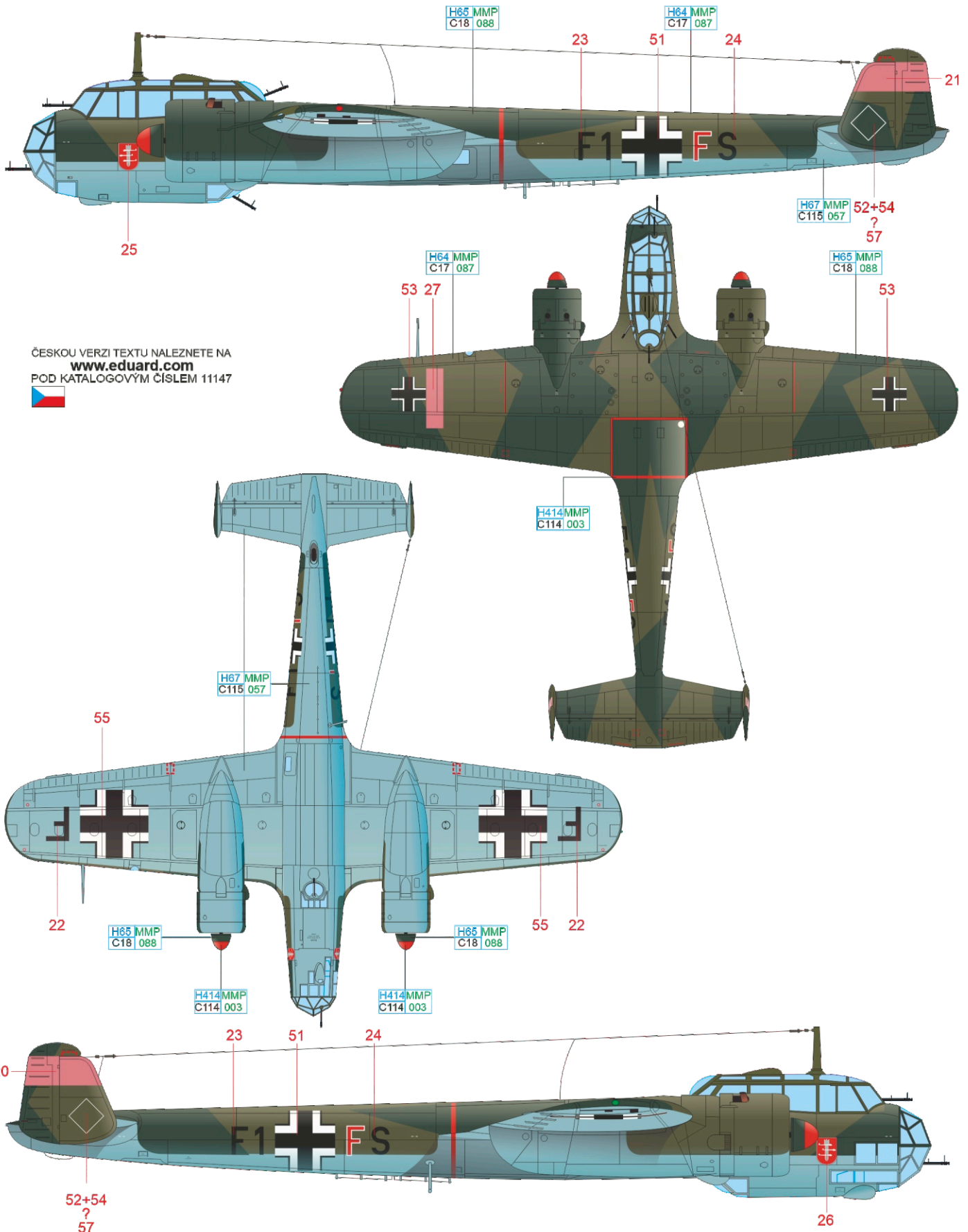

ČESKOU VERZI TEXTU NALEZNETE NA
www.eduard.com
 POD KATALOGOVÝM ČÍSLEM 11147



RLM 65	H67 MMP C115 057	RLM 70	H65 MMP C18 088	RLM 71	H64 MMP C17 087	RLM 23	H414 MMP C114 003
--------	---------------------	--------	--------------------	--------	--------------------	--------	----------------------

D Do 17Z-5, WNr. 2787, 1./KGr. 606, Lannion, France, October 1940

The Do 17Z-5 was equipped with floatation cells in the nose in order to give the crew more time to escape the aircraft in cases of setting down on water. These aircraft were issued to Küstenfliegergruppe 606 as a matter of priority, a unit that specialized in attacking surface vessels. This aircraft was heavily damaged on October 11th, 1940 during an attack on Liverpool, when No.611 Squadron Spitfires lit up both of its engines. Two members of the crew (the radiooperator and mechanic) bailed out of the aircraft, while the pilot and observer were able to actually make to France and make an emergency landing near Brest. The mechanic, Uffz. Johansen, was struck by the tail surfaces of the aircraft and died before he hit the ground after bailing out over England. The radio operator reached the ground unscathed near Mart of Llyn and was captured. After a change in tactics that involved the bombing of English cities under the cover of darkness, the undersides of the aircraft, as well as the white portions of the balkenkreuz and swastikas on other surfaces, were painted black, which was the case here as well. The unit emblem appears below the cockpit.

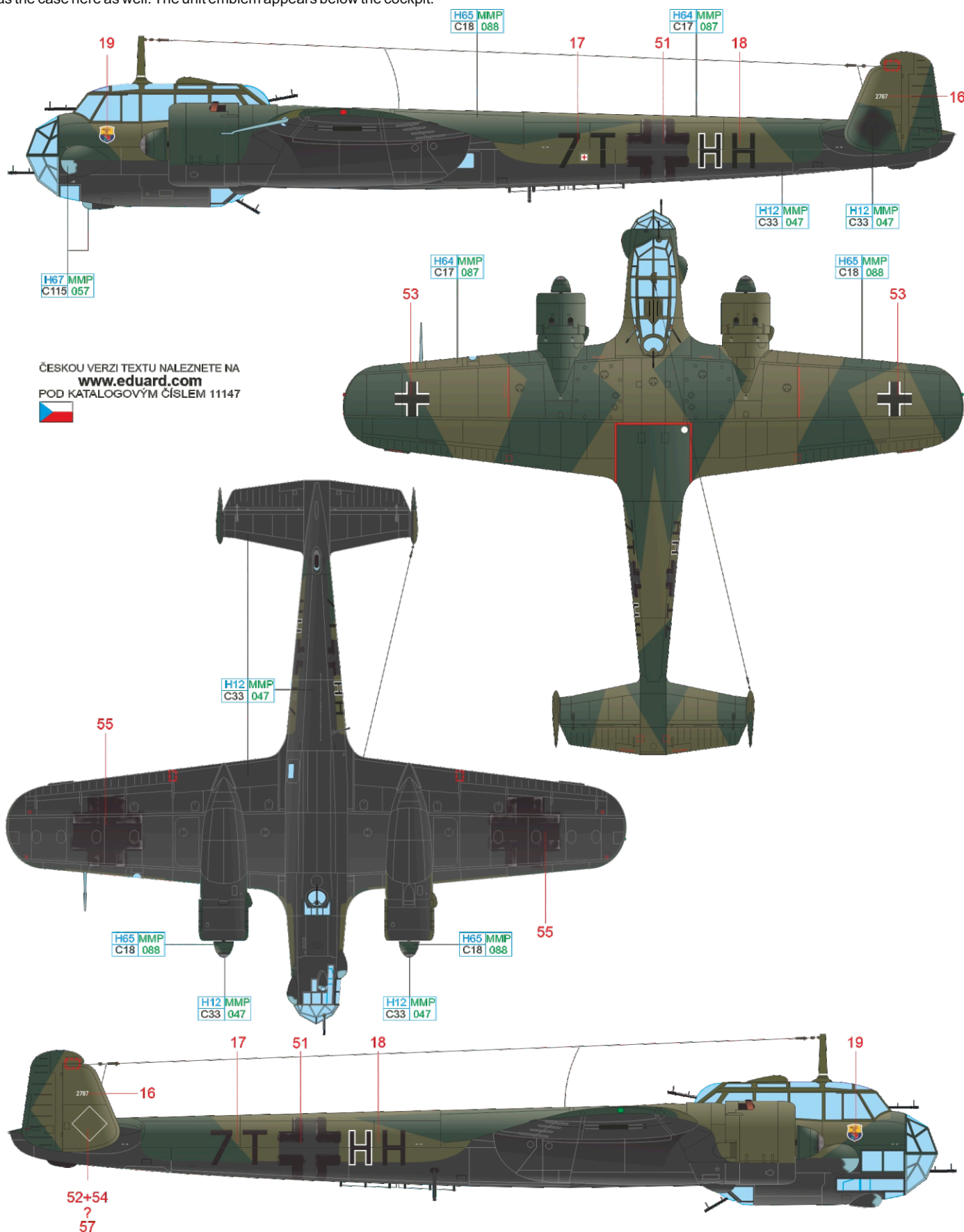

ČESKOU VERZI TEXTU NALEZNETE NA
www.eduard.com
 POD KATALOGOVÝM ČÍSLEM 11147



RLM 65 H67 MMP C115 057 RLM 70 H65 MMP C18 088 RLM 71 H64 MMP C17 087 BLACK H12 MMP C33 047

E Do 17Z-2, 3./KG 2, Athens-Tatoi, Greece, May 1941

One of the bomber units taking part in the Balkans campaign under Operation Marita (the attack on Greece) was Kampfgeschwader 2. This unit's Stab, I. and III. Gruppe (the contribution of II. Gruppe was largely symbolic) attacked from the Bulgarian airfield at Plovdiv-Krumovo, and after the occupation of Macedonia, KG 2 moved to Thessaloniki, and by the very end of the actions against Greece, the unit operated from Tatoi airfield in Athens. Aircraft that took part in Operation Marita carried RLM 04 engine cowls and control surfaces in the tail. The unit insignia was carried under the cockpit.

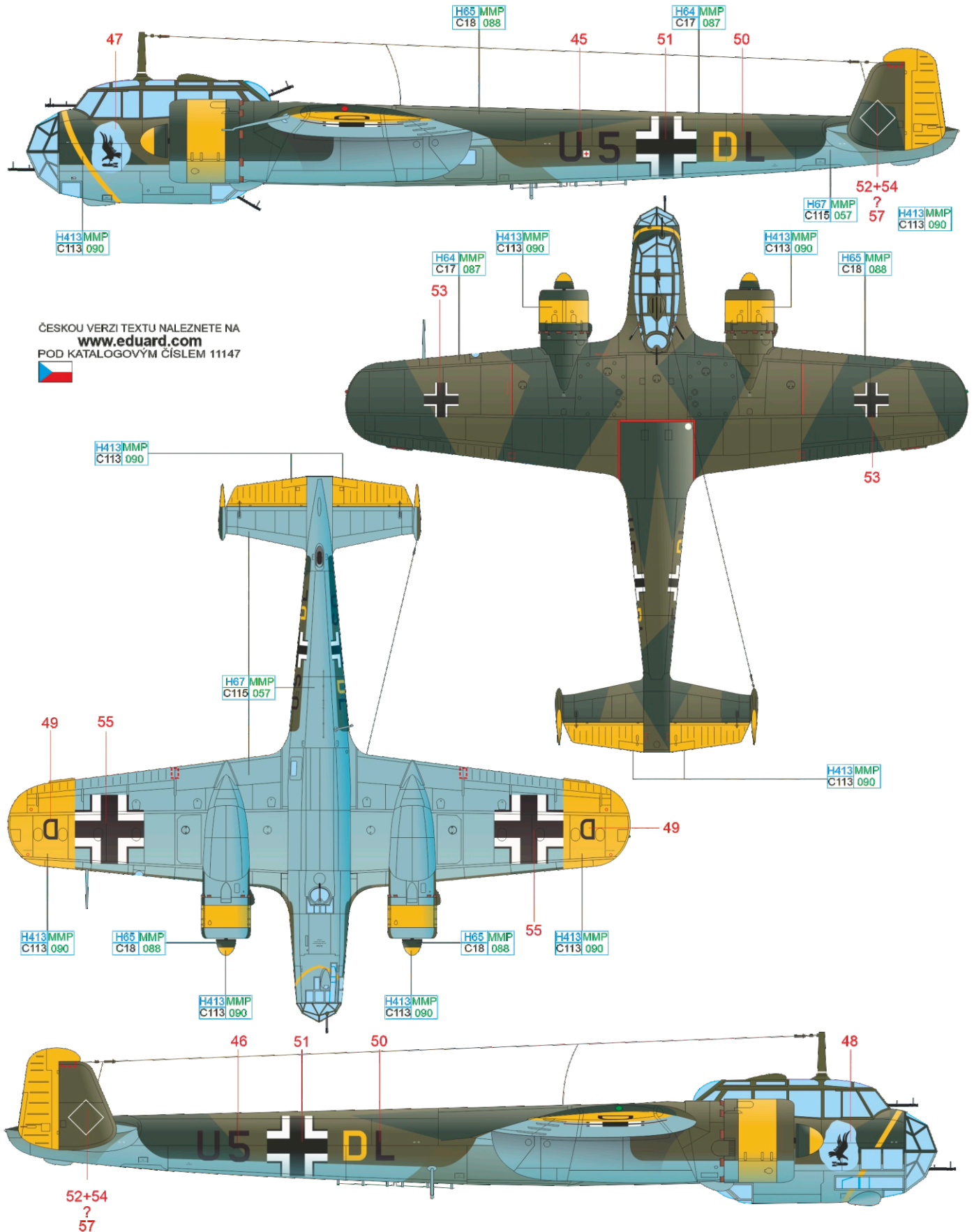

ČESKOU VERZI TEXTU NALEZNETE NA
www.eduard.com
 POD KATALOGOVÝM ČÍSLEM 11147



RLM 65	H67 MMP C115 057	RLM 70	H65 MMP C18 088	RLM 71	H64 MMP C17 087	RLM 04	H413 MMP C113 090
--------	---------------------	--------	--------------------	--------	--------------------	--------	----------------------

F Do 17Z, 7./KG 3, Wjazma, Soviet Union, Winter 1941

Over the course of the winter months of the war against the Soviets, fighters and bombers alike received applications of temporary white paint on their upper surfaces in an effort to better conceal them from the enemy when on the ground or in the air. These paints were applied at unit level and with whatever method that was possible with no real preparation, and the paint tended to wear away very quickly under the traffic of the groundcrews, and the adverse weather conditions played a role as well. It was the same with bombers of the 7. Staffel KG 3, the last unit conducting operational flights with the by-then obsolete Do 17Z. Below the temporary, washable white paint, the original camouflage scheme consisting of RLM 70/71 was visible on the upper surfaces, and the lower ones were sprayed RLM 65. Service on the Eastern Front was signified by the yellow fuselage band ahead of the tail surfaces and the yellow lower wingtips.

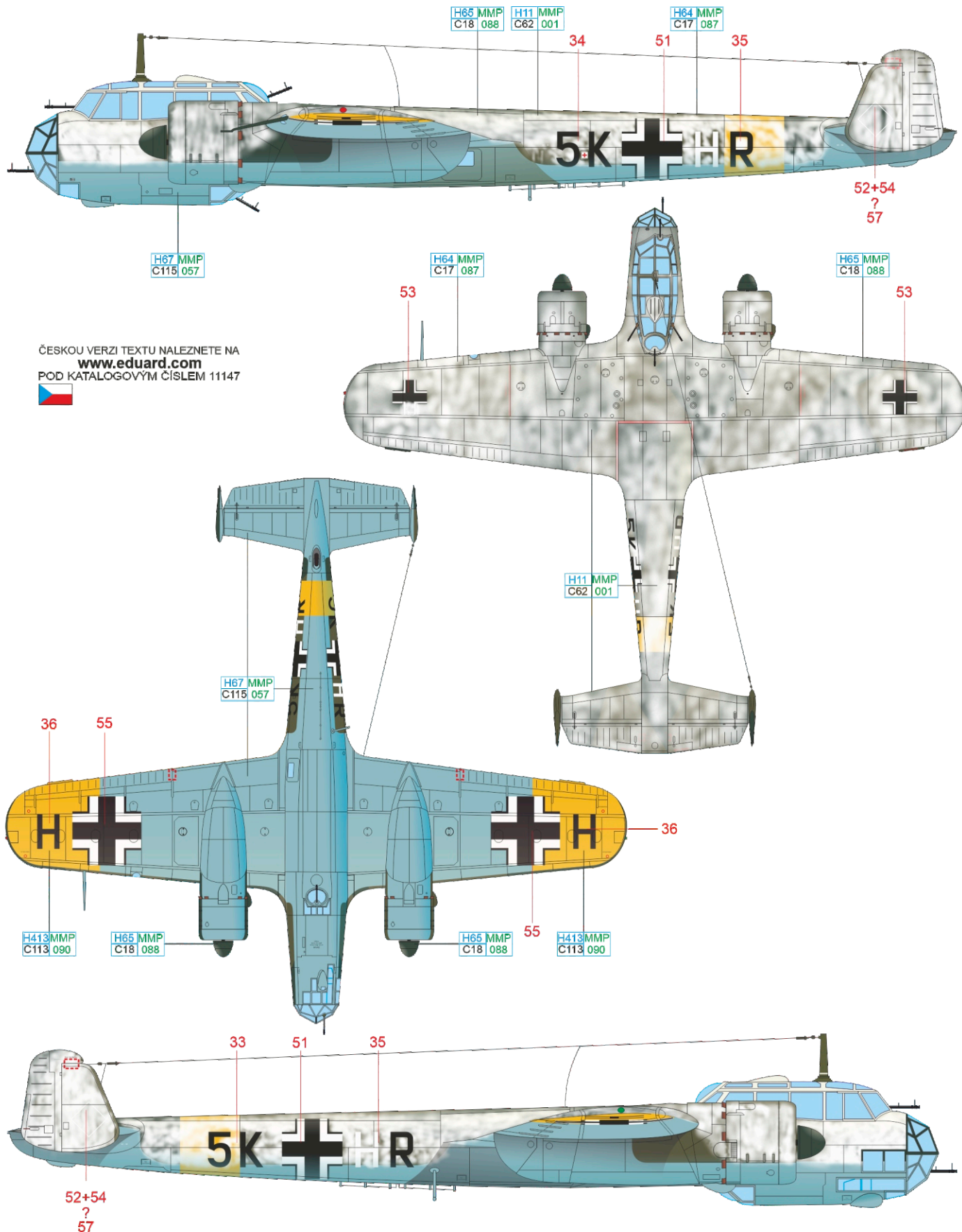

ČESKOU VERZI TEXTU NALEZNETE NA
www.eduard.com
 POD KATALOGOVÝM ČÍSLEM 11147



RLM 65	H67 MMP C115 057	RLM 70	H65 MMP C18 088	RLM 71	H64 MMP C17 087	RLM 04	H413 MMP C113 090	WHITE	H11 MMP C62 001
--------	---------------------	--------	--------------------	--------	--------------------	--------	----------------------	-------	--------------------

G Do 17Z-2, 10./ZG 26, Castel Benito, Libya, 1941

The Do 17Z, used by several Luftwaffe bomber units in the early phases of the Second World War, took part in every conflict undertaken by Nazi Germany. North Africa was no exception. Here, however, the use of the type was largely symbolic, and a few served with the 10. Staffel Zerstörergeschwader 26, a unit flying the twin-engined Bf 110. This particular aircraft was discovered by advancing British troops at Castel Benito in Libya. Aircraft used in North Africa were camouflaged to suit the environment with upper and side surfaces painted RLM 79 with squiggle patterns of RLM 80, while the lower surfaces were in RLM 78. It is not clear from photographs if this aircraft had the RLM 80 squiggle pattern applied. As with other aircraft on the southern front, this plane carried a white fuselage band ahead of the tail surfaces and white lower wingtips.

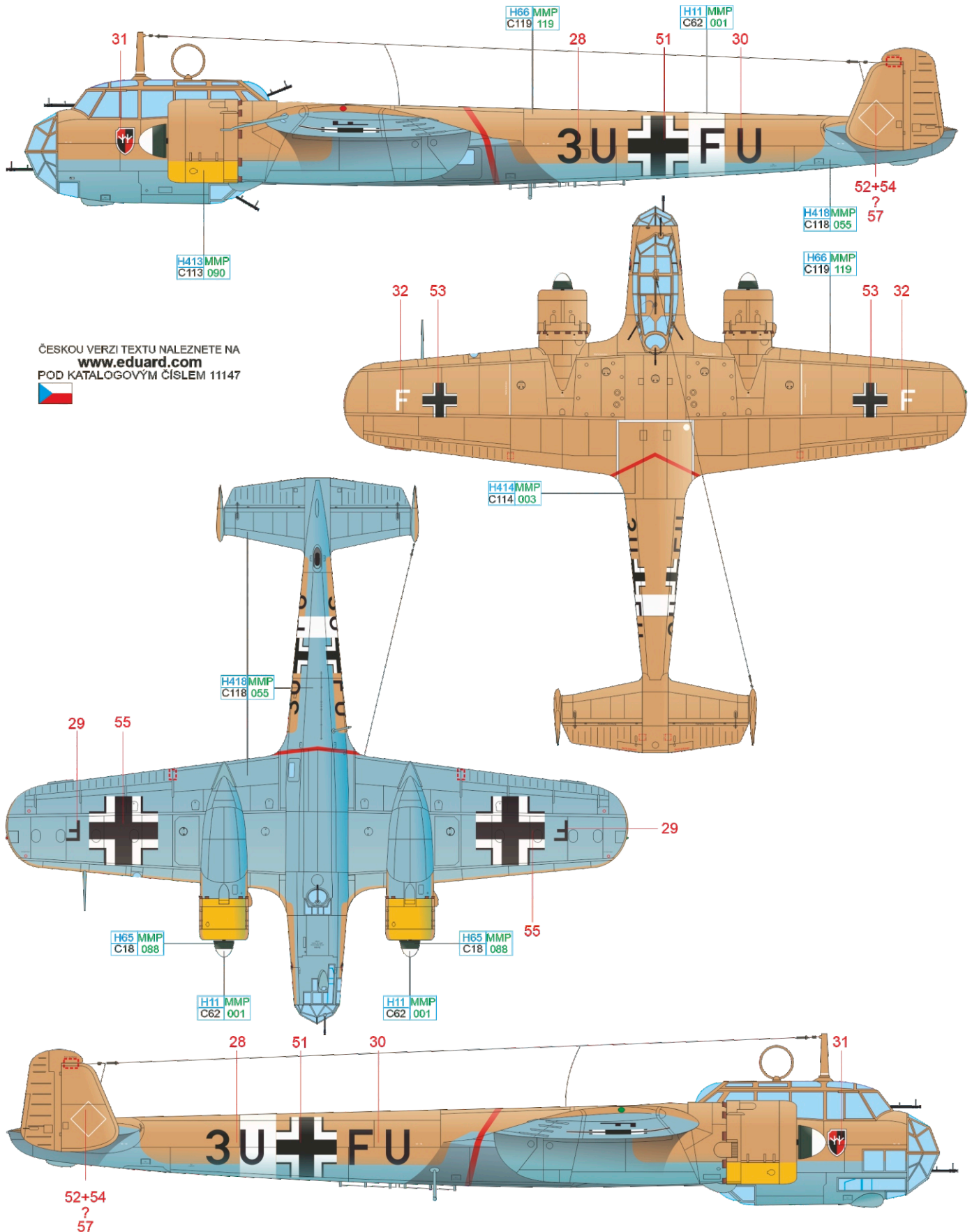

ČESKOU VERZI TEXTU NALEZNETE NA
www.eduard.com
 POD KATALOGOVÝM ČÍSLEM 11147



RLM 79	H66 MMP C119 119	RLM 78	H413 MMP C113 090	RLM 04	H418 MMP C118 055	RLM 23	H414 MMP C114 003	RLM 70	H65 MMP C18 088	WHITE	H11 MMP C62 001
--------	------------------	--------	-------------------	--------	-------------------	--------	-------------------	--------	-----------------	-------	-----------------

H Do 17Z-3, flown by vänr. Olli Kepsu, 2/LeLv 46, Linnunniemi landing ground, Finland, February 1942

Finnish bomber units suffered combat losses through the summer and fall of 1941 that they could not replace from local sources. Help came in the form of fifteen Do 17Z aircraft gifted by the Luftwaffe, which was in the process of phasing the type out of service. These aircraft entered Finnish inventory during January and February 1942, and began operational flights from April with LLv 46. Five of the Finnish airframes survived World War Two combat and the last was retired on October 1st, 1952. One of them was coded DN-55, which also was the last Finnish Air Force aircraft to fly a Second World War mission, when it photographed German units on April 4th, 1945, in the vicinity of Kilpisjärvi. The Dorniers reached the Finnish units at the beginning of 1942 camouflaged in RLM 70/71/65, in the same scheme as they were flown by the Luftwaffe. The Finns also used temporary white paint as a winter camouflage, and in the case of DN-55, this paint was applied over the RLM 71 fields.

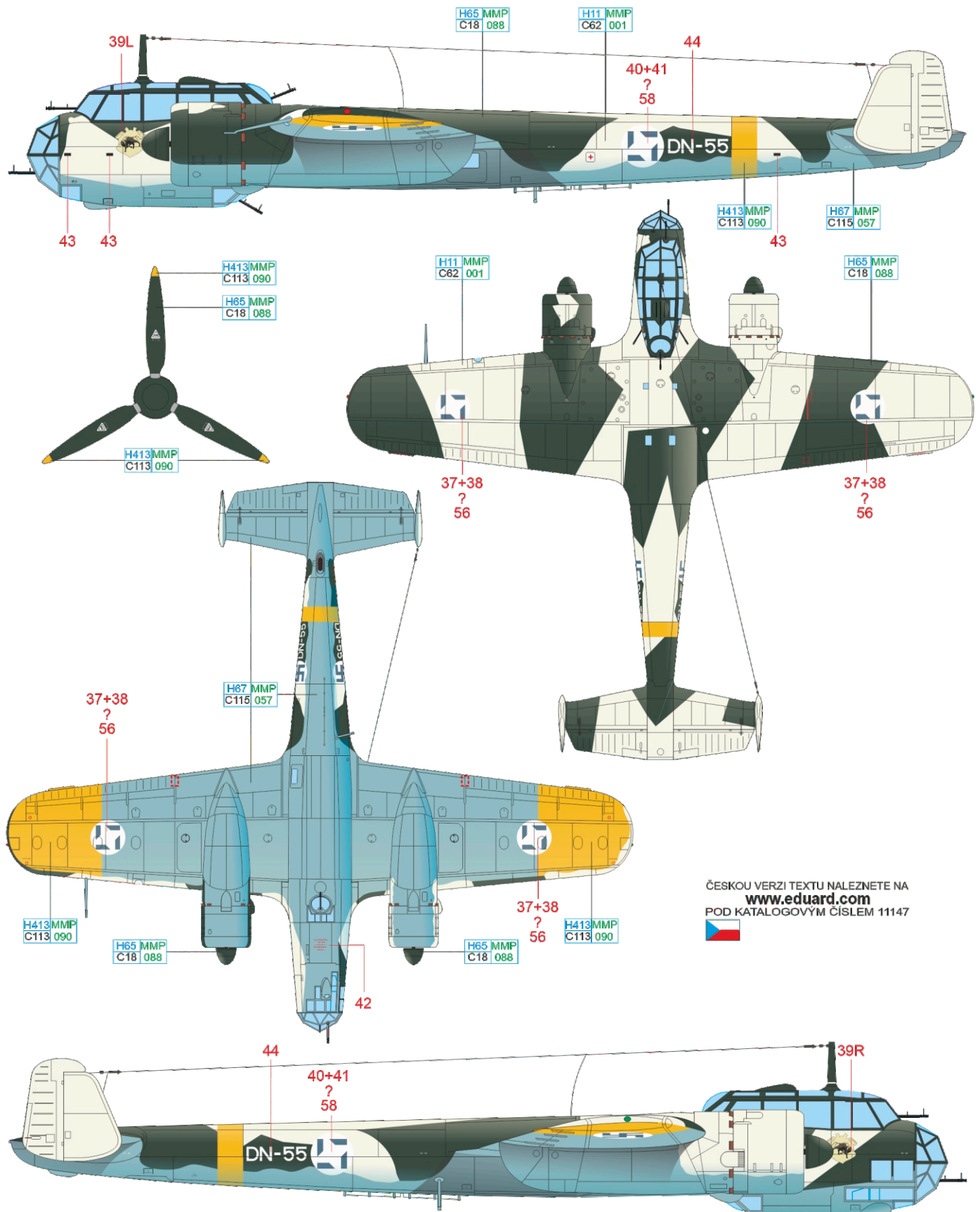

ČESKOU VERZI TEXTU NALEZNETE NA
www.eduard.com
 POD KATALOGOVÝM ČÍSLEM 11147



RLM 65 H67 MMP C115 057 RLM 70 H65 MMP C18 088 WHITE H11 MMP C62 001 RLM 04 H413 MMP C113 090

eduard

