

**eduard**

LIMITED

# the Ultimate **Tempest**

instruction sheet



1/48

11164-NAV1



ATTENTION



UPOZORNĚNÍ



ACHTUNG



ATTENTION



注意



Carefully read instruction sheet before assembling. When you use glue or paint, do not use near open flame and use in well ventilated room. Keep out of reach of small children. Children must not be allowed to suck any part, or pull vinyl bag over the head.



Před započítím stavby si pečlivě prostudujte stavební návod. Při používání barev a lepidel pracujte v dobře větrané místnosti. Lepidla ani barvy nepoužívejte v blízkosti otevřeného ohně. Model není určen malým dětem, mohlo by dojít k požití drobných dílů.

INSTRUCTION SIGNS \* INSTR. SYMBOLS \* INSTRUKTION SINNBILDEN \* SYMBOLES \* 記号の説明

OPTIONAL  
VOLBABEND  
OHNOUTSAND  
BROUSITOPEN HOLE  
VYVRTAT OTVORSYMETRICAL ASSEMBLY  
SYMETRICKÁ MONTÁŽREMOVE  
ODŘÍZNOUTREVERSE SIDE  
OTOČITAPPLY EDUARD MASK  
AND PAINT  
POUŽIT EDUARD MASK  
NABARVIT

PARTS



DÍLY



TEILE



PIÈCES



部品

## PLASTIC PARTS

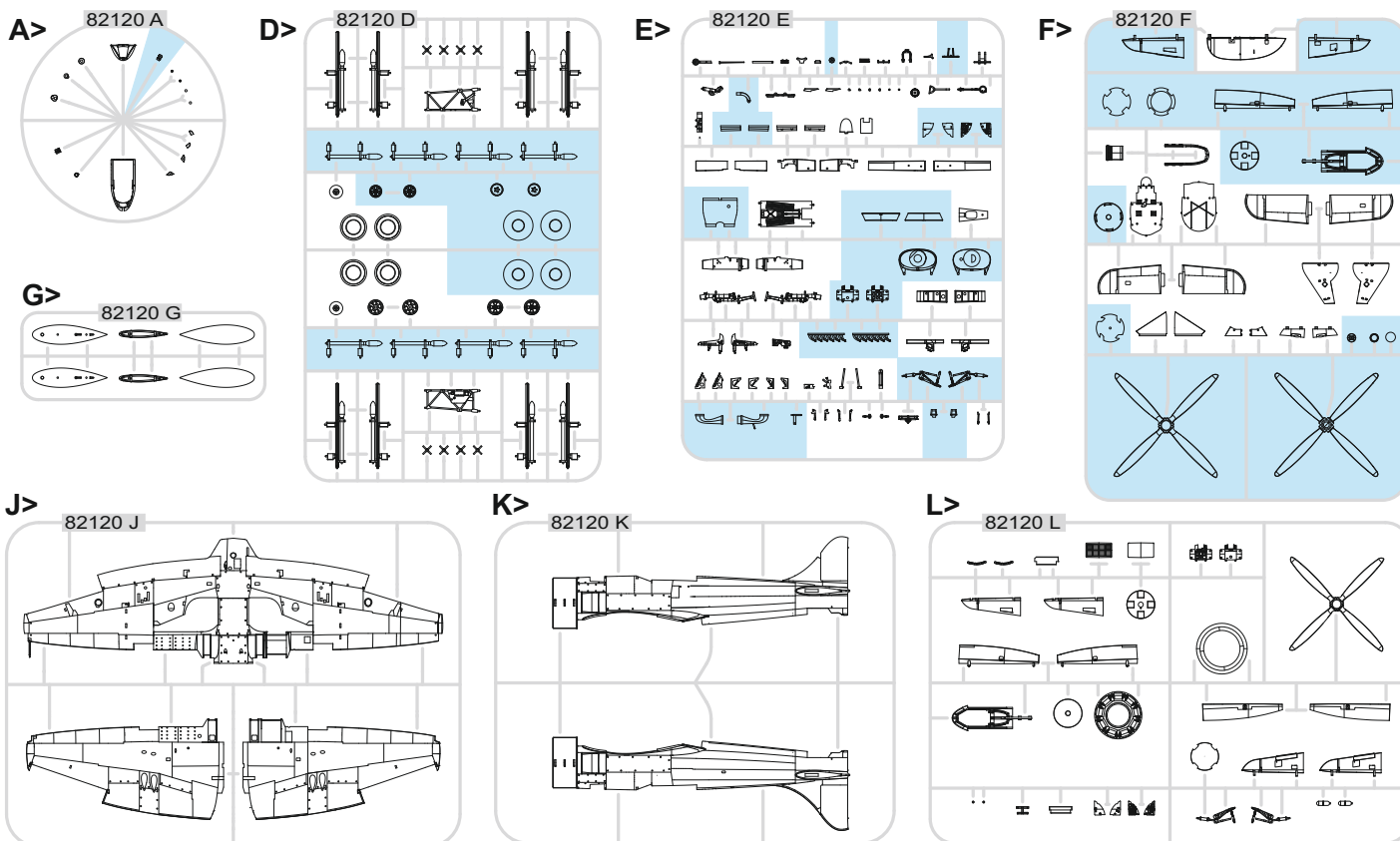
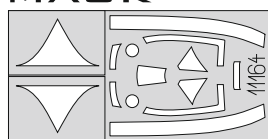
eduard  
MASK

## PE - PHOTO ETCHED DETAIL PARTS

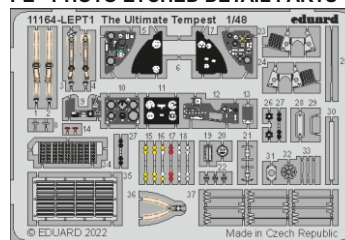

-Parts not for use. -Teile werden nicht verwendet. -Pièces à ne pas utiliser. -Tyto díly nepoužívejte při stavbě. - 使用しない部品

COLOURS



BARVY



FARBEN



PEINTURE



色

GSI Creos (GUNZE)		MISSION MODELS	
AQUEOUS	Mr.COLOR	PAINTS	
H3	C3	MMP-003	RED
H4	C4	MMP-007	YELLOW
H8	C8		SILVER
H11	C62	MMP-001	FLAT WHITE
H12	C33	MMP-047	FLAT BLACK
H52	C12	MMP-091	OLIVE DRAB
H71	C21	MMP-076	MIDDLE STONE
H72	C369	MMP-078	DARK EARTH
H74	C368	MMP-080	SKY
H77	C137	MMP-040	TIRE BLACK
H90	C47		CLEAR RED
H94	C138		CLEAR GREEN
H307	C307	MMP-074	GRAY

GSI Creos (GUNZE)		MISSION MODELS	
AQUEOUS	Mr.COLOR	PAINTS	
H328	C328		BLUE
H330	C361	MMP-077	DARK GREEN
H335	C363	MMP-094	MEDIUM SEAGRAY
	C74	MMP-061	AIR SUPERIORITY BLUE
	C362		OCEAN GRAY
	C364	MMP-079	AIRCRAFT GRAY-GREEN
	C370	MMP-092	AZURE BLUE
Mr.METAL COLOR		METALLICS	
MC213		MMM-006	STEEL
MC214		MMM-001	DARK IRON
MC218		MMM-003	ALUMINIUM
Mr.COLOR SUPER METALLIC		METALLICS	
SM201		MMC-001	SUPER FINE SILVER



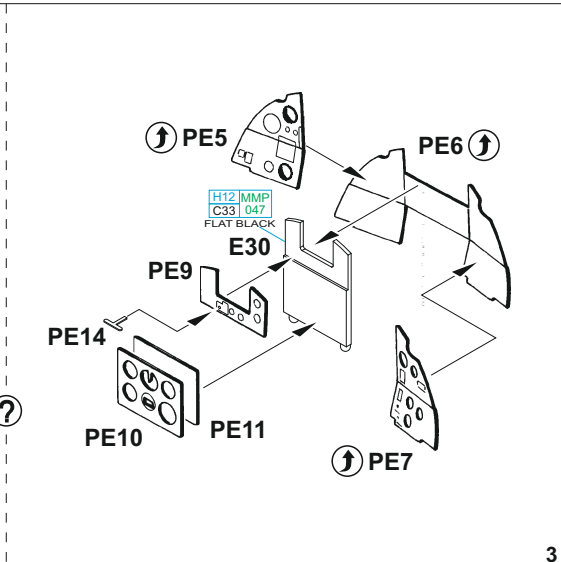
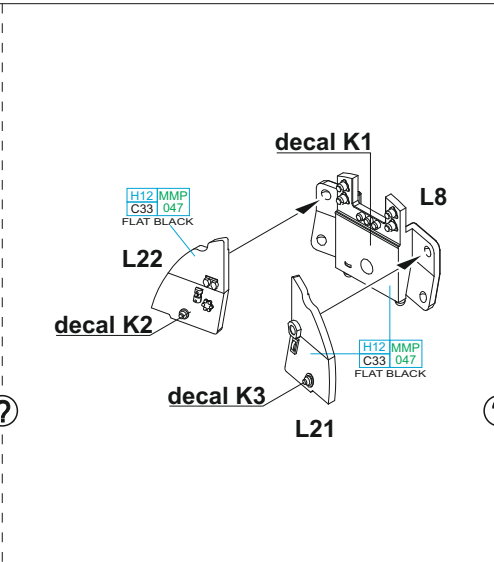
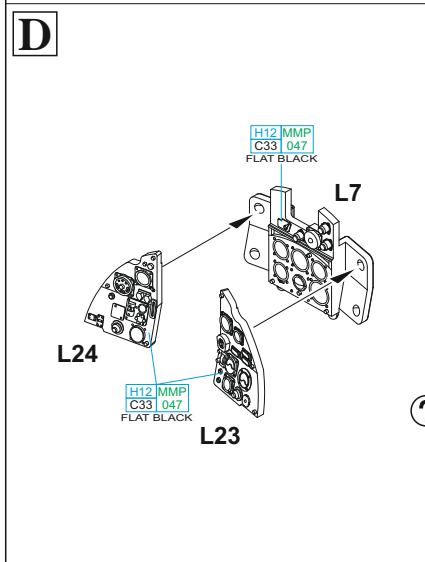
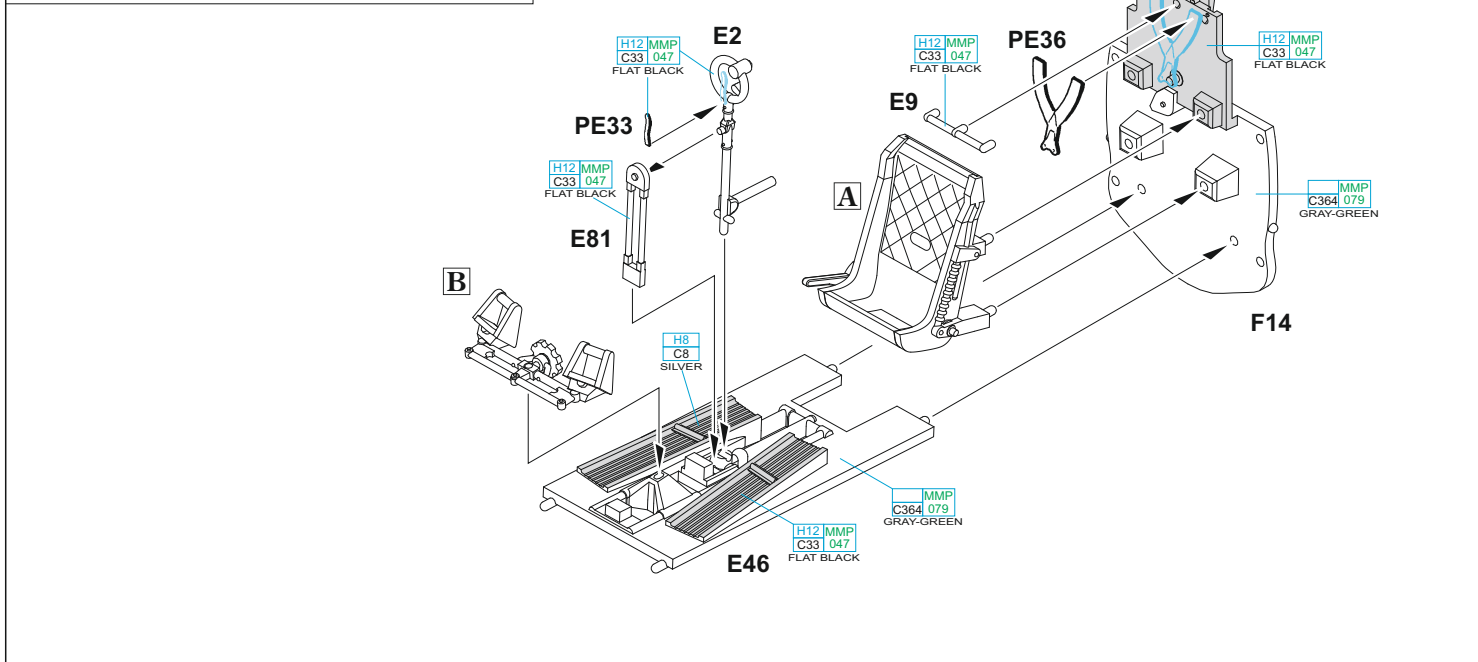
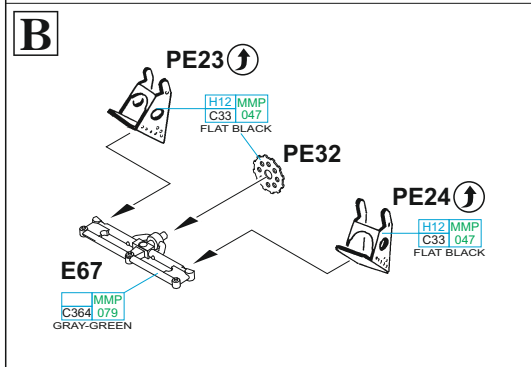
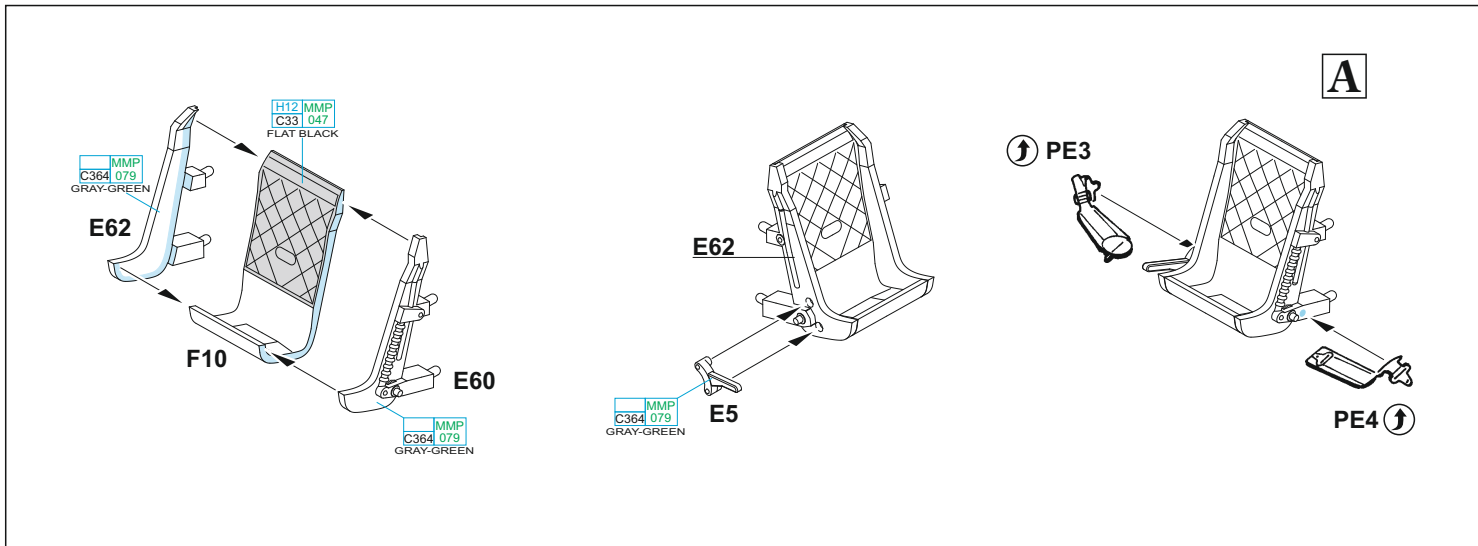



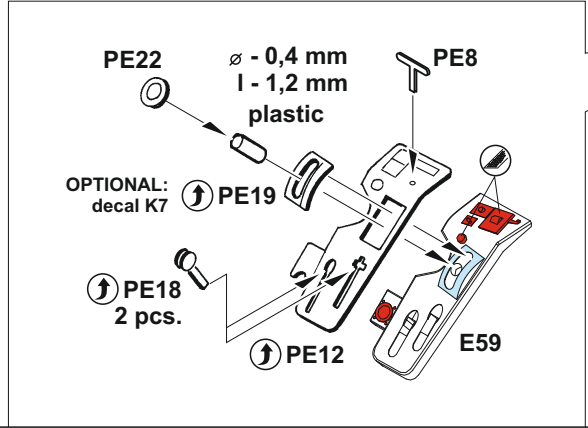
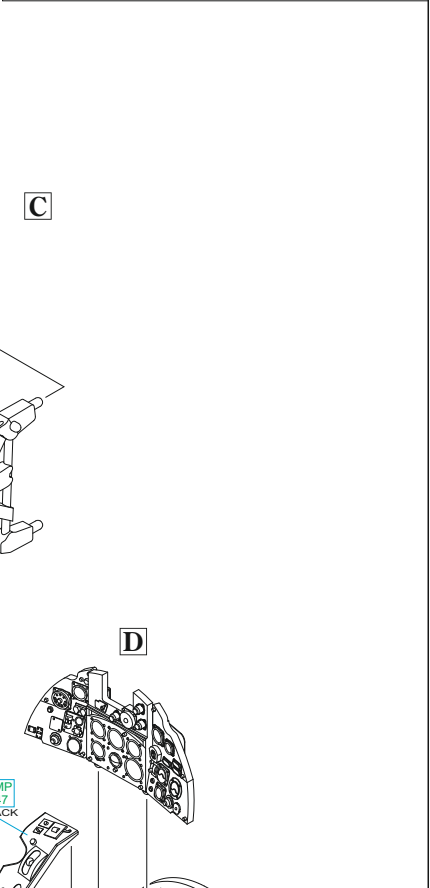
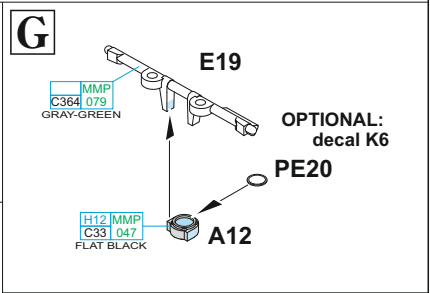
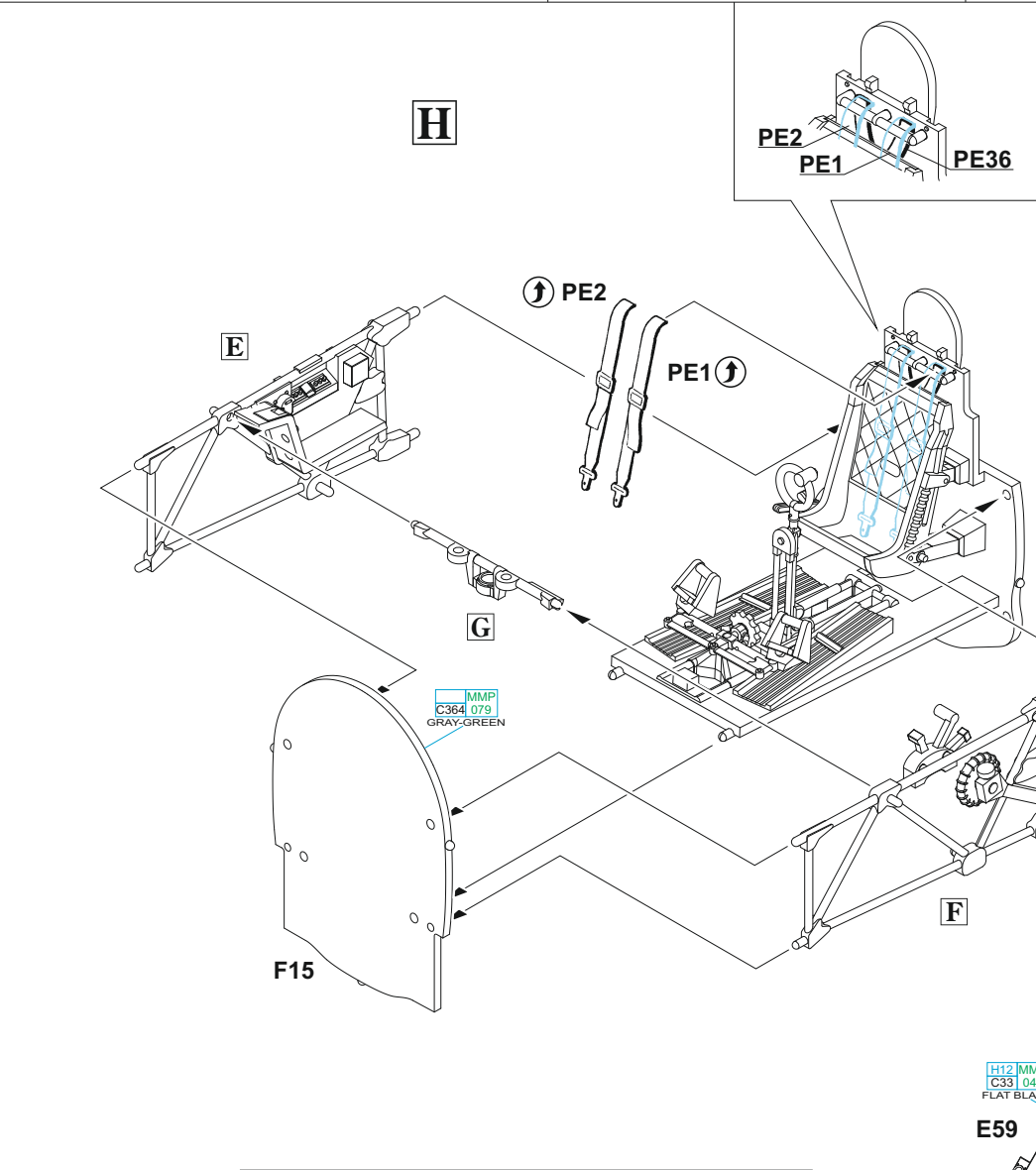
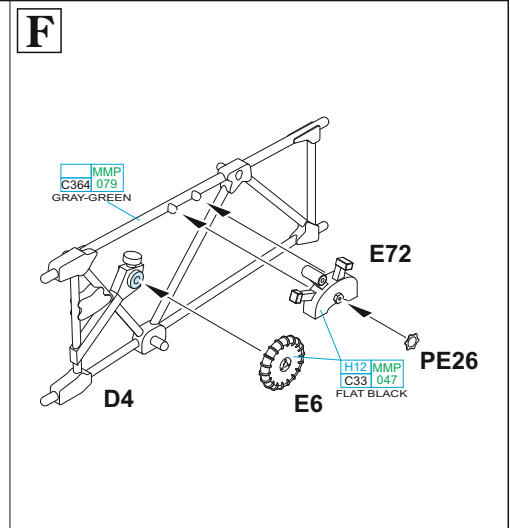
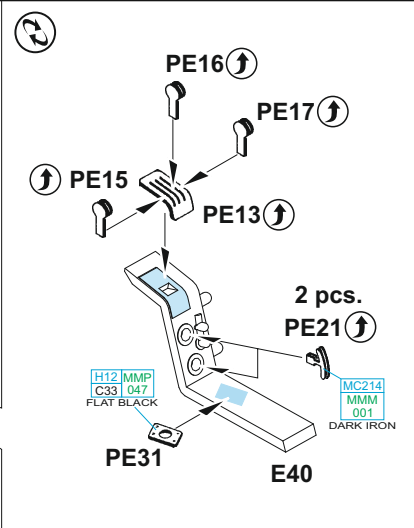
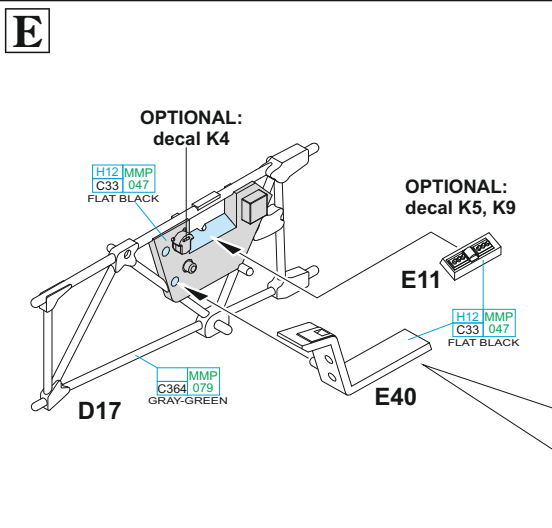

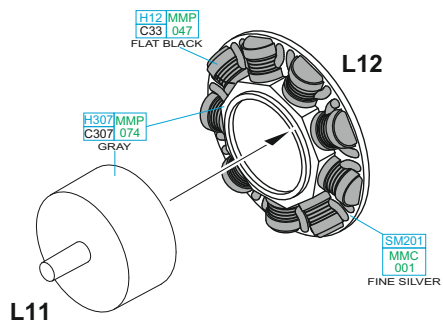
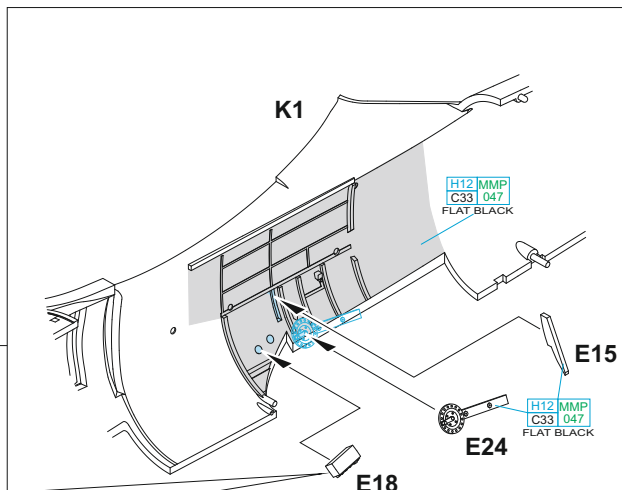
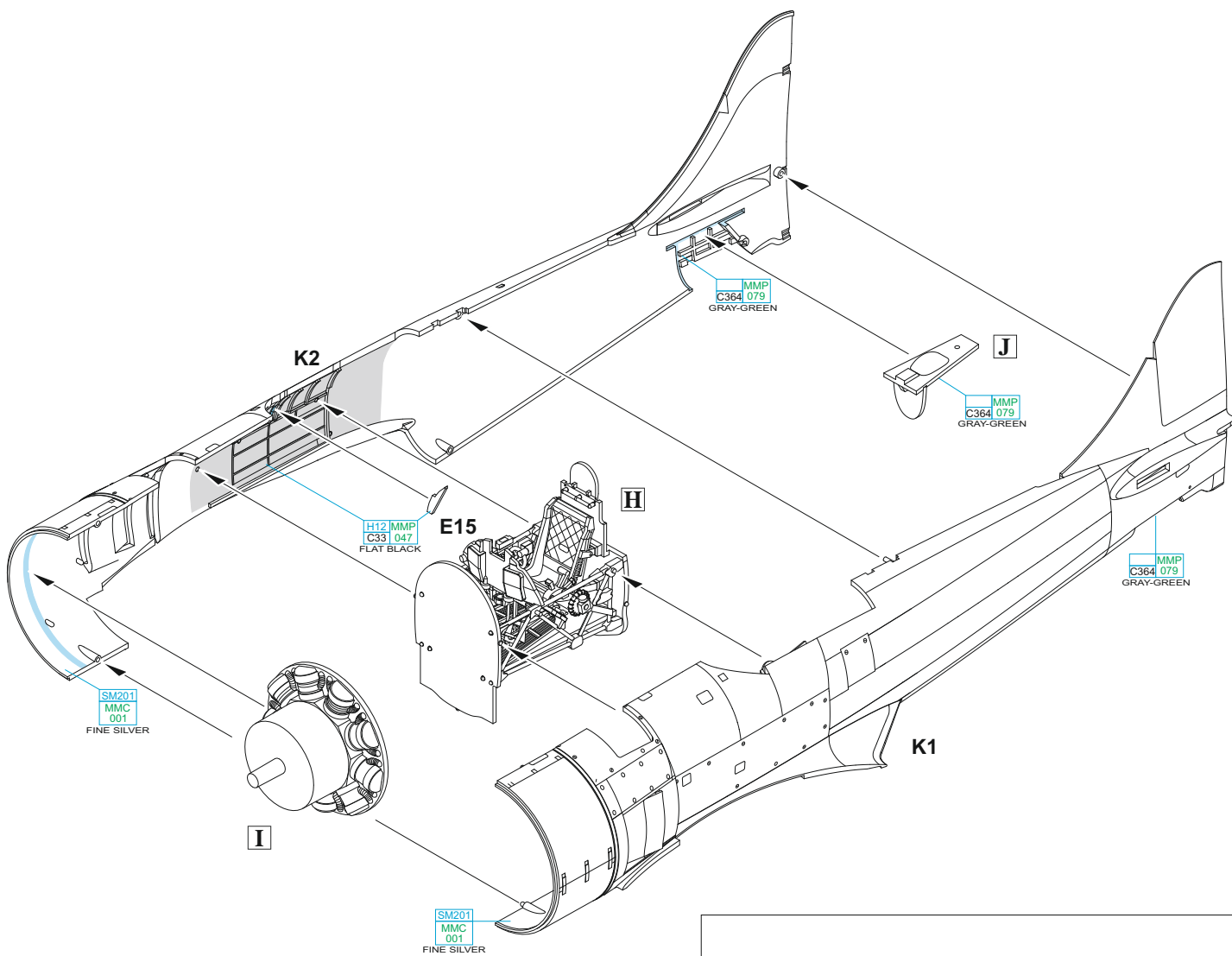
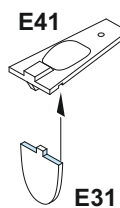

**I****J**

OPTIONAL:  
decal K8

**E18**



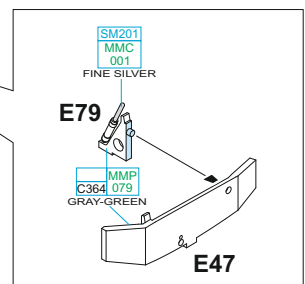
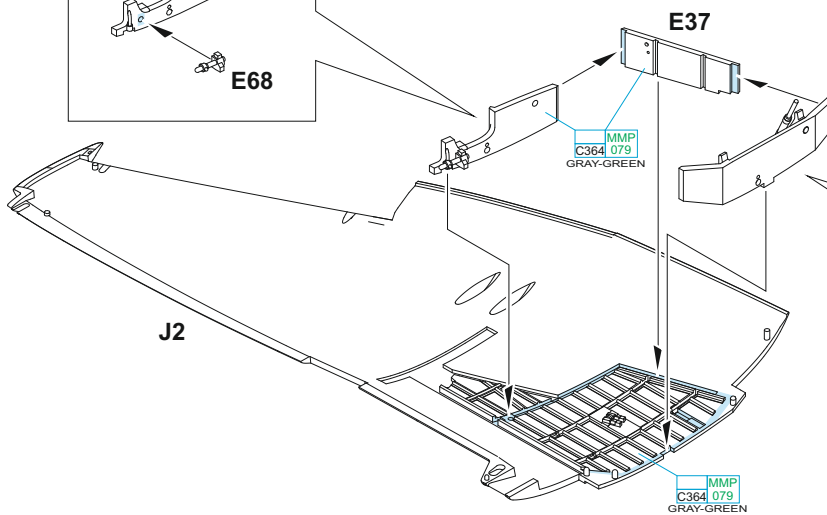
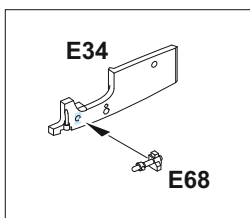
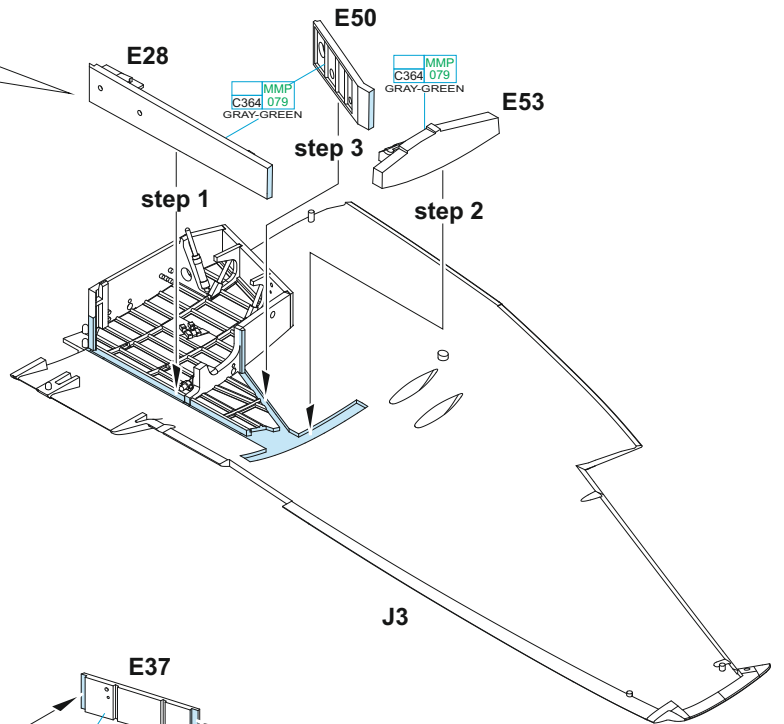
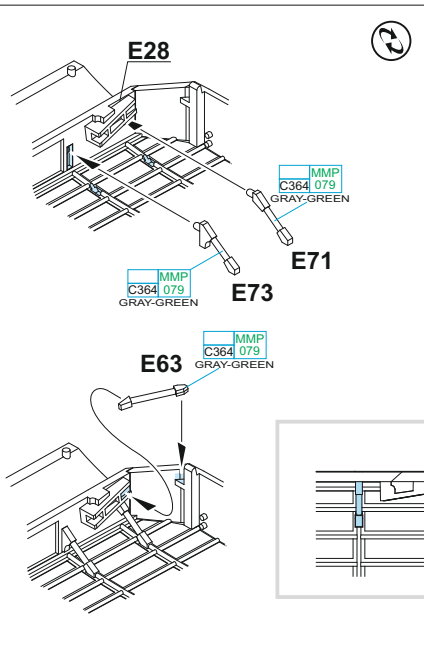
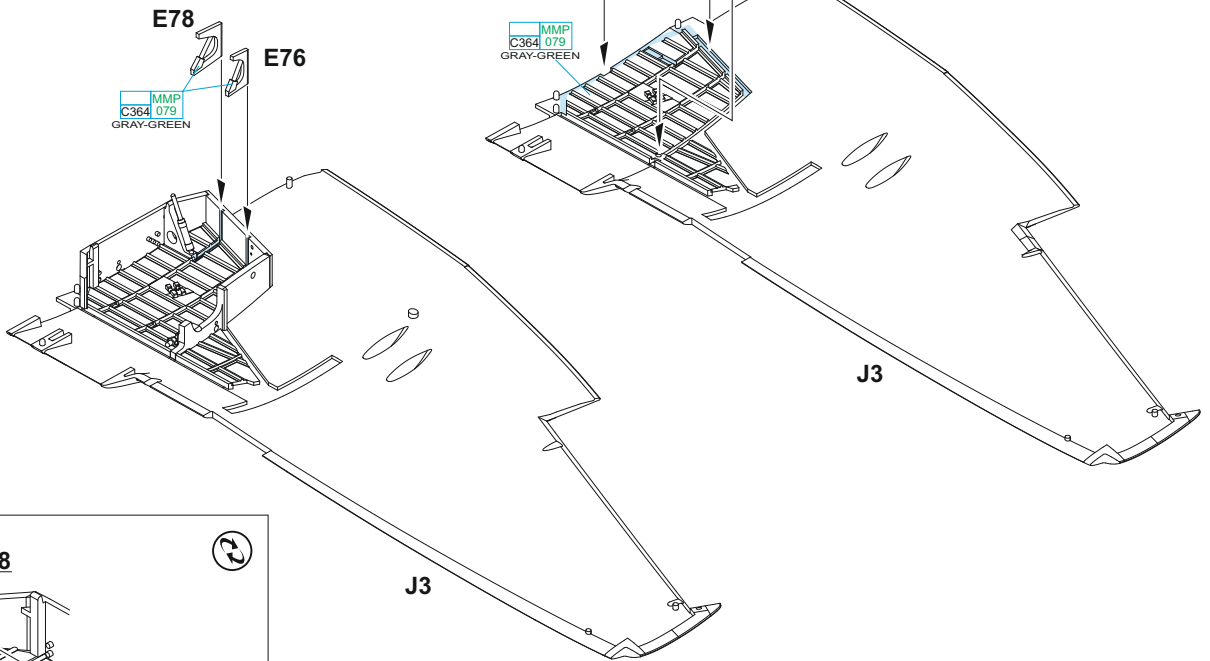
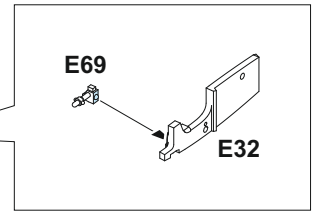
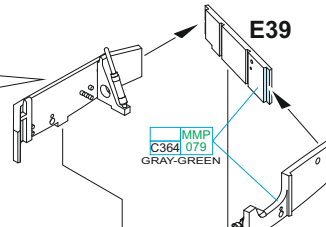
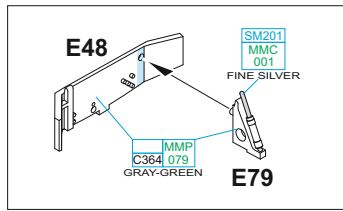

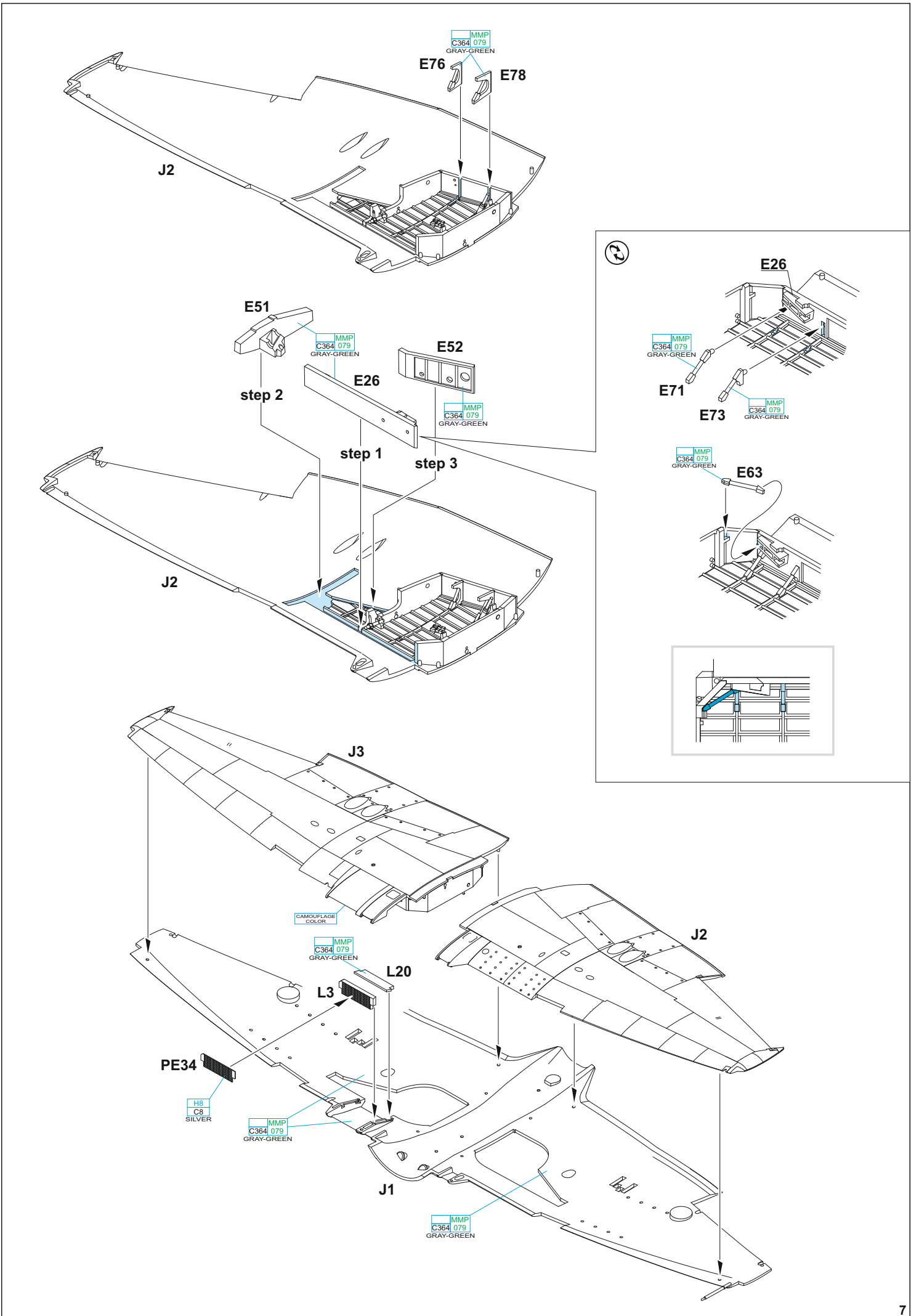



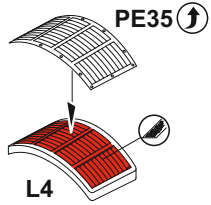

L4 - MARKINGS **D, E, F, G, H, I, J**  
L5 - MARKINGS **A, B, C**

L5 ? L4

H12 MMP  
C33 047  
FLAT BLACK

E74

E16

H12 MMP  
C33 047  
FLAT BLACK

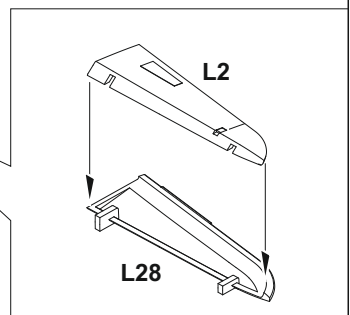
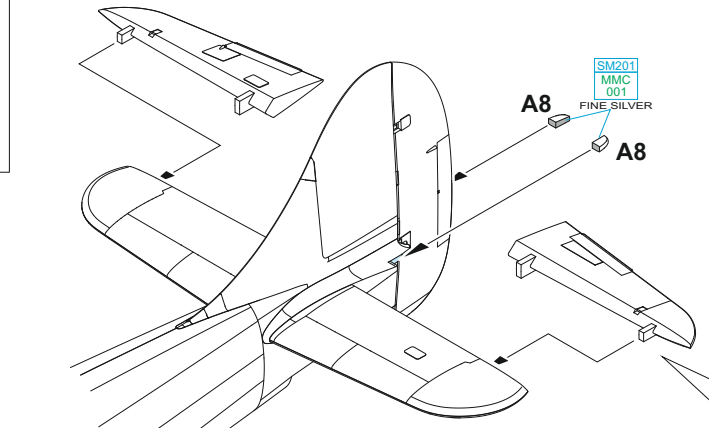
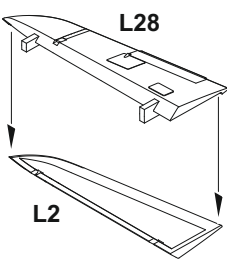
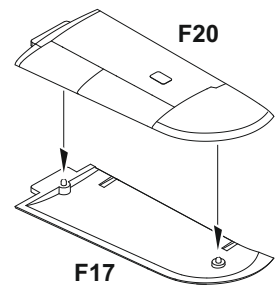
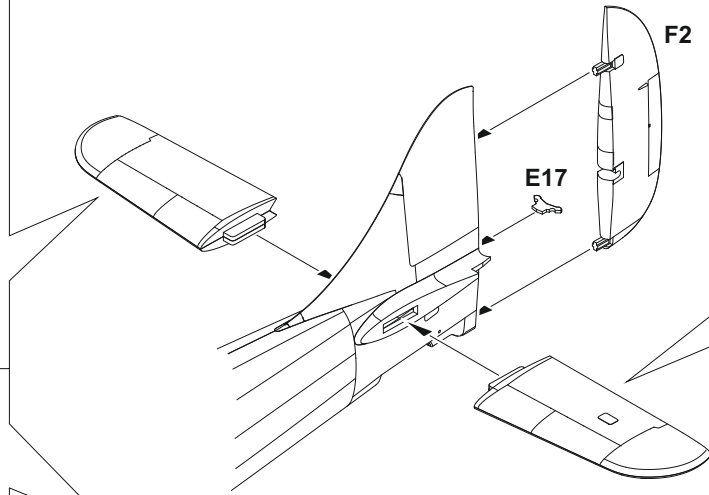
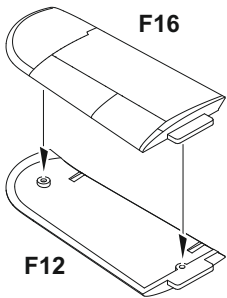
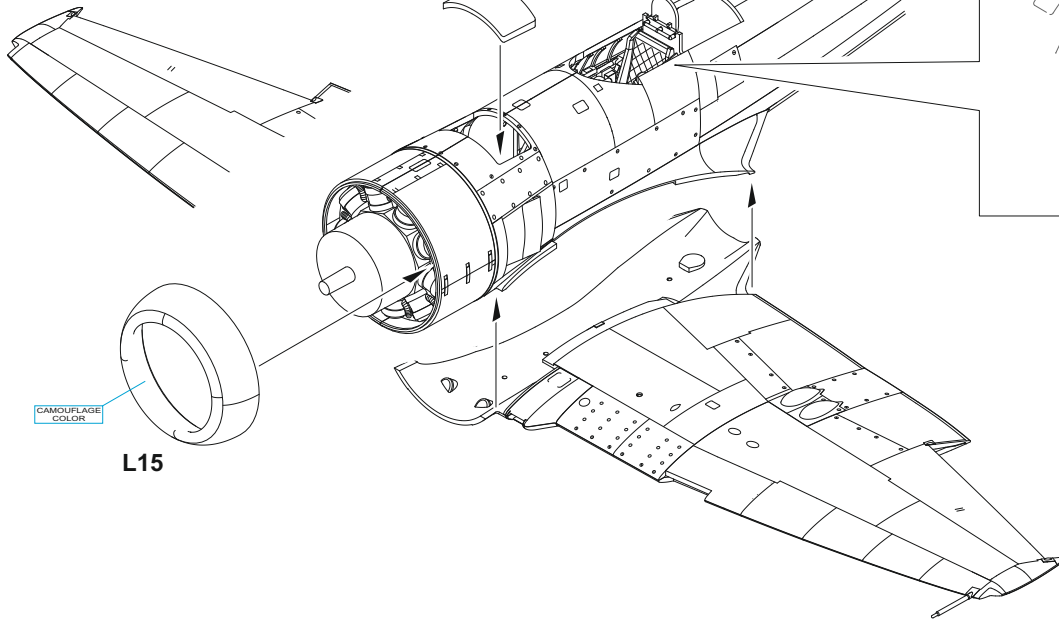

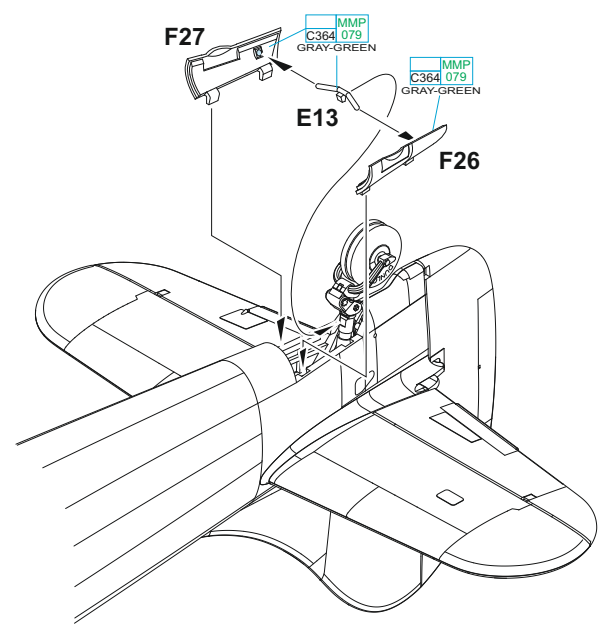
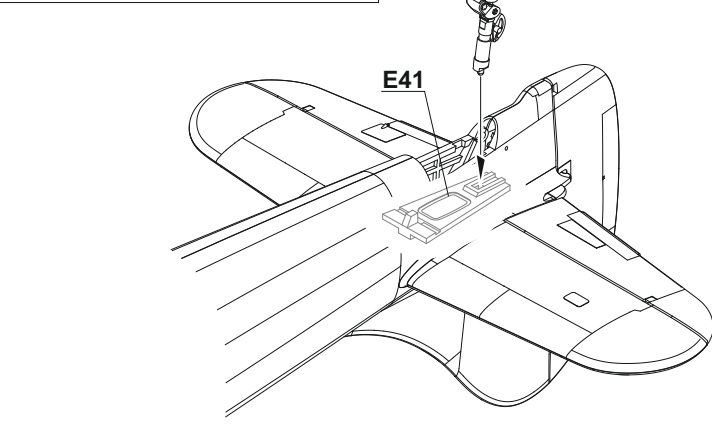
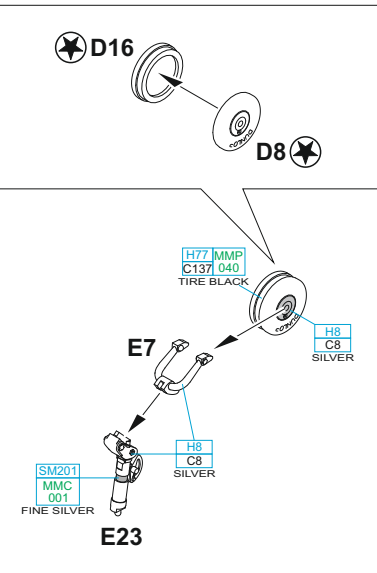
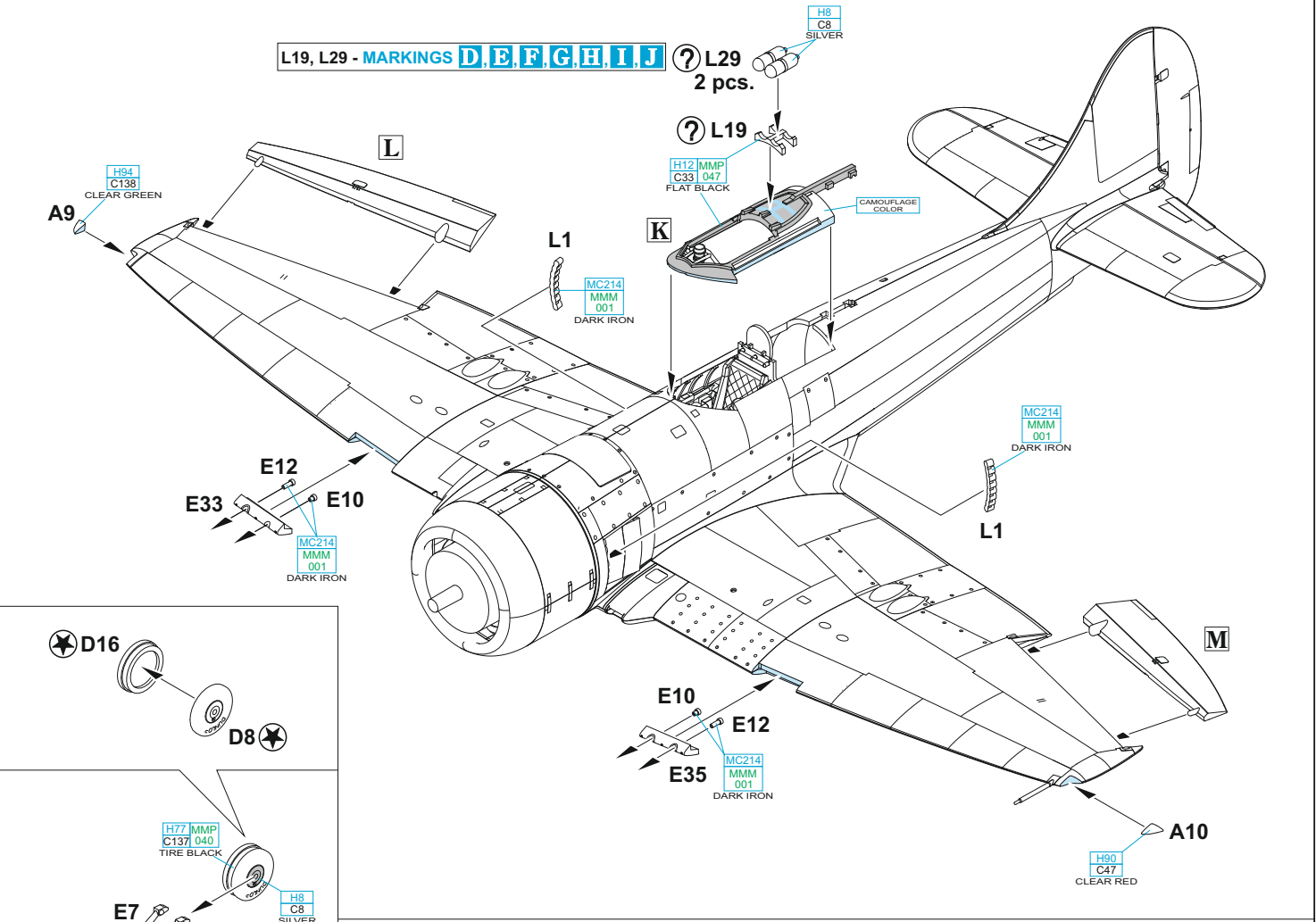
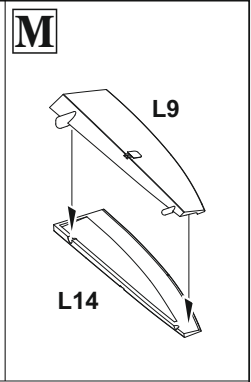
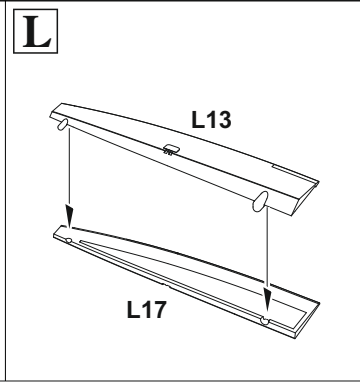
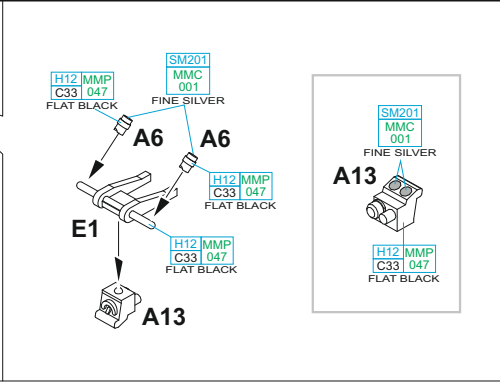
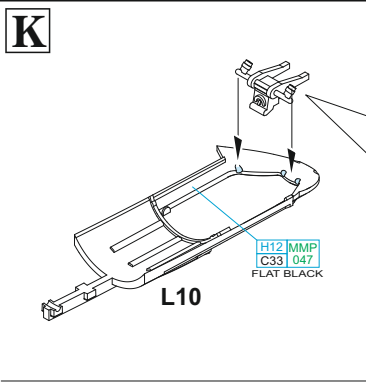



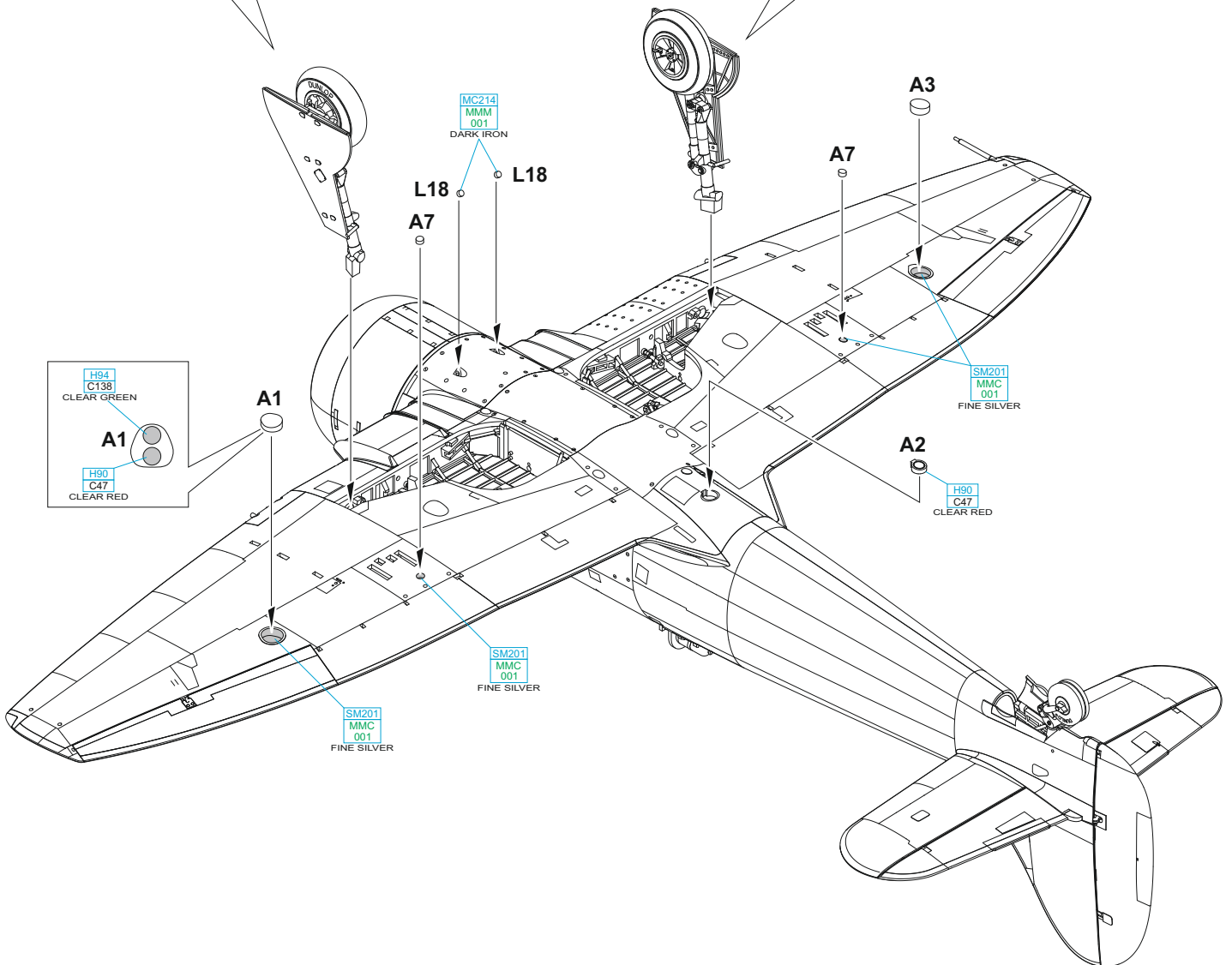
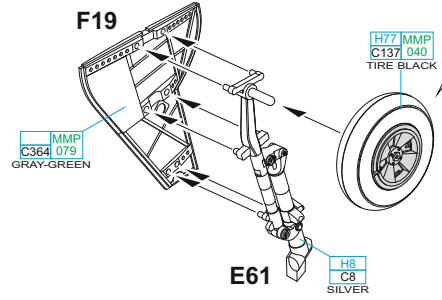
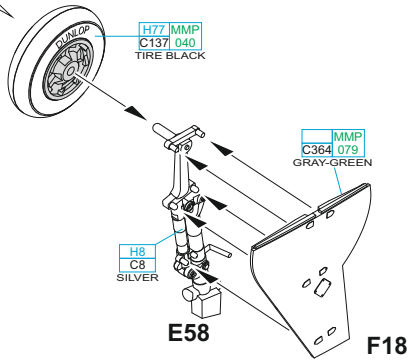
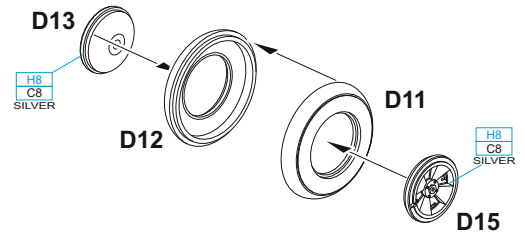
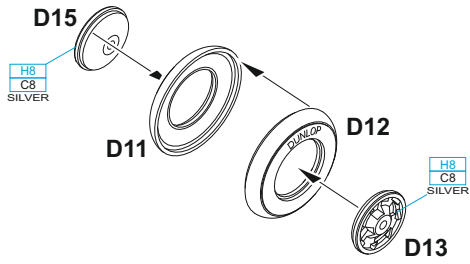

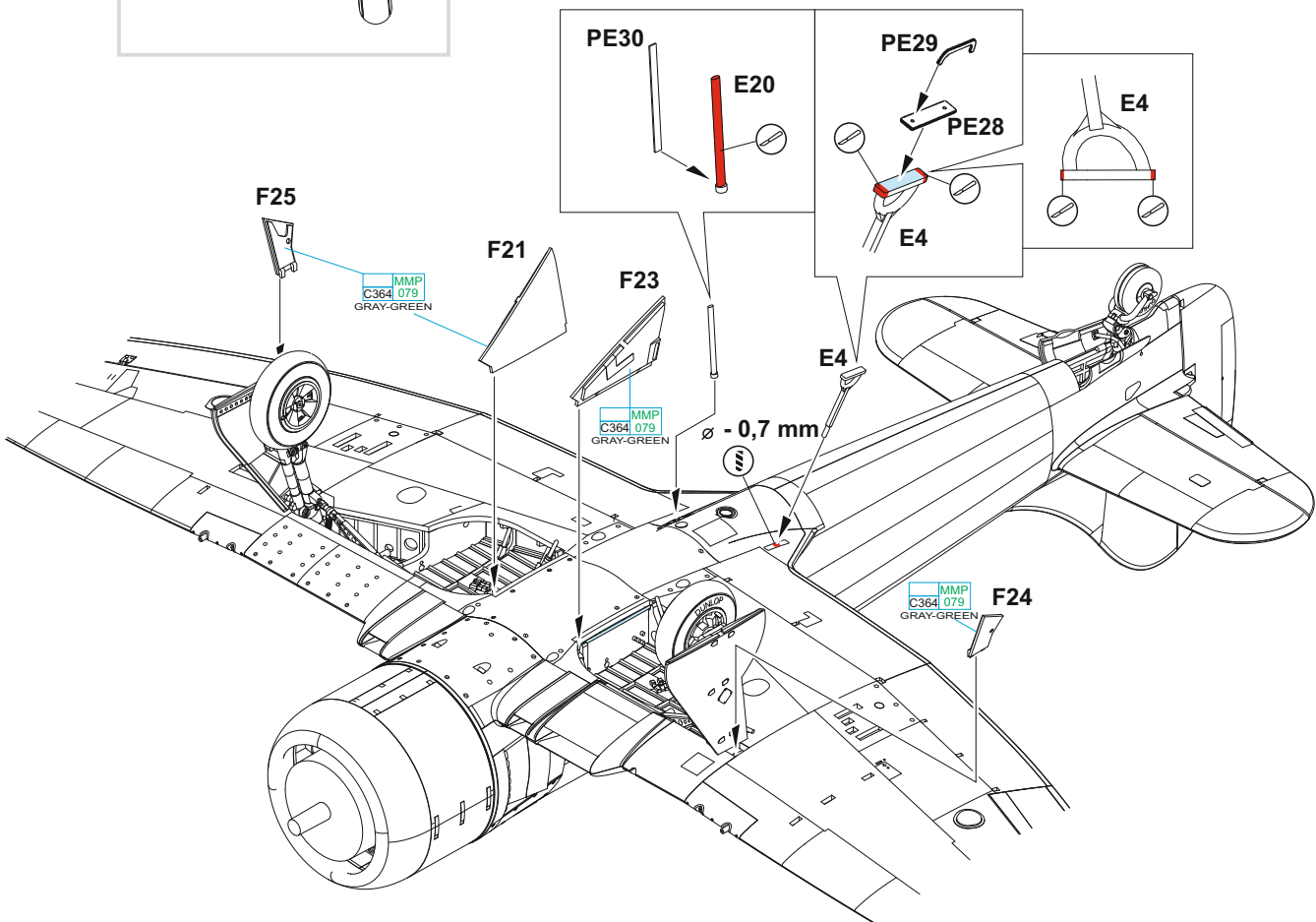
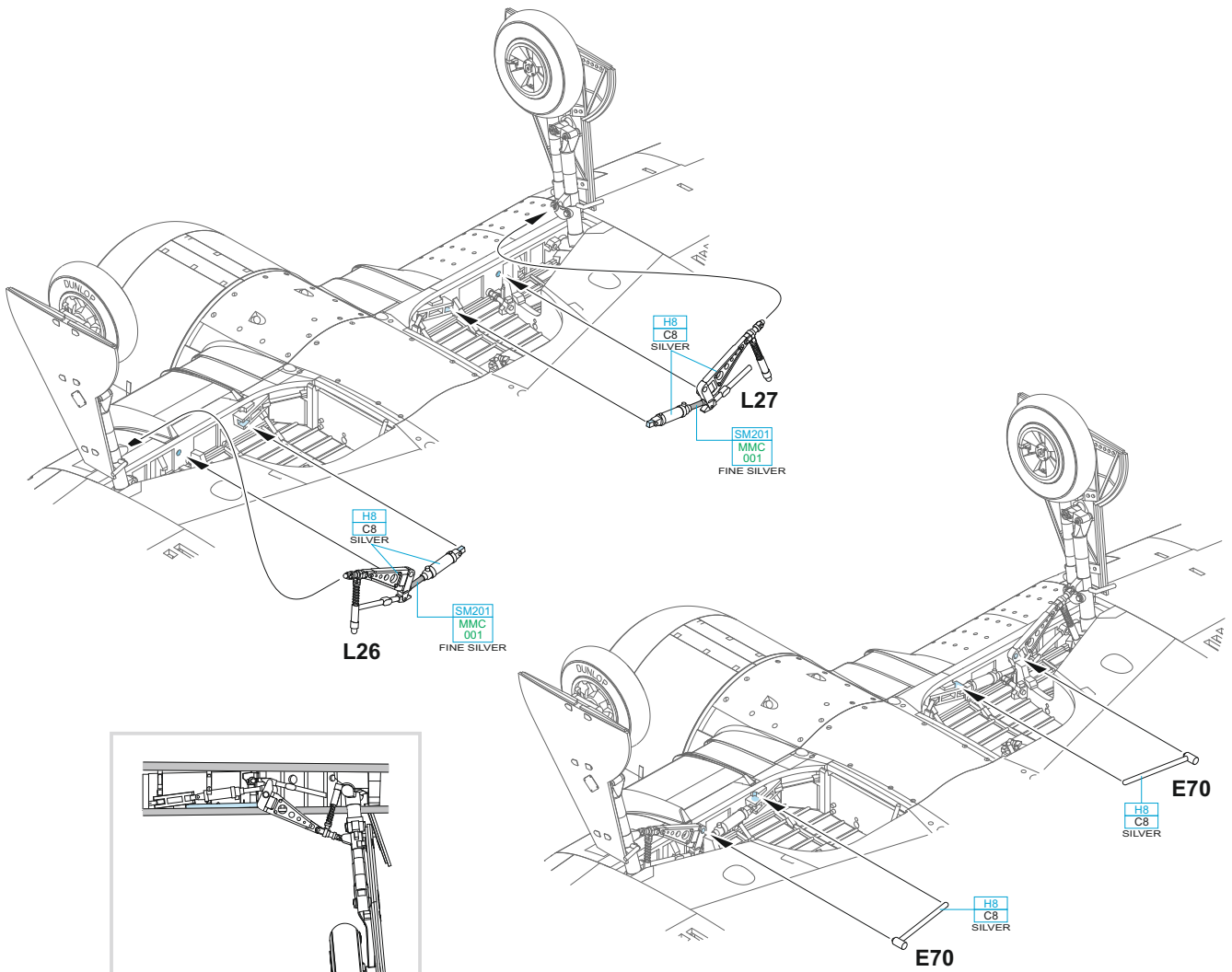

**N**

H12 MMP  
C33 047  
FLAT BLACK

**F11**

H12 MMP  
C33 047  
FLAT BLACK

**A11** 

**PE25**

**E22** 

**CLOSED CANOPY**

**N**

**A4** 

H12 MMP  
C33 047  
FLAT BLACK

**decal S42**

**E8**

**?**

**OPEN CANOPY**

**N**

**L6**

**L25**

**L16**

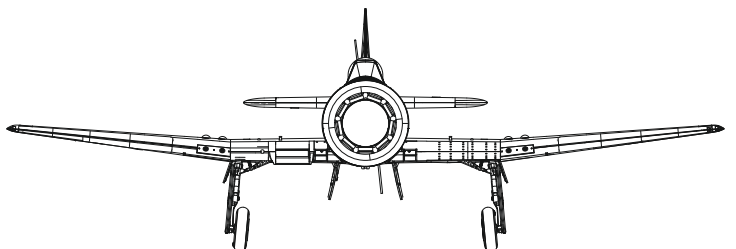
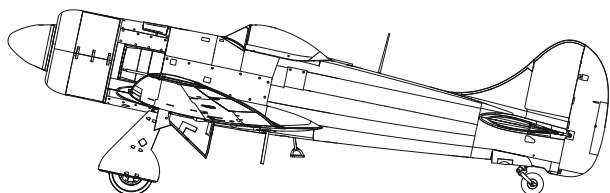



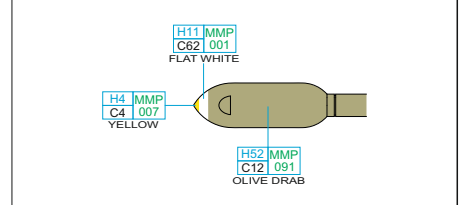
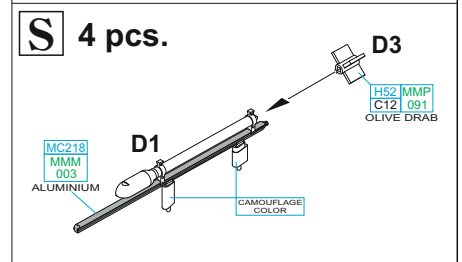
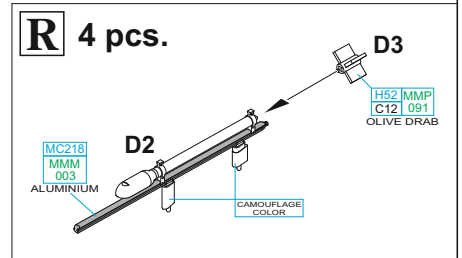
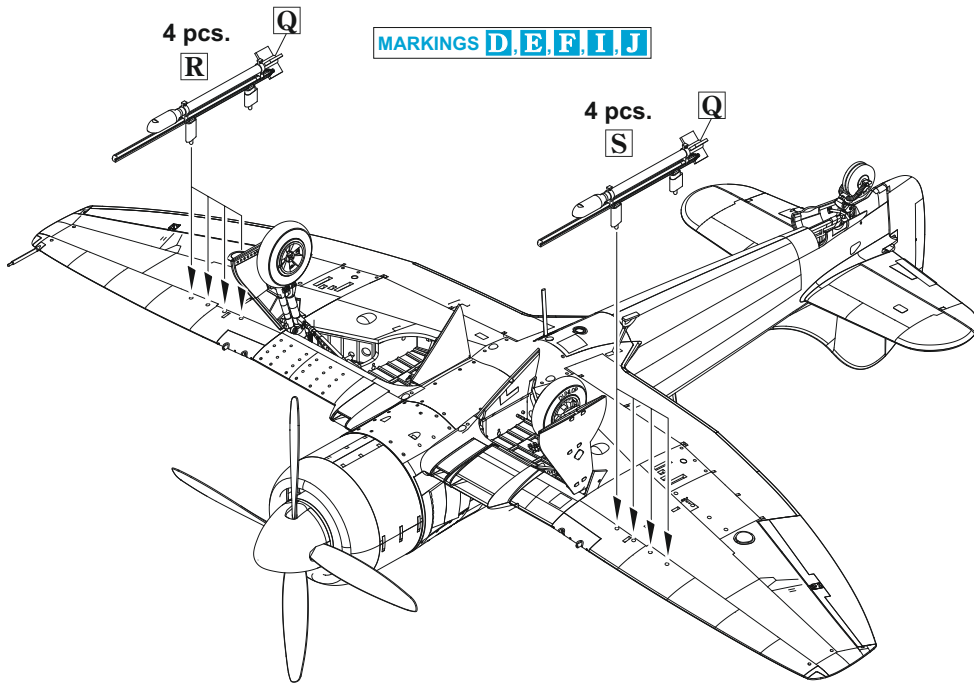
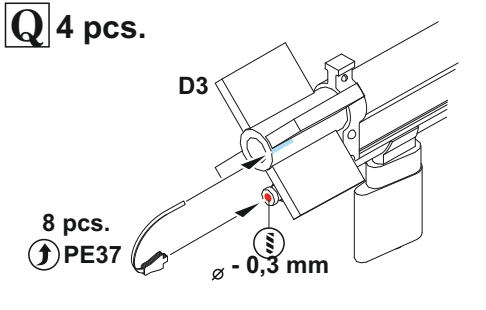
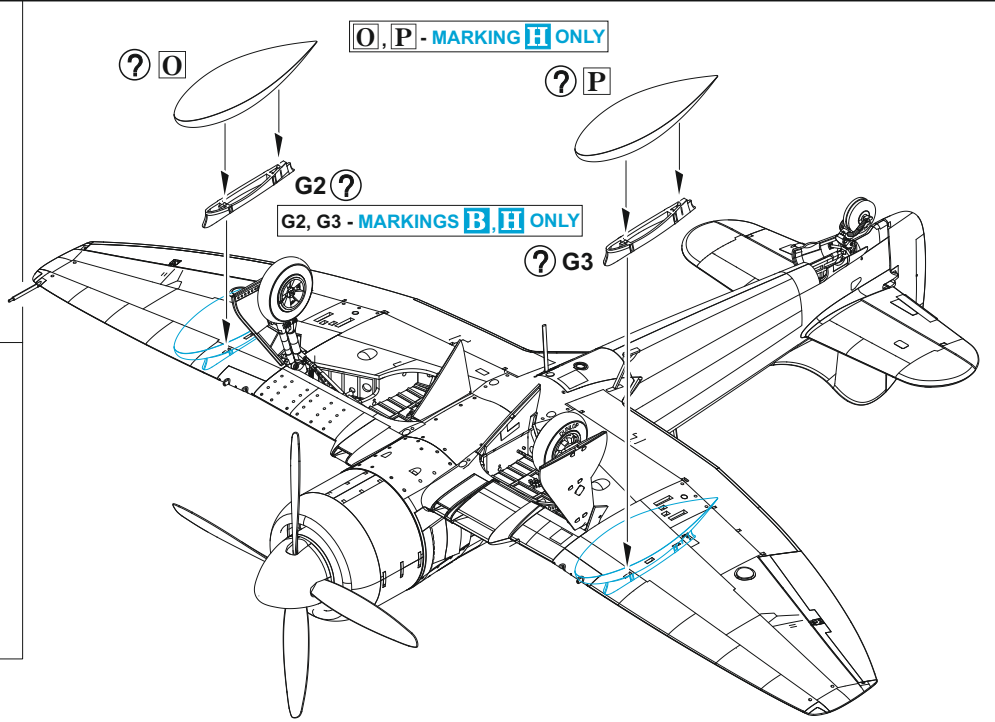
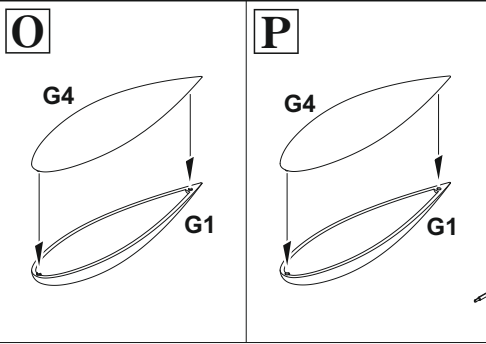

**eduard**  
**MASK**  
**11164**

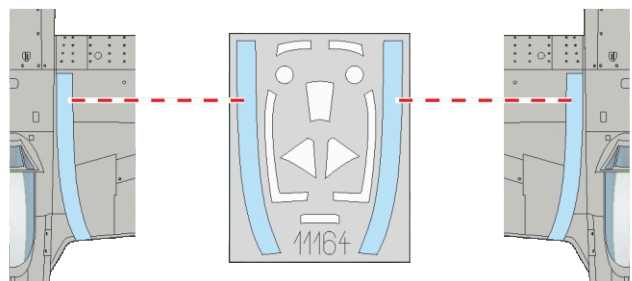
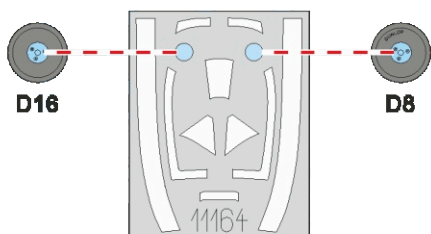
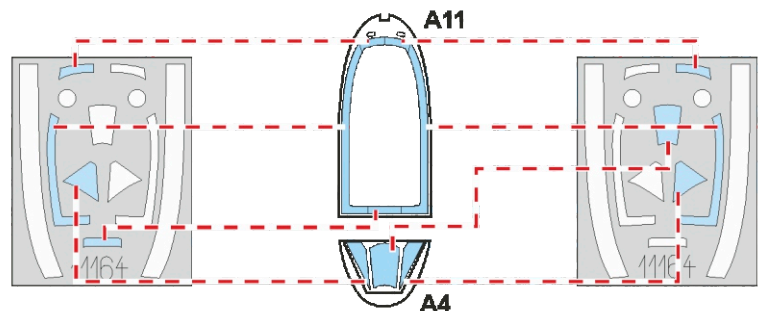

# A MW835, W/Cdr Charles H. Dyson, CO of Southern Sector, RAF Middle Wallop, Hampshire, Great Britain, 1946

After W/Cdr Roland Beamont the new Southern Sector commander became Charles „Deadstick“ Dyson who had his leader’s MW835 repainted with his initials „C-D“ and add to the marking the unusually gaudy red and yellow lightning on the both sides of the fuselage. The lightning was partially deleted and only the red nose with red chevrons on the sides remained. Black and white propeller spinner was probably the remainder of the original scheme. From the period photograph we can determine that the MW835 landing gear covers on both sides were either replaced or repainted as the corresponding part of the wing codes on the lower wing surfaces is missing.

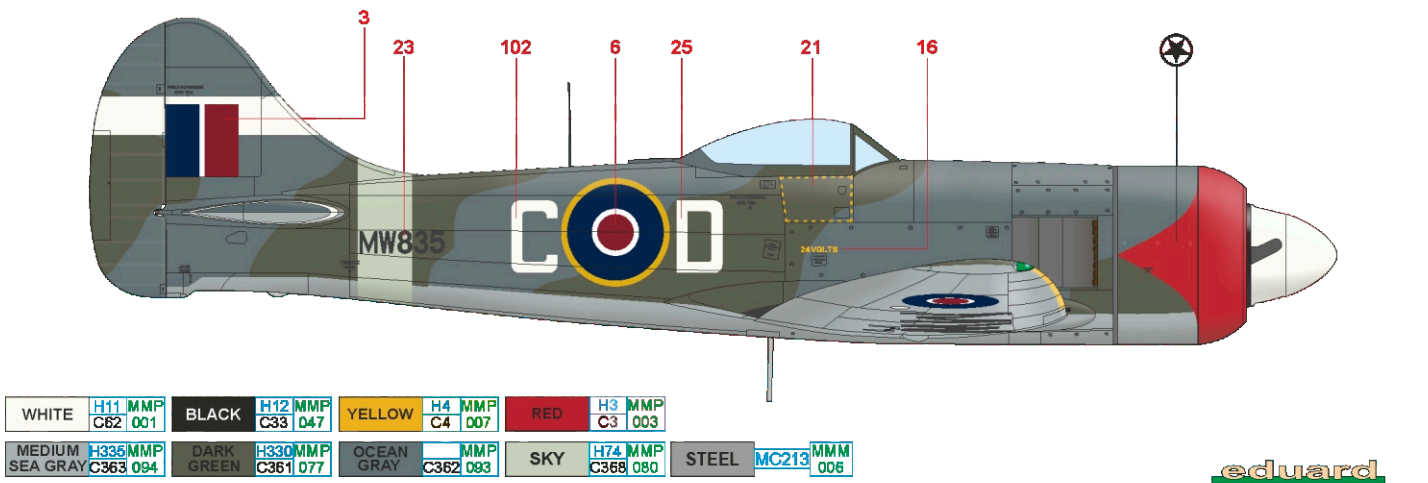
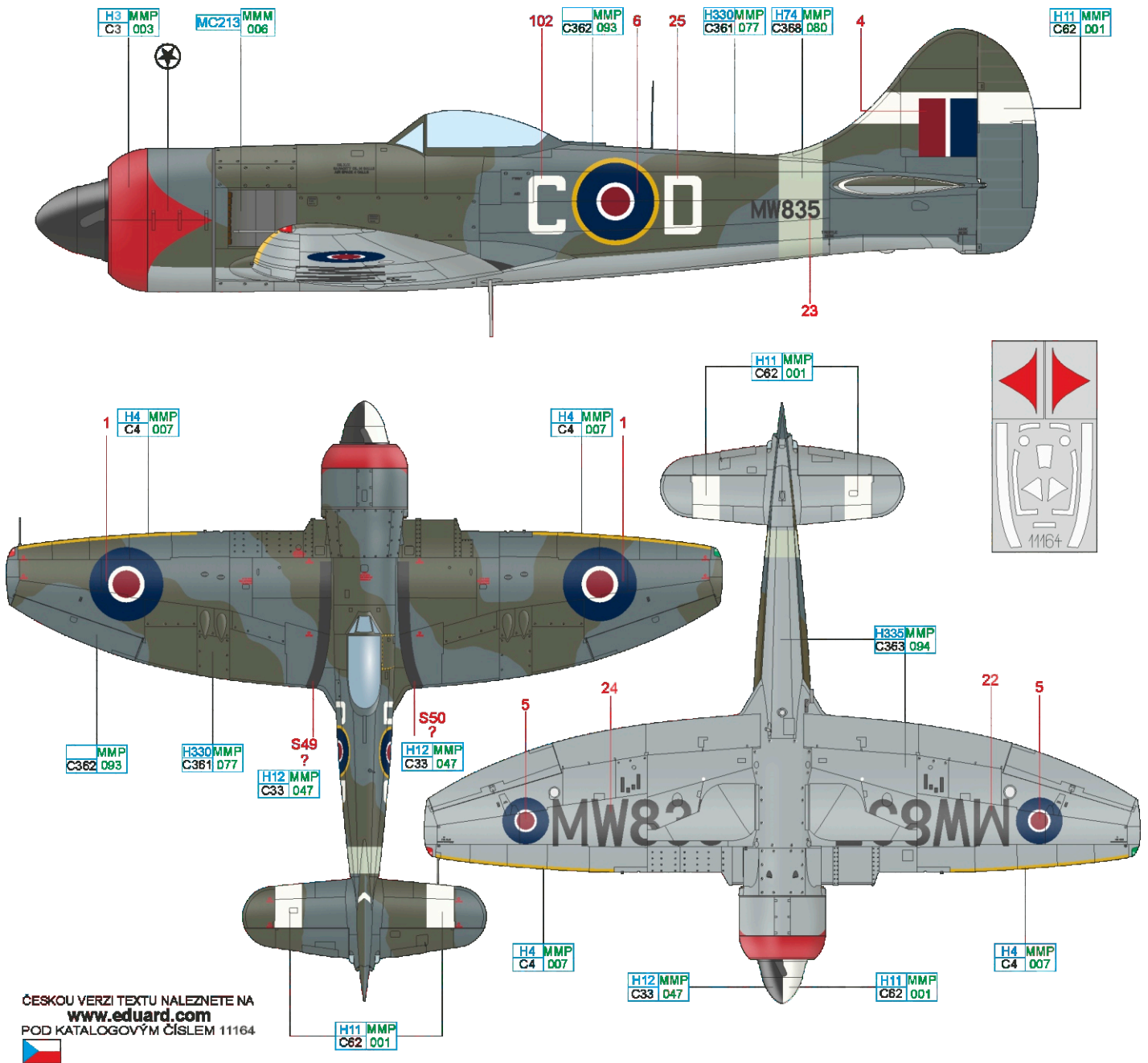

# B MW800, S/Ldr Frank W. M. Jensen, CO of No. 54 Squadron, RAF Chilbolton, Hampshire, Great Britain, June 1946

During the Victory Flight Parade, which took place on June 8, 1946 over London, No. 54 Squadron was led by S/Ldr Frank Jensen in his personal Tempest Mk.II within the Fighter Command therefore they were located on the Great Britain's territory. The aircraft carried the standard camouflage in Ocean Grey and Dark Green colors on the upper surfaces and Medium Sea Gray on the lower surfaces. The band on the rear fuselage and code letters were painted Sky. The Jensen's aircraft carried the squadron commander pennant under the windshield. The photograph confirms that the left landing gear covers was probably a replacement from another Tempest.

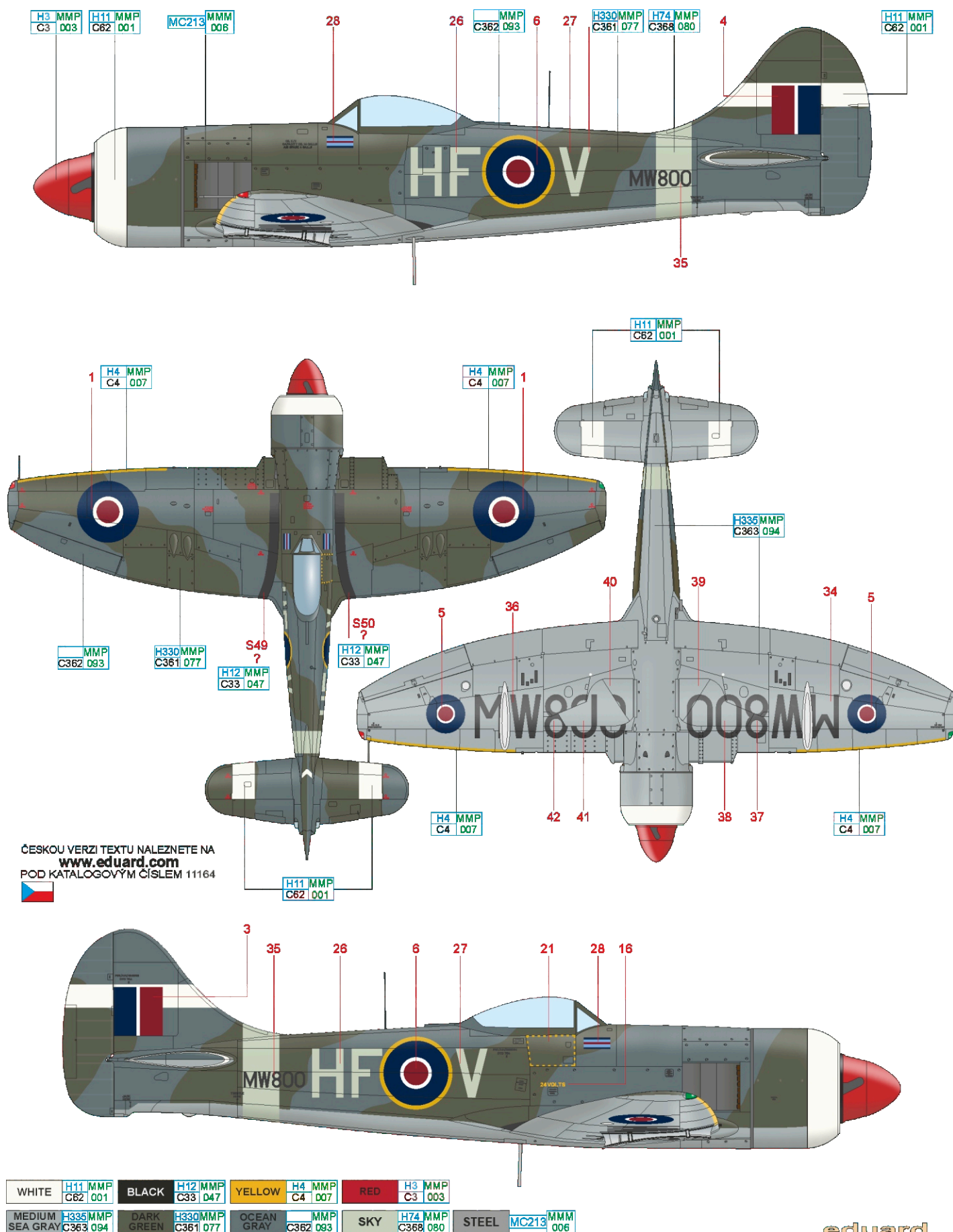



The first Tempests that arrived in India in the end of June 1945 were PR256 and PR527. They sported the Day Fighter Scheme with at that time applicable combat identification of the fighters operating in ACSEA area – the white propeller spinner as well as white serial number and stripes on the wings, horizontal and vertical tail surfaces. The smaller and modified national insignia were painted in the combination of dark and light blue color. From January 1947 the aircraft flew at the research and development aviation Chakeri. Eight months later it was handed over to the Royal Indian Air Force (RIAF) which operated it in this markings except of the national markings which were replaced with the pre-war RAF insignia.

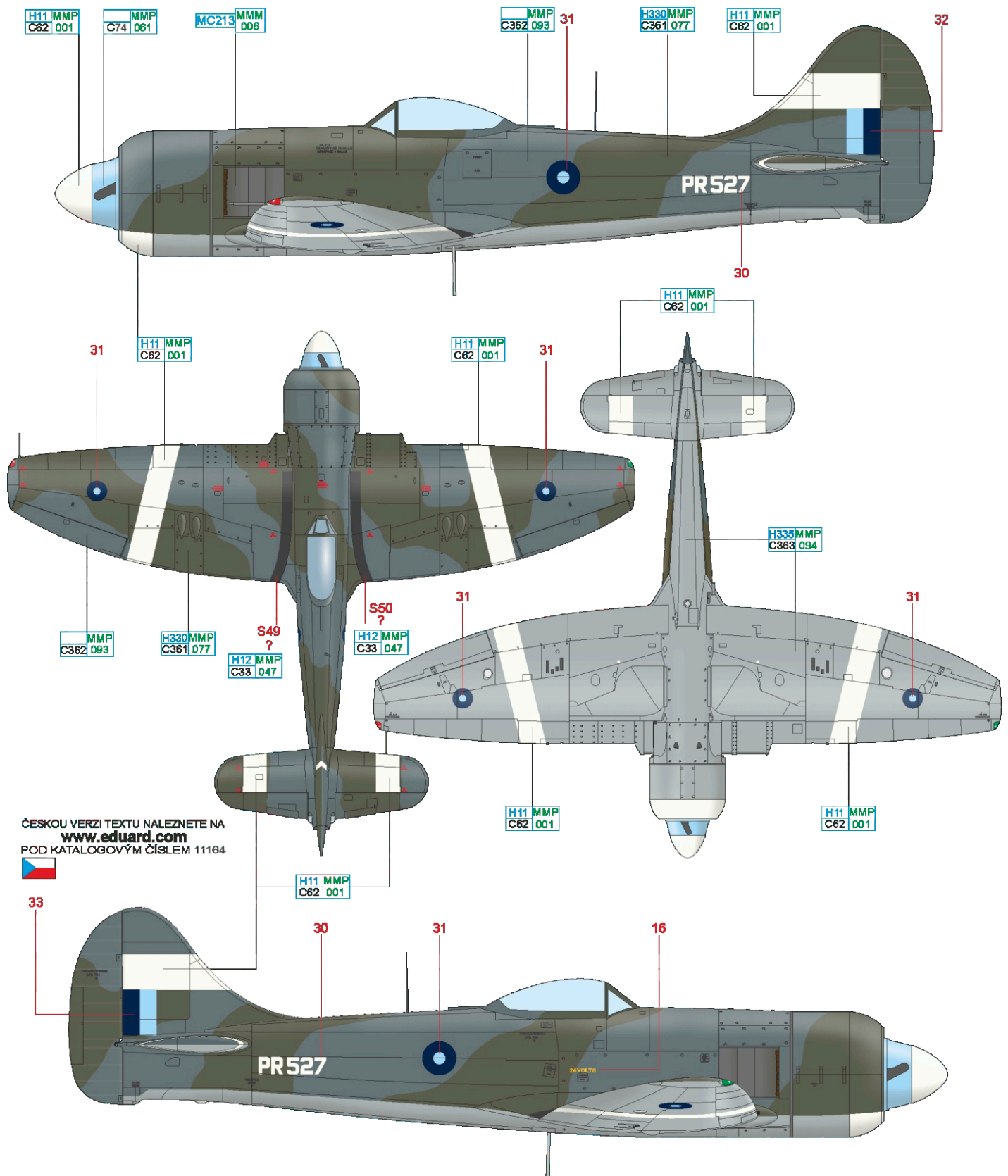

ČESKOU VERZI TEXTU NALEZNETE NA  
[www.eduard.com](http://www.eduard.com)  
 POD KATALOGOVÝM ČÍSLEM 11164



STEEL	MC213	MMM	006																							
MEDIUM SEA GRAY	H335	MMP	C363	094	DARK GREEN	H330	MMP	C361	077	OCEAN GRAY	MMP	C362	093	WHITE	H11	MMP	C62	001	LIGHT BLUE	C74	061	BLACK	H12	MMP	C33	047



# E PR788, S/Ldr R. N. G. Allen, No. 33 Squadron, Kuala Lumpur, Malaysia, February 1948

After WWII No. 33 Squadron first operated in Germany from where it was in the beginning of June 1949 dispatched on board of HMS Ocean to the Far East where it operated until 1970. Until 1960 it flew combat sorties against the communist guerilla forces in Malaysia. It was also the last RAF operational unit flying Tempests Mk.II. The last missions were flown on June 6, 1951, after that the unit started to re-equip with De Havilland Hornet F.3. In the end of February 1948, S/Ldr R. N. G. Allen led the formation of four Tempests from No.33 Squadron to the RAF base Thorney Island where they stayed a week to perform demonstrations for the School of Ground and Air Warfare in Old Sarum. For that occasion S/Ldr Allen's aircraft PR788 coded 5R-A received a shading to it's coding. The letter A was repeated under the nose on black outlined white circle. Under the standard conditions the letter would be black but on this commander's aircraft the upper half of the letter A was painted red, same as the propeller spinner of the A flight, while the bottom half was blue, same as the flight B propeller spinner.

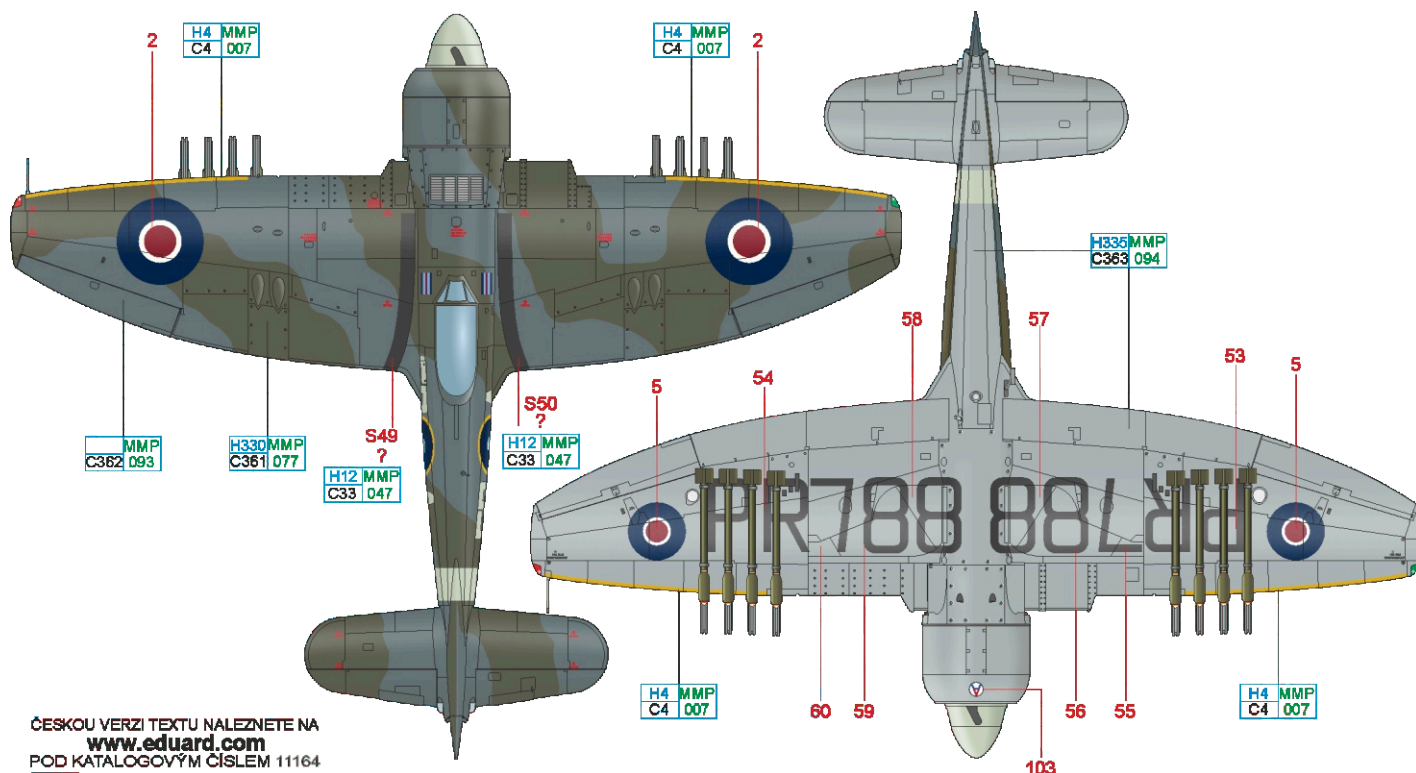
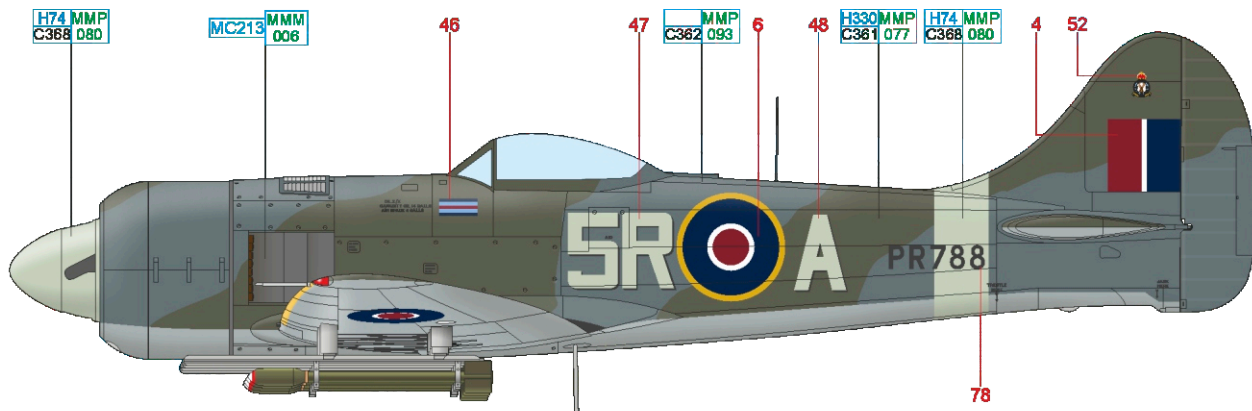

ČESKOU VERZI TEXTU NALEZNETE NA  
[www.eduard.com](http://www.eduard.com)  
 POD KATALOGOVÝM ČÍSLEM 11164

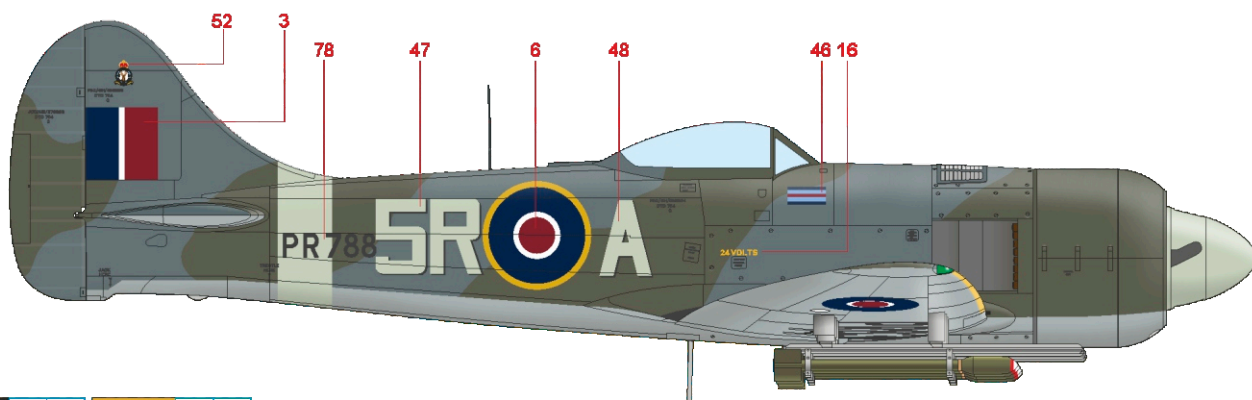

BLACK	H12 MMP C33 047	YELLOW	H4 MMP C4 007
MEDIUM SEA GRAY	H335 MMP C363 094	DARK GREEN	H330 MMP C361 077
	OCEAN GRAY	MMP C362 093	SKY
		H74 MMP C368 080	STEEL
		MC213 MMM 006	



# F PR674, W/Cdr Frank R. Carrey, CO of No. 135 Wing, BAFO, Fassberg, Germany, August 1948 – February 1949

Tempest Mk. II PR674 with black codes FR-C was a personal aircraft of the No. 135 Wing commander, W/Cdr Frank Reginald Carrey. Before that it was flown by W/Cdr J. W. E. Holmes. Frank Carrey enlisted in the RAF in September 1927 and in 1935 he was accepted into pilot training. In September 1936 he was ordered to No. 43 Squadron flying the Fury biplanes. Carrey was selected for the flight's aerobatic team and performed at many air shows. In the beginning of 1939 No. 43 Squadron was re-equipped with Hurricanes and after the outbreak of war Carrey scored his first three shared kills. On May 10 he was ordered to No. 3 Squadron with which he took part in the Battle of France and Battle of Britain. In the end of 1941, as a No. 135 Squadron commander, he was dispatched to Rangoon in the Far East and in February 1942 he assumed command of the No. 267 Wing. In the end of 1943 he stopped flying combat and worked in India at the Air Fighting Training Unit. In November 1944 he was promoted and left for Egypt to No. 73 OTU. In June 1945 he returned to Europe and was put in command of the No. 135 Wing in Germany. He held this position until the beginning of 1949. In 1958 he relocated to Australia where he worked as an aviation advisor. On June 2, 1960 he retired and returned to Great Britain. On December 6, 2004 he passed away at the age of 92. During WWII Frank Carrey shot down 25 enemy aircraft individually and another three in cooperation. He also recorded four unconfirmed kills, three probables and eight aircraft damaged. He became one of the most successful Hurricane pilots.

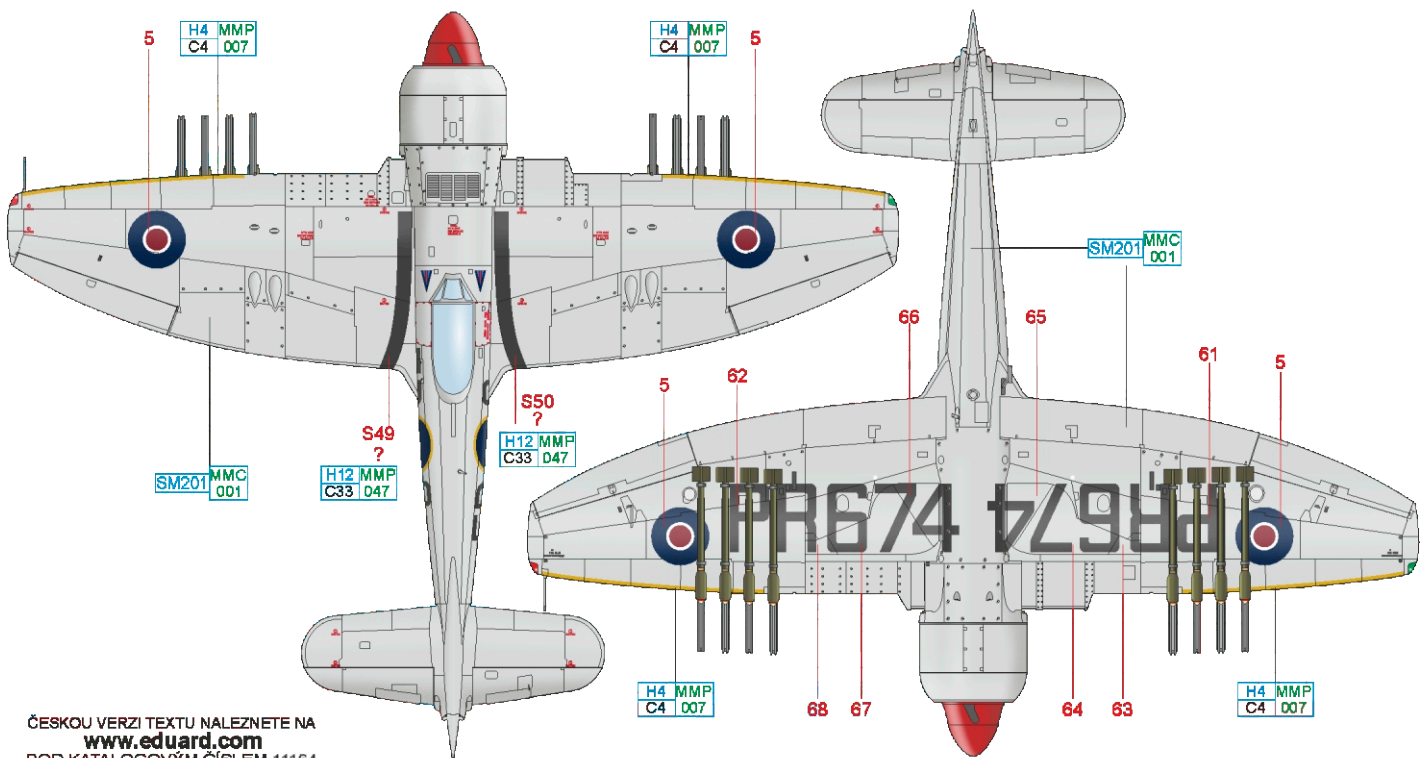
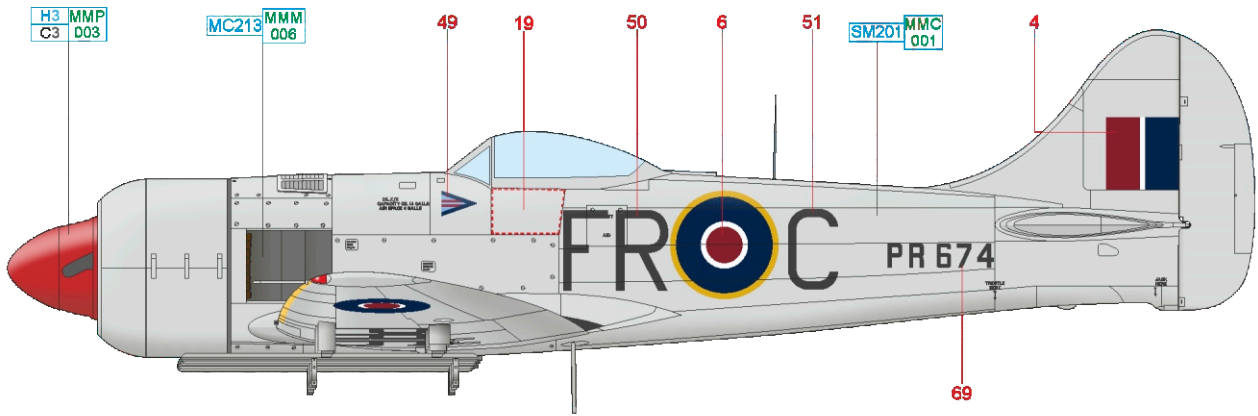

ČESKOU VERZI TEXTU NALEZNETE NA  
[www.eduard.com](http://www.eduard.com)  
 POD KATALOGOVÝM ČÍSLEM 11164

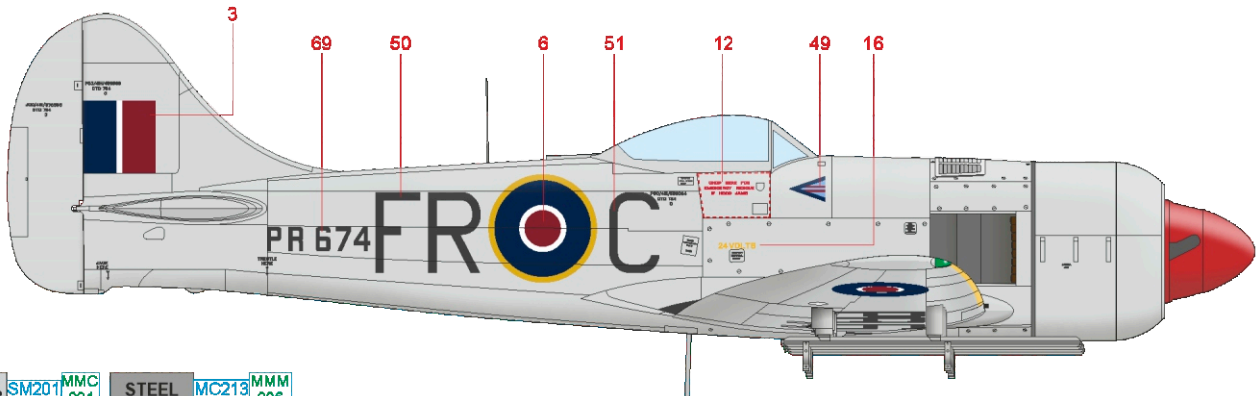

SUPER FINE SILVER	SM201 MMC 001	STEEL	MC213 MMM 006		
BLACK	H12 MMP C33 047	YELLOW	H4 MMP C4 007	RED	H3 MMP C3 003

# G A139 (ex PR809), No. 14 Squadron, Royal Pakistan Air Force, Pakistan, 1949

On November 1, 1948 in Peshavar the No. 14 Squadron of the Royal Pakistan Air Force was established. Only four days later the first encounter of RIAF and RPAF aircraft took place when two RIAF Tempests attacked the Pakistani Dakota. On January 15, 1949 the No. 14 Squadron was disbanded due to the fact that during December the unit had lost two Tempests and without replacement aircraft the situation became critical. The supplies of new Tempests commenced in March 1949 and the aircraft were immediately allocated to the combat units. They received the serials from A128 to A151 and were easily recognizable thanks to their desert camouflage scheme. The recognition stripes were not applied. As the material and personal situation improved on December 15, 1949 the No. 14 Squadron was again re-activated under the leadership of Julian Kazimierz Żuromski. On March 24, 1950 the unit has been relocated to Miranshah for its first combat deployment against Faqir of Ipi uprising.

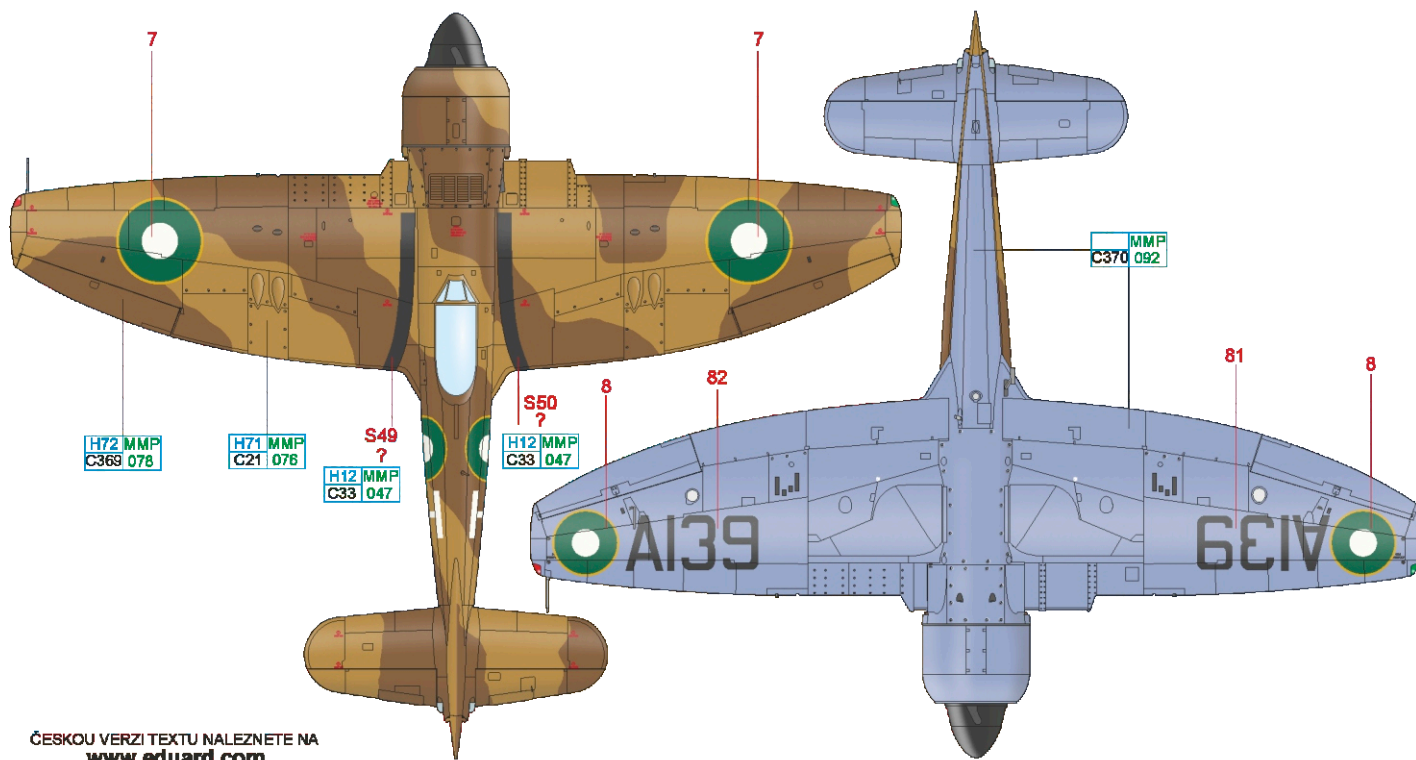
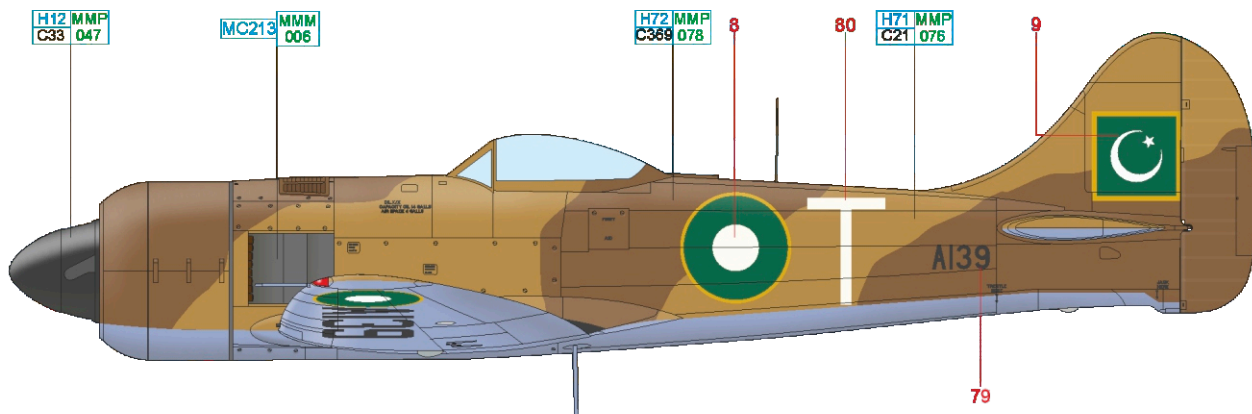

ČESKOU VERZI TEXTU NALEZNETE NA  
[www.eduard.com](http://www.eduard.com)  
 POD KATALOGOVÝM ČÍSLEM 11164

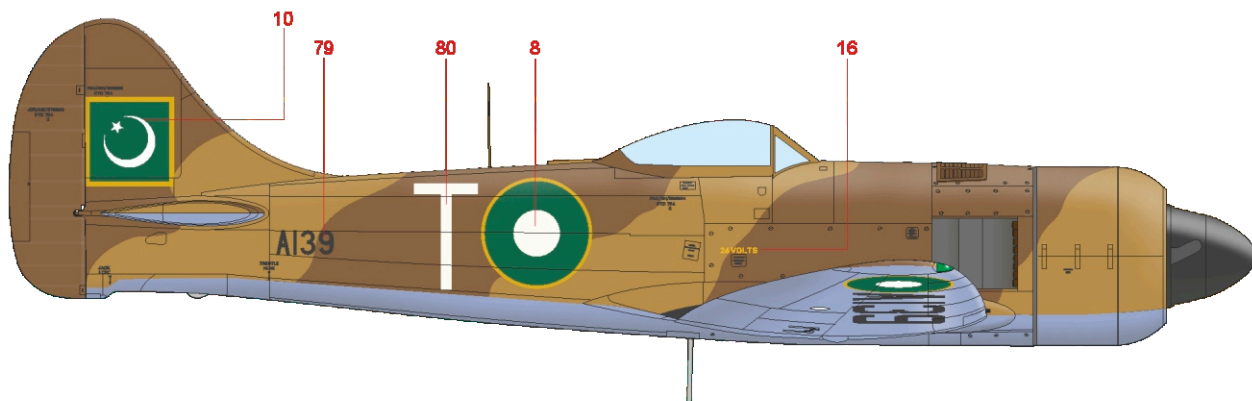

DARK EARTH H72 MMP C369 078 MIDDLE STONE H71 MMP C21 076 AZURE BLUE MMP C370 092 BLACK H12 MMP C33 047 STEEL MC213 MMM 006

# H HA547, No. 7 Squadron, Royal Indian Air Force, India, 1949

The first from 89 Tempests that underwent the overhaul and were delivered to RIAF, was HA547. Originally it was PR874 airframe which in February 1946 was delivered directly to the storage and after more than two years was sold from No. 20 MU (Maintenance Unit) back to Hawker in order to satisfy the aircraft deliveries for India and Pakistan. All Tempests were finished in Aluminum. Initially these aircraft carried the „Chakra“ style national insignia which were soon replaced by the new orange-white-green cockades. These were introduced in 1950.

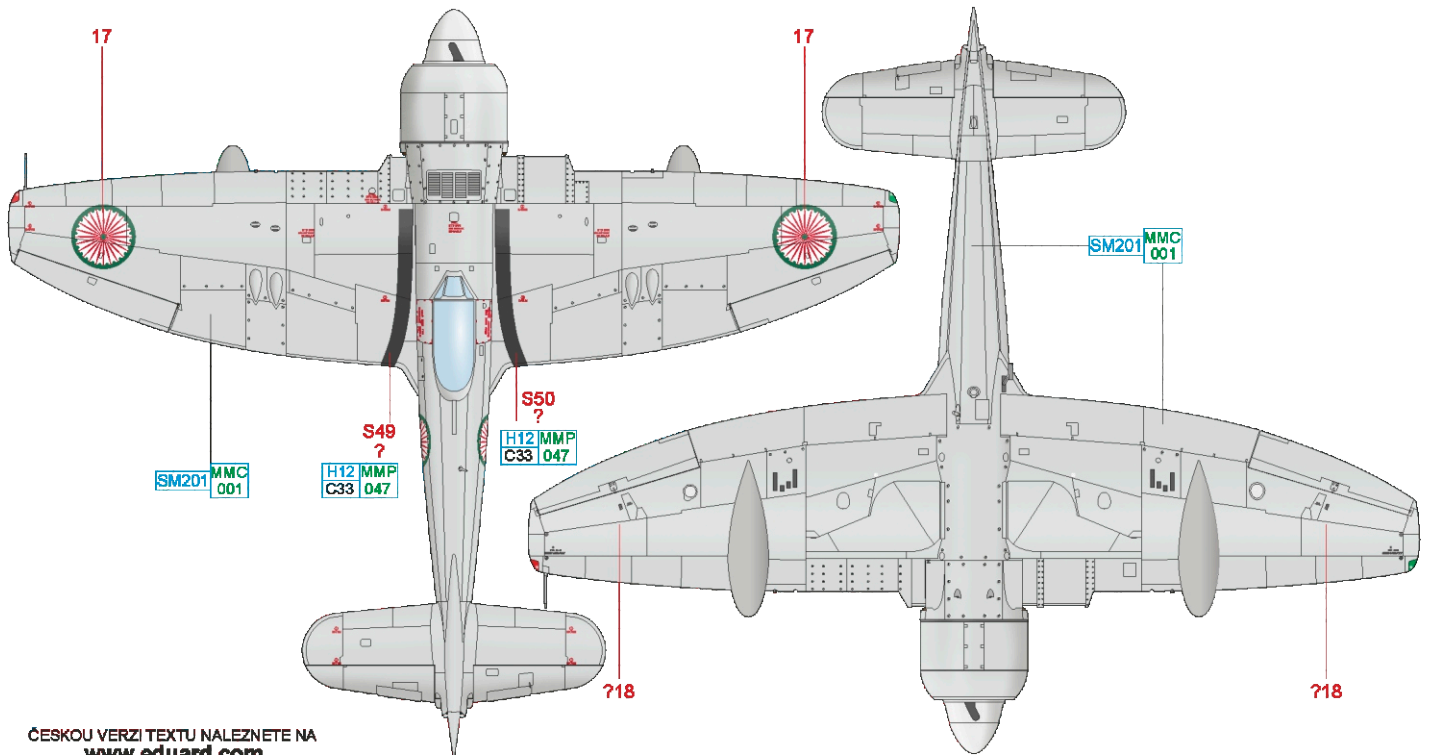
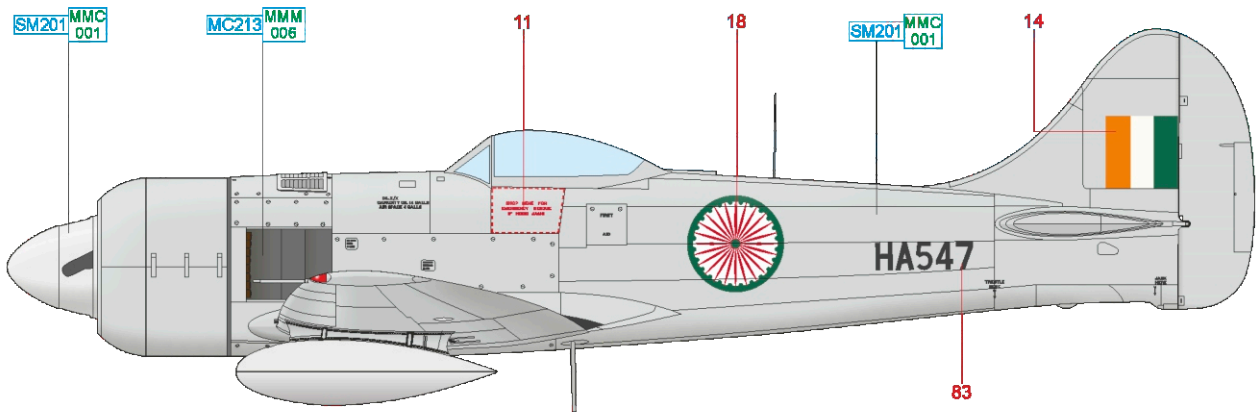

ČESKOU VERZI TEXTU NALEZNETE NA  
[www.eduard.com](http://www.eduard.com)  
 POD KATALOGOVÝM ČÍSLEM 11164

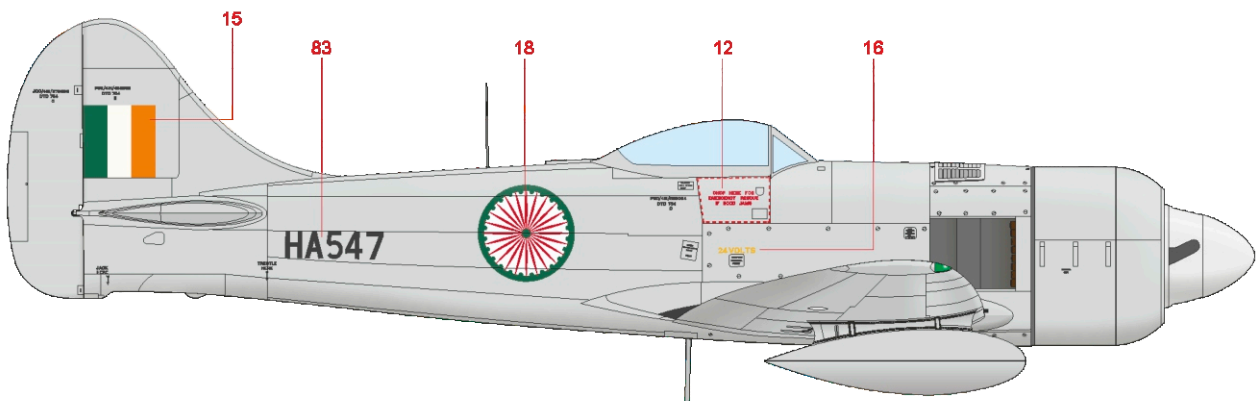

SUPER FINE SILVER SM201 MMC 001 STEEL MC213 MMM 006 BLACK H12 MMP C33 047



# HA426, No. 7 Squadron, Royal Indian Air Force, Jammu, India, December 1948

Even though HA426 from No. 7 Squadron still sports the original RAF Day Fighter Scheme it already carries the new orange-white-green RIAF cockades. There is a winged battle axe, No. 7 Squadron insignia, painted below the canopy. White wingtips as well as white propeller spinner and rear fuselage band were applied to RIAF Tempests to distinguish them from RPAF aircraft carrying the same camouflage.

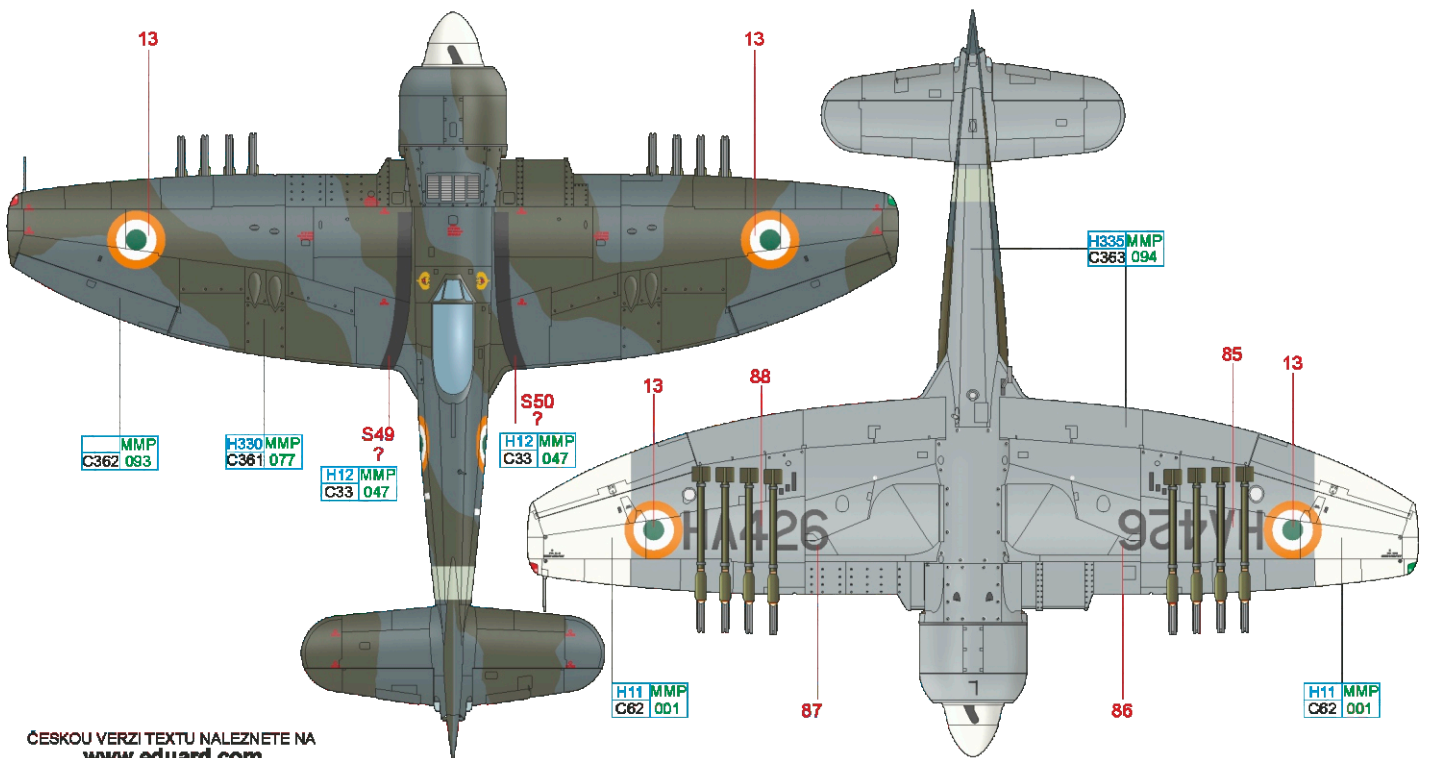
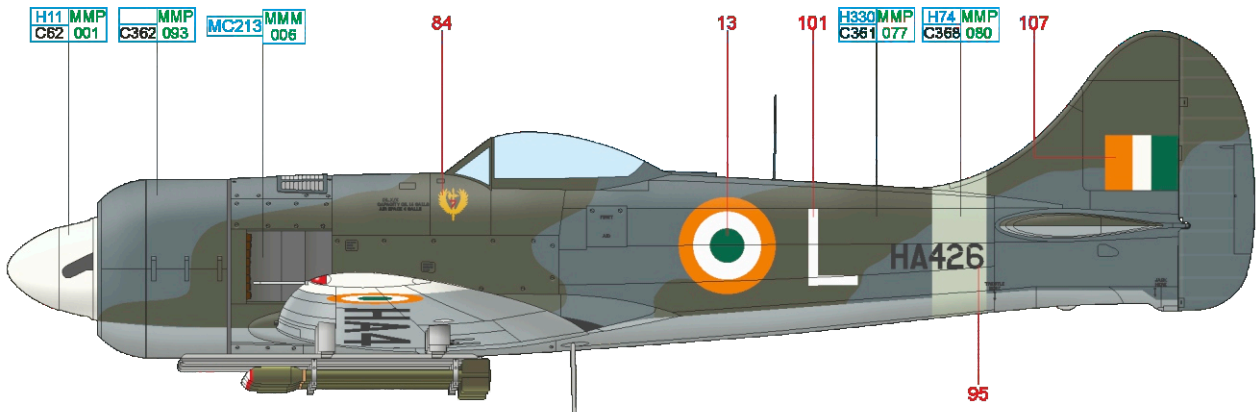

ČESKOU VERZI TEXTU NALEZNETE NA  
[www.eduard.com](http://www.eduard.com)  
POD KATALOGOVÝM ČÍSLEM 11164

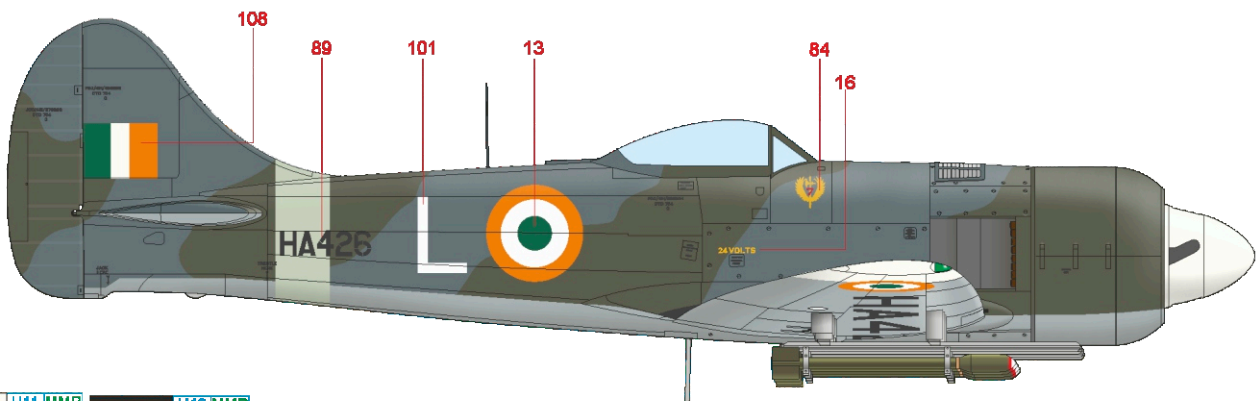

WHITE	H11 MMP C62 001	BLACK	H12 MMP C33 047
MEDIUM SEA GRAY	H335 MMP C363 094	DARK GREEN	H330 MMP C361 077
		OCEAN GRAY	MMP C362 093
		SKY	H74 MMP C368 080
		STEEL	MC213 MMM 006



# J PR836, F/Lt Michael P. O. Blake, No. 3 Squadron, Royal Indian Air Force, Kolar, India, 1946–1947

The first RIAF unit equipped with Tempests Mk. II was No. 3 Squadron which commenced the operations at Kolar airport in September 1946. In the same manner as with the other Indian squadrons the Tempests did not carry any fuselage codes except the individual letters. PR836 coded Q served with No. 3 squadron from October 1946 to May 14, 1947 when it was heavily damaged during the accident in Risalpur. After the landing the undercarriage broke off and S/Ldr M. L. Mishra was wounded. PR836 was often flown by F/Lt Michael Patrick Owen „Micky“ Blake who on October 27, 1946 had an honor to be the first Indian to fly a Tempest. His favorite PR836 with fuselage code Q was decorated with „Percy Prune“ comics character. Only part of the character, reaching the fuselage panel demarcation under the windshield is visible in the period photograph, however it is possible that it was painted all the way to wing joint.

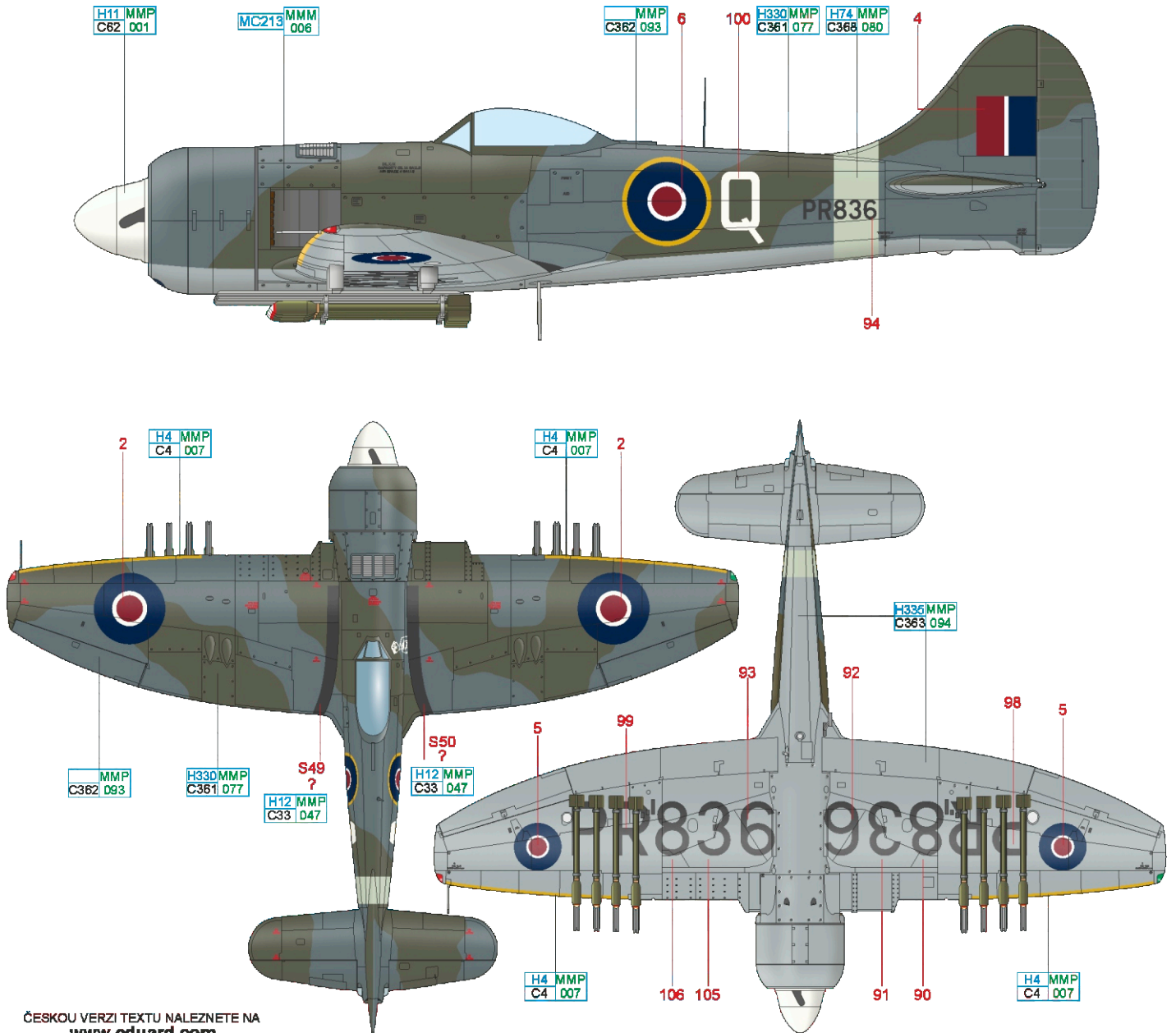

ČESKOU VERZI TEXTU NALEZNETE NA  
[www.eduard.com](http://www.eduard.com)  
 POD KATALOGOVÝM ČÍSLEM 11164

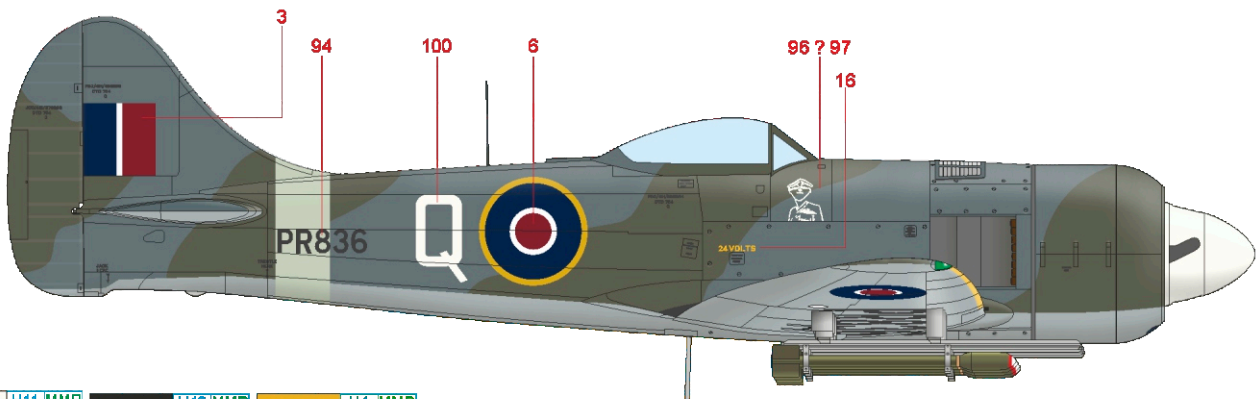

WHITE	H11 MMP C62 001	BLACK	H12 MMP C33 047	YELLOW	H4 MMP C4 007
MEDIUM SEA GRAY	H335 MMP C363 094	DARK GREEN	H330 MMP C361 077	OCEAN GRAY	MMP C362 093
		SKY	H74 MMP C368 080	STEEL	MC213 MMM 006

