

eduard

LIMITED



MIGHTY EIGHT

66th Fighter Wing

INSTRUCTION SHEET

1/48



11174-NAV1

LITTLE FRIENDS

66th Fighter Wing over Europe

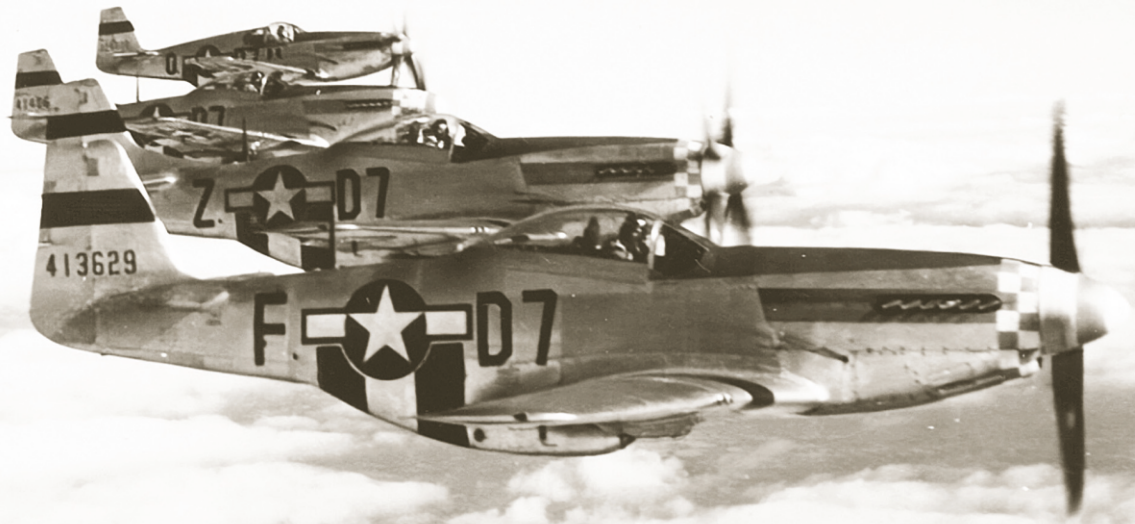

Photo: Museum of Air Battle over the Ore Mountains via Russ Abbey

by JAN ZDIARSKY

P-51 Mustang flight from 503rd FS, 339th FG

The strategic bombing offensive of the Western Allies, whose main goal was to weaken German industry and supply, stood on several pillars. The British Royal Air Force began to attack Germany with a gradually increasing intensity by the time of the Battle of Britain (apart from a few rather desperate attempts made sporadically from September 1939). Even before the American Air Force entered the European campaign, RAF Bomber Command moved to night operations and, with few exceptions, remained there until the end of the war. The daytime skies over Germany and occupied Europe were to belong primarily to the Americans, at least as far as long-range bombing operations are concerned.

Achieving the goals that the Americans had set for themselves in this regard consisted primarily in building a strong bomber force and support units, which were supposed to ensure supremacy in the skies over continental Europe through joint operations. Another pillar was war logistics, which was supposed to transport not only new aircraft and fresh crews to Europe, but also spare parts, equipment, hundreds of thousands of tons of fuel, bombs and other ammunition. It was such a complex and today a rather neglected component of the war effort that even a brief description of it would be well beyond the scope of this article. The third but no less important pillar was fighter support for the bombers. In Europe, the US Air Force's bombing operations rested on the shoulders of two separate air armies, the 8th Air Force, based in Great Britain, and the 15th Air Force, operating first from North Africa and then from southern Italy.

8th Air Force

The main strength wielded by the US Air Force in the European Theater of Operations (ETO) was undoubtedly the 8th AF, nicknamed the "Mighty Eighth". As the air component of the Air Force arm of the United States Army (Army Air Force), it was established in January 1942, as VIII. Bomber Command. Under the designation VIII. Bomber Command (which later became a permanent part of the 8th AF structure), it undertook its first operation in the ETO on July 4, 1942, with A-20 Havoc aircraft borrowed from the RAF. At the same time, airfields over eastern England began to see the arrival of regular units of VIII.

Bomber Command armed with B-17E bombers. The first distinct operation was a mission to Rouen-Sotteville, France, on August 17th, 1942. In February 1944, VIII. Bomber Command headquarters was integrated into the 8th Air Force and along with it, as part of the 'new' VIII. Bomber Command, existing bomber groups. Simultaneously, the VIII. Fighter Command was created, whose main task was to provide protection for the bombers.

The 8th AF reached its peak strength in the summer of 1944. By the end of August of that year, it consisted of three Bomb Divisions (later Air Division) with forty Bombardment Groups (or simply Bomb Groups) spread among fourteen Bombardment Wings and a separate Fighter Command, with three Fighter Wings with sixteen fighter Groups, each with three squadrons. In addition to these, the 8th AF included several reconnaissance and special operations, training and other support units. This was a force that was able to send 1,200 four-engine bombers and around 500 escort fighters over Germany in one day. Since the summer of 1944, the German Luftwaffe had rarely been able to effectively oppose such a force. In 1945, all but one of the Fighter Groups of the 8th AF were armed with P-51D aircraft, or the P-51K.

It is not without interest that the last combat operation of the 8th AF was a mission to Pilsen, Czechoslovakia on April 25th, 1945. A few days later, the bombers of the 8th AF participated in Operation Mana to supply food to the population of the Netherlands, which was on the brink of starvation, after German troops cut off the food supply.

15th Air Force

The Second US strategic air force in Europe was the 15th Air Force, formed in November 1943 in North Africa from parts of the tactical 12th and 9th AFs. It was only in December 1943 that the newly formed units of the 15th AF received four-engine bombers and a successful series of bombing missions could thus be undertaken, although the first raid by heavy bombers of the 15th AF on the west coast of Italy on January 22, 1944 had more of a tactical support flavor to it. Major missions were to come mainly after the transfer of the 15th AF to Italy (January - March 1944), when their bombers could reach deeper into occupied Europe and into Germany itself. At the end of the war, the 15th AF had four B-24 Liberator Bomber Wings and one B-17 Flying Fortress Wing. Fighter support was provided by two Fighter Wings with P-38, P-47 and, later, P-51 aircraft. The last mission of the 15th AF came on May 1st, 1945, the target being Salzburg in Austria.

66th Fighter Wing

As noted above, in August 1944, the 8th AF had sixteen Fighter Groups. These were incorporated into three Fighter Wings, namely the 65th FW, 66th FW and 67th FW. The affiliation of specific fighter groups to a given Wing was more or less stable. At the same time, these Wings usually provided escort for bombers of specific divisions from the 8th AF (65th FW for Liberators from the 2nd BD, 66th FW escorted B-17s from the 3rd BD and 67th FW B-17s from the 1st BD). The 66th FW was formed around five Fighter Groups as follows.

55th FG

Nuthampstead September 1943 - April 1944

Wormingford April 1944 - May 1945

For the first six months of its operational activity, the unit was based at Nuthampstead Base north of London, which it later had to leave to make way for the newly arrived 398th BG. Until the summer of 1944, the unit flew the P-38 Lightning, which was replaced by the P-51D Mustang. A number of pilots of this unit thus flew in combat on both types. The identification marking applied up to the P-51 was initially a black stripe on the front of the engine cowl and a black spinner. This was soon replaced by a yellow-green checkerboard pattern and stripes of the same colors on the spinner. A distinguishing feature of the unit was also the color differences in the fuselages of the Mustangs of the individual squadrons, a practice that was abandoned especially by the later months of the war. While the 38th FS had horizontal and vertical tail surfaces painted olive green, the 338th FS flew mostly without any coloring of the tail surfaces. The most impressive livery of this unit were the Mustangs of the 343rd FS, whose anti-glare panels in front of the cockpit arced back to encompass the rest of the

fuselage, with the entire fuselage behind the cockpit being sprayed the same olive green. These were not remnants of the OD/NG (olive drab / neutral gray) coloring, because the 55th FG converted over to Mustangs later, meaning that their machines would have been delivered in natural metal and aluminum spray. The arc of green on the fuselages of 343rd FS Mustangs was often edged with dark red or yellow. On occasion, this coloring also appeared on the aircraft of the 338th FS. On the other hand, at the end of the war, the 343rd FS often had its machines only in bare metal coloring, only with a checkerboard pattern on the nose. Also, the 38th FS in 1945 was abandoning the full coloring of the tail surfaces. Instead, identifier colors were applied to the rudders - 38th FS red, 338th FS light green and 343rd FS yellow.

339th FG

Fowlmere April 1944 - May 1945

The 339th FG was among the newer units of the 8thAF, and therefore arrived in England already wielding P-51 aircraft. Fowlmere, near Duxford, became its base throughout its operational deployment in Europe. The P-51Bs and Cs used at first were replaced by more modern P-51D and K versions during the summer of 1944, but some older B and C fighters remained in service for quite a long time, until the fall of 1944. The identification marking of the unit was a red and white checkerboard on the front of the engine cowl and included the spinner. Later, unit specific squadron colors were applied to the rudder - the 503rd FS received a red rudder, the 504th FS received a green one, while the 505th FS received yellow.

357th FG

Raydon November 1943 - January 1944

Leiston January 1944 - May 1948

The "Yoxford Boys", as the 357th FG was nicknamed, moved to England in November 1943. The unit spent a short time at Raydon Base before being moved to Leiston. The 357th FG marking is one of the most impressive to appear in the 8th AF. Many of her early P-51Bs and Cs were still in OD/NG livery, and that combined with the yellow-red checkerboard and, for a period of time, invasion stripes really suited the Mustangs of this unit. However, even natural metal airplanes (and sprayed aluminum) appear unusually colorful in conjunction with that unit's markings. Although a wide variety of markings cannot be denied to other units within the 66th FW, the 357th FG itself was certainly the most varied. Later, this unit also added identification markings of individual squadrons by spraying its rudders - the 363rd FS used red, the 364th FS yellow, and the 362nd FS rudders often remained unpainted, unless the entire fuselage was sprayed olive. With 609 credited aerial victories and 109 aircraft destroyed on the ground, the 357th FG

Even tight formations failed to protect USAAF bombers effectively from attacks by Luftwaffe fighters. Only the deployment of the P-51 turned the situation in the Allies' favor.



photo: 487th BG

Lt. Jones' Mustang from the 38th FS, 55th FG shortly after returning from a combat operation.



Photo: Museum of Air Battle over the Ore Mountains via David Jewell

was the most successful unit with the P-51 and the second most successful unit within the USAAF. It is therefore not surprising that more than half of the fighter aces who earned their glory with the 66th FW came from the 357th FG.

353rd FG

Goxhill June 1943 – August 1943

Metfield August 1943 – April 1944

Raydon April 1944 – May 1945

For more than a year, this unit operated the P-47 and re-armed with the P-51D in October, 1944. The marking of the group was a black and yellow checkerboard on the nose. Sometimes, it consisted of only three rows, sometimes it was applied to more than half of the nose of the aircraft, even to the extent that it obliterated the anti-glare panel in front of the cockpit. For the P-47, the checkerboards were originally skewed diagonally, later they were sprayed parallel to the horizontal axis of the aircraft. These were also applied to the P-51. The color identifiers of individual squadrons also later appeared for this unit: the 350th FS yellow, 351st FS usually without, the 352nd FS black. The coloring of 353rd FG Mustang rudders was not consistent, and the mentioned colors also appeared on aircraft of other squadrons and therefore cannot be considered definitive identifiers of squadrons within the FG.

78th FG

Goxhill December 1942 – April 1943

Duxford April 1943 – May 1945

One of the oldest fighter units of the 8th AF saw its baptism of fire in the service of the 12th AF in Africa, flying P-38 Lightnings at the time. It returned to England much weakened and in April, 1943 was re-equipped with P-47s. It was on this type

that the unit would gain its fame. It did not convert on to the P-51 until December, 1944. The unit's marking was a distinctive black-and-white checkerboard over almost the entire nose of their Mustangs (and previously over the P-47 engine cowls). The individual squadrons were later distinguished by the color applied to the rudder: the 82nd FS used red, the 83rd FS white, and the 84th FS black.

3rd Scouting Force

Wormingford February 1945 – May 1945

A special unit, built and supported by the 55th FG, was based with this fighter group at Wormingford. Although it was independent, it was functionally related to the 66th FW and was intended to support the 3rd BD. Administratively, however, it fell under the 493rd BG. Its task was to cooperate closely with the bomber associations in weather reconnaissance en route to the target and especially over the target. The Mustang pilots of the 3rd SF were initially dedicated pilots of the 55th FG, but later, their role was taken over mainly by volunteers – experienced former heavy bomber pilots who completed their operational tour. They knew best what information was needed, and when by their colleagues flying the route behind them. In addition to Mustangs, the unit also flew P-47s and B-17Fs. The color identifiers of their P-51s consisted of red trim on the leading edge of the fillet. The different checkerboards on the cowls were consistent with the unit that the aircraft being flown originated with, predominantly being the 55th FG.

For a very short time, the 66th FW also had other groups, most of the time assigned to other Wings – the 4th FG (1945), 56th FG (1945), 359th FG (1943), 361st FG (1943–44, 1945) and the 479th FG (1945), possibly to the 9th AF (358th FG). However, their temporary involvement with the 66th FW was marginal and we only mention them because they are mistakenly listed as a permanent part of the 66th FW by some sources. Despite this, one of them – the 361st FG – is worth

A photo from early period of 8th AF bomber escorts shows a P-38 Lightning of 338th FS, 55th FG.



Photo: Museum of Air Battle over the Ore Mountains via David Jewell

bringing up. This unit was a bit of a jack-of-all-trades, plugging holes where needed. It gradually went through service with all three FWs and at the turn of 1944/45 it was even temporarily tasked with ground support with the 9th Air Force.

The plans for the reorganization of the 8th AF from March 1944, included a version of things that would see the 352nd FG falling under the 66th FW, but in the end it remained part of the 67th FW as did the 50th FG. However, after coming to the ETO, it found itself subordinate to the 9th AF. At the same time, the 353rd FG was to be integrated into the 67th FW. The same document also assigned individual FWs to respective Bombing Divisions, but later reality proved to be different. The 66th FW was to support the 2nd BD, the 67th FW the 1st BD, and the 65th FW was to accompany the 3rd BD on missions.

Big Brothers and Little Friends

From the very first operations of American bombers in Europe in 1942, it was clear that the current group defense tactics of the USAAF bombers was inadequate to deal with the capabilities of the German Luftwaffe. Bomber formations, at the mercy of German single and twin-engine fighter packs, suffered heavy losses. So much so that stopping this method of operations was considered. This can be seen in the raids of the 8th Air Force from the summer of 1942 and especially during the spring to autumn of 1943. It was obvious that without high-quality fighter protection these operations were doomed to failure. The generally known problem was the fact that neither the RAF nor the USAAF had the kind of fighter aircraft that could accompany their Big Brothers over Germany. In August, 1943, the P-47 Thunderbolt aircraft, equipped with drop tanks, were able to accompany the bombers to a distance of approximately 375nm, which roughly corresponded to the area of Frankfurt am Main, Hanover, or Kassel. This, of course, provided that they did not get into a fight with German fighters. Any significant change in the flight regime, let alone the necessity of premature jettisoning of the extra tanks, of course significantly shortened their range. The P-38 had a greater range and in December 1943 they were able to scrape the area of "Big B", Berlin itself (approx. 520 nm). However, their combat capabilities at that time were already significantly behind the newer versions of the Luftwaffe's main fighter types, the Bf 109G-6 and Fw 190A-5 and their following variants. Only the P-51B and C, which appeared in Europe at the turn of 1943 / 1944, were able to escort bombers deeper over the Reich itself and the center of Europe. Significantly better protection of the bombers was provided by the P-51D, which entered service during the summer of 1944. These were not only able to escort the bombers to the vast majority of their targets on the continent, but in several cases of special operations of the Frantic type, they protected their Big Brothers taking off from their home bases in Great Britain up to the region of Poltava and Mirgorod in Ukraine (approximately 1,300 nm).



photo: public domain

P-51D 44-64051 from the 362nd FS, 357th FG at Leiston

As the Luftwaffe's ability to respond to American raids weakened, the role of escort fighters shifted partly to ground attack. American aviators destroyed locomotives, substations, German planes on the ground, river boats and other means of transport. In essence, everything that could even remotely appear to be a target of military importance had to be on the lookout for the hunters' thirst. Protecting the bombers from Luftwaffe aircraft remained a priority task, as long as there was something to protect them from. However, the impression that the German air force was already completely defeated could be very dangerous. This was especially true in the closing months of the war, when Me 262 jets began to appear more and more regularly among the intercepting fighters, which in classic combat were a difficult opponent even for Mustang pilots. Unfortunately for the Germans, realizations regarding the conduct of the war came too late. "Jets" became the prestigious hunting trophy of many USAAF fighters. It will probably remain an eternal topic of historical debate, which weapon, vehicle or aircraft primarily provided the Allies with the opportunity to end the war in Europe by the spring of 1945 and which element thus ensured the air supremacy necessary for victory. Among the main favorites of the debates will understandably be the planes participating in the strategic bombing of German war industry and transport. And even among proponents of this theory, there will be differences of opinion as to whether these were the four-engined B-17s and B-24s, or their "Little Friends". Even if the final answer were to be the four-engined heavies, it is quite certain that without their "little brothers" and among them the P-51D, they would never have been able to do their job.

photo: public domain



P-51D 44-15469 "Bucephalus" from 78th FG. On this aircraft Lt. William E. Hydorn achieved an aerial victory over a Me 262 on February 2, 1945.

ATTENTION



UPOZORNĚNÍ



ACHTUNG



ATTENTION



注意



Carefully read instruction sheet before assembling. When you use glue or paint, do not use near open flame and use in well ventilated room. Keep out of reach of small children. Children must not be allowed to suck any part, or pull vinyl bag over the head.



Před započítím stavby si pečlivě prostudujte stavební návod. Při používání barev a lepidel pracujte v dobře větrané místnosti. Lepidla ani barvy nepoužívejte v blízkosti otevřeného ohně. Model není určen malým dětem, mohlo by dojít k požití drobných dílů.

INSTRUCTION SIGNS * INSTR. SYMBOLS * INSTRUKTION SINNBILDEN * SYMBOLES * 記号の説明

OPTIONAL
VOLBABEND
OHNOUTSAND
BROUSITOPEN HOLE
VYVRTAT OTVORSYMETRICAL ASSEMBLY
SYMETRICKÁ MONTÁŽREMOVE
ODŘÍZNOUTREVERSE SIDE
OTOČITAPPLY EDUARD MASK
AND PAINT
POUŽIT EDUARD MASK
NABARVITPLEASE CHECK THE LATEST VERSION OF THE INSTRUCTIONS ON www.eduard.com

PARTS



DÍLY



TEILE



PIÈCES



部品

PLASTIC PARTS

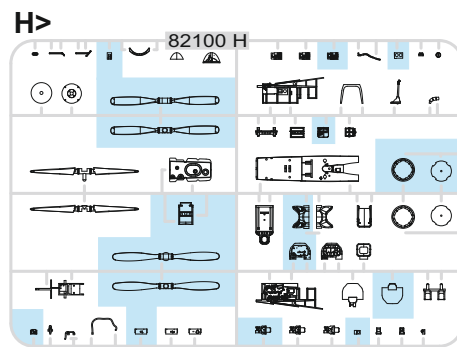
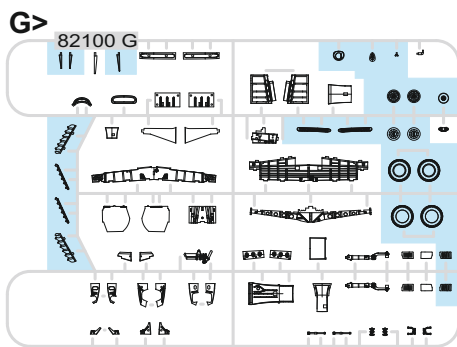
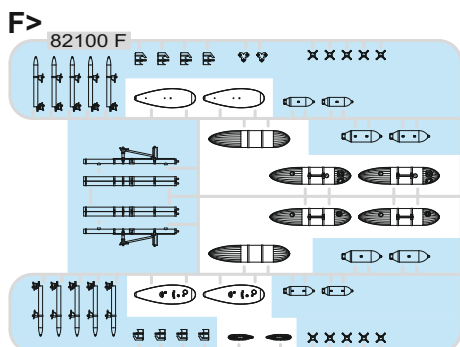
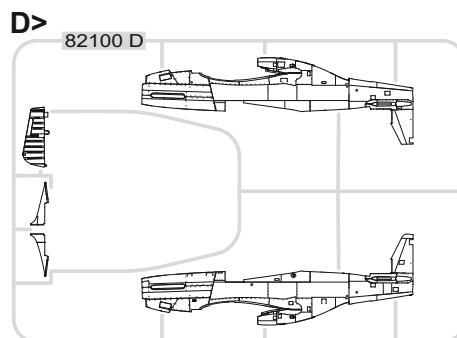
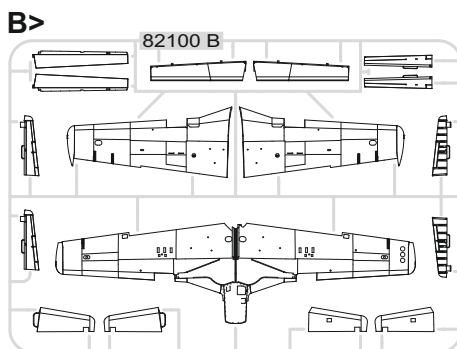
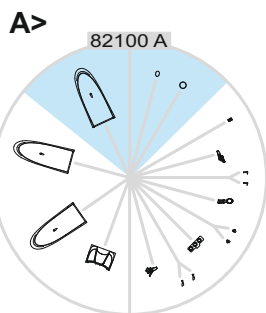

RP - RESIN PARTS

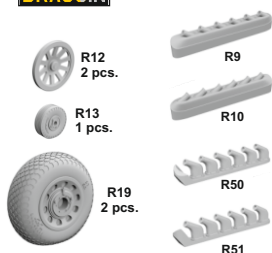

PE - PHOTO ETCHED DETAIL PARTS

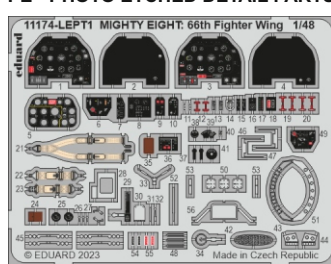

eduard MASK



Parts not for use. -Teile werden nicht verwendet. -Pièces à ne pas utiliser. -Tyto díly nepoužívejte při stavbě. - 使用しない部品

COLOURS



BARVY



FARBEN



PEINTURE



色

GSI Creos (GUNZE)		
AQUEOUS	Mr.COLOR	
H1	C1	WHITE
H6	C6	GREEN
H8	C8	SILVER
H11	C62	FLAT WHITE
H12	C33	FLAT BLACK
H27	C44	TAN
H37	C43	WOOD BROWN
H47	C41	RED BROWN
H52	C12	OLIVE DRAB
H53	C13	NEUTRAL GRAY
H58	C351	INTERIOR GREEN
H77	C137	TIRE BLACK
H90	C47	CLEAR RED

GSI Creos (GUNZE)		
AQUEOUS	Mr.COLOR	
H91	C48	CLEAR YELLOW
H94	C138	CLEAR GREEN
H327	C327	RED
H329	C329	YELLOW
H330	C361	DARK GREEN
H335	C363	MEDIUM SEAGRAY
	C352	YELLOW CHROMATE
Mr.METAL COLOR		
	MC214	DARK IRON
Mr.COLOR SUPER METALLIC		
	SM201	SUPER FINE SILVER
	SM203	SUPER IRON

A 1 = 90% + 10%
 H58 C351 INTERIOR GREEN H12 C33 FLAT BLACK

PE56 - MARKINGS E, G ONLY

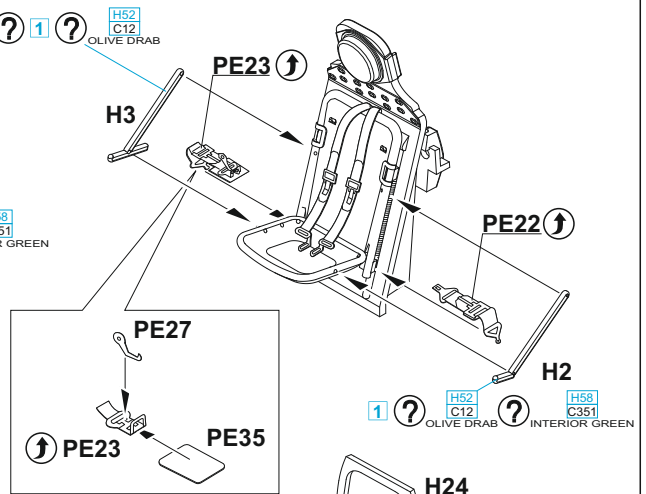
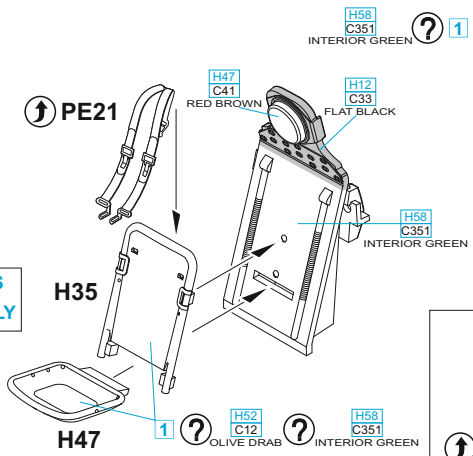
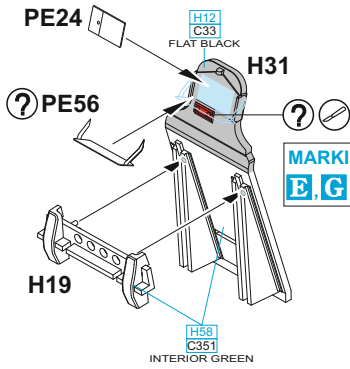

MARKINGS E, G ONLY

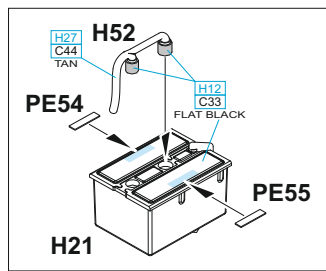

step 4

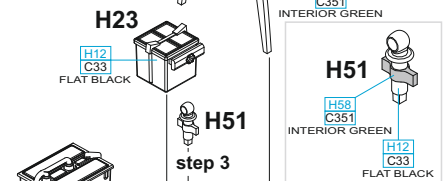

step 3

step 2

step 1

SIDE VIEW

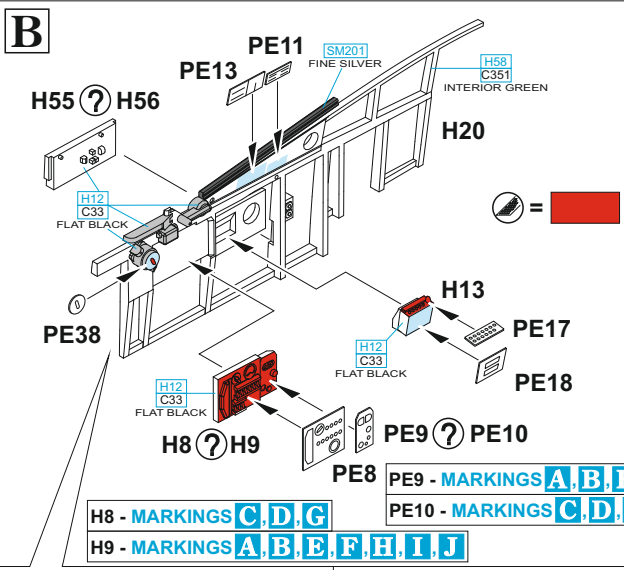
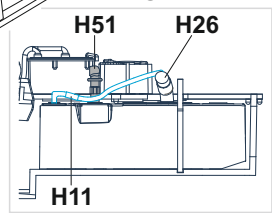

MARKING D ONLY

MARKING D ONLY

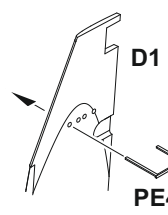

4x ø - 0,2 mm

H8 - MARKINGS C,D,G
 H9 - MARKINGS A,B,E,F,H,I,J

PE9 - MARKINGS A,B,E,F,H,I,J
 PE10 - MARKINGS C,D,G

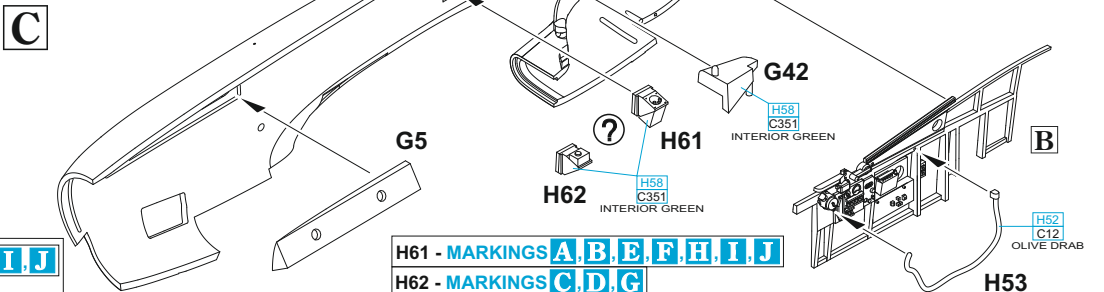
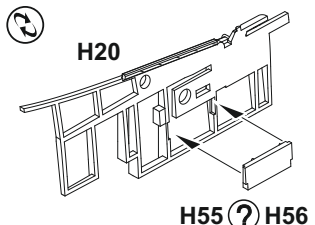

H61 - MARKINGS A,B,E,F,H,I,J
 H62 - MARKINGS C,D,G

H55 - MARKINGS A,B,E,F,H,I,J
 H56 - MARKINGS C,D,G

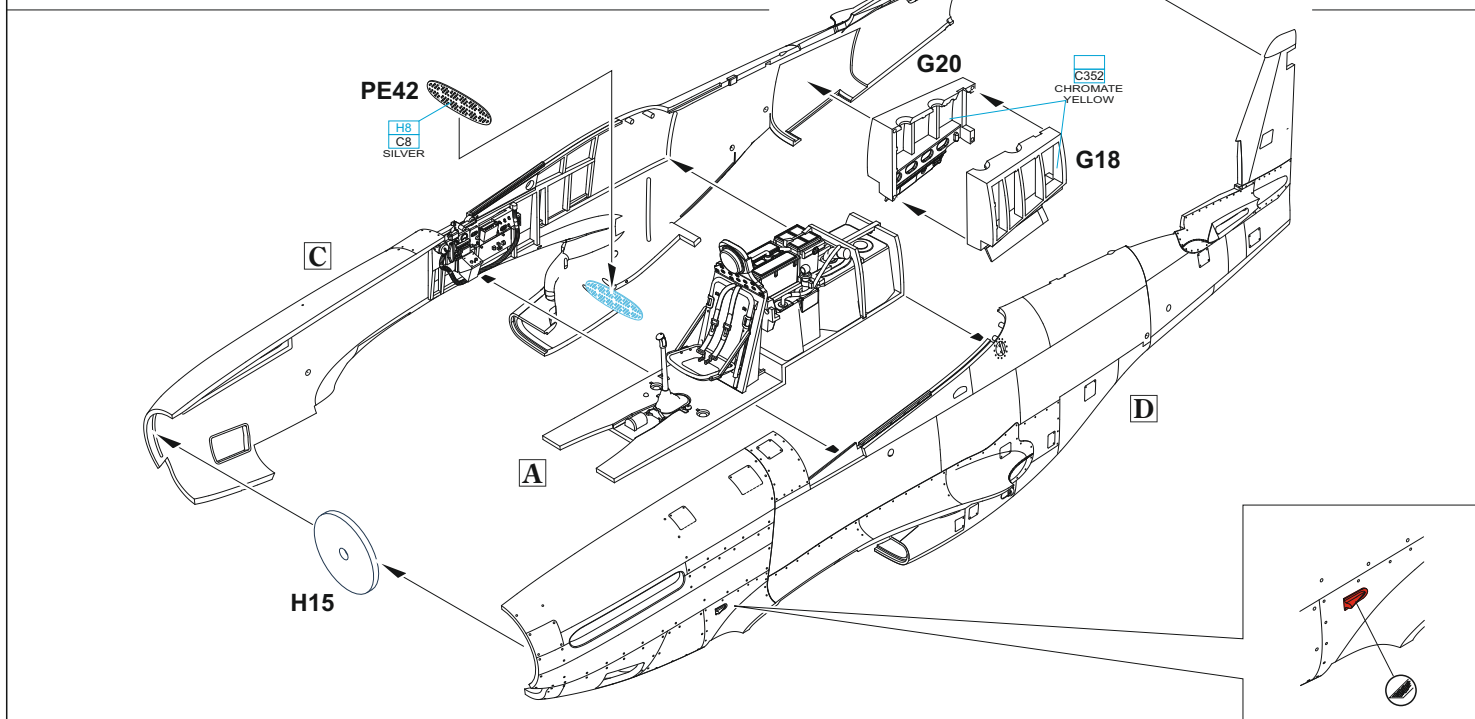
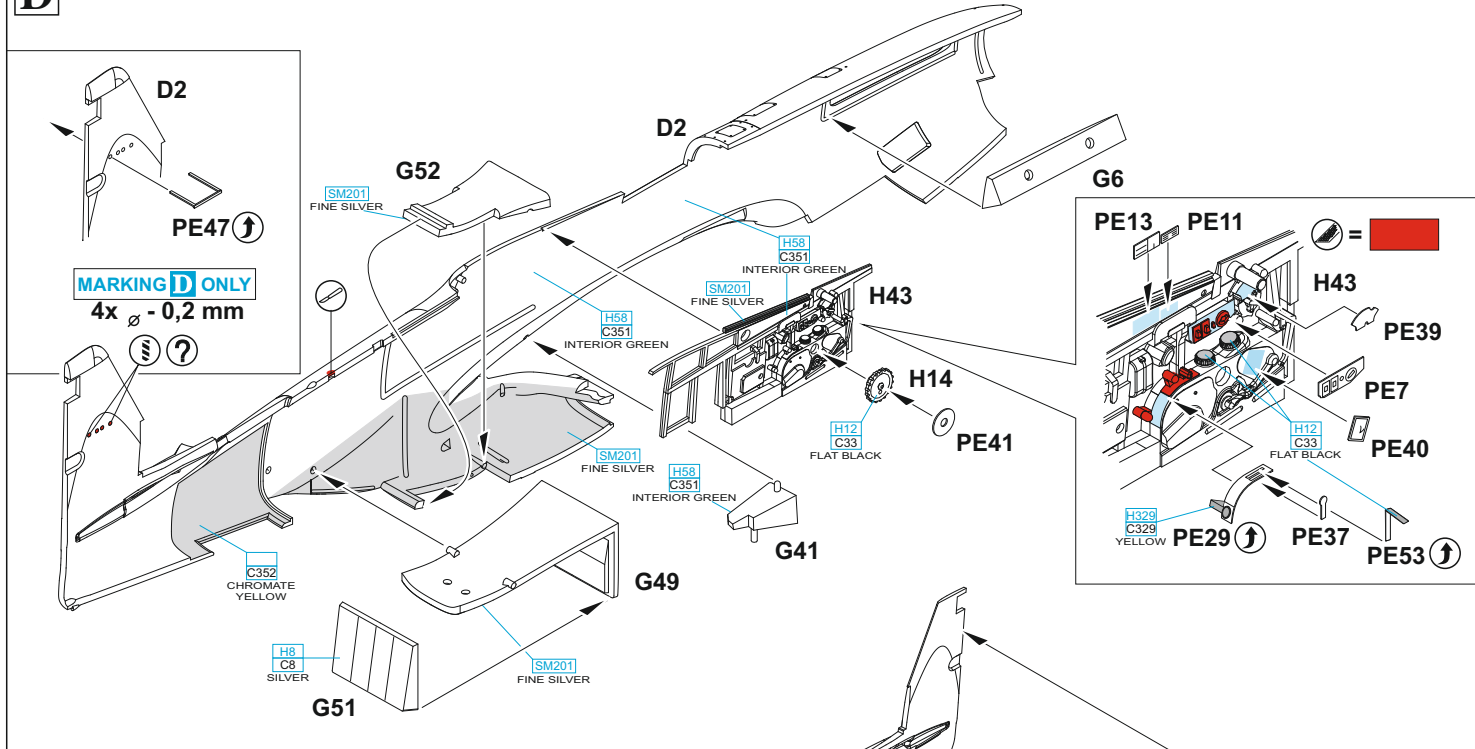
D

2 = SM201 - MARKINGS **E; F; H; I**
FINE SILVER
C352 - MARKINGS **A; B; C; D; G; J**
CHROMATE YELLOW

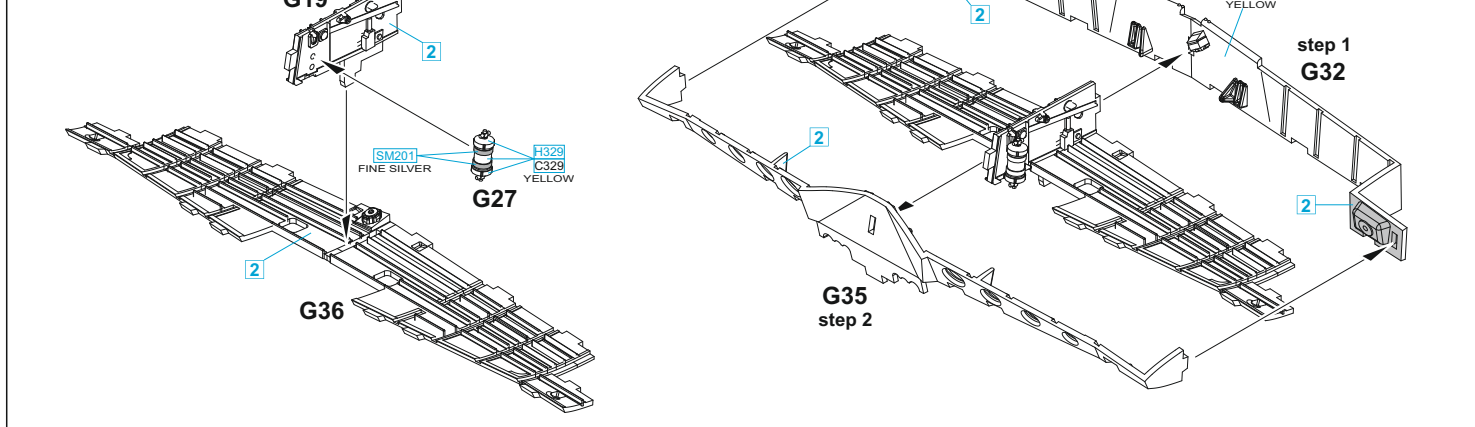
E

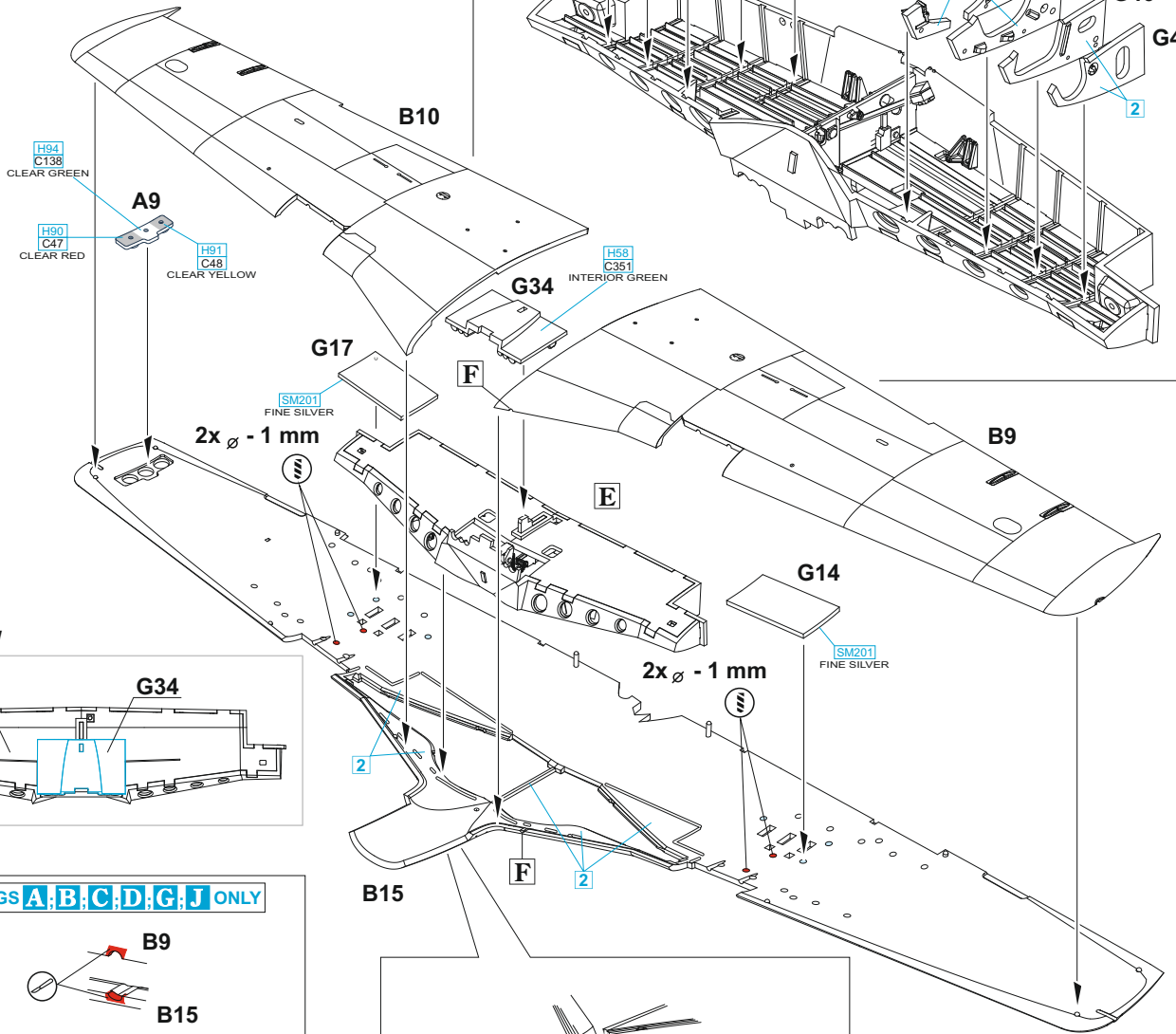
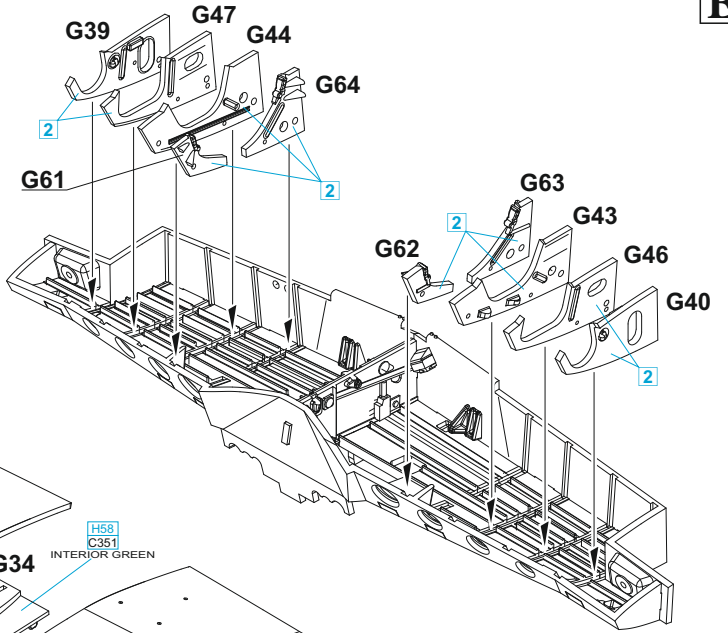
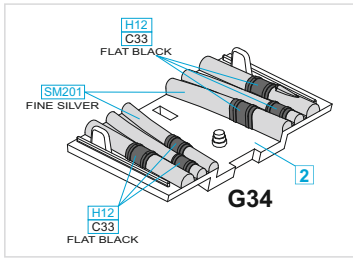

UPPER VIEW

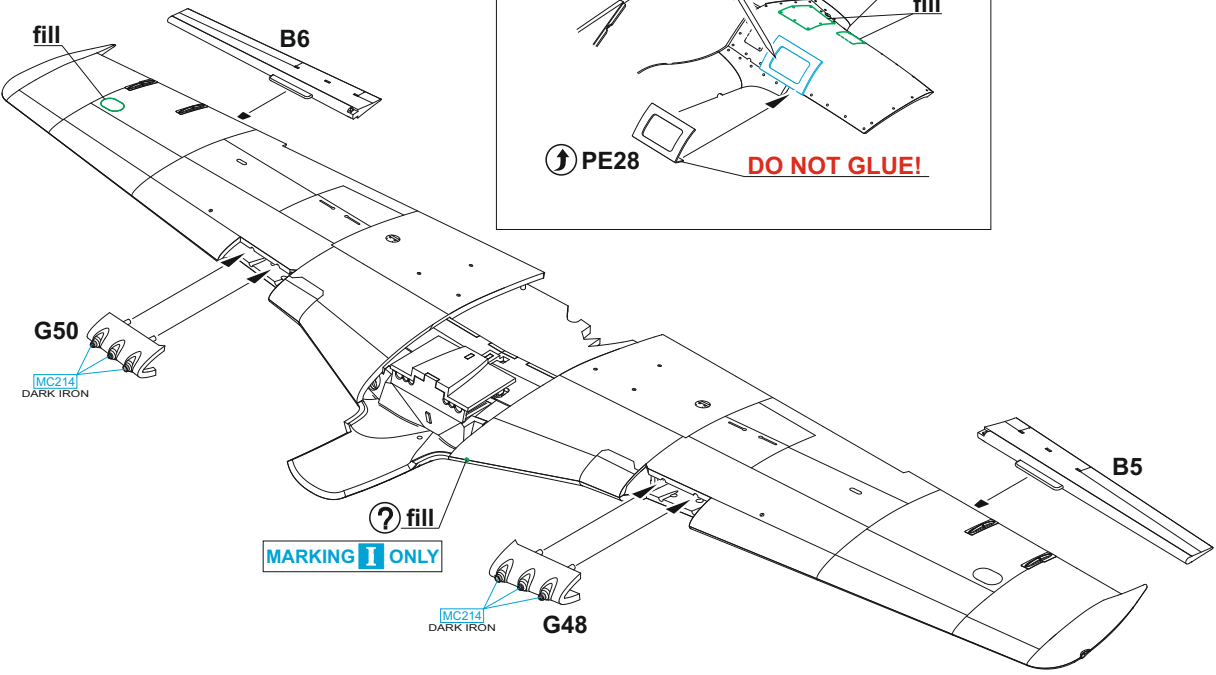
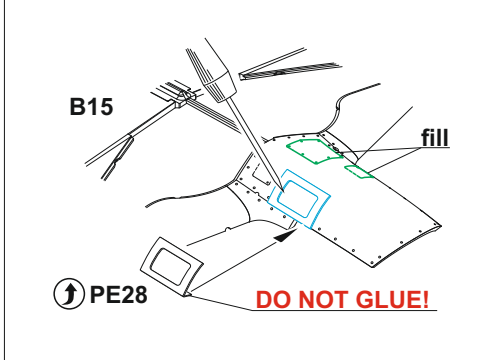
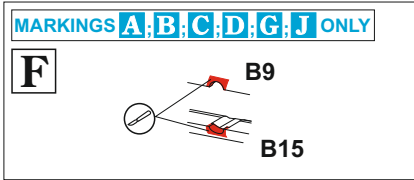
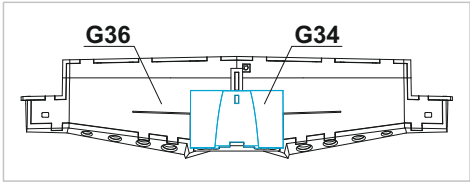

MARKING **I** ONLY

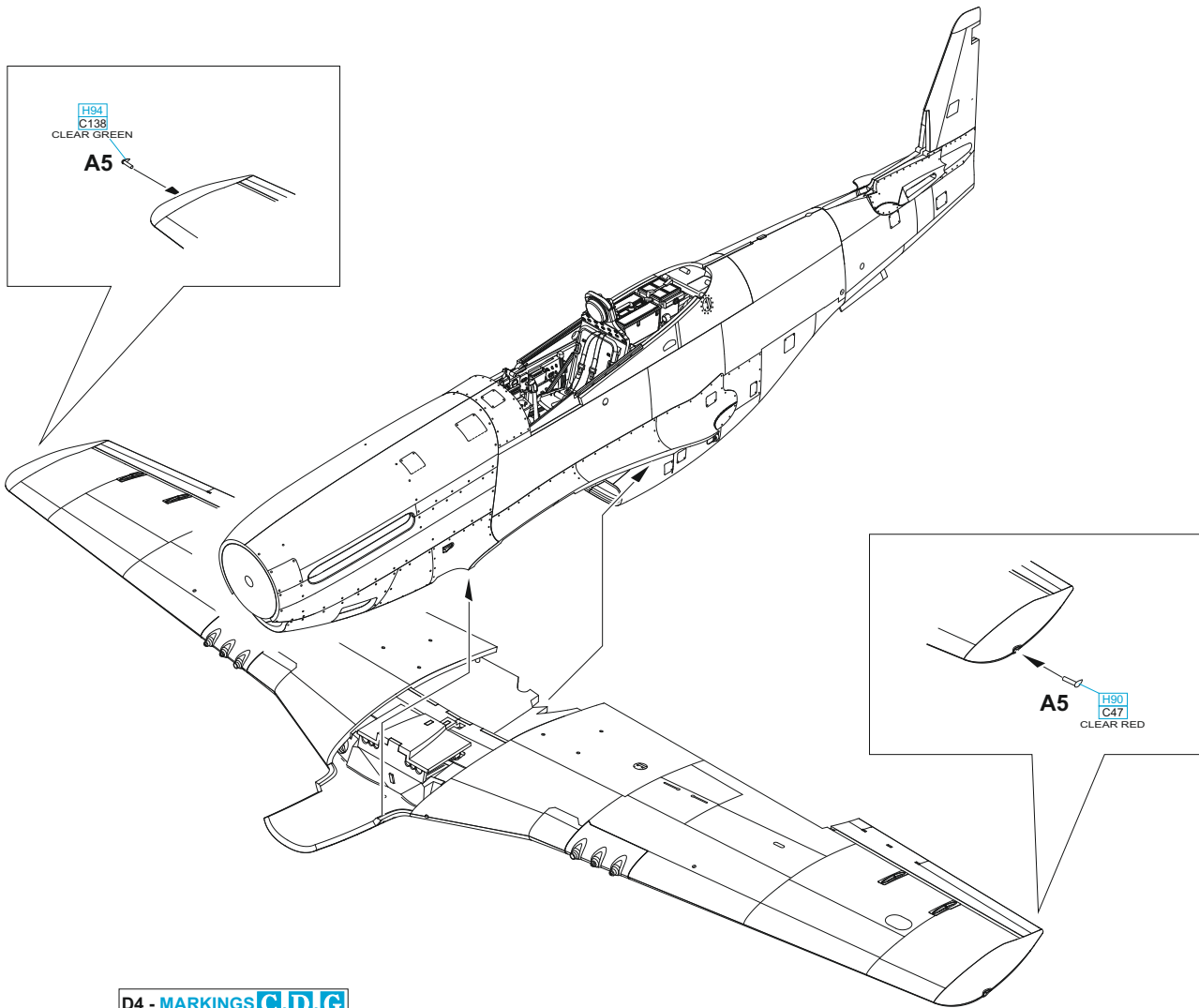

D4 - MARKINGS **C, D, G**
 D5 - MARKINGS **A, B, E, F, H, I, J**

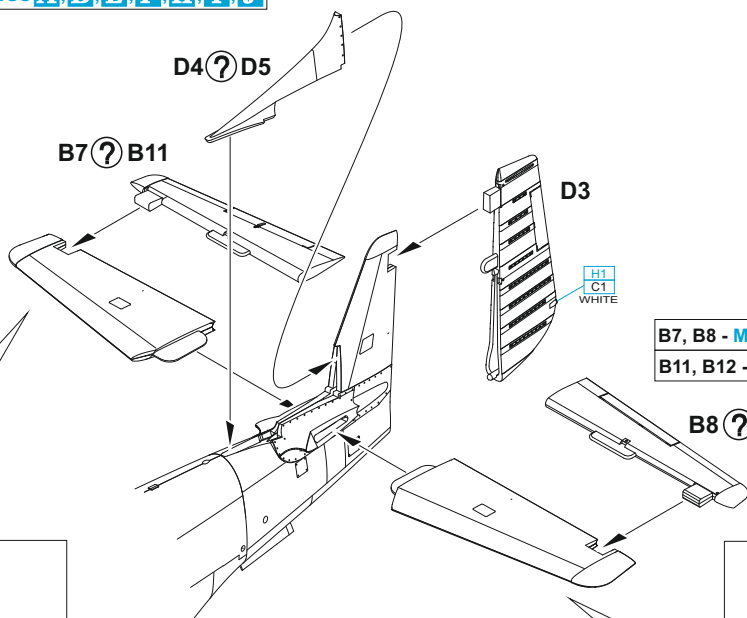

B7, B8 - MARKINGS **A, C, D, E, G**
 B11, B12 - MARKINGS **B, F, H, I, J**

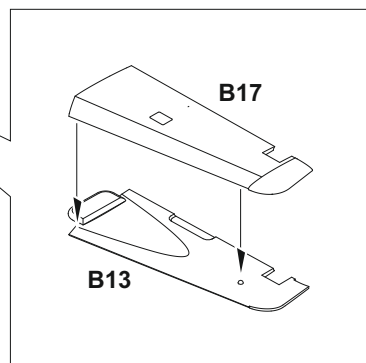
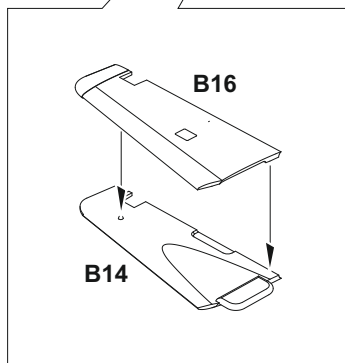

PE1, PE2, PE6 - MARKINGS **A, B, E, F, H, I, J**

PE3, PE4, PE49 - MARKINGS **C, D, G**

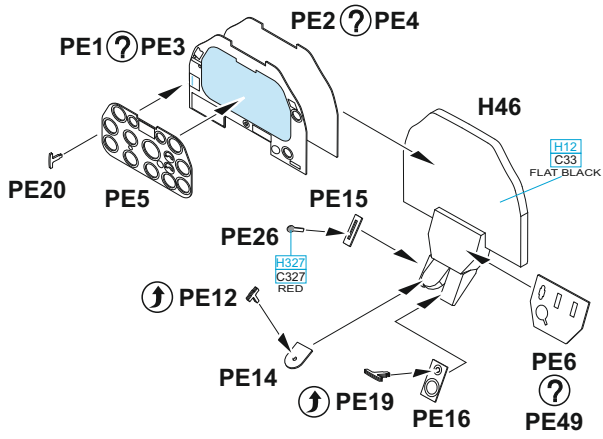

A8 starboard → A7 port side

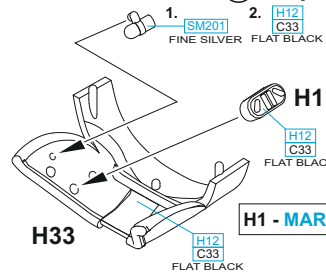

H1 - MARKINGS **A, C, D, E, G** ONLY

A3, A4 - MARKINGS **A, C, D, E, G**

A11 - MARKINGS **B, F, H, I, J**

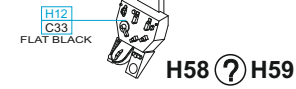
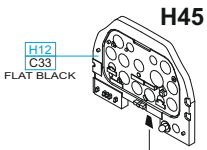
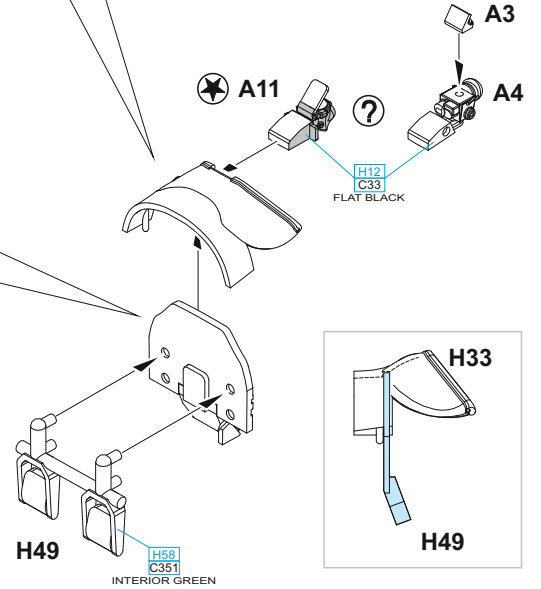

H58 - MARKINGS **A, B, E, F, H, I, J**

H59 - MARKINGS **C, D, G**

OPTIONAL:

decals K2, K6, K8, K9, K10 - MARKINGS **A, B, E, F, H, I, J**

decals K1, K7, K8, K9, K10 - MARKINGS **C, D, G**

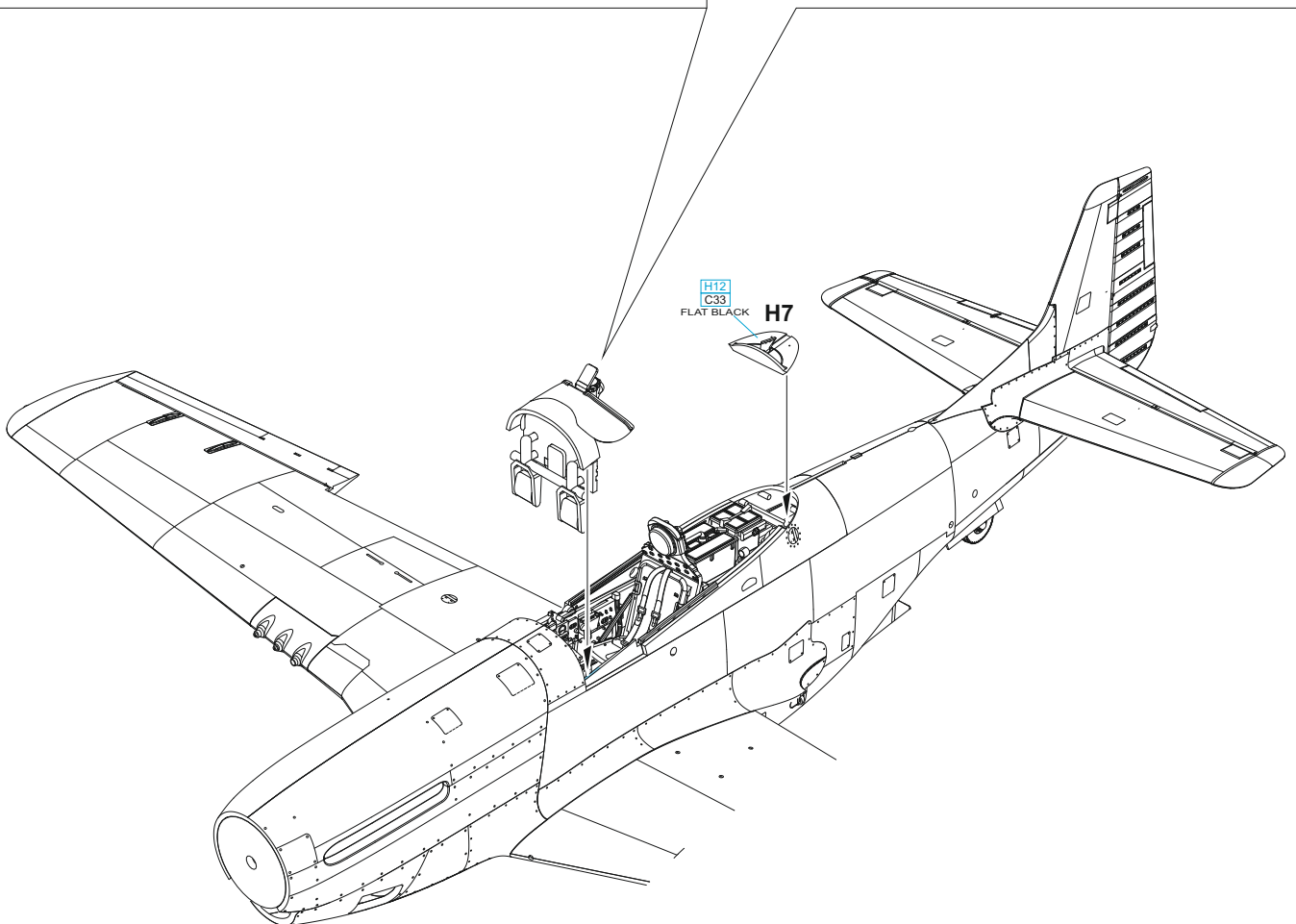

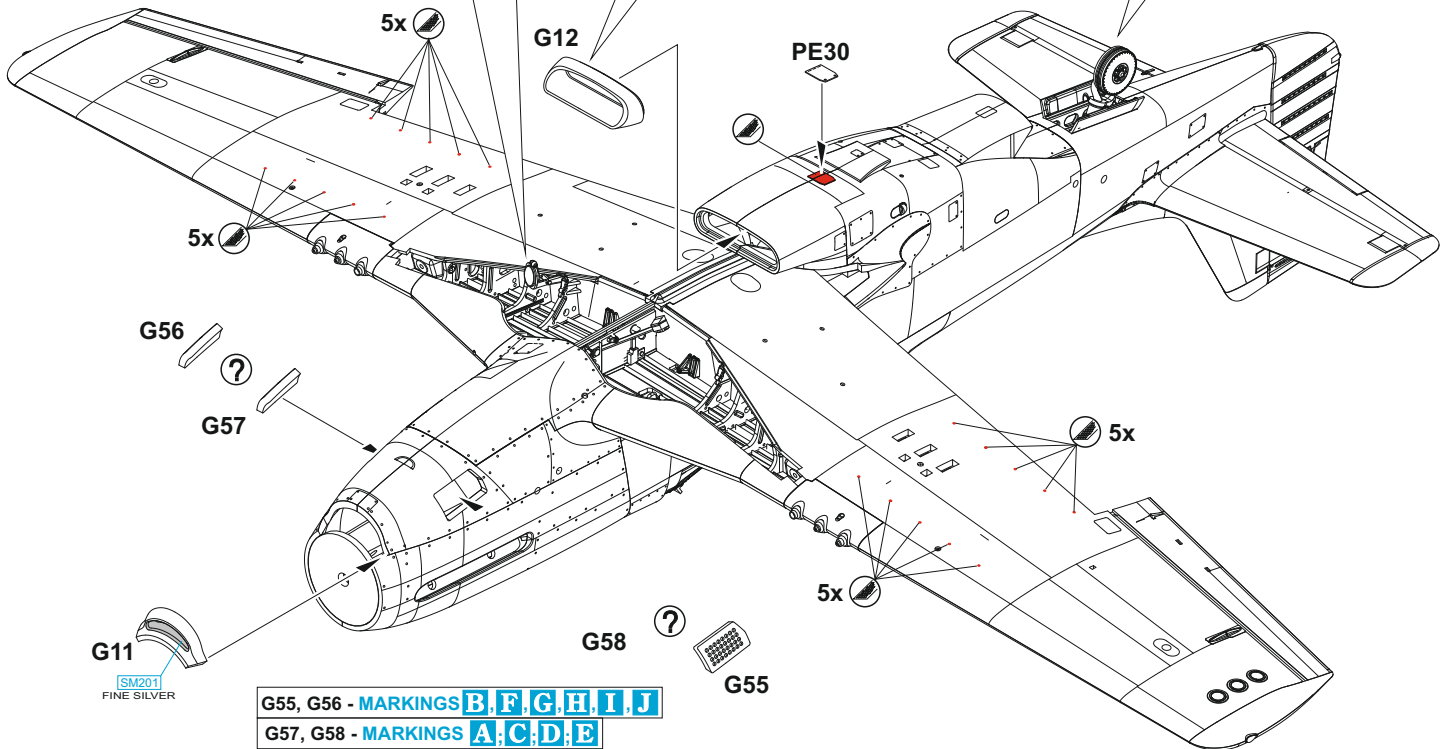
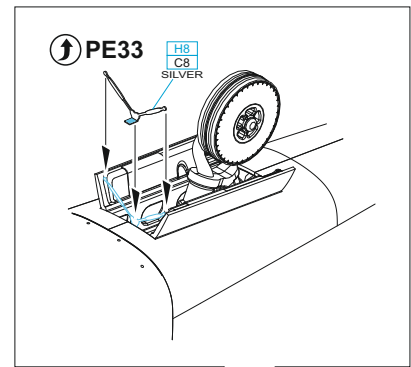
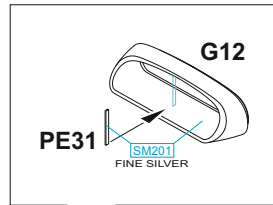
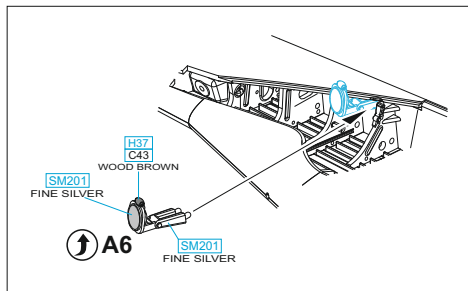
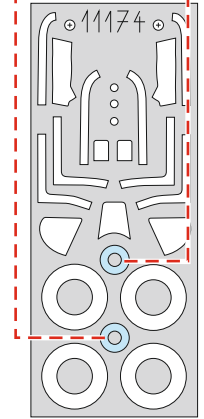
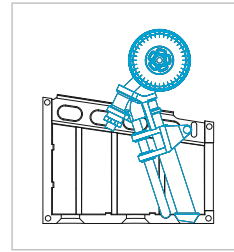
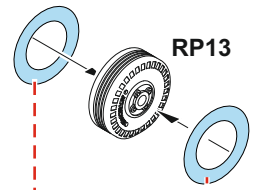
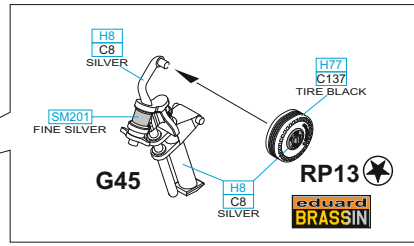
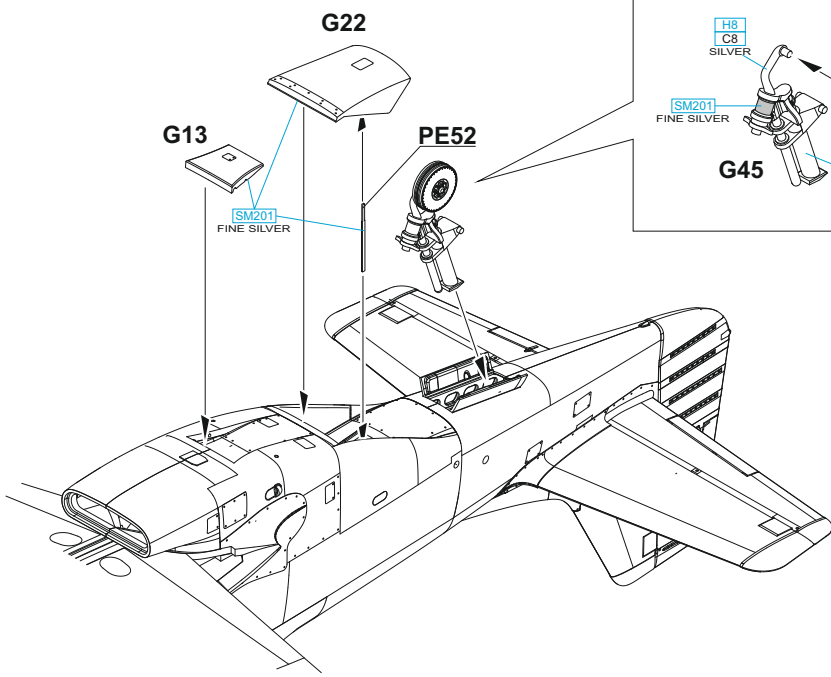

2 pcs.

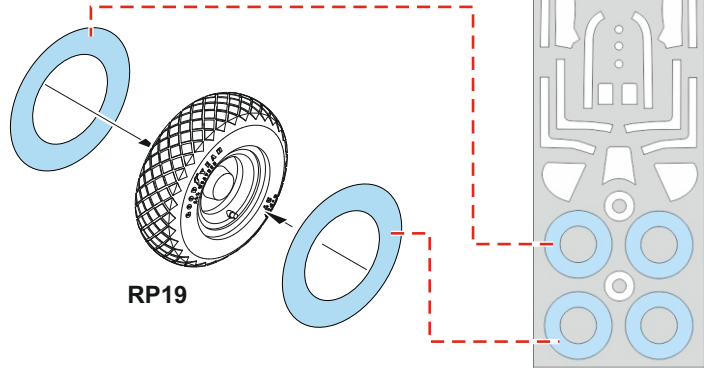
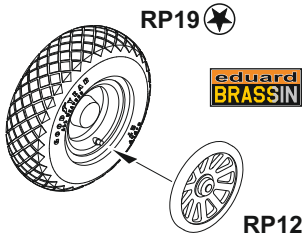

G

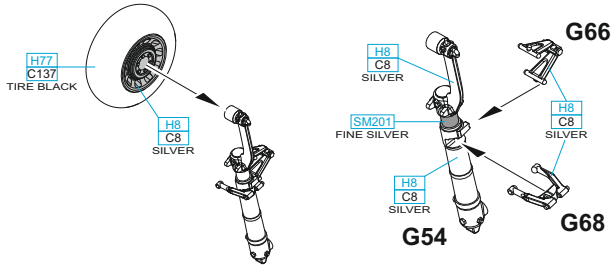

H

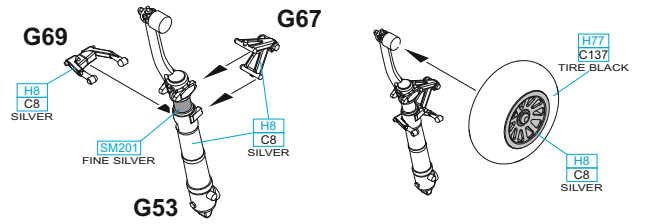

I

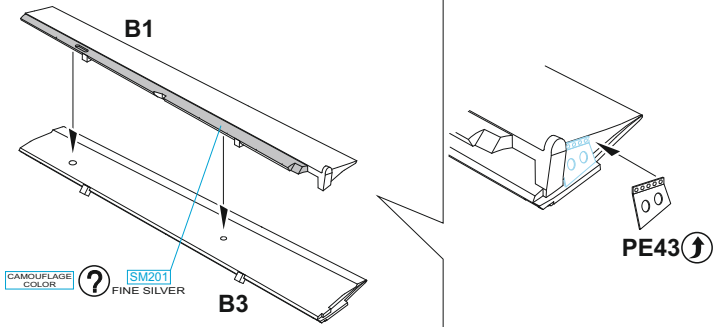

J

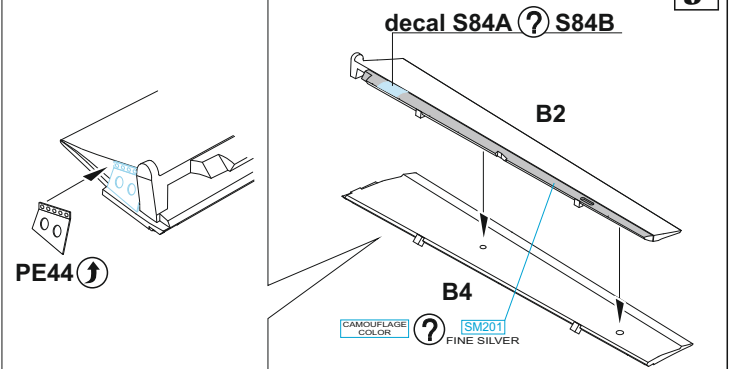

CAMOUFLAGE COLOR - MARKINGS I, J ONLY

CAMOUFLAGE COLOR - MARKINGS I, J ONLY

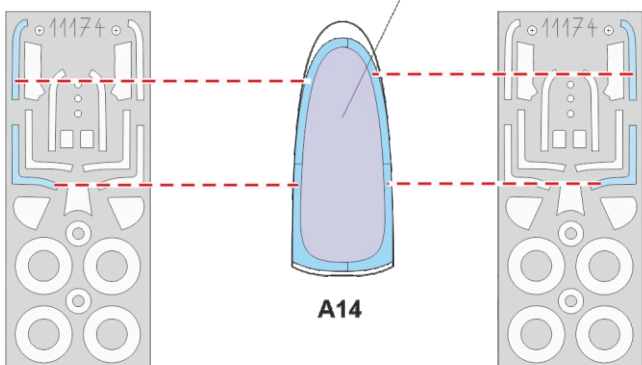
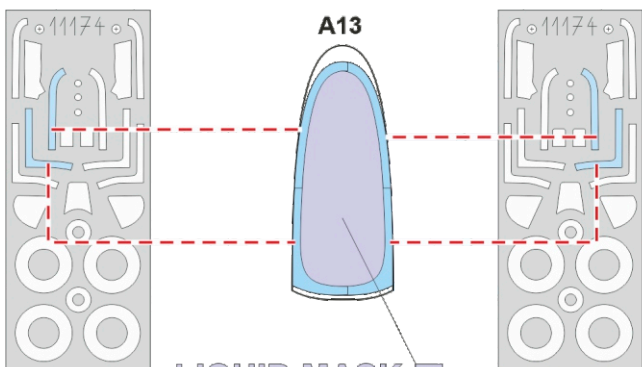

eduard
MASK
11174

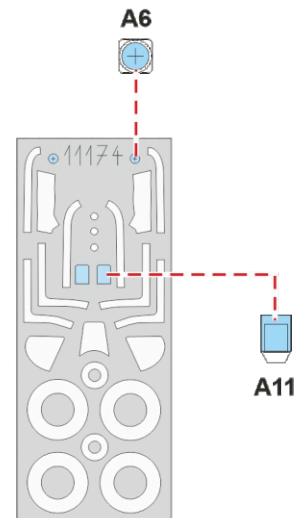

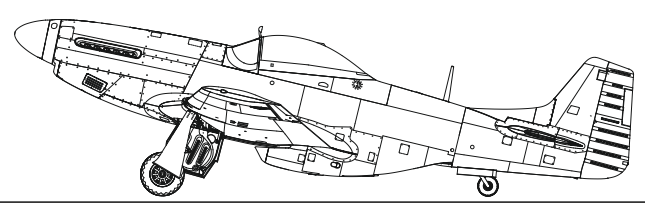
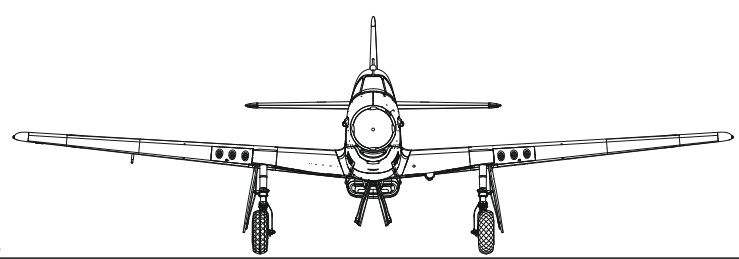
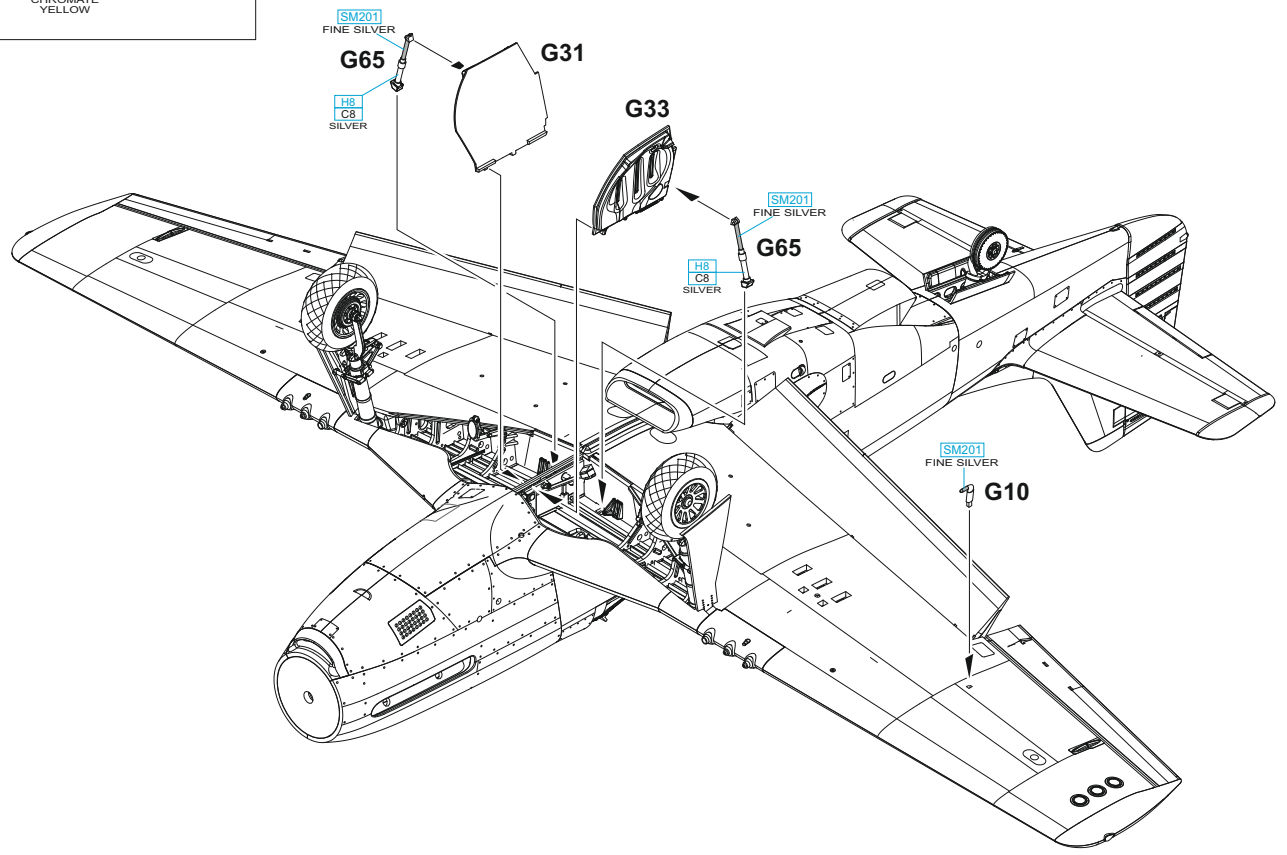
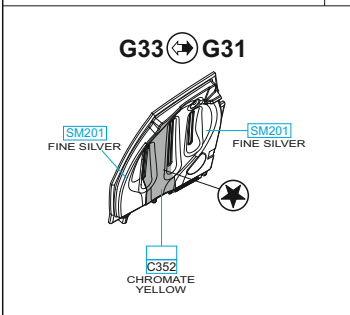
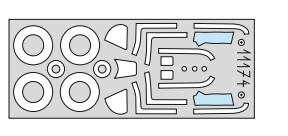
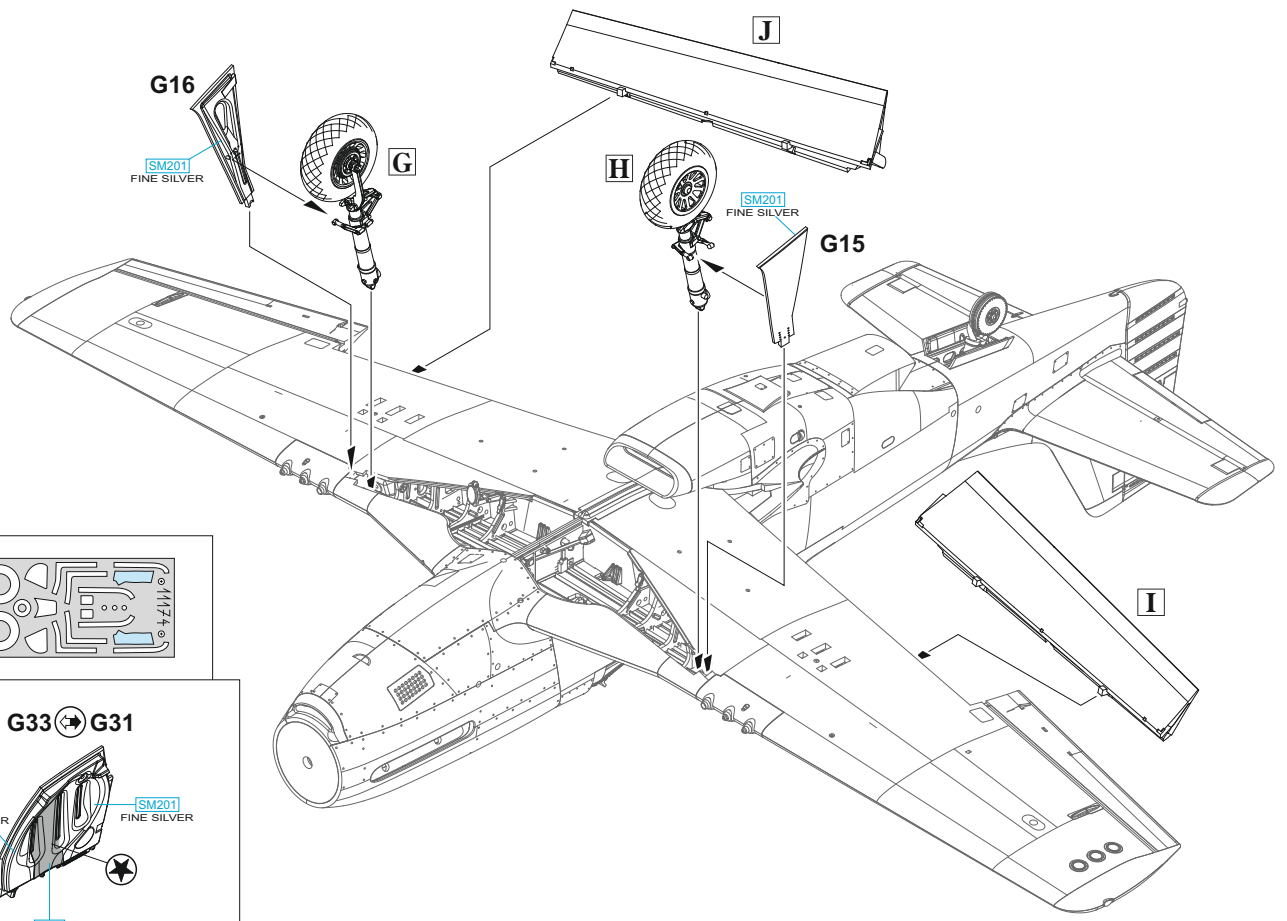

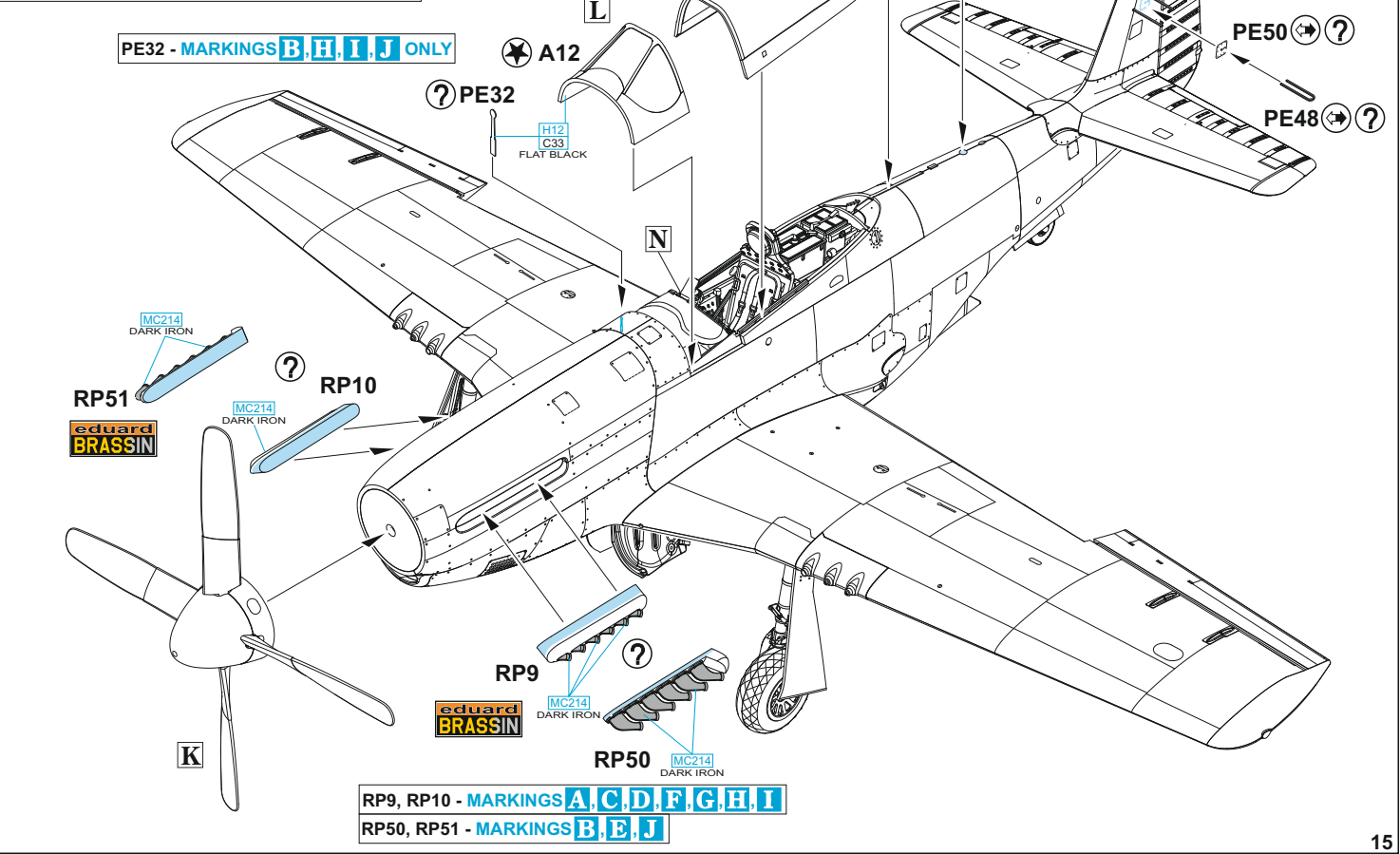
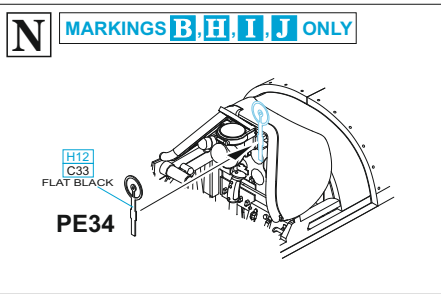
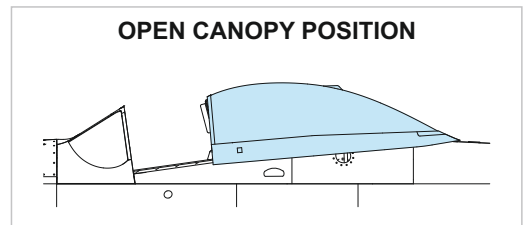
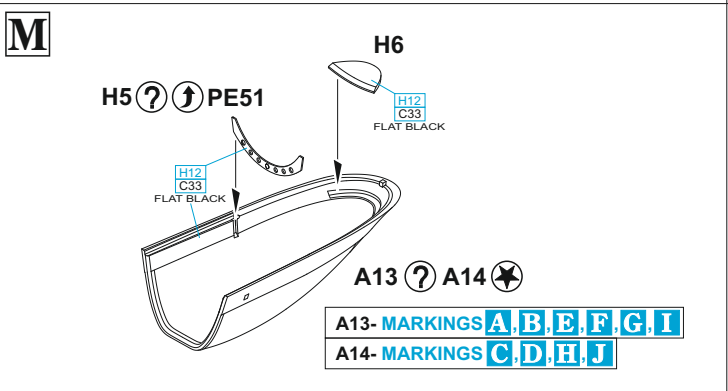
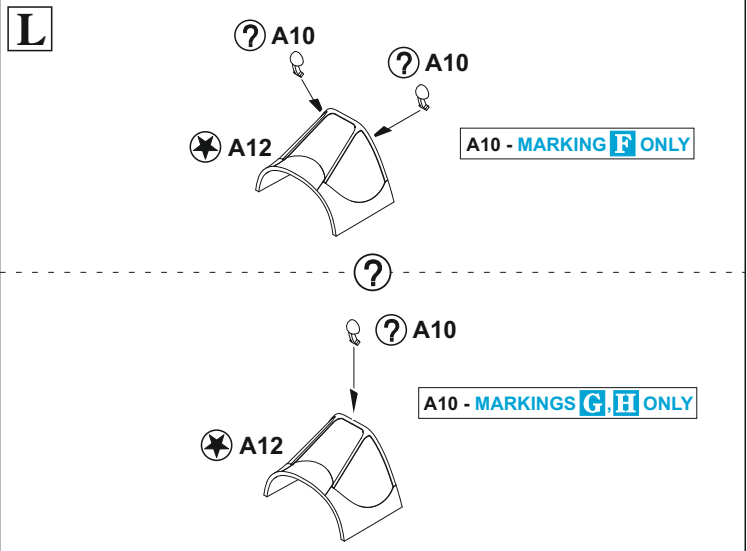
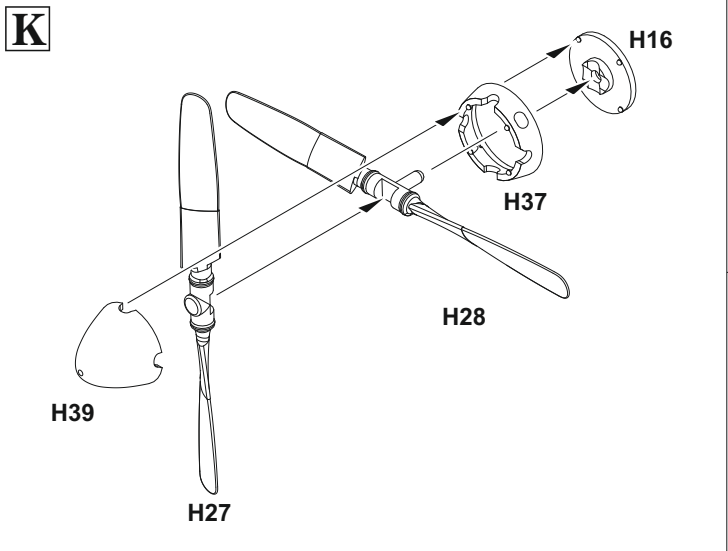

N 2 pcs.

O 2 pcs.

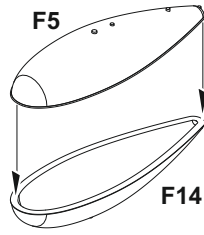
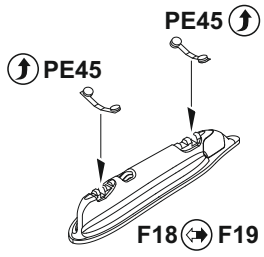

?

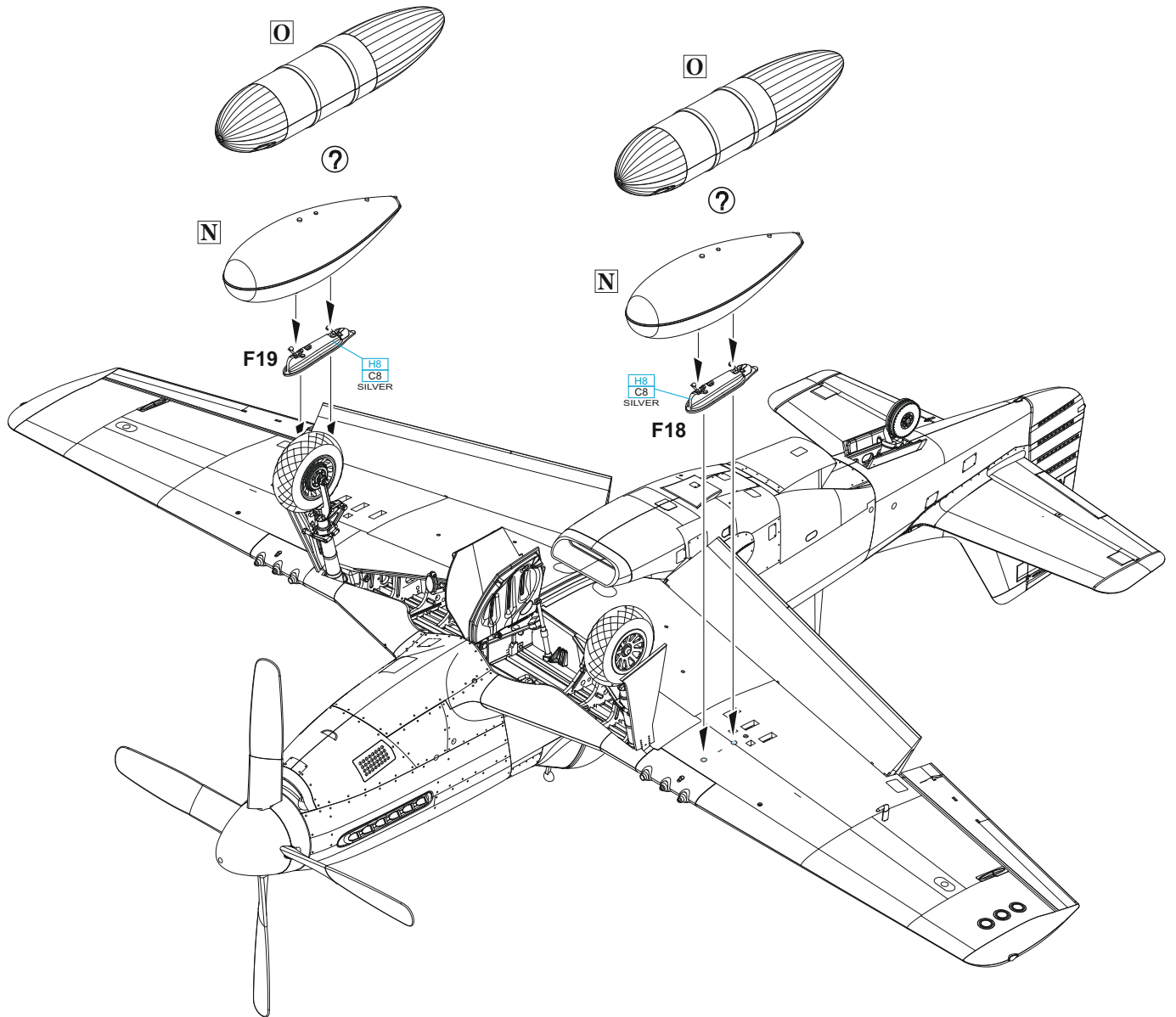
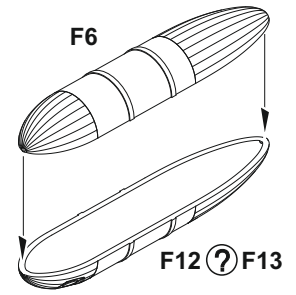

A P-51D-15, 44-15492, Lt. Billy Clemmons, 38th FS, 55th FG, 8th AF, Wormingford, United Kingdom, April 1945

Billy Clemmons started his pilot training in January 1943 and in February 1944 obtained his "wings". After he completed his training in August 1944 he was assigned to 38th FS, 55th FG. In the course of his war-time career he flew 62 combat missions and scored four and half air victories including one individual and one shared kill of the Me 262 jet. He destroyed five more aircraft on the ground. He decorated his personal Mustang with an Indian's head with inscription "Huacoar" on the port side of the nose and the starboard featured the inscription "My Gal Sal". During the Korean War Clemmons was called back to the active duty and attached to the 75th Fighter Inceptor Squadron which flew F-86 Sabre jets. Then he was ordered to the 513th FIS in England and France. After his return to the United States he was assigned to the Flight Training Headquarters as an instructor on T-37 and T-38. He attended several military schools, including the Air War College in Montgomery, Alabama. Consequently he was attached to the Department of the Chiefs of Staff in Pentagon, Washington D.C. and later took part in the introduction of the global military command and management system which was, in fact, the predecessor to the internet. After he finished his military career for several years he worked for Waco Hotel Supply and in the end he started his own restaurant equipment company, Clemco Restaurant Equipment Co.

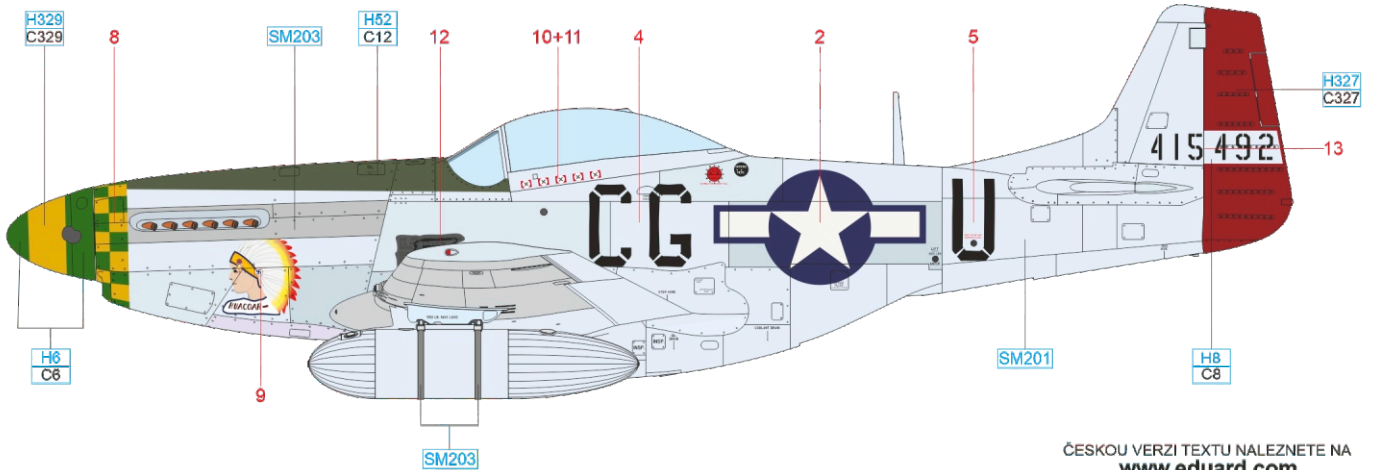

ČESKOU VERZI TEXTU NALEZNETE NA
www.eduard.com
 POD KATALOGOVÝM ČÍSLEM 11174

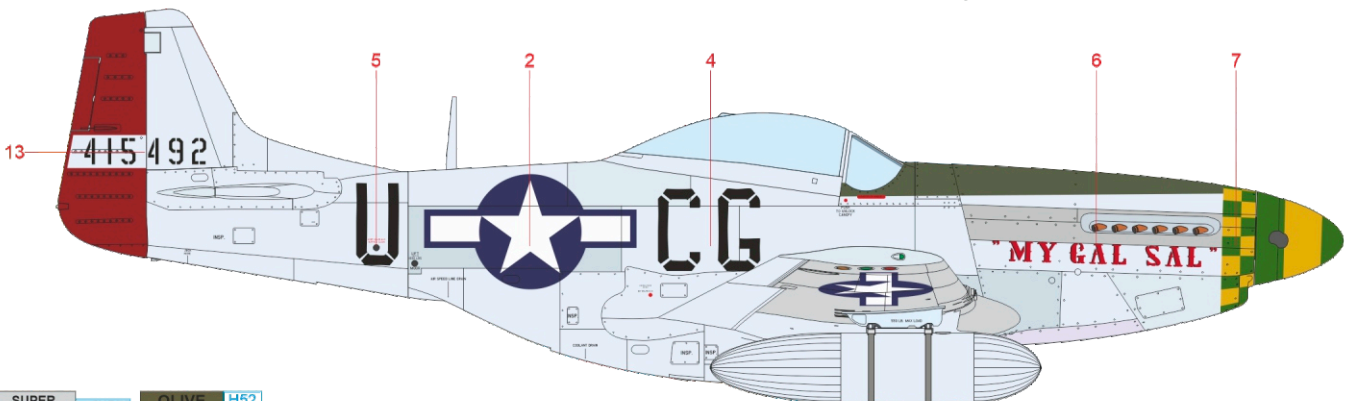
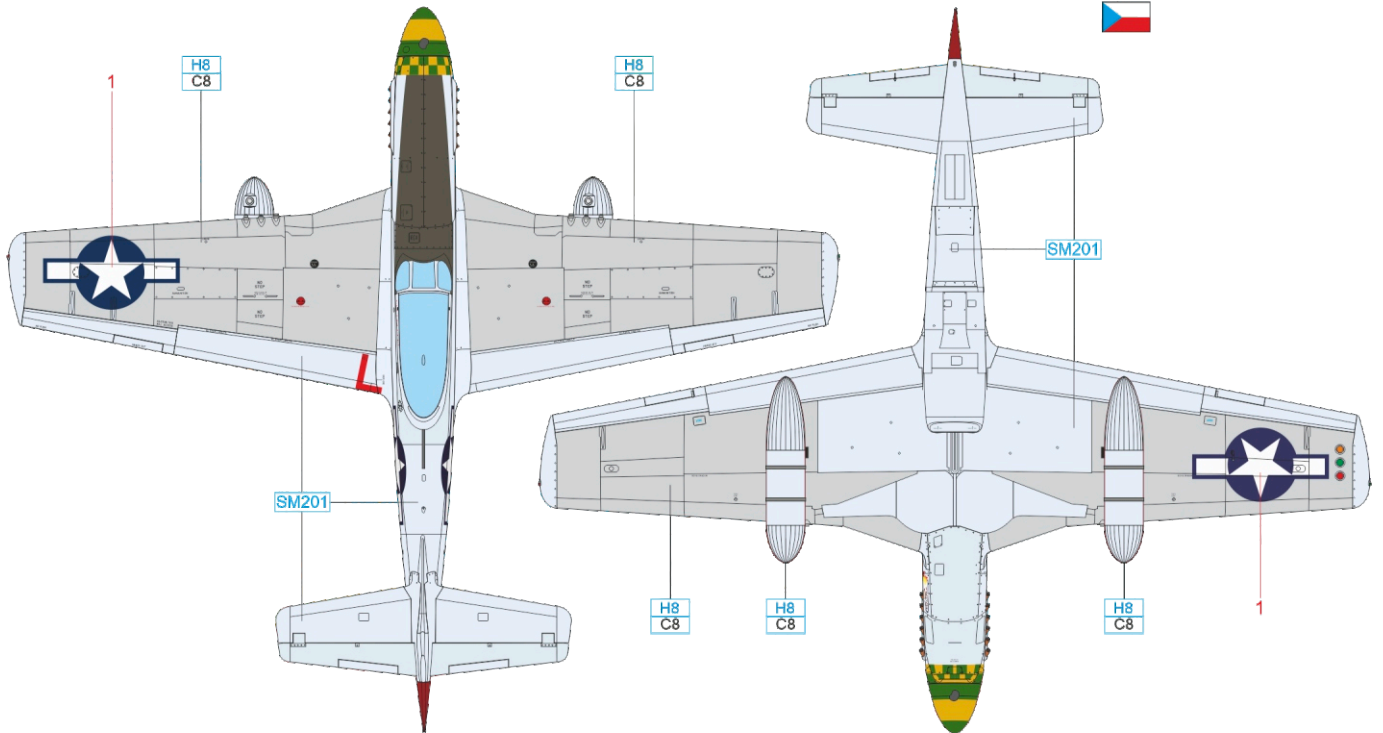

SUPER FINE SILVER 2	SM201	OLIVE DRAB	H52 C12
SUPER IRON 2	SM203	SILVER	H8 C8
		GREEN	H6 C6
		YELLOW	H329 C329
		RED	H327 C327

B P-51D-15, 44-14985, Maj. Edward B. Giller, 343rd FS, 55th FG, 8th AF, Wormingford, United Kingdom, September 1944

Edward Giller was born in Jacksonville, Illinois, in 1918. He graduated from the Kemper Military School in Boonville, Missouri and in 1940, the University of Illinois with BS in chemical engineering. In September 1941 he joined the military and at the same time the pilot school where he gained his wings in April 1942. During WWII he commanded the 343rd FS and later became the deputy commander of the 55th FG. As a fighter pilot he flew 115 combat missions and logged 465 hours in P-38 and P-51. He destroyed three enemy aircraft, including Me 262 jet and six more airplanes on the ground. Giller flew two Mustangs, s/n 44-14985 and s/n 44-15701. Both of his Mustangs were christened "Millie G" after his wife Mildred who was a flight attendant. Giller's Mustang sported the standard 343rd FS marking i.e. black prancing horse on the yellow rudder. After the war, in 1948, he obtained MS in the chemical engineering and in 1950 a doctorate in the chemical engineering. He served as an executive director of the Weapons Effect Division center. After that he became an assistant director and then director of the research at the Air Force Special Weapons Center at Kirtland airbase where he also acted as a USAF liaison officer in the Orion, nuclear spaceship project. He passed away in October 2017 at the age of 99.

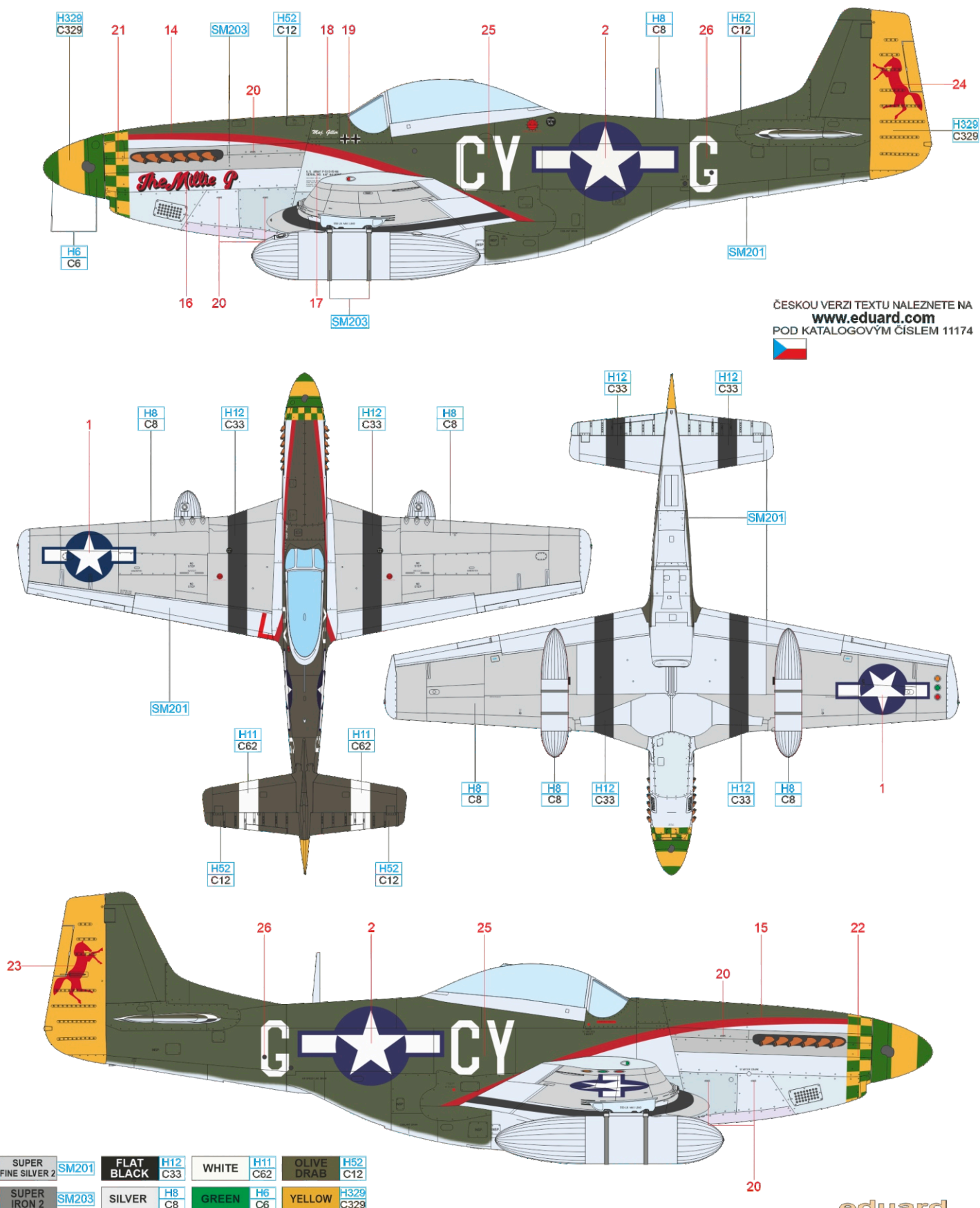

Richard A. "Dick" Hewitt joined the 78th FG based at Duxford in September 1943 and flew with this unit until the end of hostilities. The unit operated P-47 but in December 1944 converted to P-51D Mustang and in the end of that month already flew its first mission with them. Hewitt logged 20 missions flying this type out of his total 100 missions. On March 21, 1945, he assumed command of the 82nd FS after he had shot down three Bf 109 two days earlier. On April 17 he destroyed a Me 262 on the ground after he had shot down another Schwalbe shortly before the landing at the Lechfeld airfield. This kill however remained unconfirmed because his wingman, the only witness to this kill, was consequently shot down and became POW. Hewitt ended the war after two tours of duty during which he logged 426 hours. Official Hewitt's score was four aerial victories plus four individual and one shared enemy aircraft destroyed on the ground. During his second tour of duty, Dick was promoted to the 82nd FS commander. His awards include Silver Star, four DFC and 13 Air Medals. The inscription "Big Dick" on his Mustang refers to Hewitt's nickname. After the war he wrote a book "Target of Opportunity."

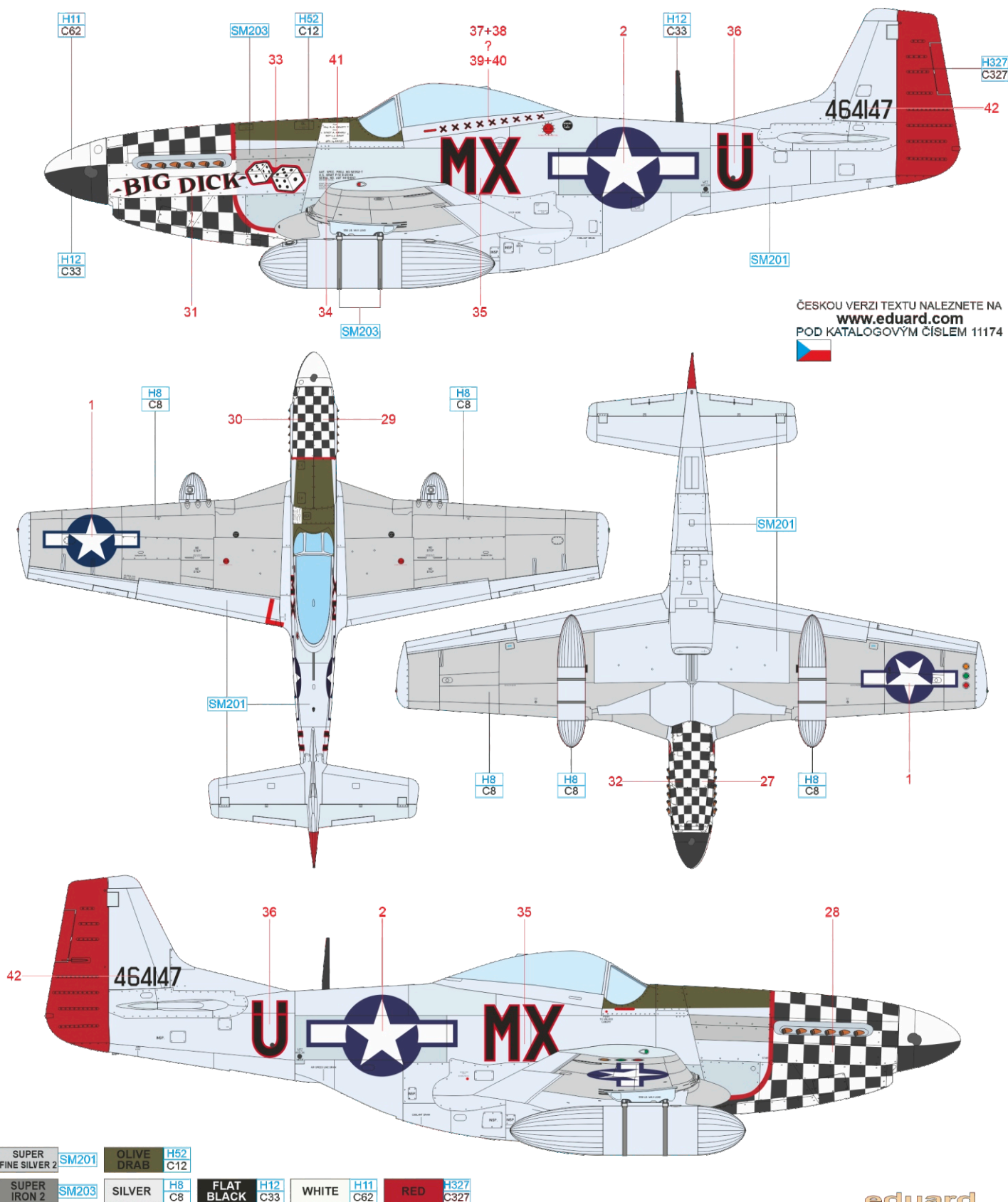

D P-51D-20, 44-72218, Lt Col. John D. Landers, CO of 78th FG, Duxford, United Kingdom, March 1945

John Dave Landers was born on August 23, 1920, in Joshua, Texas. He joined the Army Air Force in April 1941. After completing the pilot training, In January 1942 he was assigned to the 9th FS in Australia, a unit that flew P-40s. In the Pacific theatre, he scored six kills, and in January 1943, he was called back to the States. There, he served as a flight instructor, but in April 1944, on his own request, was reassigned to a combat unit. It was 38th FS based at Wormingford, operating P-38, which converted to P-51 as of July 1944. After being promoted to Lt. Col., he assumed command of the 357th FG, which he led from October to December 1944. After some downtime in the United States, he returned to Great Britain and was named CO of 78th FG, holding this post until the end of the Second World War. In December 1945, he left the military and worked in construction. He died on September 12, 1989.

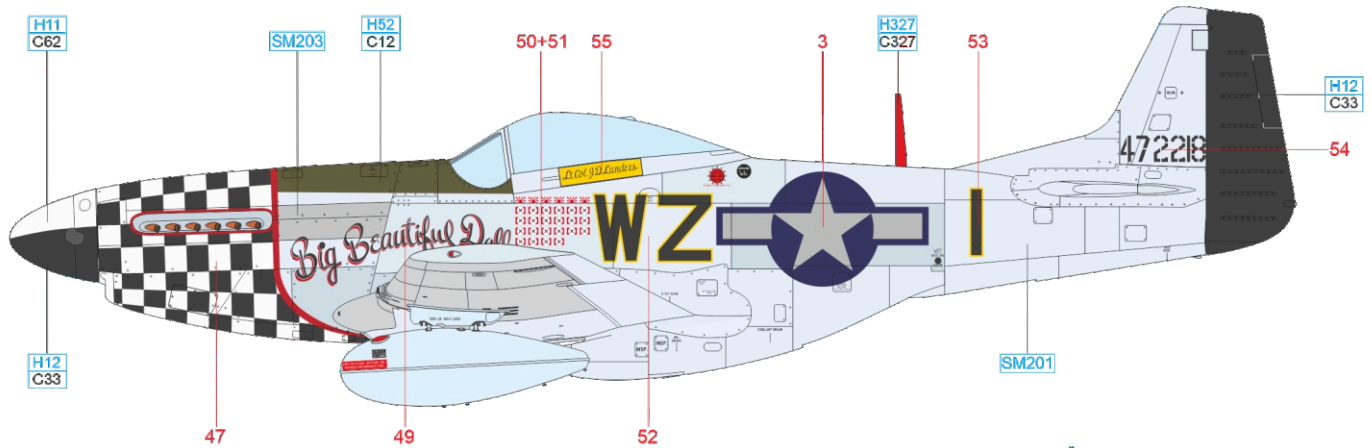

ČESKOU VERZI TEXTU NALEZNETE NA
www.eduard.com
 POD KATALOGOVÝM ČÍSLEM 11174

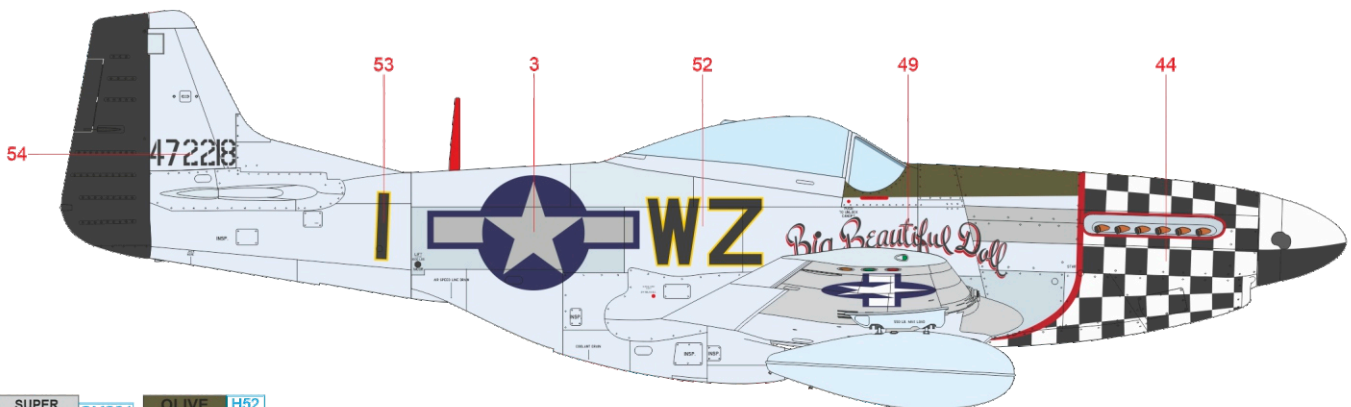
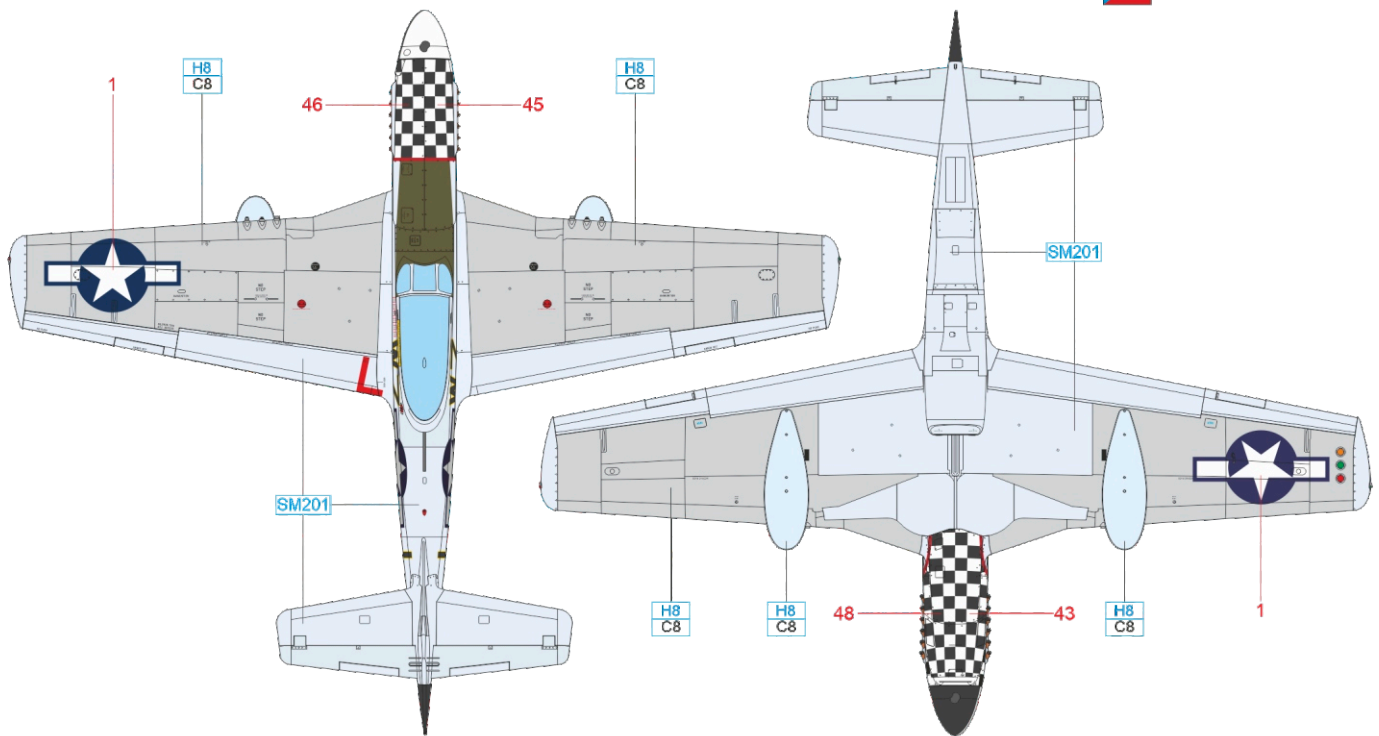

SUPER FINE SILVER 2	SM201	OLIVE DRAB	H52 C12
SUPER IRON 2	SM203	SILVER	H8 C8
		FLAT BLACK	H12 C33
		WHITE	H11 C62
		RED	H327 C327

E P-51D-10, 44-14372, Capt. Kirk B. Everson, 504th FS, 339th FG, 8th AF, Fowlmere, United Kingdom, April 1945

Everson's airwar career took off in 1945 only. Regardless, he achieved great successes in the numerous diving strikes on the German-occupied airfields. Mustang he regularly flew was inherited from Richard C. Penrose who had christened it "Beaver Chant". Everson renamed it "Mary Beth". On April 4, 1945 he shared a victory over Me 262 above Parchim. Three days later he shot down a Bf 109 nearby Celle. On April 10, during the strafing attack on the Neuruppin airfield, he destroyed three enemy aircraft and on April 16 three Fw 190 fell victims to his guns at Klatovy airfield. On the following day Everson re-appeared over the Klatovy airfield and this time he claimed the destruction of seven airplanes.

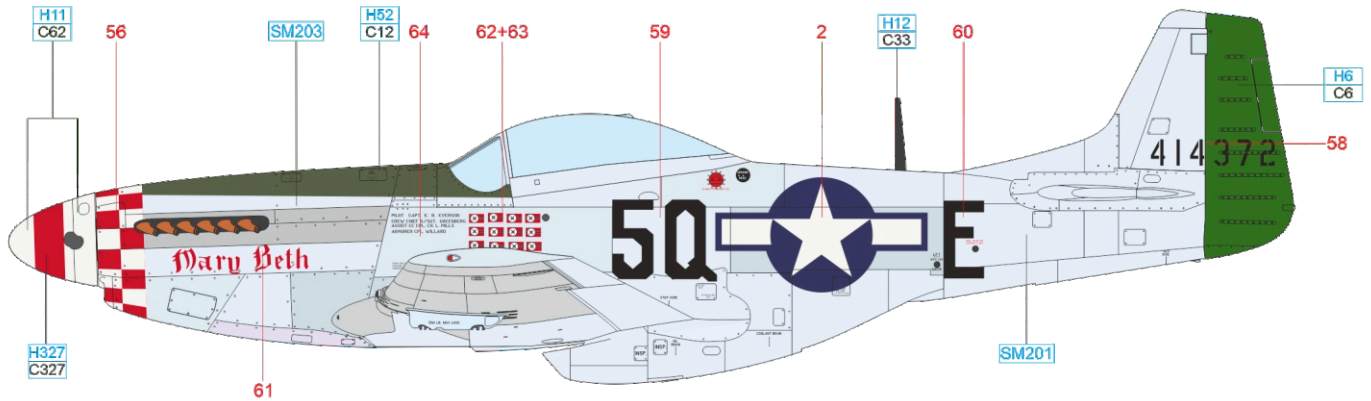

ČESKOU VERZI TEXTU NALEZNETE NA www.eduard.com
POD KATALOGOVÝM ČÍSLEM 11174

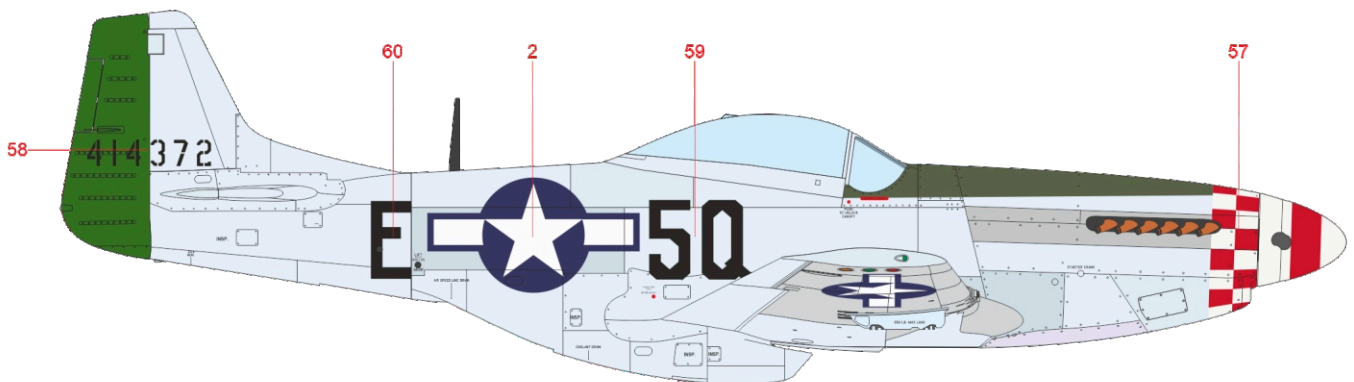
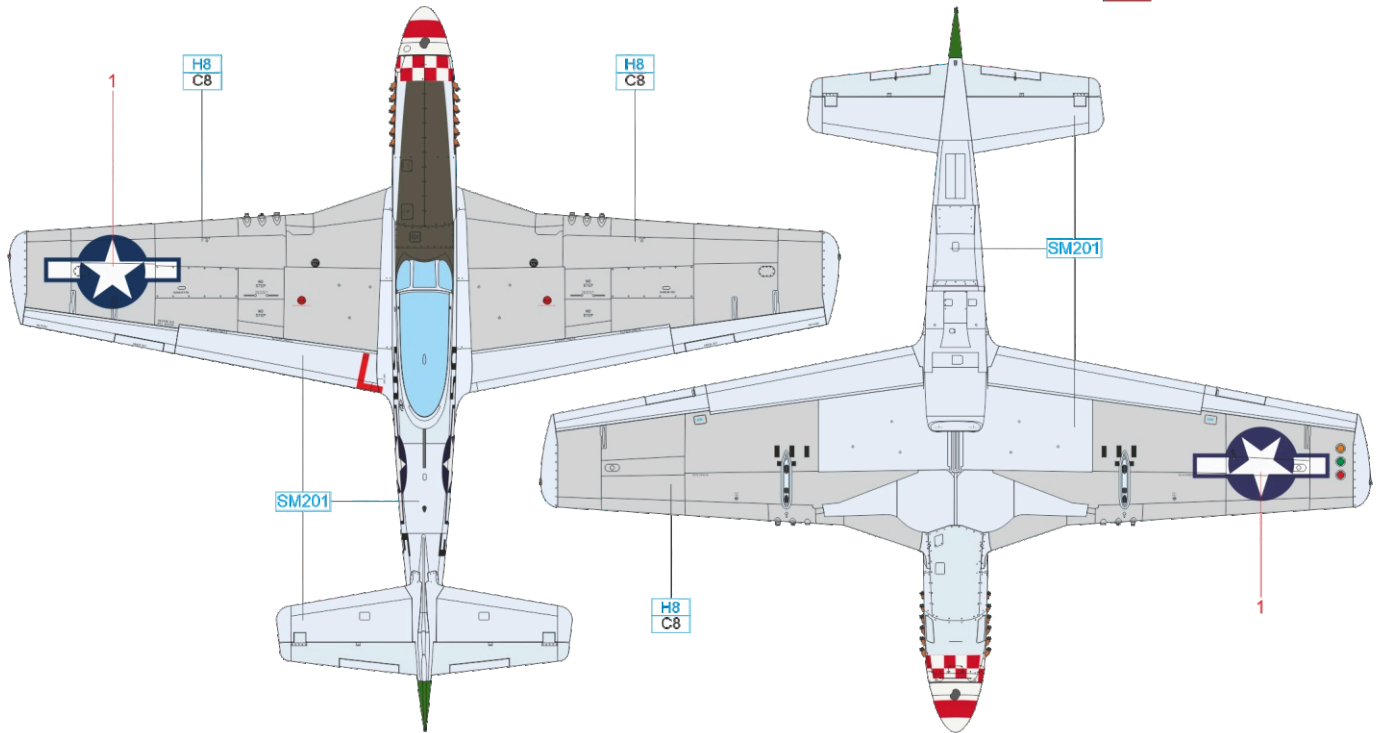

SUPER FINE SILVER 2	SM201	OLIVE DRAB	H52 C12	GREEN	H6 C6
SUPER IRON 2	SM203	SILVER	H8 C8	FLAT BLACK	H12 C33
		WHITE	H11 C62	RED	H327 C327

F P-51D-10, 44-14419, Capt. William B. Price, 350th FS, 353rd FG, 8th AF, Raydon, United Kingdom, December 1944

Bill Price was a member of the 350th FS, 353rd FG from November 1942 till December 1944 and flew with it 108 missions in two tours of duty. Flying P-47 he achieved two aerial victories and four on the ground. After the unit converted to new P-51D Mustang he scored his last kill at the controls of the aircraft named "Janie". Price's Mustang was camouflaged with a green paint on the upper surfaces, probably British Dark Green. The aircraft nose sported the black and white checkerboard, identification marking of the 353rd FG.

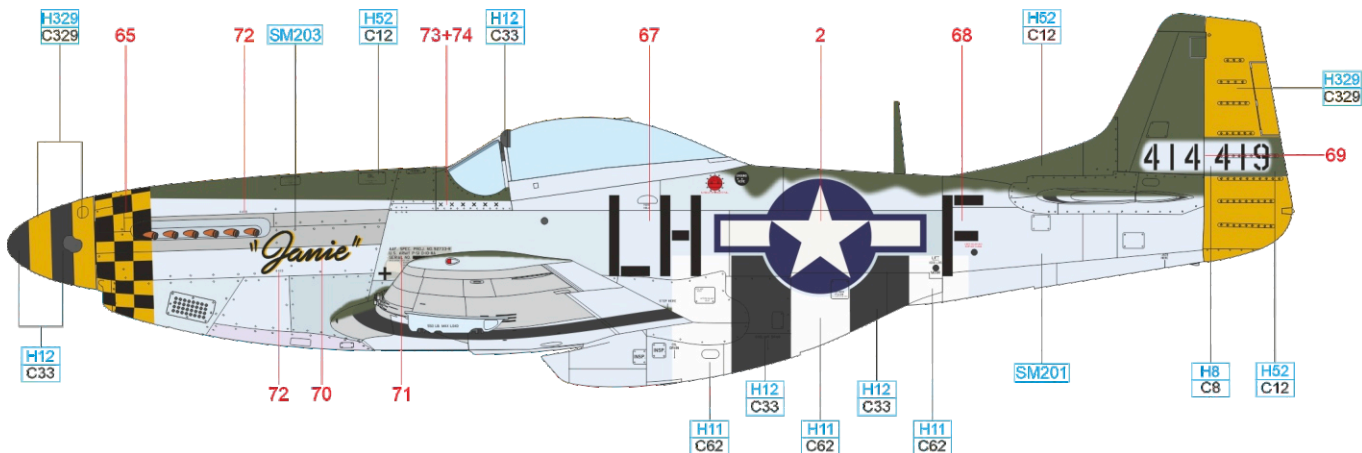

ČESKOU VERZI TEXTU NALEZNETE NA
www.eduard.com
 POD KATALOGOVÝM ČÍSLEM 11174

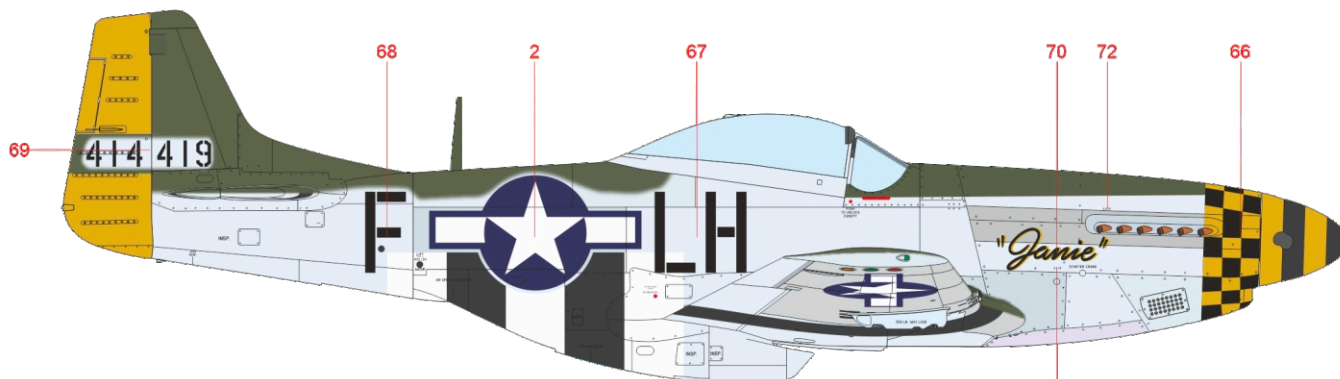
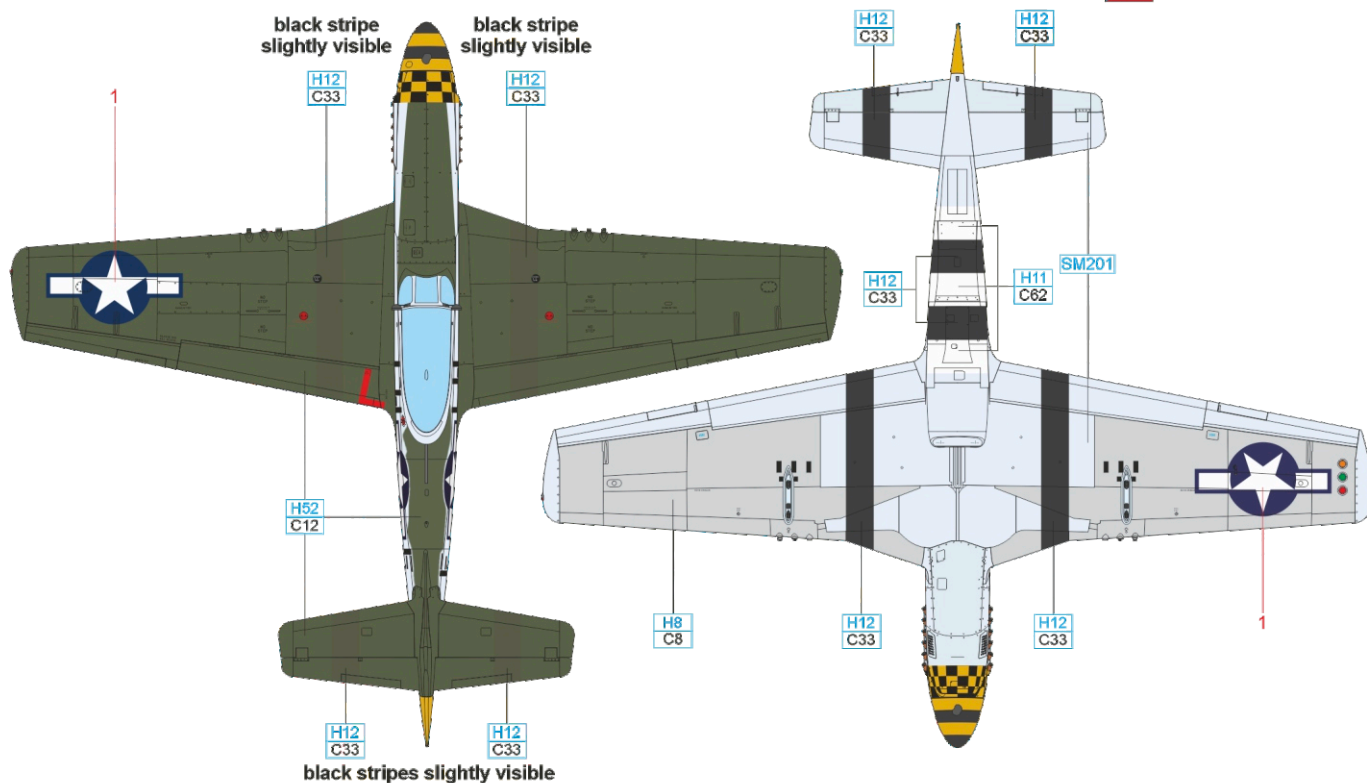

SUPER FINE SILVER 2	SM201	OLIVE DRAB	H52 C12	WHITE	H11 C62
SUPER IRON 2	SM203	SILVER	H8 C8	FLAT BLACK	H12 C33
				YELLOW	H329 C329

Lt. William Bradford Bailey commanded the 352nd FS since its formation in October 1942 until July 7, 1944 and in the end of the war he was one of the most experienced pilots of the unit. After his long tenure with 352nd FS, he was transferred to the 353rd FG Headquarters and until the end of the conflict he flew in total 186 missions (454.05 flight hours). On March 2, 1945, at the controls of his Mustang named "Double Trouble Two" he claimed two Fw 190 destroyed south of Wittenberg. These were last Bailey's kills of the war. His final score stood at three aerial and three ground victories.

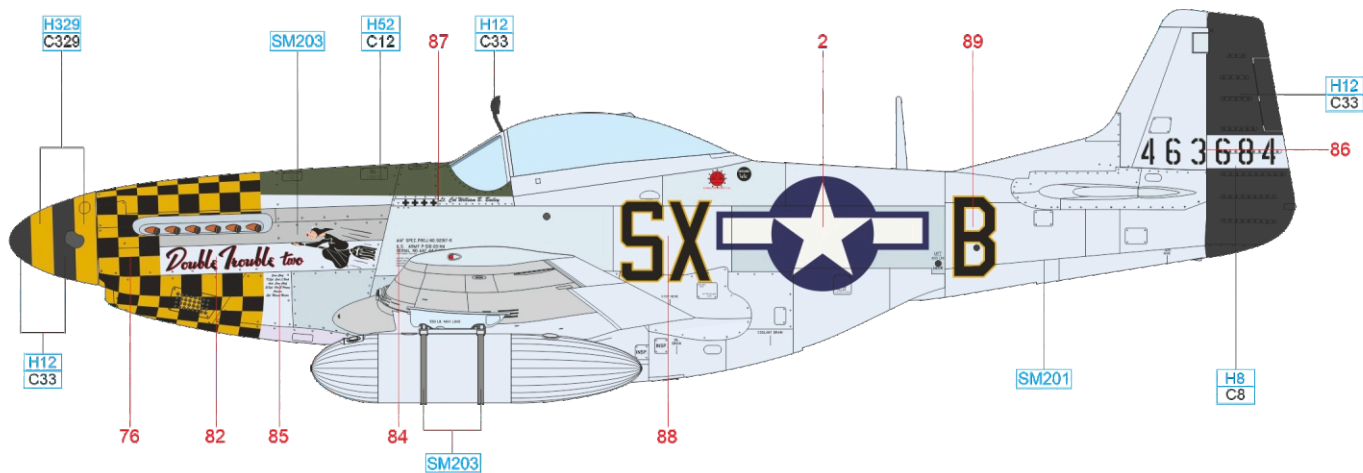

ČESKOU VERZI TEXTU NALEZNETE NA
www.eduard.com
 POD KATALOGOVÝM ČÍSLEM 11174

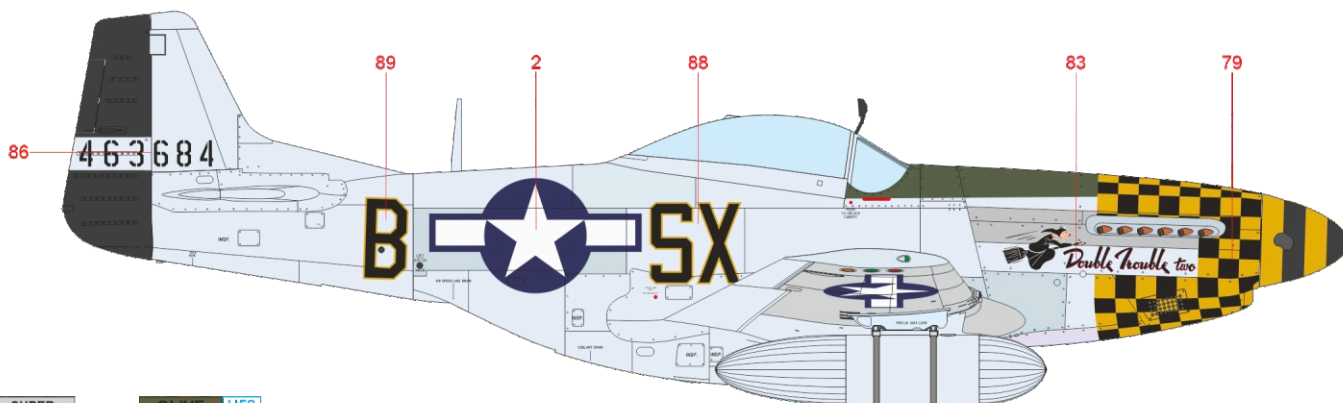
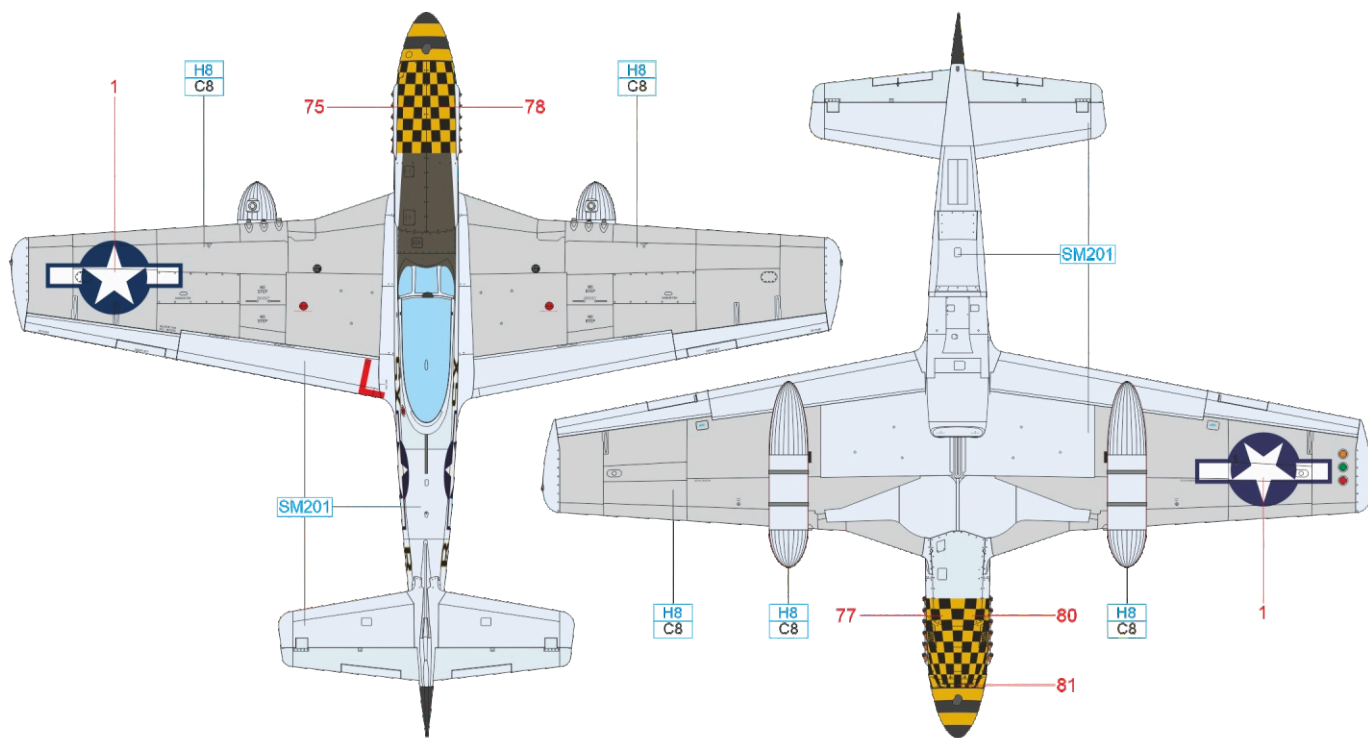

SUPER FINE SILVER 2	SM201	OLIVE DRAB	H52
SUPER IRON 2	SM203	SILVER	H8 C8
		FLAT BLACK	H12 C33
		YELLOW	H329 C329

H P-51D-10, 44-14896, Maj. Leonard K. Carson, 362nd FS, 357th FG, 8th AF, Leiston, United Kingdom, September 1944

Captain Leonard "Kit" Carson was one of the most successful pilots of the 357th FG. He finished the war as a commander of the 363rd FS with 18,5 kills to which he added three airplanes destroyed on the ground. He flew four P-51 Mustangs, all of them carried his personal inscription "Nooky Booky" on the engine cowling. The aircraft s/n 44-14896 was his third. It sported seven kill markings on the side of the fuselage which Carson scored till the beginning of November 1944. The plane was marked with the standard identification stripes including the invasion bands on the fuselage. Carson's Mustang was camouflaged in the dark green paint on the upper surfaces including the landing flaps' interiors. The paint was probably British RAF Dark Green. The lower surfaces were painted in Medium Sea Grey.

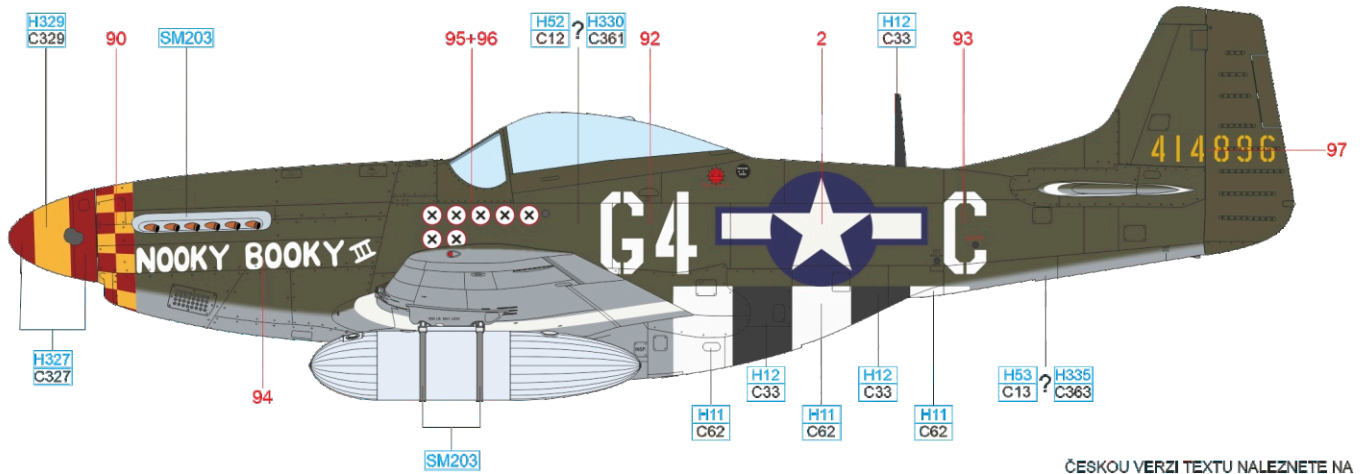

ČESKOU VERZI TEXTU NALEZNETE NA
www.eduard.com
 POD KATALOGOVÝM ČÍSLEM 11174

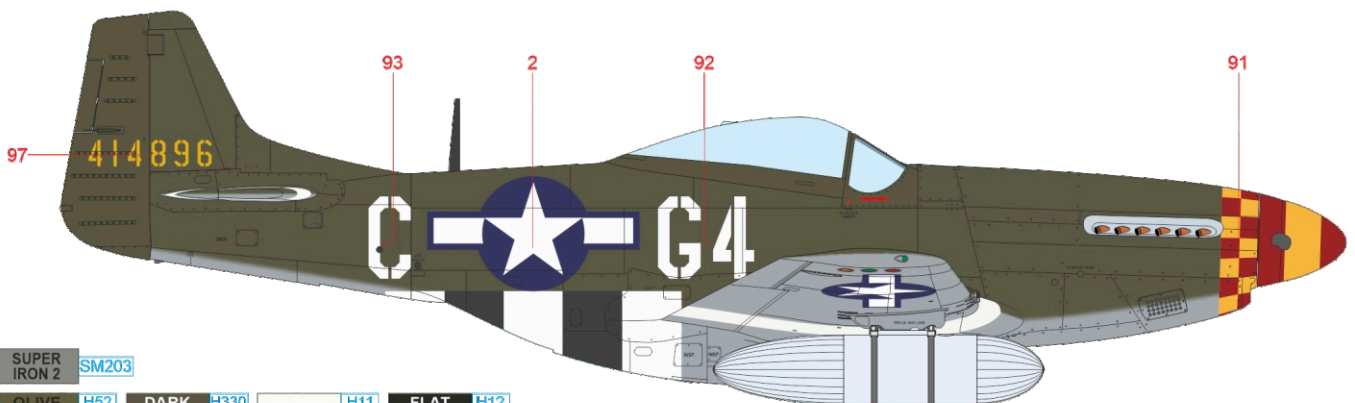
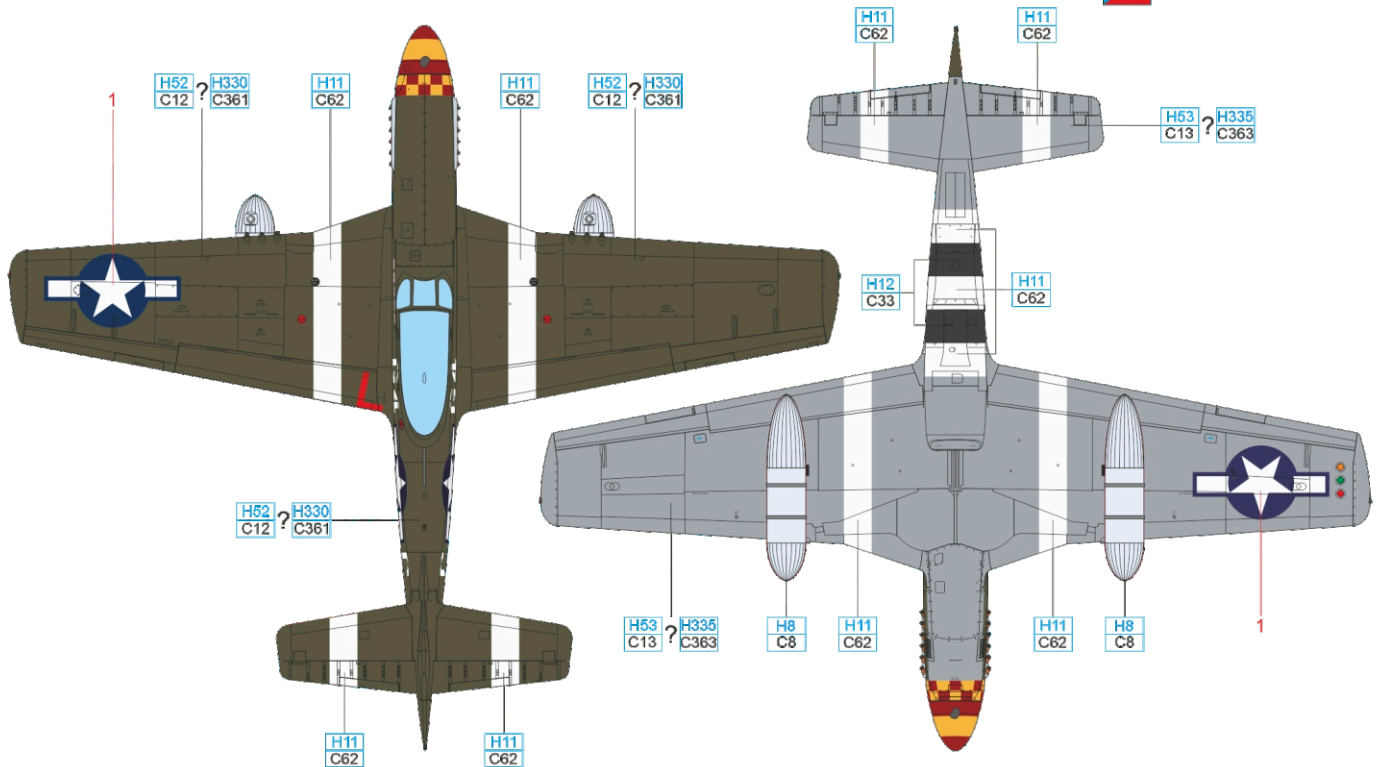

SUPER IRON 2	SM203				
OLIVE DRAB	H52 C12	DARK GREEN	H330 C361	WHITE	H11 C62
				FLAT BLACK	H12 C33
NEUTRAL GRAY	H53 C13	MEDIUM SEAGRAY	H335 C363	SILVER	H8 C8
				YELLOW	H329 C329
				RED	H327 C327

P-51D-10, 44-14450, Capt. Clarence E. Anderson, 363rd FS, 357th FG, 8th AF, Leiston, United Kingdom, October 1944

"Bud" Anderson was born on January 13, 1922 in Oakland, California. In January 1942 he joined the Army and till September 28, 1942 served as an Air Cadet. In November 1943 he was assigned to the 363rd FS, 357th FG. He finished his first tour of duty in June 1944 and returned to the United States for two months. In September 1944 he returned to his original unit. In the beginning of December 1944 he was promoted to Major and in January 1945 finished his second tour of duty. In total he flew 116 combat missions and logged 1423 flight hours. His final score was 17 confirmed aerial victories. After the war he mostly flew as a test pilot and he retired from the Air Force on March 31, 1972. Mustang flown by Clarence "Bud" Anderson during his second tour was initially camouflaged on all upper surfaces, including the landing flaps interiors, in dark green paint, probably RAF Dark Green. The lower surfaces were painted in Medium Sea Grey. In the end of 1944 Bud had camouflage paint removed from his Mustang and flew it in the natural metal finish. "Bud" Anderson named his new Mustang the same as the previous ones, "Old Crow" and shot down in it four more German aircraft. After he finished his second tour of duty, his "Old Crow" was handed over to Lt. James Taylor from the 363rd FS and renamed "Pretty Pix". After the war the aircraft was transferred to Neubiberg air base in Germany where it ended up as a scrap metal.

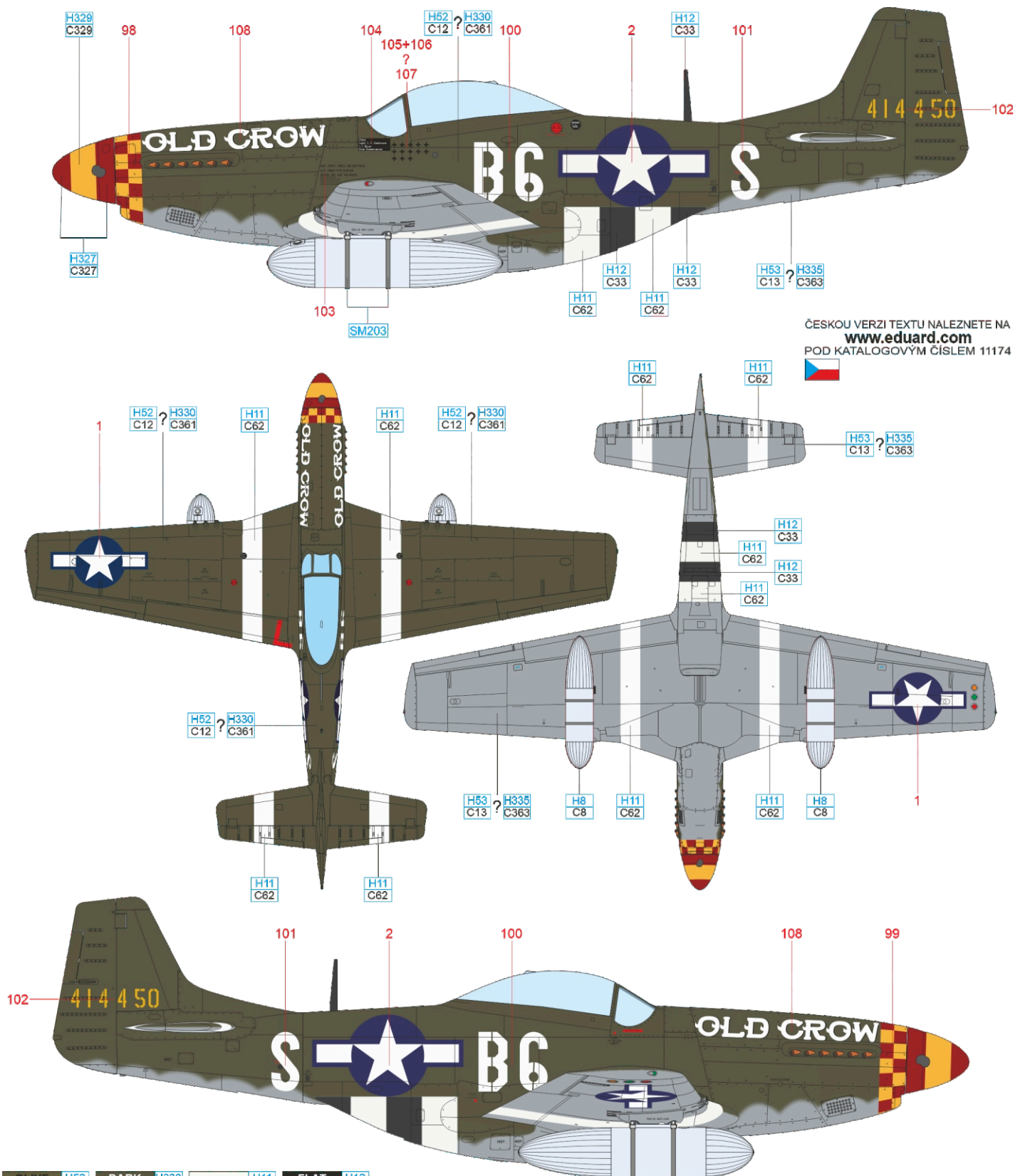

ČESKOU VERZI TEXTU NALEZNETE NA
www.eduard.com

POD KATALOGOVÝM ČÍSLEM 11174

OLIVE DRAB	H52 C12	DARK GREEN	H330 C361	WHITE	H11 C62	FLAT BLACK	H12 C33
NEUTRAL GRAY	H53 C13	MEDIUM SEAGRAY	H335 C363	SILVER	H8 C8	YELLOW	H329 C329
						RED	H327 C327
						SUPER IRON 2	SM203

P-51D ALUMINIUM LACQUER PAINTED AREAS

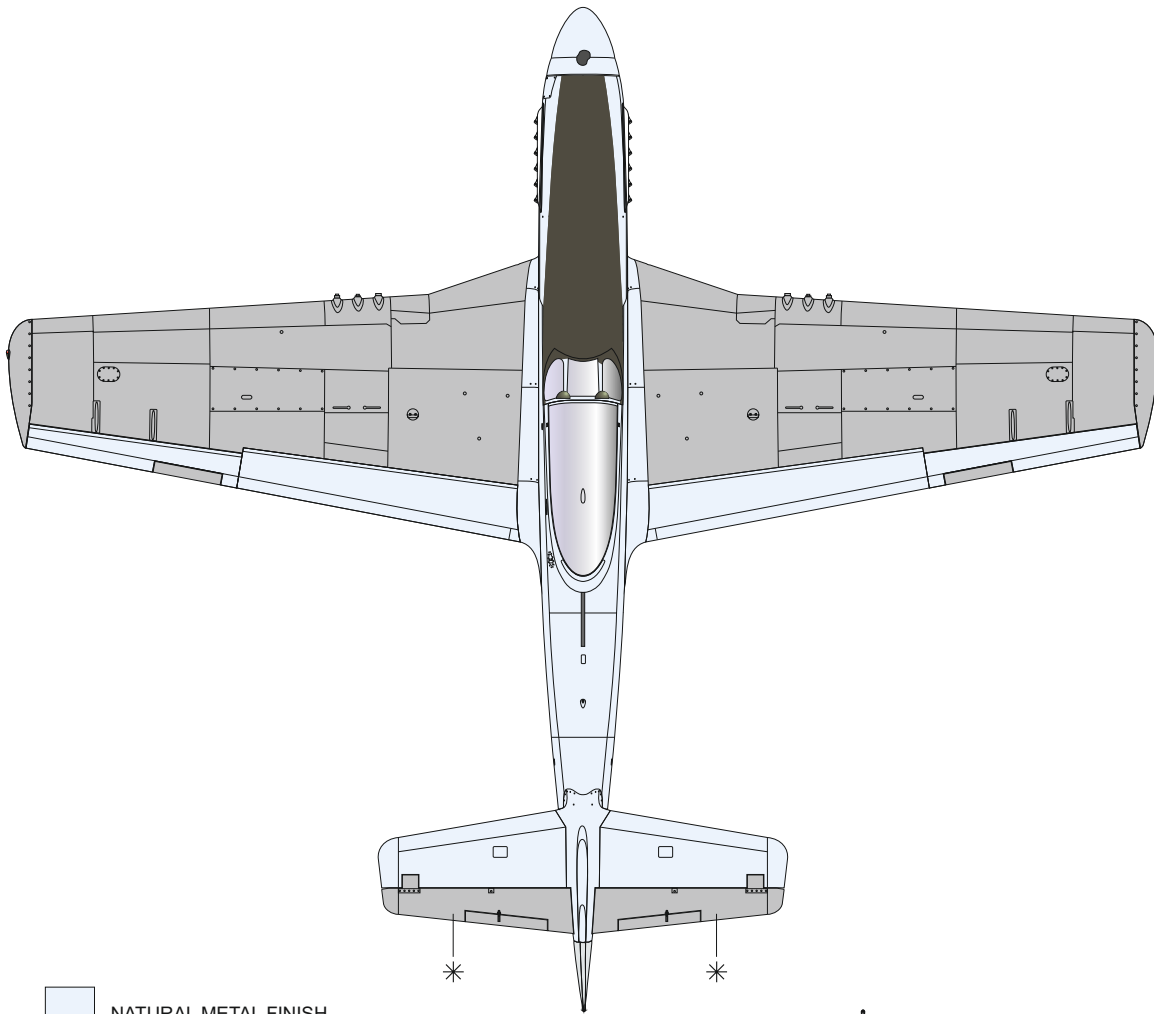

 NATURAL METAL FINISH

 ALUMINIUM LACQUER

* FOR FABRIC COVERED ELEVATORS

