

# SOVIET FIGHTER

## 1:48 SCALE PLASTIC KIT



eduard

### intro

The roots of the MiG-29 can be traced back to the end of the sixties and beginning of the seventies. At that time, information had leaked out that the United States was working on the F-X program, from which emerged the F-15 Eagle. The Soviet Union, obviously, could not be left behind in the arms race, and the General Staff formulated requirements for the Perspektivniy frontovoy istrebitel (PFI - Advanced Frontal Fighter Aircraft). It was to have the ability to take off from small, unprepared fields, have a useful combat radius, excellent turn around time and be able to carry a varied payload. The speed of the machine was to be in excess of Mach 2.

Aerodynamic study was passed to TSAGI in co-operation with OKB Sukhoi. It became clear that the best route to take would include two roads. As a result, the PFI program was expanded to also include the PLFI (Advanced Light Frontal Fighter Aircraft), which was to result in the Soviet answer to the F-16 Fighting Falcon lightweight fighter. The plans assumed that the Soviet air force would be composed of one-third PFI aircraft, and two-thirds PLFI, and as such would find its adversary to be mainly the F-16 and the YF-17 (which evolved into the F/A-18). The PFI program with Sukhoi led to the Su-27. The PLFI was entrusted to the Mikoyan bureau. Work on the latter type, under the factory designation 'Izdelye' 9 began in 1974, and three years later, on October 6, 1977, the aircraft first took to the air. The program suffered setbacks thanks to the loss of two prototypes, due to problems traced back to the engines. In 1984, air force tests were concluded, and thanks to positive results, the first production machines began to reach Soviet frontal fighter units. These new aircraft began to replace the MiG-23. In keeping with the requirements, the aircraft could lift off from unprepared strips. Auxiliary air intakes on top of the blended fuselage/wing structure provided air on the ground, allowing the regular intakes to close and prevent FOD. The existence of the new fighter was discovered by NATO very early after the program began, and the ASCC allocated the name Fulcrum 'A'. Besides the base version of the MiG-29 (Izdelye 9-12), there was also the MiG-29B, an export version intended for countries outside of the Warsaw Pact. Training was carried out on a two-seat version, the MiG-29UB (Izdelye 9-51), which carried the NATO codename Fulcrum 'B'.

Further development and production was impacted by the fall of the communist block, and the inevitable economic collapse of the Soviet Union and its consequent splitting up of state assets with varying degrees of dependence on Russia.

Production also came for the MiG-29K and MiG-29SMT (both coded Fulcrum 'D'). The MiG-29K is a navalized variant and besides with the country of origin, it also flies with the Indian Navy. The intended role is that of carrier fighter for the 'Vikramaditya' (formerly the Soviet carrier 'Admiral Gorshkov'). The SMT is a modernized variant of the MiG-29.

### úvodem

Kořeny vzniku MiGu-29 sahají až do přelomu 60. a 70. let minulého století. Tehdy vešlo ve známost, že americké ozbrojené síly pracují na programu F-X, jehož výsledkem se stal typ F-15 Eagle. Sovětský svaz pochopitelně ve zbrojních závodech nemohl zůstat pozadu. Generální štáb zformuloval požadavky na Perspektivnyj frontovoj istrebitel (PFI - pokročilý frontový stíhací letoun). Měl mít schopnost operovat z malých, nezapravených ploch, disponovat značným doletem, vynikající obratností a nést rozsáhlou výzbroj. Požadována také byla rychlost stroje vyšší než 2 machy.

Práci na aerodynamické studii se zhostil CAGI ve spolupráci s konstrukční kanceláří Suchoj. Záhy se však ukázalo, že bude potřeba jít dvěma cestami. K programu PFI tak přibyl ještě program PLFI (pokročilý lehký frontový stíhací letoun), který měl sovětskému letectvu dát ekvivalent lehkého stíhacího stroje F-16 Fighting Falcon. Plány předpokládaly, že sovětské letectvo by se mělo skládat z jedné třetiny z letounů PFI a ze dvou třetiny ze strojů PLFI a mít tak protivníky letounů F-16 a YF-17 (později F/A-18). Programu PFI se s definitivní platností ujal Suchoj a výsledkem se stal typ Su-27. Program PLFI dostala na starost konstrukční kancelář Mikojan.

Práce na letounu pod továrním označením Izdělje 9 začaly v roce 1974 a o tři roky později, 6. října 1977, se letoun dostal poprvé do vzduchu. Program se dostal do skluzu díky haváriím dvou prototypů, příčinou byly problémy s motory. V roce 1984 byly dokončeny testy prováděné letectvem a na základě jejich kladného závěru začaly v témže roce dodávky sériových letounů k prvním jednotkám sovětského frontového letectva. Zde nové stroje začaly nahrazovat MiGu-23. V souladu se zadáním mohly operovat také z nezapravených ploch. Nasátí nečistot do motorů zabraňovaly alternativní vstupy vzduchu na horní ploše křídla, tzv. žábry.

Existenci nového stíhacího letounu rozvědka NATO zjistila velmi brzy po jeho vzniku. Kódové označení znělo „Fulcrum A“.

Kromě základní verze MiG-29 (Izdělje 9-12) vznikla také hůře vybavená verze MiG-29B, která byla exportována do zemí, které nebyly členy Varšavské smlouvy. Pro výcvik slouží dvoumístná varianta MiG-29UB (Izdělje 9-51), kterou NATO nazývala „Fulcrum B“.

Další vývoj a výrobu letounu poznamenal rozpad komunistického bloku a s ním spojený ekonomický kolaps Sovětského svazu a jeho následné štěpení na státní útvary s různou úrovní nezávislosti na Rusku.

Výroby se dočkaly ještě verze MiG-29K a MiG-29SMT (obě značené „Fulcrum D“). Verze SMT představuje modernizovanou podobu devěťadvacítek. MiG-29K je novalizovaná varianta devěťadvacítky a kromě země svého původu létá také v indických službách. Zamýšlena je služba na letadlové lodi Vikramadityja (původně sovětské plavidlo Admirál Gorškov).

## E MiG-29B, Iranian Air Force, 11<sup>th</sup> Squadron, Teheran-Mehrabad, Iran, 1990s.

This aircraft was part of the first delivery batch of MiG-29s to Iran in 1990. The actual factory type was the 'Izdelye 9-12B', which was an electronically downgraded export version below the standard of that which was delivered to the Warsaw Pact. The Islamic Republic of Iran Air Force took delivery of 24 MiG-29s between 1990 and 1991, including four 'UB' two-seaters. Another four arrived from Iraq during the first Gulf War. Currently, Iran has two bases operating MiG-29s. The 11<sup>th</sup> Squadron is based at Mehrabad, and Tabriz is home to the 23<sup>rd</sup> Squadron.

FOR COMPLETE PROFILE PLEASE REFER  
KOMPLETNÍ KAMUFLÁŽNÍ SCHÉMA  
NALEZNETE NA  
[www.eduard.com/info/photos/1157](http://www.eduard.com/info/photos/1157)

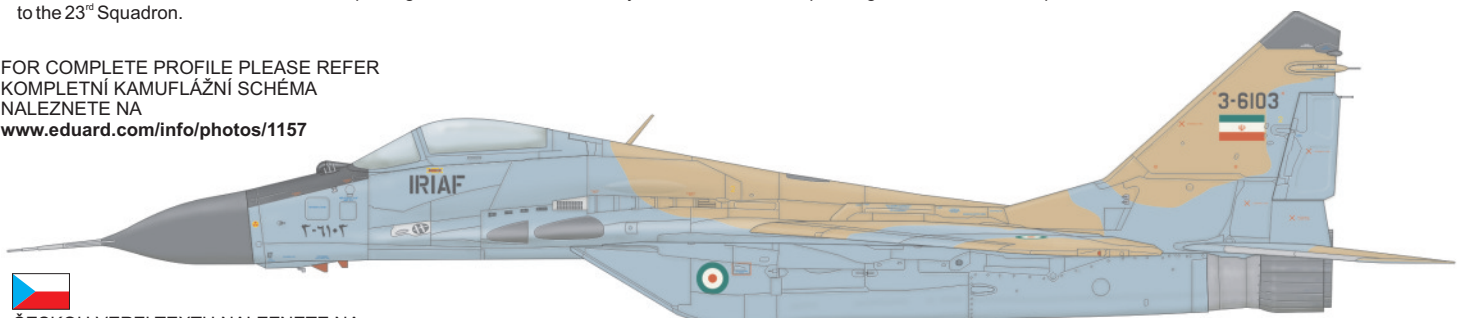

ČESKOU VERZI TEXTU NALEZNETE NA  
[www.eduard.com/info/photos/1157](http://www.eduard.com/info/photos/1157)



Carefully read instruction sheet before assembling. When you use glue or paint, do not use near open flame and use in well ventilated room. Keep out of reach of small children. Children must not be allowed to suck any part, or pull vinyl bag over the head.



Před započetím stavby si pečlivě prostudujte stavební návod. Při používání barev a lepidel pracujte v dobře větrané místnosti. Lepidla ani barvy nepoužívejte v blízkosti otevřeného ohně. Model není určen malým dětem, mohlo by dojít k požití drobných dílů.



lire soigneusement la fiche d'instructions avant d'assembler. Ne pas utiliser de colle ou de peinture à proximité d'une flamme nue, et aérer la pièce de temps en temps. Garder hors de portée des enfants en bas âge. Ne pas laisser les enfants mettre en bouche ou sucer les pièces, ou passer un sachet vinyl sur la tête.



Von dem Zusammensetzen die Bauanleitung gut durchlesen. Kleber und Farbe nicht nahe von offenem Feuer verwenden und das Fenster von Zeit zu Zeit Belüftung öffnen. Bausatz von kleinen Kindern fernhalten. Verhüten Sie, daß Kinder irgenwelche Bauteile in den Mund nehmen oder Plastiktüten über den Kopf ziehen.



組み立てる前に必ず説明書をお読み下さい。接着剤や塗料をご使用の際は、窓を開けて十分な換気をおこない、火のそばでは使用しないで下さい。小さな子供の手の届かない所に必ず保管して下さい。部品や破片を噛んだり、なめたり、飲んだりすると大変危険です。又、部品を取り出した後のビニール袋は、小さな子供が頭から被ったりすると窒息する恐れがありますので、破り捨てて下さい。

## INSTRUCTION SIGNS



## INSTR. SYMBOL



## INSTRUKTION SINNBILDEN



## SYMBOLES



## 記号の説明



OPTIONAL  
VOLBA  
FACULTATIF  
NACH BELIEBEN  
選択する



BEND  
OHNOU  
PLIER SIL VOUS PLAIT  
BITTE BIEGEN  
折る



OPEN HOLE  
VYVRTAT OTVOR  
FAIRE UN TROU  
OFFNEN  
穴を開ける



SYMETRICAL ASSEMBLY  
SYMETRICKÁ MONTÁŽ  
MONTAGE SYMÉTRIQUE  
SYMMETRISCHE AUFBAU  
左右均等に組み立てる



NOTCH  
ZÁŘEZ  
L INCISION  
DER EINSCHNITT  
切る



REMOVE  
ODŘÍZNOU  
RETIRER  
ENTFERNEN  
移す



APPLY EDUARD MASK  
AND PAINT  
POUŽIT EDUARD MASK  
NABARVIT

## PARTS



## DÍLY



## TEILE



## PIÈCES



## 部品

A&gt;

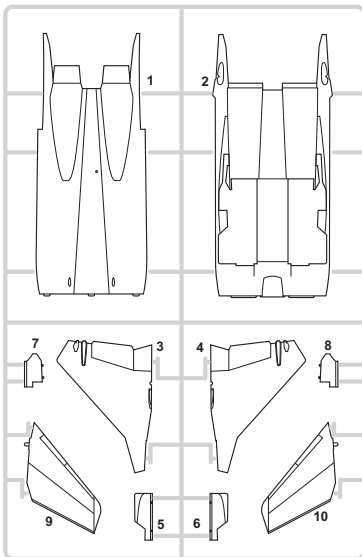

B&gt;

## PLASTIC PARTS

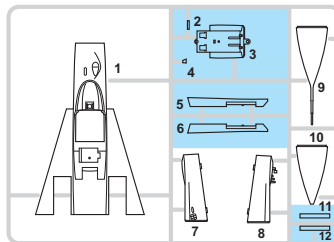

C&gt;

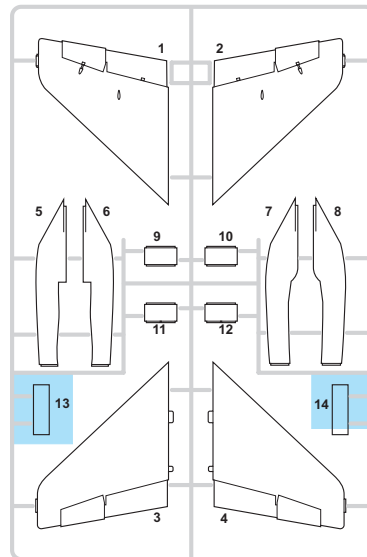

D&gt;

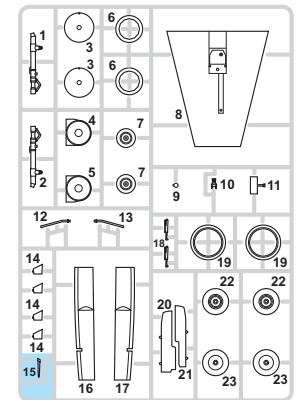

E&gt;

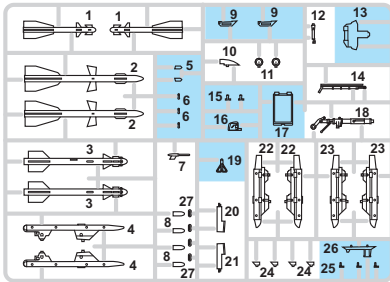

F&gt;

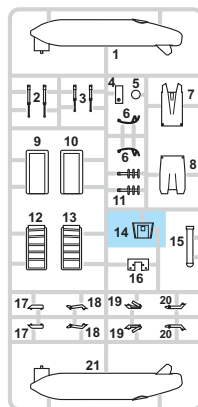

G&gt;

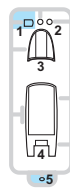
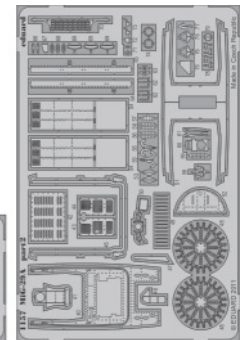
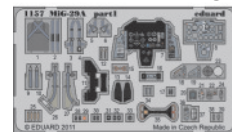
PE - PHOTO ETCHED  
DETAIL PARTS

## R - RESIN PARTS

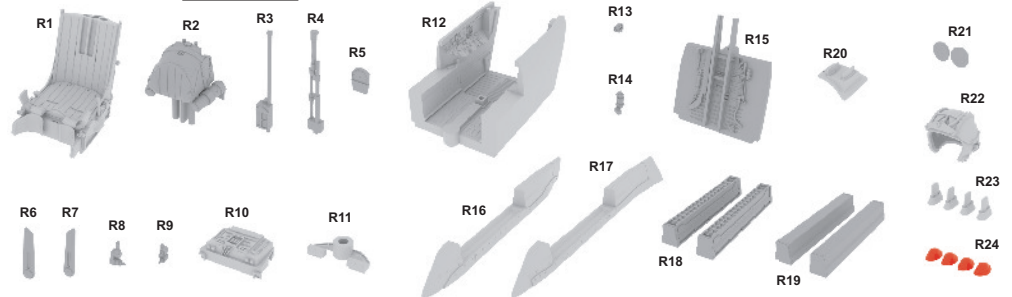

-Parts not for use. -Teile werden nicht verwendet. -Pièces à ne pas utiliser. -Tyto díly nepoužívejte při stavbě. - 使用しない部品

eduard  
MASK

FILM



## COLOURS



## BARVY



## FARBEN



## PEINTURE



## 色

| GSI Creos (GUNZE) |          |              |
|-------------------|----------|--------------|
| AQUEOUS           | Mr.COLOR |              |
| [H7]              | [C7]     | BROWN        |
| [H11]             | [C62]    | FLAT WHITE   |
| [H12]             | [C33]    | FLAT BLACK   |
| [H17]             |          | COCOA BROWN  |
| [H22]             |          | GRAY         |
| [H27]             | [C19]    | TAN          |
| [H44]             |          | FLESH        |
| [H47]             | [C41]    | RED BROWN    |
| [H51]             | [C11]    | LIGHT GRAY   |
| [H53]             | [C13]    | NEUTRAL GRAY |

| GSI Creos (GUNZE) |        |               |
|-------------------|--------|---------------|
| [H77]             | [C137] | TIRE BLACK    |
| [H90]             | [C47]  | CLEAR RED     |
| [H122]            | [C122] | LIGHT GREEN   |
| [H136]            | [C136] | RUSSIAN GREEN |
| [H305]            | [C305] | GRAY          |
| [H308]            | [C308] | GRAY          |
| [H309]            | [C309] | GREEN         |
| [H319]            | [C319] | LIGHT GREEN   |
| [H320]            | [C320] | DARK GREEN    |
| [H324]            | [C324] | LIGHT GRAY    |

| GSI Creos (GUNZE)       |        |               |
|-------------------------|--------|---------------|
| [H325]                  | [C325] | GRAY          |
| [H334]                  | [C334] | BARLEY GRAY   |
| [H337]                  | [C337] | GRAYISH BLUE  |
| Mr.COLOR SUPER METALLIC |        |               |
| [SM06]                  |        | CHROME SILVER |
| Mr.METAL COLOR          |        |               |
| [MC213]                 |        | STEEL         |
| [MC214]                 |        | DARK IRON     |
| [MC218]                 |        | ALUMINIUM     |

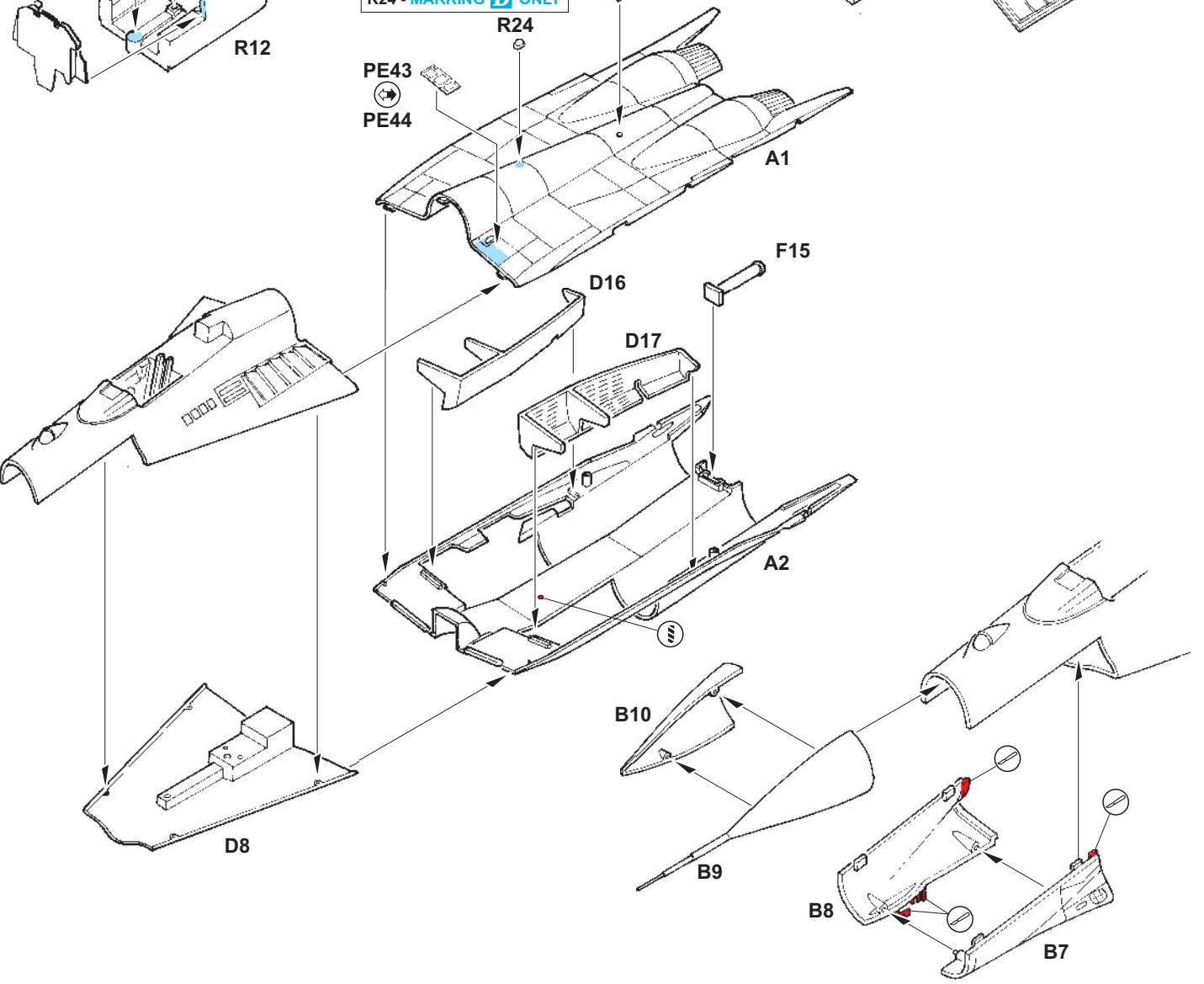
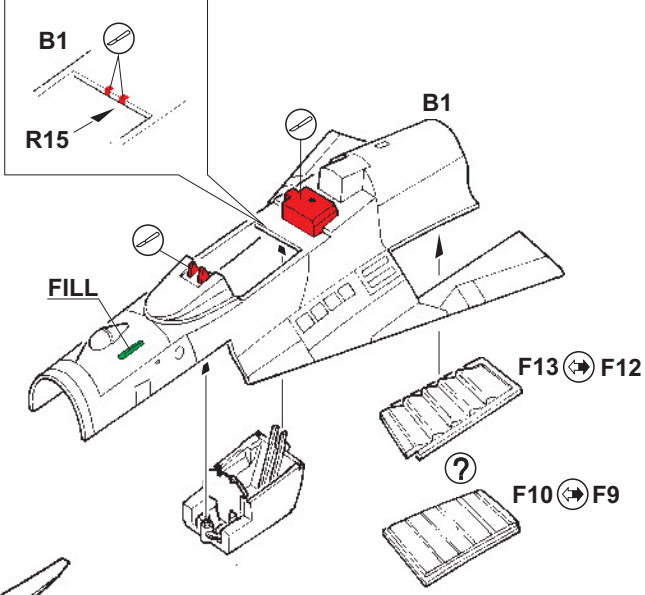
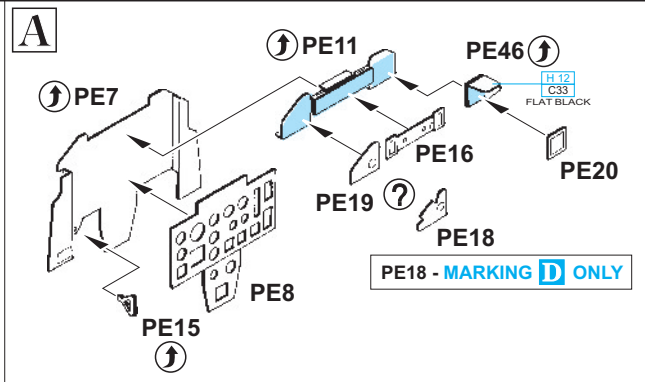
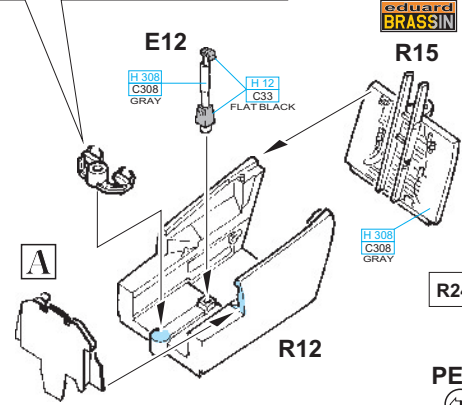
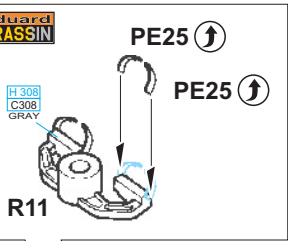
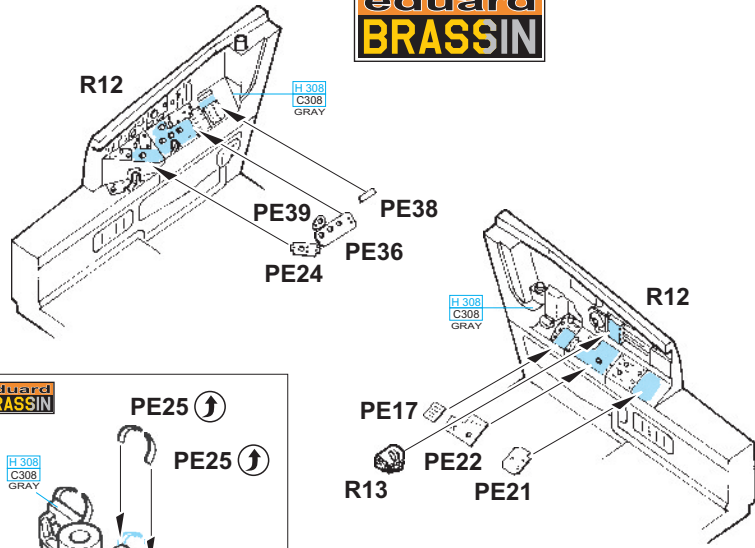

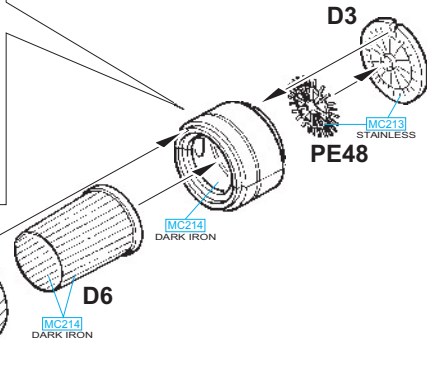
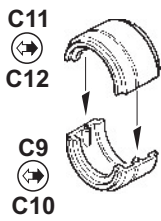
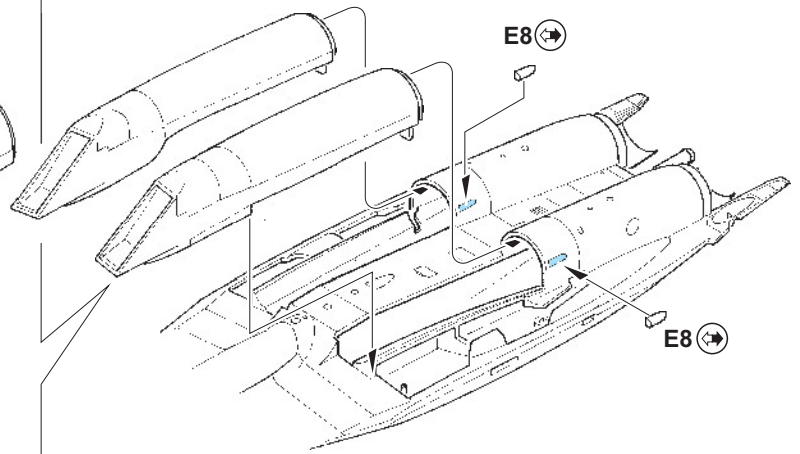
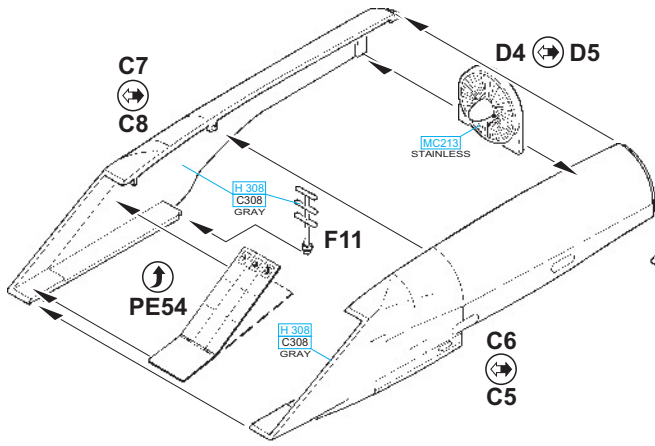

OPEN / OTEVŘENÝ

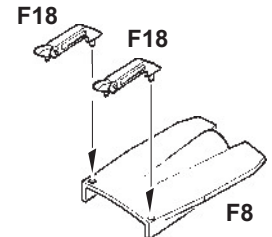
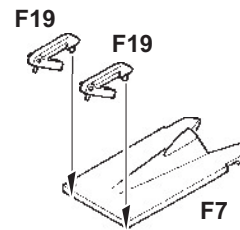

CLOSED / ZAVŘENÝ

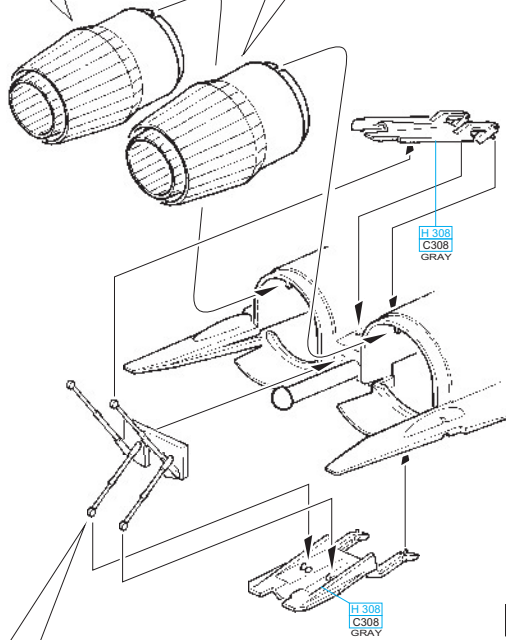
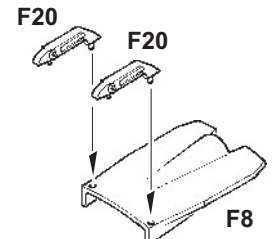
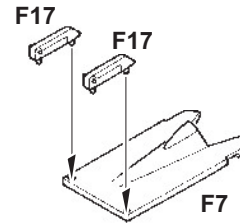

R24 - MARKING **D** ONLY



R24

PE42



R23

R23 - MARKING **D** ONLY

PE67

PE77

PE55

PE56

PE68

PE68

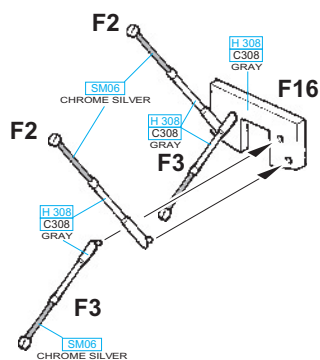

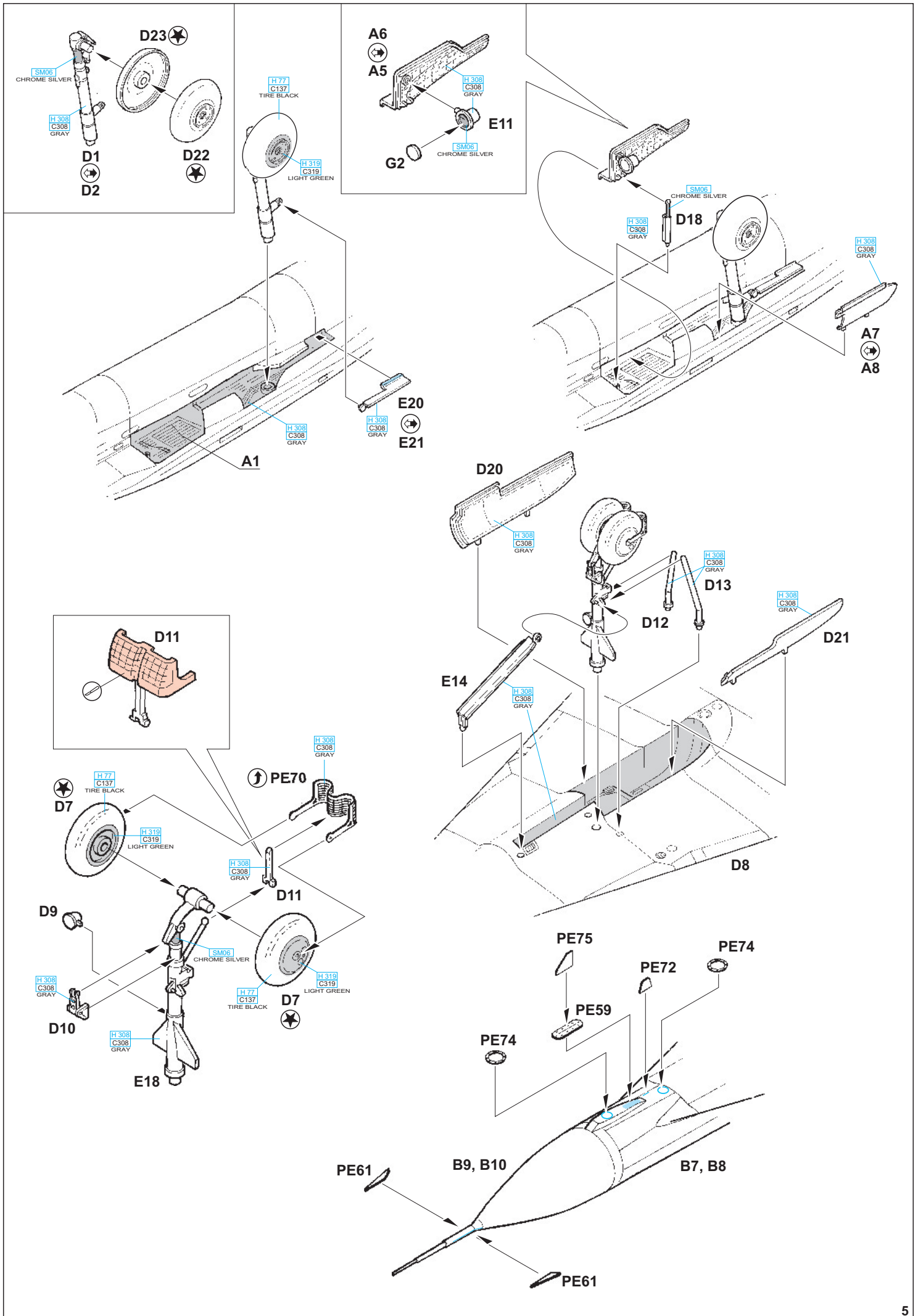

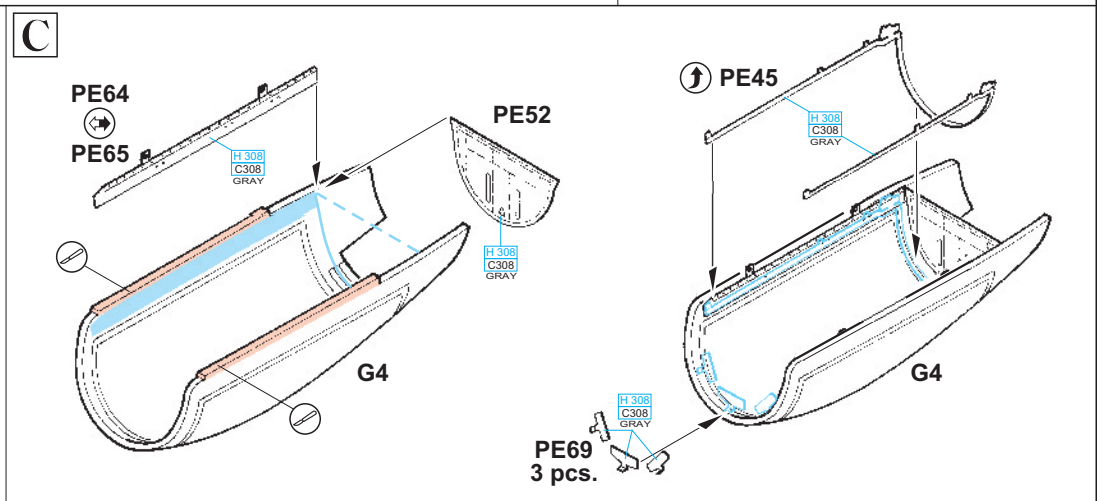
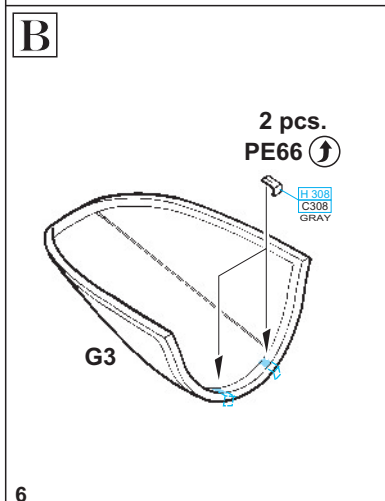
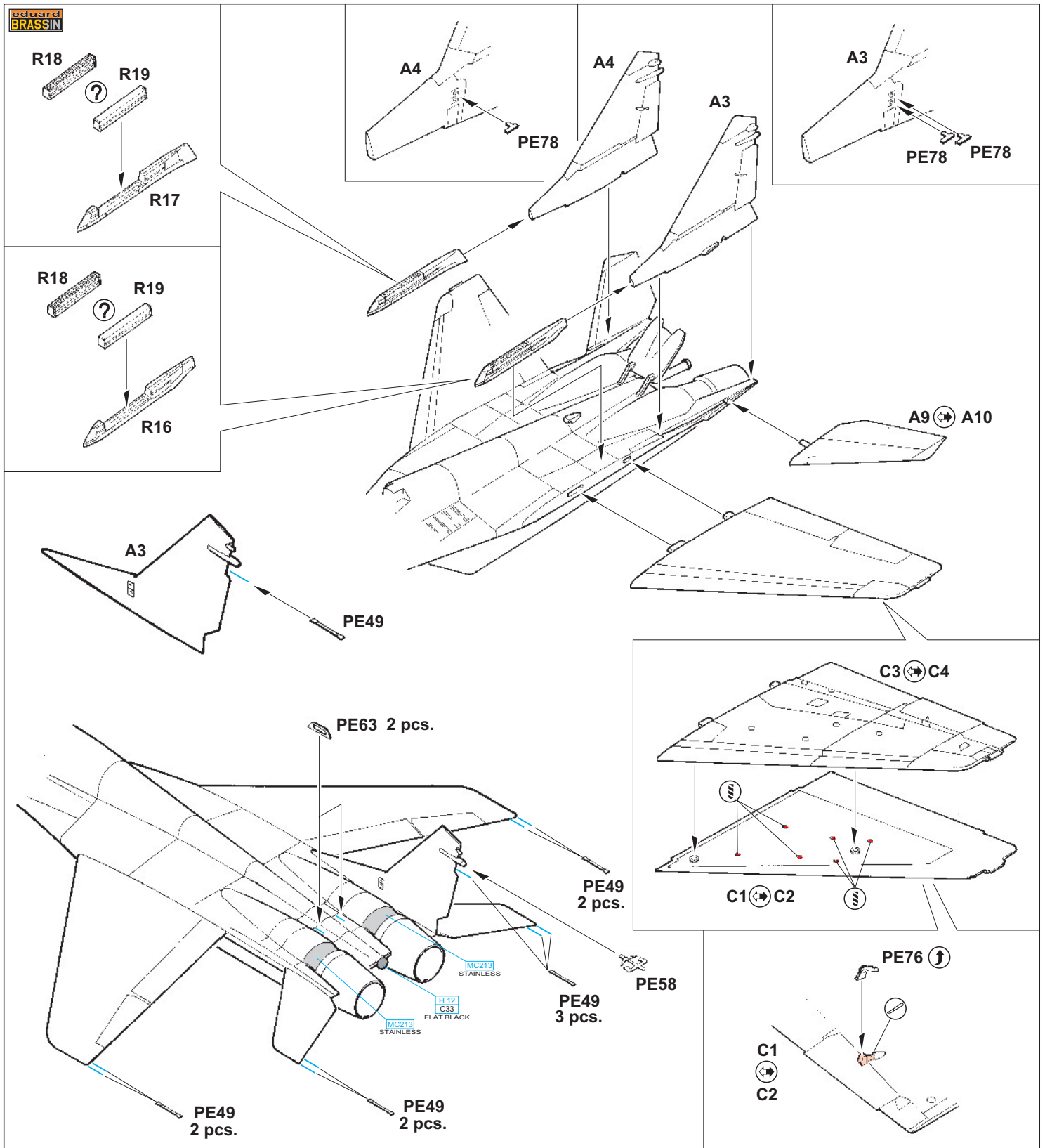

D

eduard  
BRASSIN

SEE YOUR REFERENCES  
POUŽIJTE  
SVÉ REFERENCE

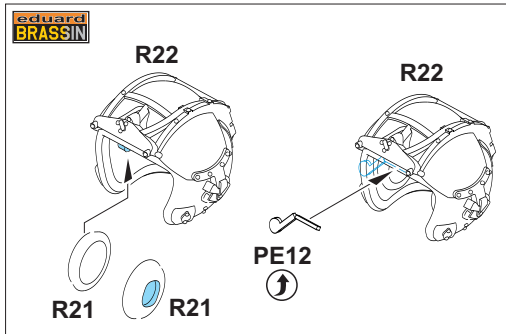
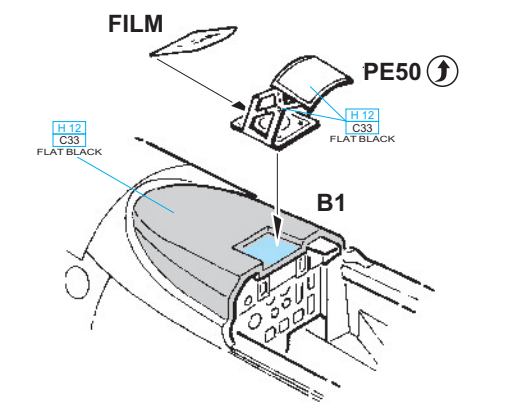
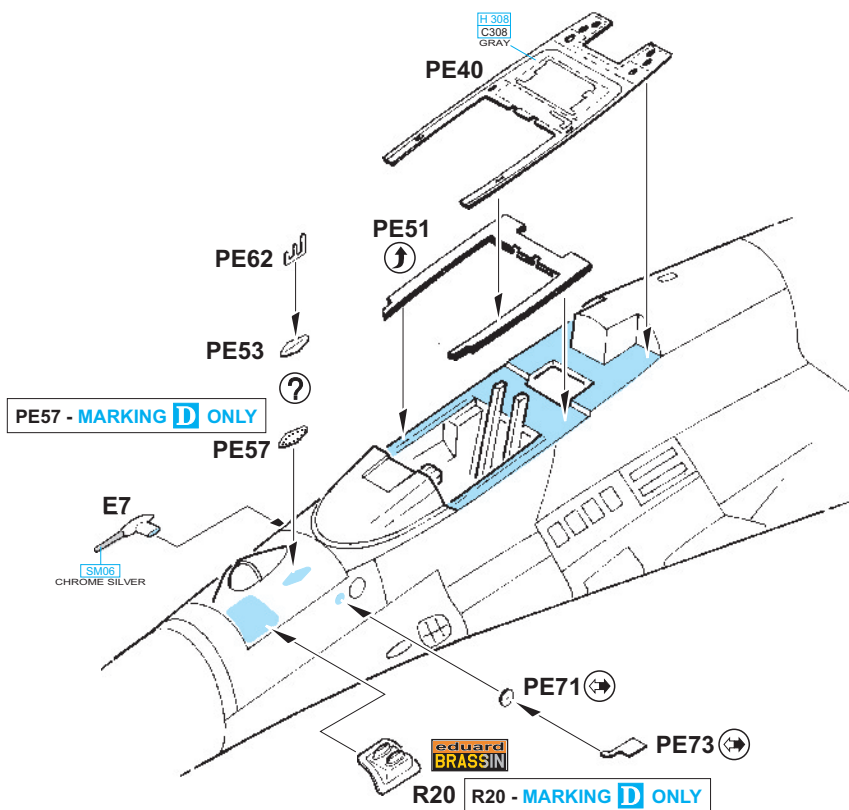
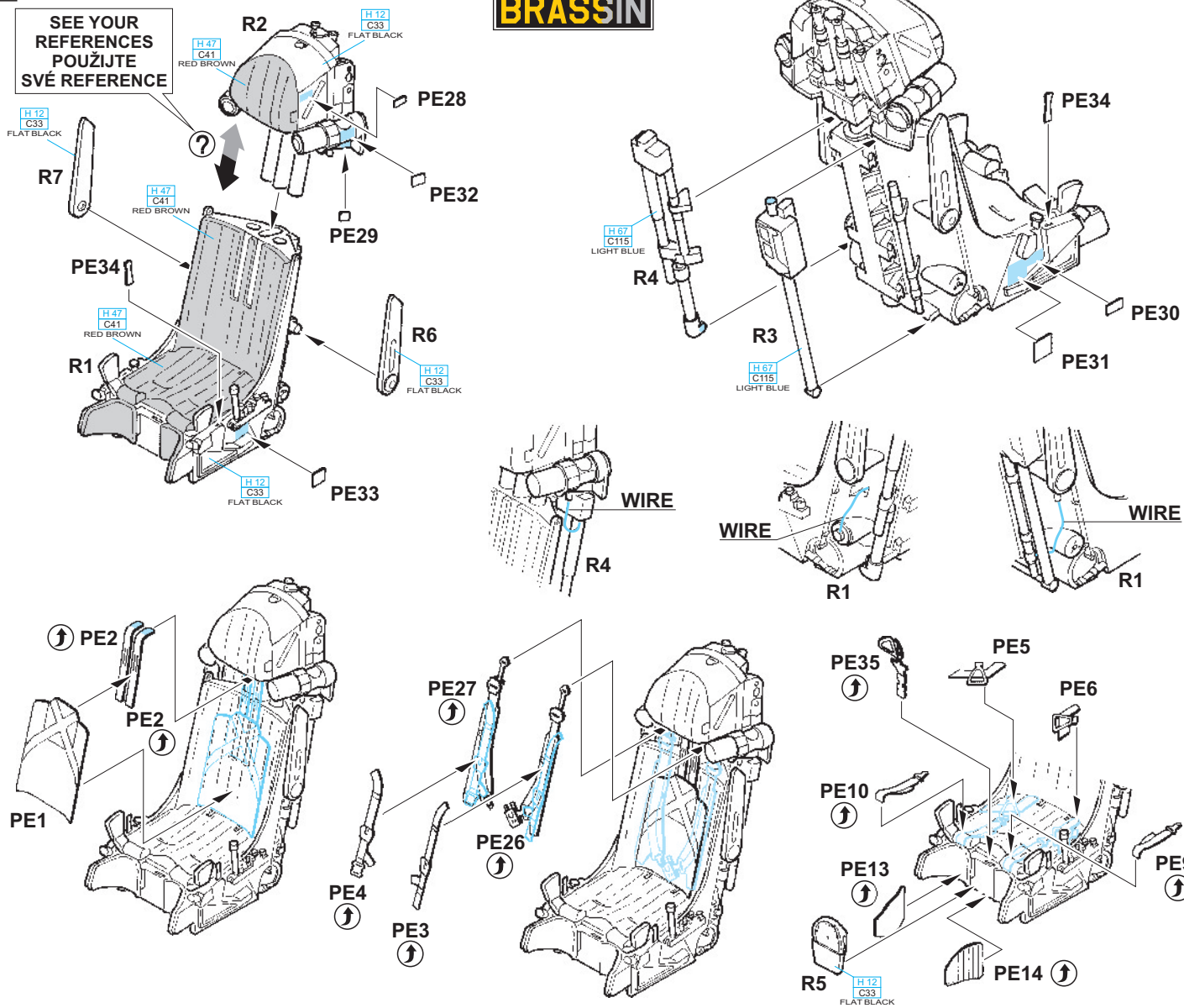

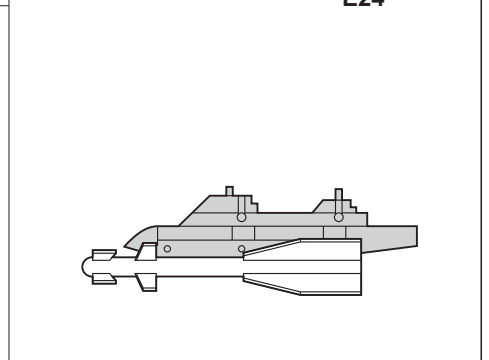
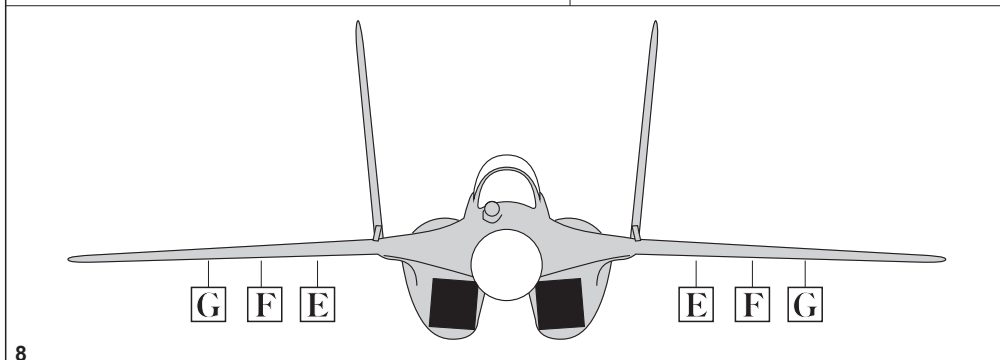
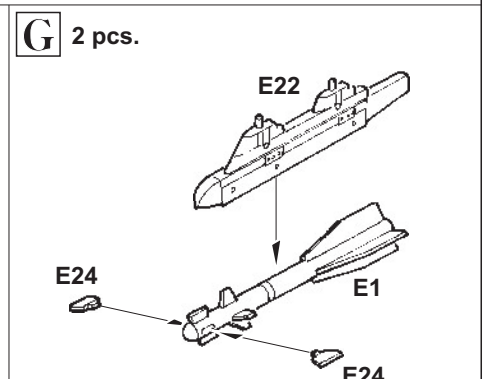
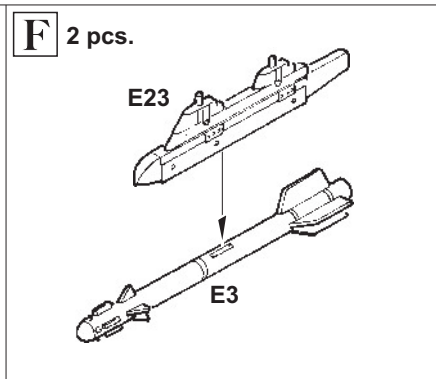
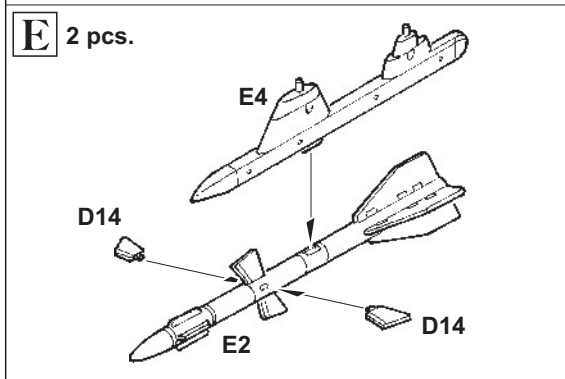
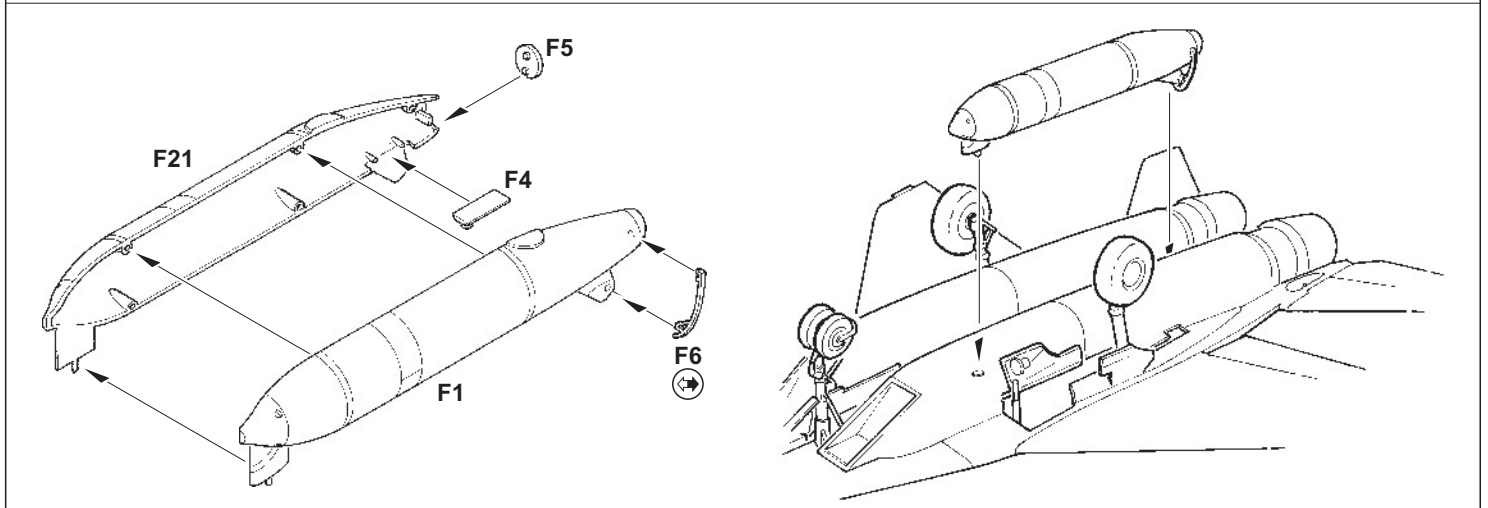
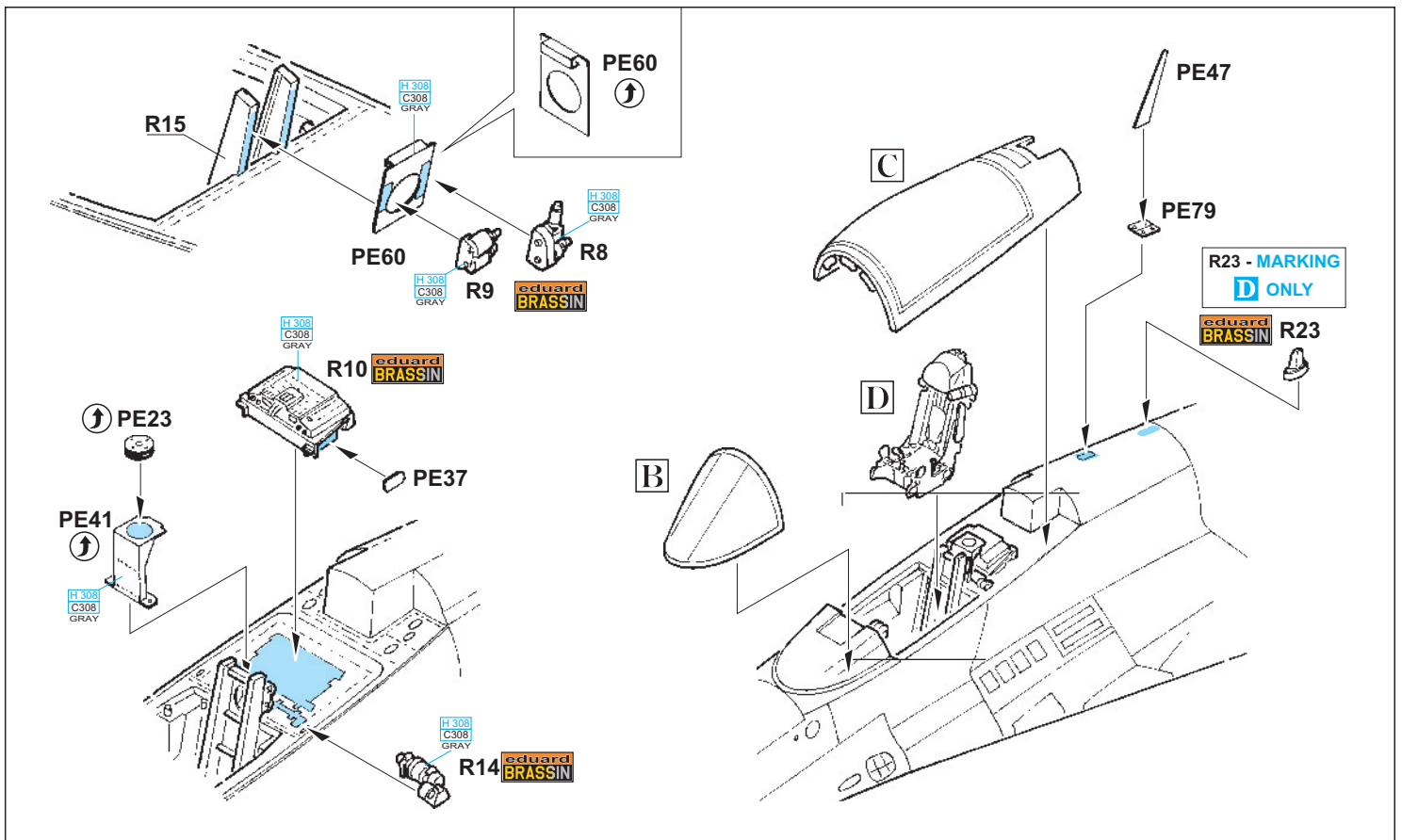







# C MiG-29A, Czech Republic Army Air Force, No.1 Sq., 11th Sqdn., Zatec Air Base, Czech Republic, 1993

The aircraft with the serial number 2960526377 was delivered from the Soviet Union to the 11<sup>th</sup> slp. (Fighter Air Regiment) in Zatec AB in late 80's. This was one of ten MiG-29As delivered that were capable of carrying the RN-40 nuclear weapon. This capability was removed from the aircraft to satisfy conditions imposed by international nuclear disarmament agreements. In all, Czechoslovakia took delivery of eighteen single seat and two two-seat MiG-29s from the Soviet Union. In October, 1993, the 11<sup>th</sup> slp MiG-29s were transferred to Ceske Budejovice to the 1<sup>st</sup> slp. Over the course of dividing up assets between the Czech Republic and Slovakia in 1993, this aircraft remained in the Czech Republic, and became a part of a controversial agreement that saw the Czech MiGs go to Poland for eleven W-3A Sokol utility helicopters. Today, this aircraft flies with the Polish air force with the bort number '77'.

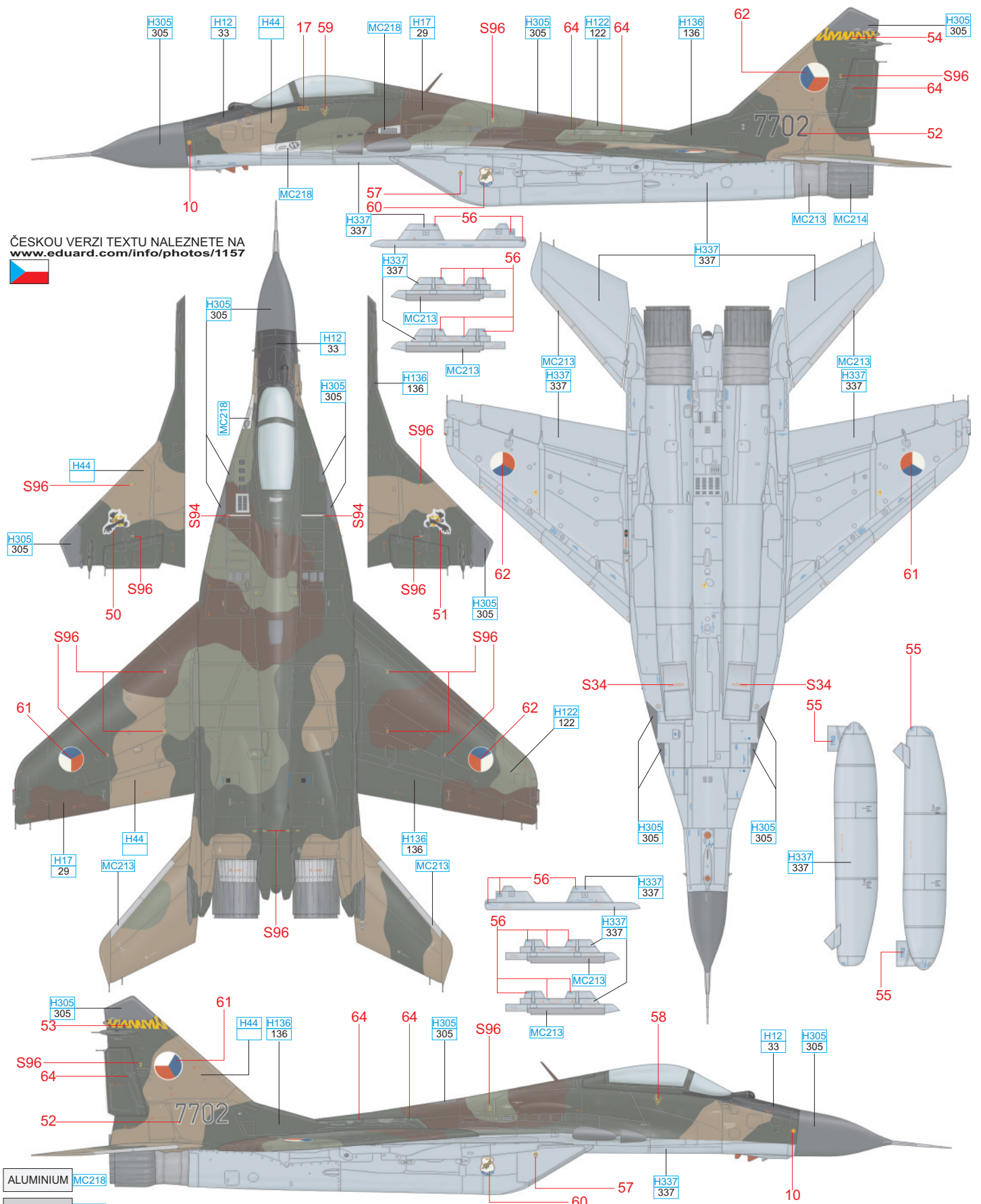

ČESKOU VERZI TEXTU NALEZNETE NA [www.eduard.com/info/photos/1157](http://www.eduard.com/info/photos/1157)



|           |       |          |          |          |     |          |          |          |          |          |        |          |          |       |        |
|-----------|-------|----------|----------|----------|-----|----------|----------|----------|----------|----------|--------|----------|----------|-------|--------|
| ALUMINIUM | MC218 | FS 26293 | H337 337 | FS 20227 | H44 | FS 24266 | H122 122 | FS 24079 | H136 136 | FS 20045 | H17 29 | FS 36118 | H305 305 | BLACK | H12 33 |
|-----------|-------|----------|----------|----------|-----|----------|----------|----------|----------|----------|--------|----------|----------|-------|--------|

# D MiG-29A, Lt.Col. Robert Cierniak, CO of No.1 Squadron of Tactical Air Force, Minsk Mazowiecki, Poland, 2005-2007

This MiG-29 was flown by Lt.Col. Robert 'Skuter' Cierniak, who served as CO of No. 1 'Warszawa' Squadron of Tactical Air Force from December 22, 2005 to October 30, 2007. The four-leaf clover, painted on both sides of the front of the aircraft, was a personal emblem. This aircraft also took part in the Polish military contingent 'Orlik', which operated in 2006 from the Lithuanian base at Zoknia. The purpose was to patrol the airspace over the Baltic states, Lithuania, Latvia and Estonia. This role is represented by the emblem on the vertical tail surfaces. The marking on the left side of the fuselage below the cockpit is that of the 7<sup>th</sup> Squadron 'Tadeusz Kosciuszko', which was a unit fighting against Russian bolsheviks during the Soviet-Polish conflict in 1919-1920. The core of the unit was made up of American pilots. This aircraft was delivered in 1990. The camouflage scheme consisting of two shades of grey was applied during modernization in Poland in the first decade on the twenty first century.

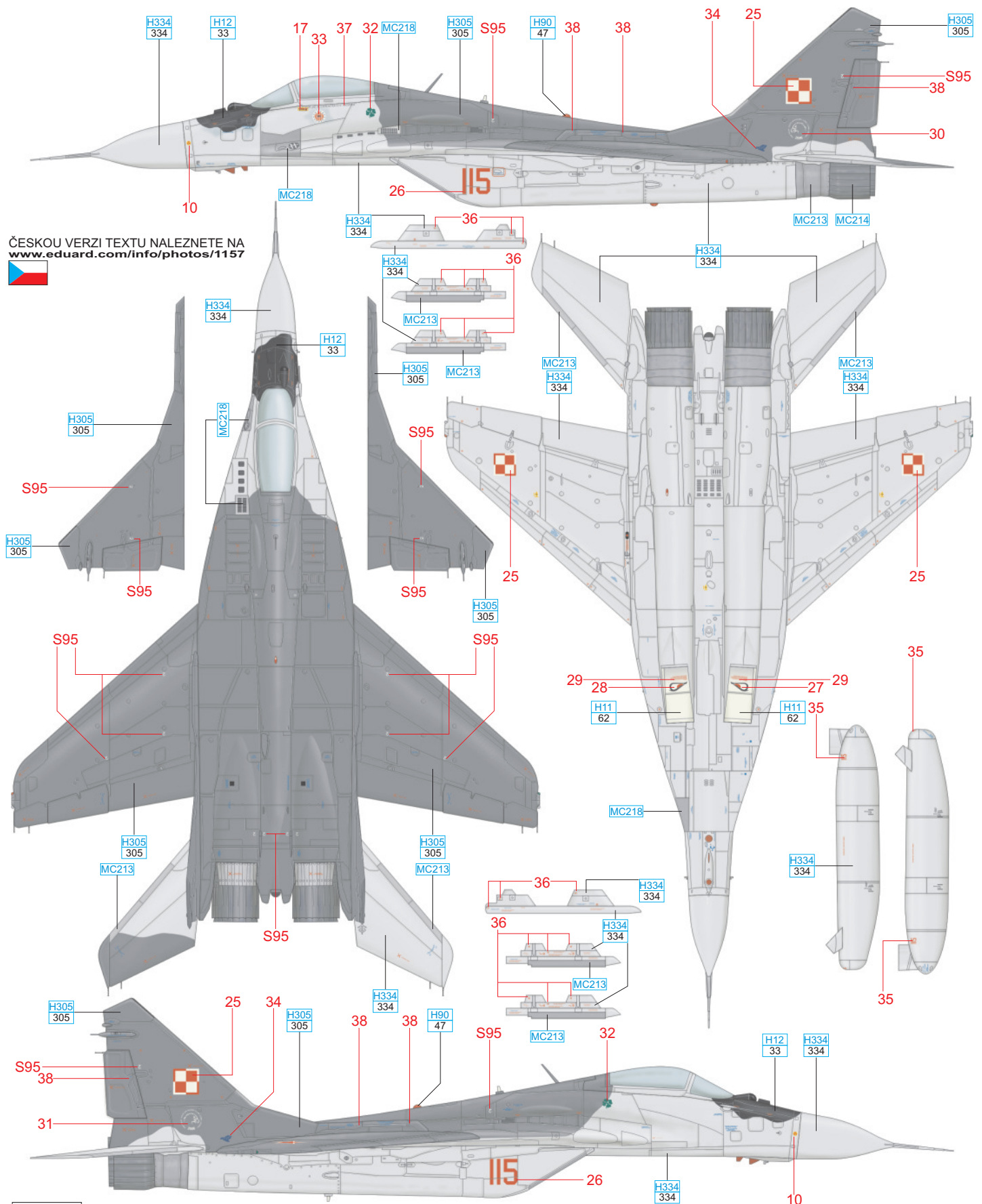

ČESKOU VERZI TEXTU NALEZNETE NA [www.eduard.com/info/photos/1157](http://www.eduard.com/info/photos/1157)



|           |       |       |       |           |       |       |        |            |          |          |          |       |        |           |        |
|-----------|-------|-------|-------|-----------|-------|-------|--------|------------|----------|----------|----------|-------|--------|-----------|--------|
| ALUMINIUM | MC218 | STEEL | MC213 | DARK IRON | MC214 | WHITE | H11 62 | LIGHT GREY | H334 334 | FS 36118 | H305 305 | BLACK | H12 33 | CLEAR RED | H90 47 |
|-----------|-------|-------|-------|-----------|-------|-------|--------|------------|----------|----------|----------|-------|--------|-----------|--------|



# E MiG-29B, Iranian Air Force, 11<sup>th</sup> Squadron, Teheran-Mehrabad, Iran, 1990s.

This aircraft was part of the first delivery batch of MiG-29s to Iran in 1990. The actual factory type was the 'Izdelye 9-12B', which was an electronically downgraded export version below the standard of that which was delivered to the Warsaw Pact. The Islamic Republic of Iran Air Force took delivery of 24 MiG-29s between 1990 and 1991, including four 'UB' two-seaters. Another four arrived from Iraq during the first Gulf War. Currently, Iran has two bases operating MiG-29s. The 11<sup>th</sup> Squadron is based at Mehrabad, and Tabriz is home to the 23<sup>rd</sup> Squadron.

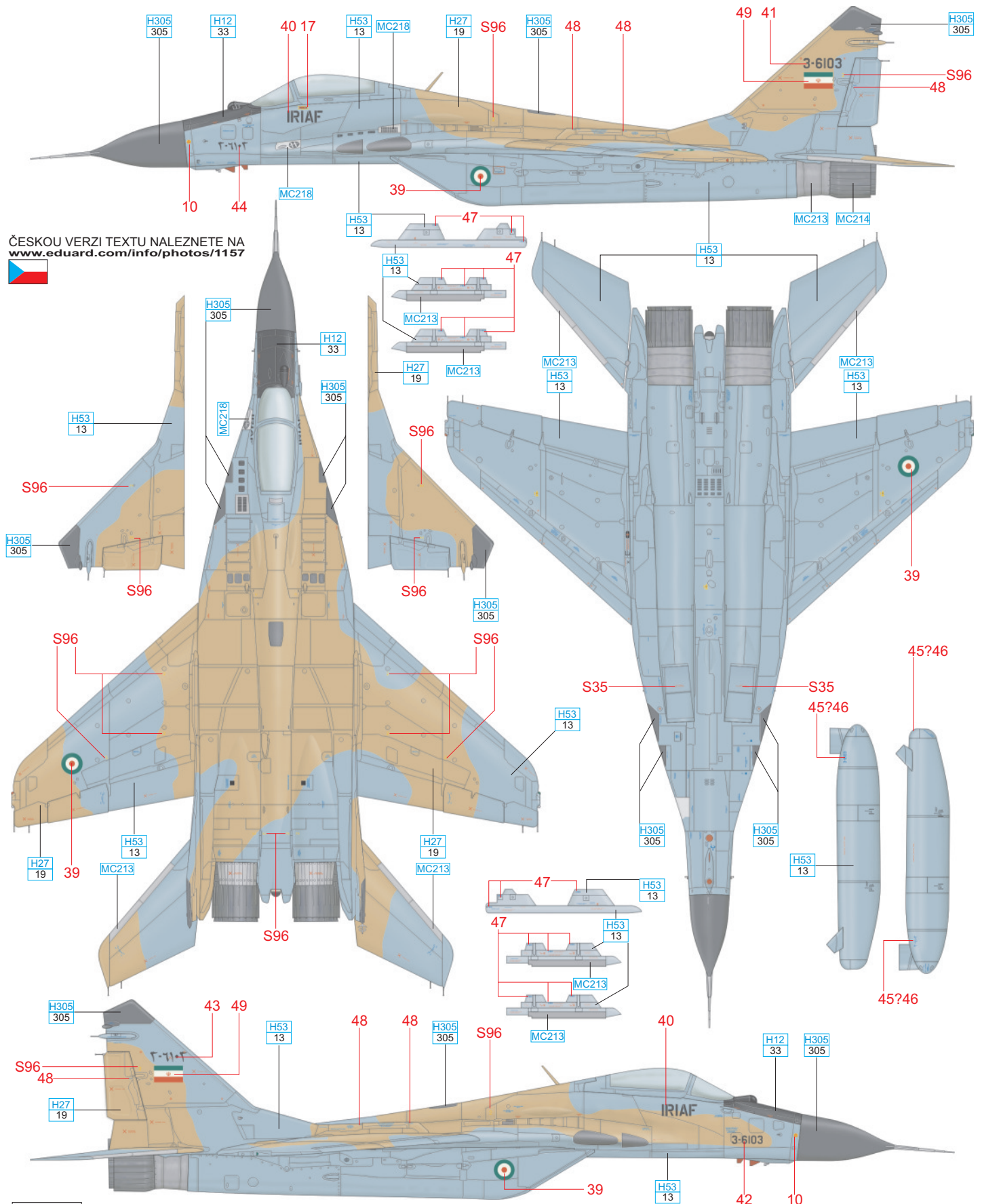

|           |       |           |       |          |           |          |             |
|-----------|-------|-----------|-------|----------|-----------|----------|-------------|
| ALUMINIUM | MC218 |           |       |          |           |          |             |
| STEEL     | MC213 | DARK IRON | MC214 | BLUEGREY | H53<br>13 | TAN      | H27<br>19   |
|           |       |           |       |          |           | FS 36118 | H305<br>305 |
|           |       |           |       |          |           | BLACK    | H12<br>33   |

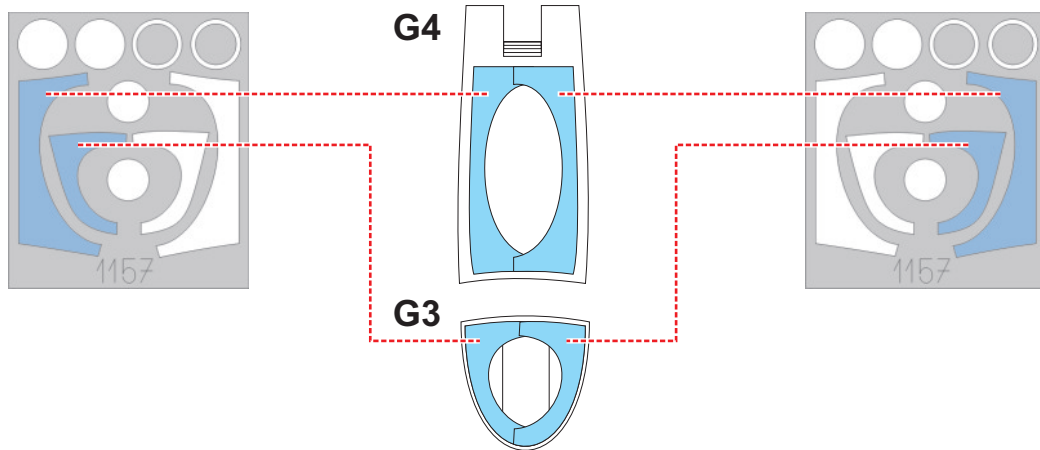
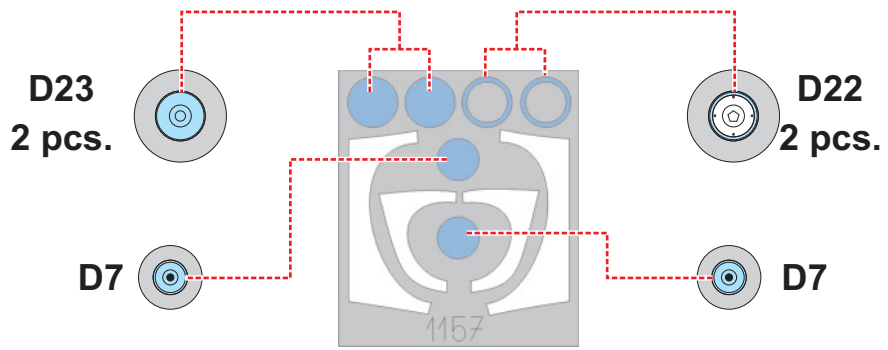
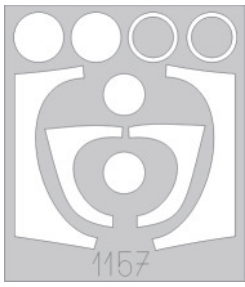

MiG-29A

STENCIL VARIANTS

SN-SERIAL NUMBER

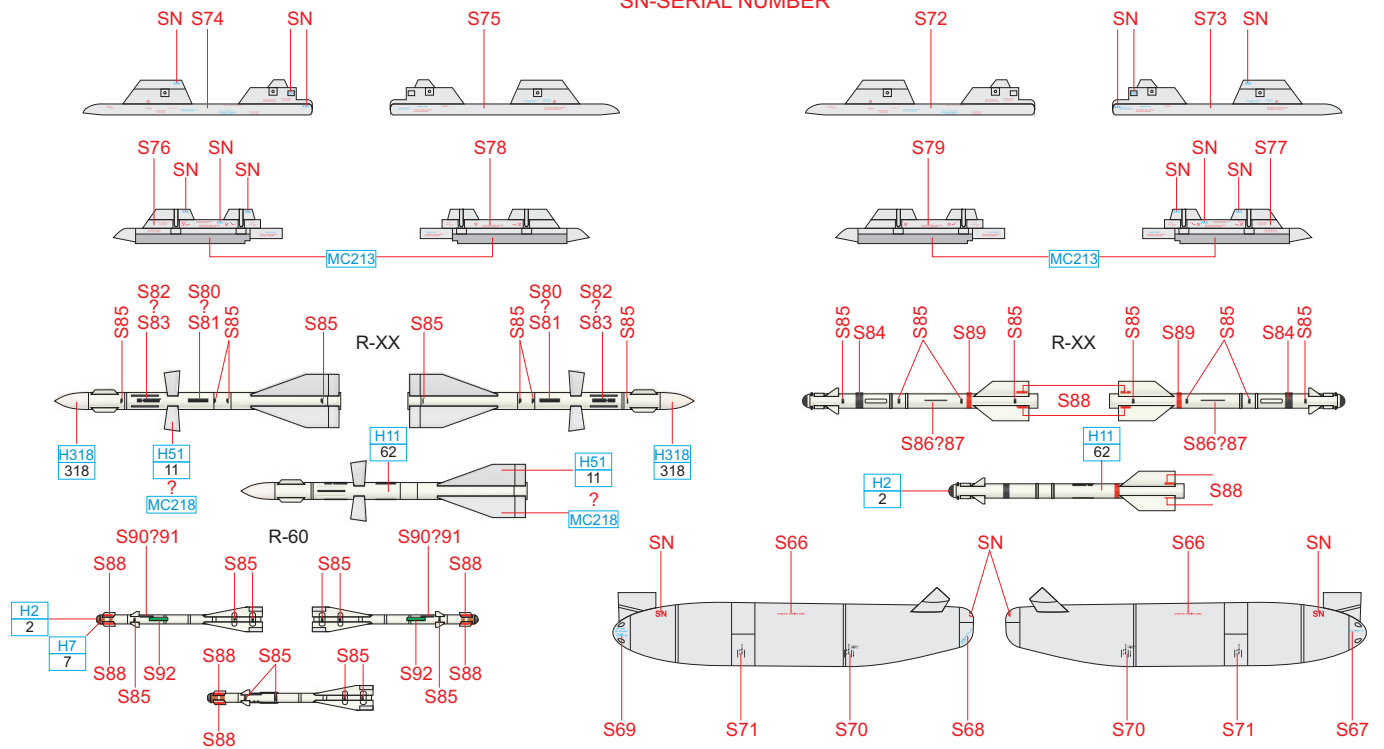

ALUMINIUM MC218

STEEL MC213

WHITE H11 62

RADOME H318 318

LIGHT GREY H51 11

BROWN H7 7

BLACK H2 2

Pro letoun Czech AF 7702 použijte popisky označené příponou "b".  
 Use stencils marked by suffix "b" when building Czech AF aircraft No. 7702.

