

US WWII BOMBER 1:48 SCALE PLASTIC KIT



eduard

intro

In all likelihood, no aircraft had such an instrumental influence on the outcome of the war, particularly through the event of one specific battle, as the SBD Dauntless. Aptly dubbed 'Slow But Deadly', at the time of entering service, the Dauntless was quite a fast aircraft for a bomber and during the war it was occasionally used as a standby interceptor. Because of its agility, Dauntless pilots did not hesitate to enter combat even against the superb Japanese Zero fighter. During the two day Coral Sea battle, Dauntless pilots and gunners accounted for some 40 of the 91 downed Japanese aircraft. The crew comprised of John Leppla and John Liska, for example, destroyed seven planes in the two days. Nevertheless, the main role of Dauntless crews was the dive bombing of land and sea targets, in which they had proven to be irreplaceable.

The development of the Dauntless was bound to a 1934 US Navy specification for a new dive-bomber. Six manufacturers submitted proposals, with two, Great Lake and Curtiss, being rejected from the outset, as they entered with biplane configurations. Although the specification did not specifically demand monoplane construction, the admiralty recognized that the way to go was through monoplane designs and assessed only entries from Northrop, Brewster, Martin and Vought. Northrop entered with their XBT-1 design of then already successful designer Edward Heinemann, but the US Navy chose the Vought XSB2U, later known as the Vindicator, as the winner. However, aircraft from the first 54 pieces in the test series had problems with their negative adjustment of propeller blades, acting as dive brake. Because of that, Northrop also received an order for 54 aircraft. The first XBT-1 took off in July 1935. It had a Pratt & Whitney engine providing 825 hp (606 kW) with a maximum speed of 212 mph (341 km/h). Subsequently, the company received a list of 1,937 changes to implement, among them a change from a partially retractable undercarriage to a fully retractable system.

Implementing the changes led to the BT-2, but at the time Northrop was already purchased by Donald Douglas, who decided to make another change - replacing the engine with the more powerful Wright R-1820-G103 Cyclone rated at 1000 hp (746 kW) and with a new, three blade propeller. The aircraft received a very positive response from pilots, as it reached a maximum speed of 267 mph (429 km/h). It was also very easy to control. The plane got its official designation, SBD-1, where SBD stood for Scouting, Bombing and Douglas. The new plane carried one 1000 lb (454 kg) bomb under the fuselage and two 100 lb (45 kg) bombs under the wings. The armament consisted of two forward firing .50 caliber (12,7 mm) machine guns and one .30 caliber (7,62 mm) machine gun fired by the rear gunner. By installing an autopilot and providing self-sealing fuel tanks, the SBD-2 version emerged, and the type received the name Dauntless. The airplane was very popular with pilots thanks to very good manoeuvrability and the ability to withstand high g-loads of + 9 g and - 4 g. The highest speed in a dive was also interesting: 429 mph (690 km/h). The next version, the SBD-3, was the first true 'combat' Dauntless. The design was adjusted according to the initial experiences provided by the European war theatre. The gunner received two .30 caliber (7,62 mm) machine guns, the canopy was supplied with a bullet-proof windscreen and the crew received armour protection. The USAAF also evaluated the type, borrowing planes from the USMC. The first order was for 78 airplanes, followed by another for 960, all designated A-24-DE Banshee, being equivalent to the SBD-3.

The combat debut for the Dauntless occurred on December 7, 1942, the day the Japanese attacked Pearl Harbor. Eighteen planes of VS-6 from the USS Enterprise were attacked by Japanese fighters, and although seven of them were shot down or crash landed, two Dauntless crews achieved aerial victories over Japanese Zeros.

At the beginning of the war in Pacific, the Dauntless was already considered as only an interim solution prior to the introduction of the more powerful SB2C Helldiver. But the intended successor had so many glitches, that the Dauntless had to soldier on as the main dive-bomber of the US Navy and US Marine Corps. The Dauntless did very well in the battle of the Coral Sea, but the historical fight, in which the type won its main glory, was the Battle of Midway. Three squadrons from USS Enterprise and USS Yorktown led by W. C. McClusky (VS-6 and VB-6) and M. F. Leslie (VB-3) destroyed three Japanese aircraft carriers, Akagi, Kaga and Soryu within only six minutes. Later that day, aircraft from VS-6, led this time by E. Gallagher, heavily damaged the Hiryu. Subsequently, Dauntless crews managed to damage two Japanese cruisers, and one of them, the Mikuma, finally sank. The Japanese were unable to make good on such losses and the Pacific war started to turn in America's favour.

The Dauntless was proving itself to be a very effective weapon again and again. During 1943, their crews sunk not only six Japanese aircraft carriers, but also three cruisers, four destroyers and one battleship.

Because the SB2C still was not fully ready for service, the Dauntless underwent further development, leading to the SBD-4. It had an upgraded electrical system and a new propeller. Some 780 units were produced, and the army equivalent was the A-24A-DE, but the USAAF was not as successful with their Banshees as the Navy and Marines were with their Dauntlesses.

The most numerous version became the SBD-5, which was powered by the Wright R-1820-60 Cyclone providing 1200 hp (895 kW), allowing the SBD-5 to carry one 1600 lb (726 kg) bomb under the fuselage and two 324 lb (147 kg) bombs under the wings. Most of the planes also received anti vessel radar with an antenna under the leading edges of the wings. There were nearly three thousands SBD-5s produced.

The last version of the Dauntless was the SBD-6 with even more power and non-metal self-sealing fuel tanks. The US Navy first received them in February, 1944, and ordered 1450. But this number was later downgraded to only 450.

Apart from the US Navy and US Marine Corps, the Dauntless served briefly also with the Royal New Zealand Air Force, operating from Bougainville. The Free French army obtained 50 A-24B-DTs, using them mostly for training. The French Navy accepted 32 SBD-5s in November, 1944, and made good use of them supporting the allies on land. The sixth user of the Dauntless was Mexico, which obtained several A-24B-DTs at the beginning of 1944.

The US Navy retired its Dauntlesses shortly after the end of the war, while the USAF keeping them much longer as training and observation aircraft until 1959.



Carefully read instruction sheet before assembling. When you use glue or paint, do not use near open flame and use in well ventilated room. Keep out of reach of small children. Children must not be allowed to suck any part, or pull vinyl bag over the head.



Před započítím stavby si pečlivě prostudujte stavební návod. Při používání barev a lepidla pracujte v dobře větrané místnosti. Lepidla ani barvy nepoužívejte v blízkosti otevřeného ohně. Model není určen malým dětem, mohlo by dojít k požití drobných dílů.

INSTRUCTION SIGNS * INSTR. SYMBOLS * INSTRUKTION SINNBILDEN * SYMBOLES * 記号の説明



OPTIONAL
VOLBA



BEND
OHNOUT



OPEN HOLE
VYVRTAT OTVOR



SYMMETRICAL ASSEMBLY
SYMETRICKÁ MONTÁŽ



REMOVE
ODŘÍZNOUT



REVERSE SIDE
OTOČIT



APPLY EDUARD MASK
AND PAINT
POUŽÍT EDUARD MASK
NABARVIT

PARTS



DÍLY



TEILE



PIÈCES



部品

B>

3412-0600

PLASTIC PARTS

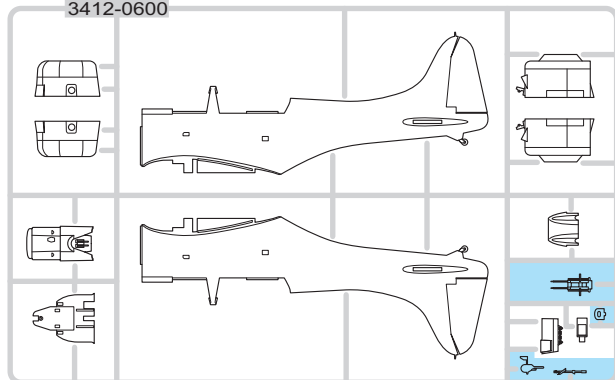

C>

3411-0700

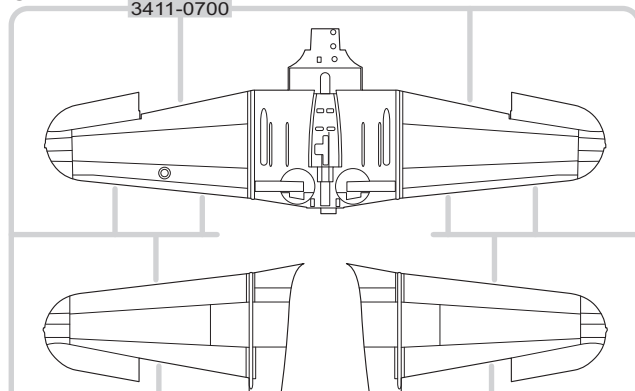

D>

3411-0800

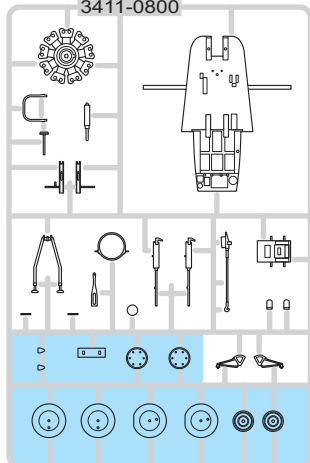

E>

3411-0811

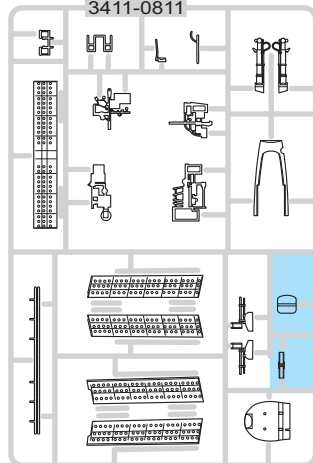

F>

3411-0901

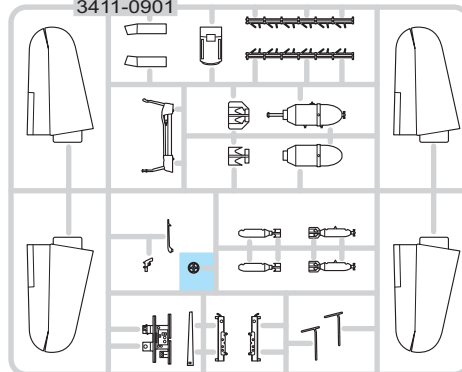

G>

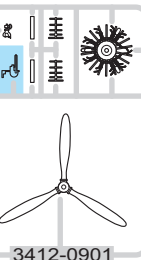

J>

3411-2001

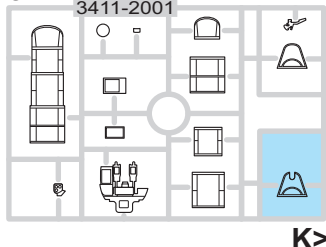

L>

K>

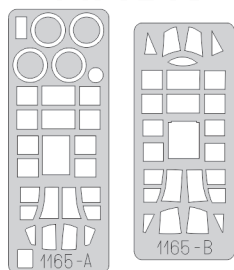
eduard
MASKeduard
BRASSIN

RP - RESIN PARTS

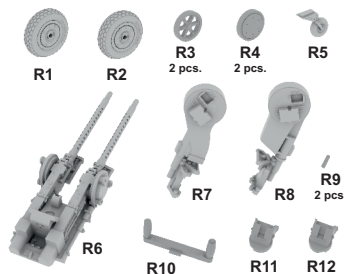

PE - PHOTO ETCHED DETAIL PARTS

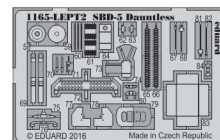
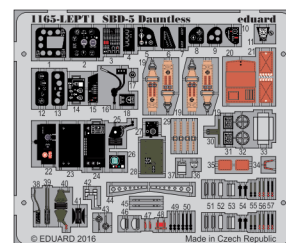

-Parts not for use. -Teile werden nicht verwendet. -Pièces à ne pas utiliser. -Tyto díly nepoužívejte při stavbě. - 使用しない部品

COLOURS



BARVY



FARBEN



PEINTURE



色

GSI Creos (GUNZE)		
AQUEOUS	Mr.COLOR	
H 4	C4	YELLOW
H 12	C33	FLAT BLACK
H 33	C81	RUSSET
H 36	C23	DARK GREEN
H 52	C12	OLIVE DRAB
H 53	C13	NEUTRAL GRAY
H 58	C27	INTERIOR GREEN
H 77	C137	TIRE BLACK
H 90	C47	CLEAR RED
H 94	C138	CLEAR GREEN
H 304	C304	OLIVE DRAB

AQUEOUS	Mr.COLOR	
H 316	C316	WHITE
H 317	C317	GRAY
H 327	C327	RED
H 365		GLOSS SEE BLUE
H 366		INTERMEDIATE BLUE
Mr.METAL COLOR		
MC213		STAINLESS
MC214		DARK IRON
MC218		ALUMINIUM
Mr.COLOR SUPER METALLIC		
SM06		CHROME SILVER

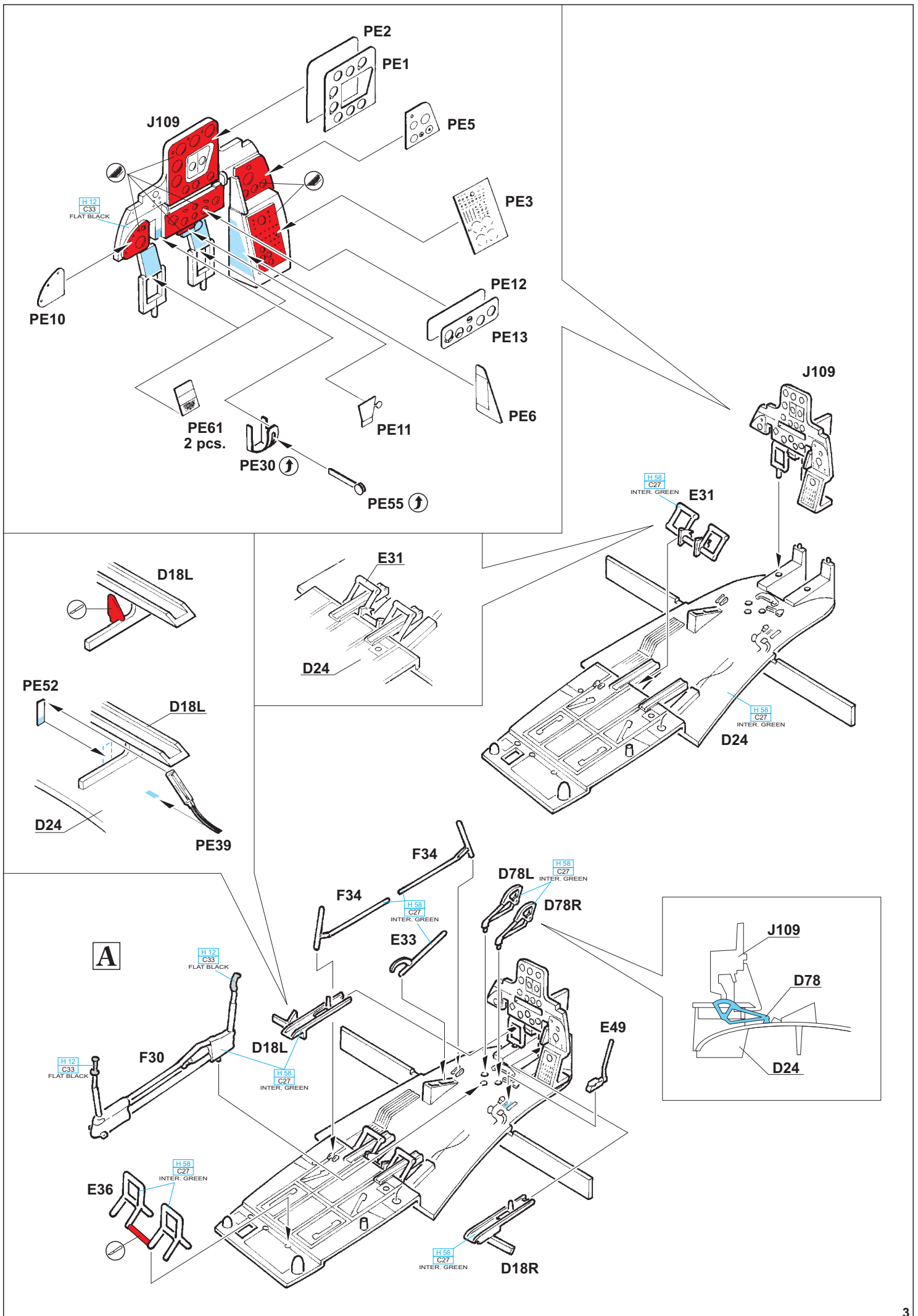

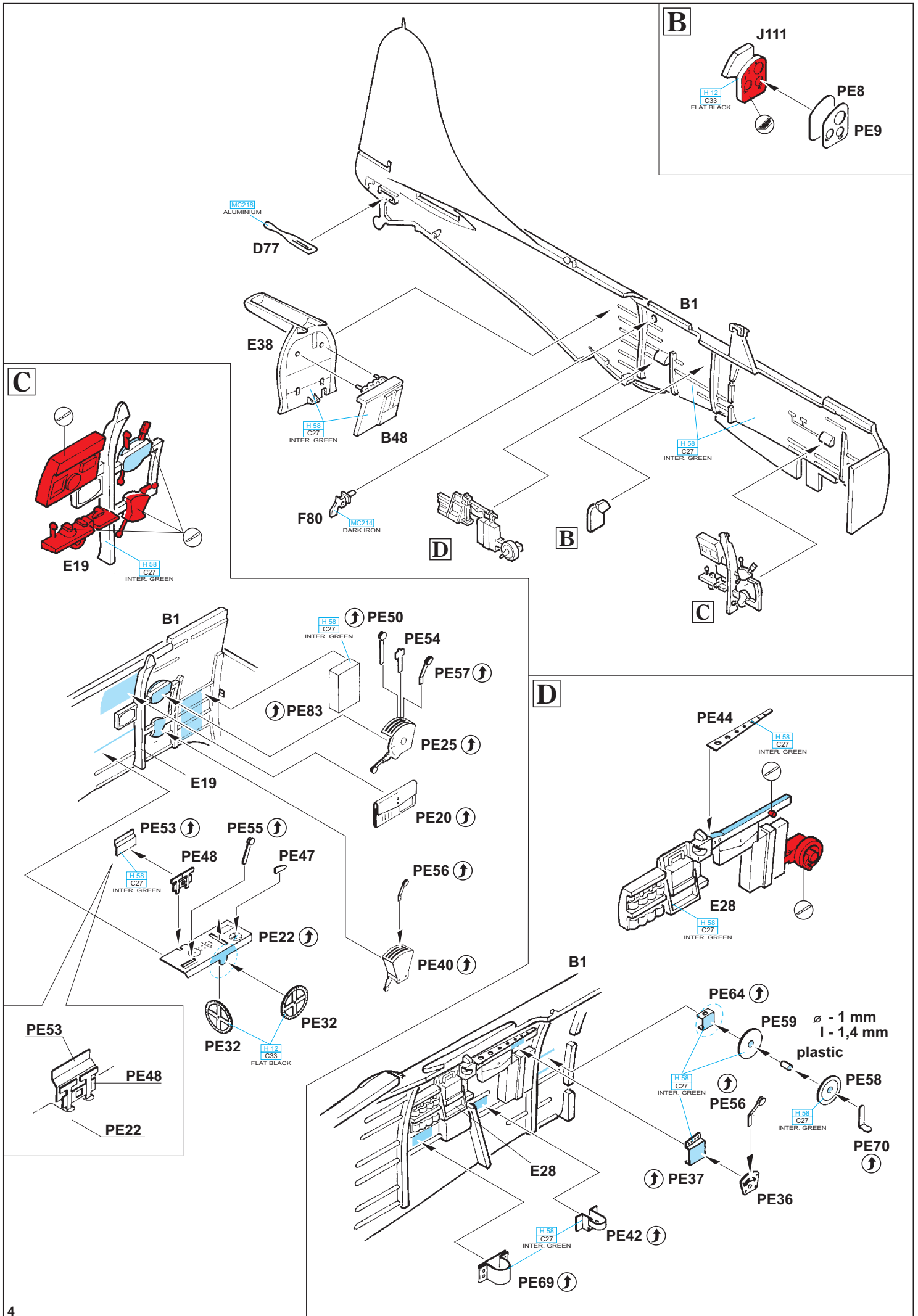

C

B

D

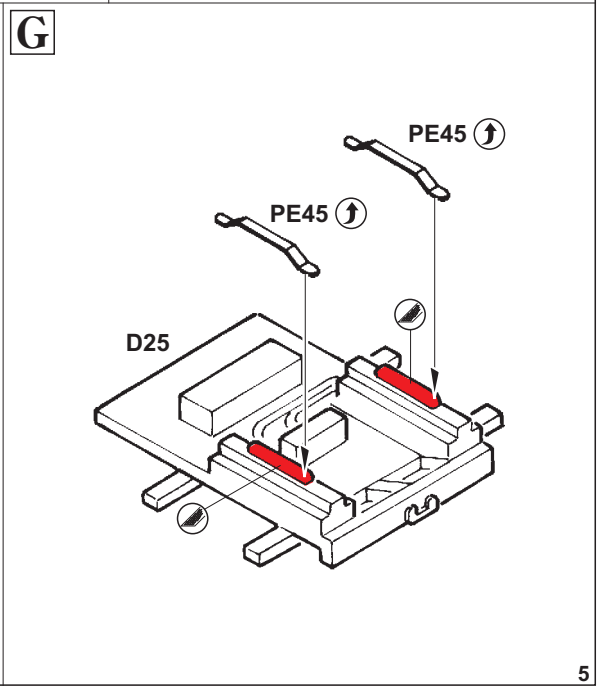
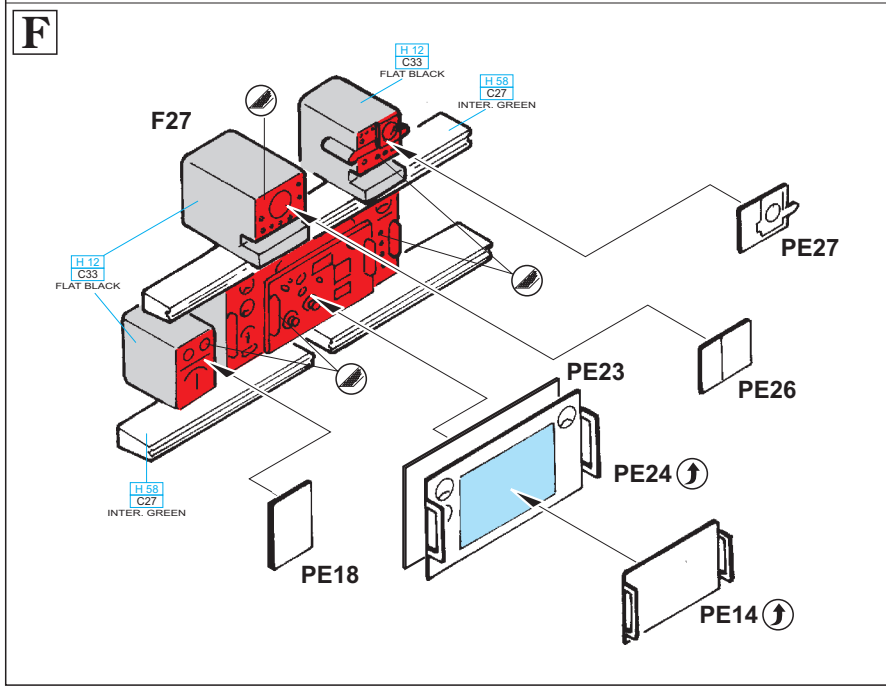
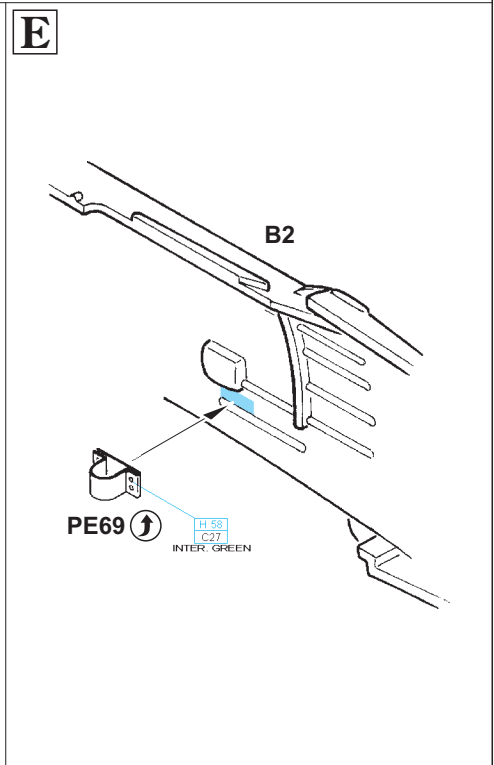
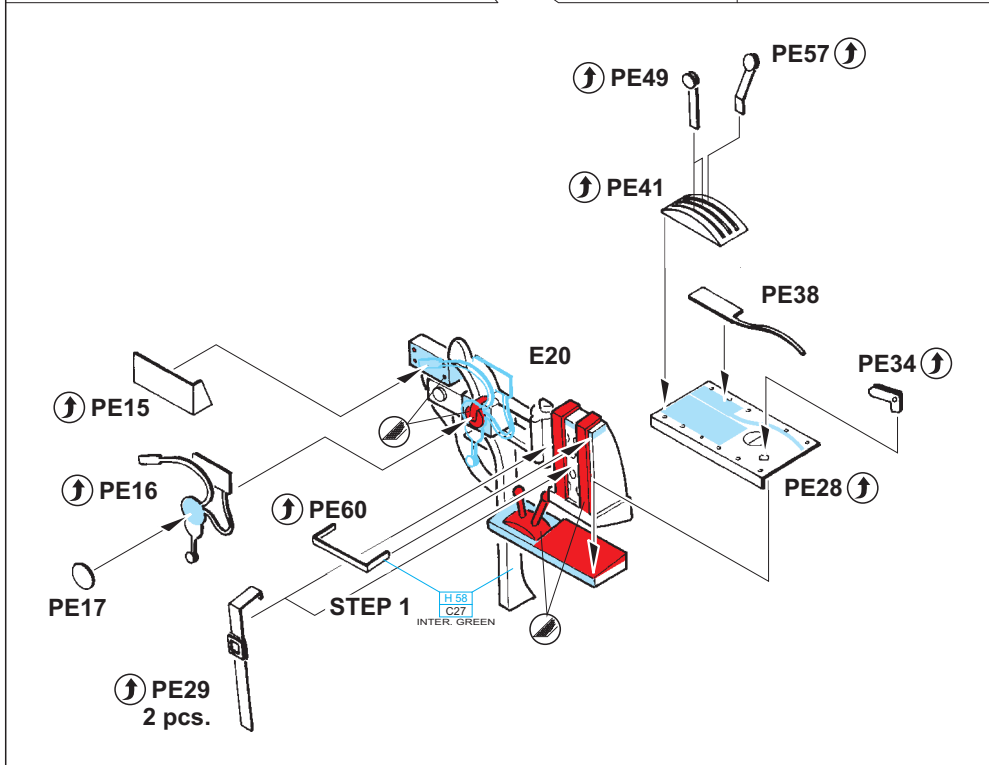
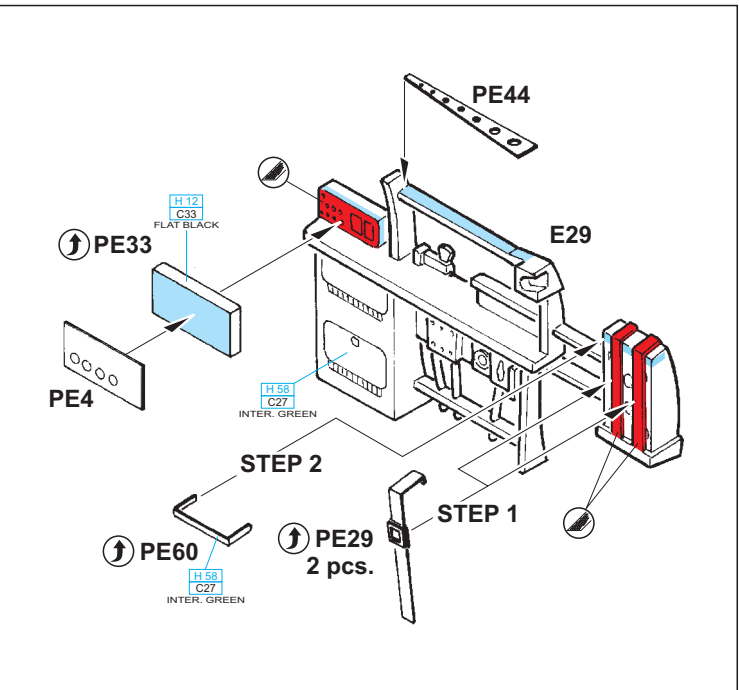
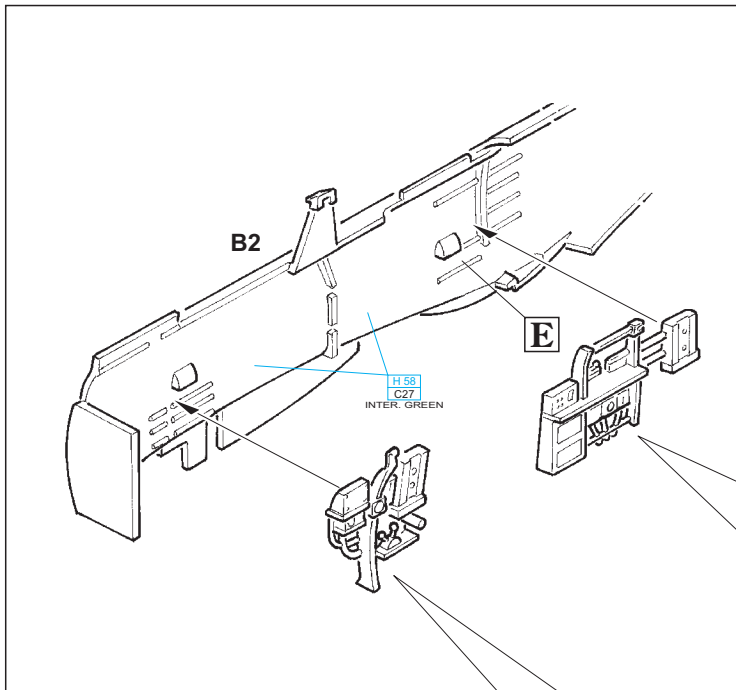

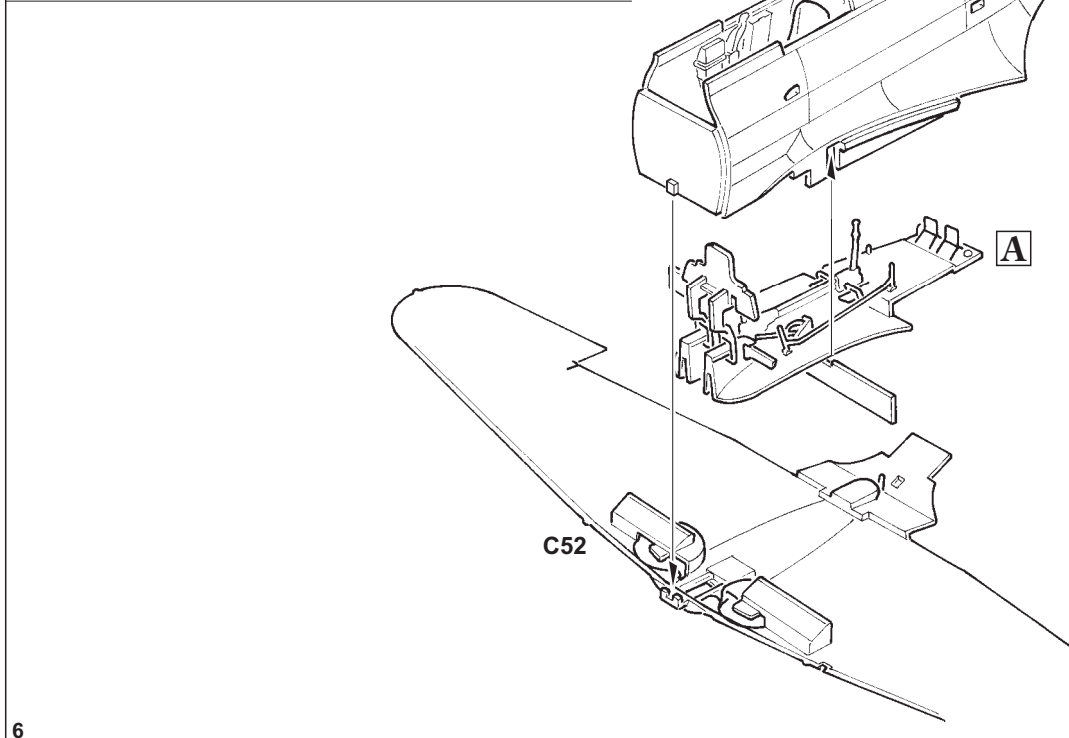
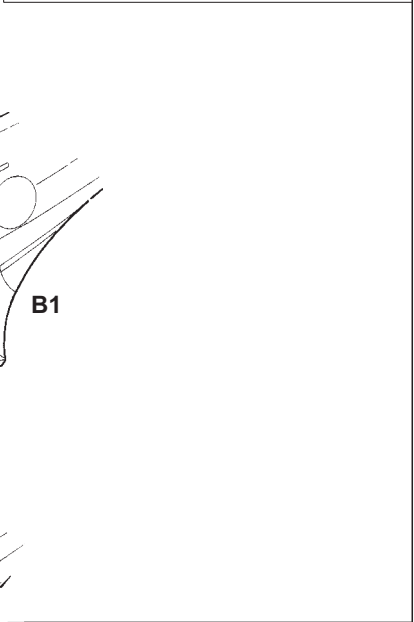
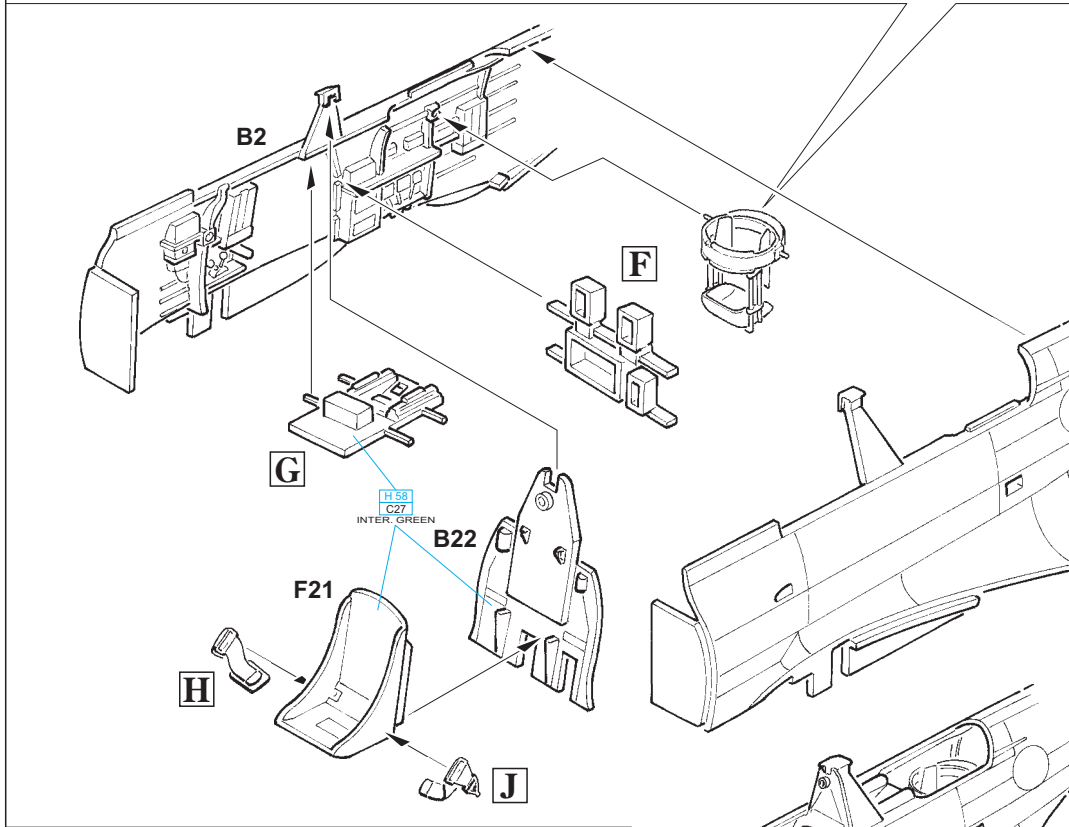
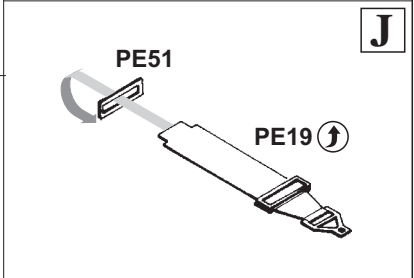
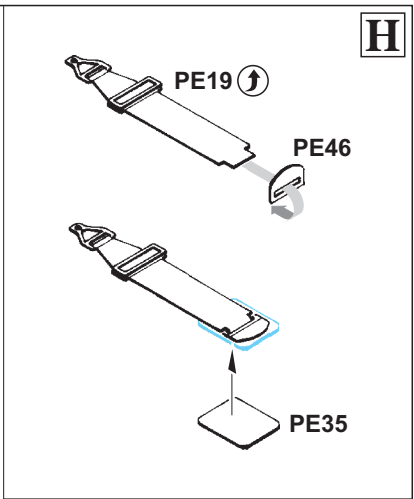
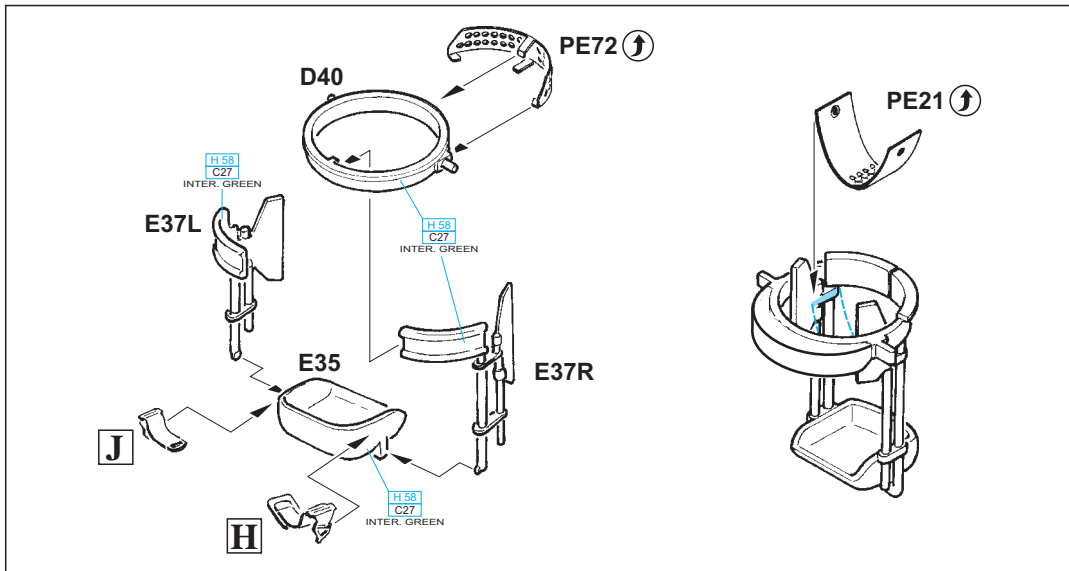

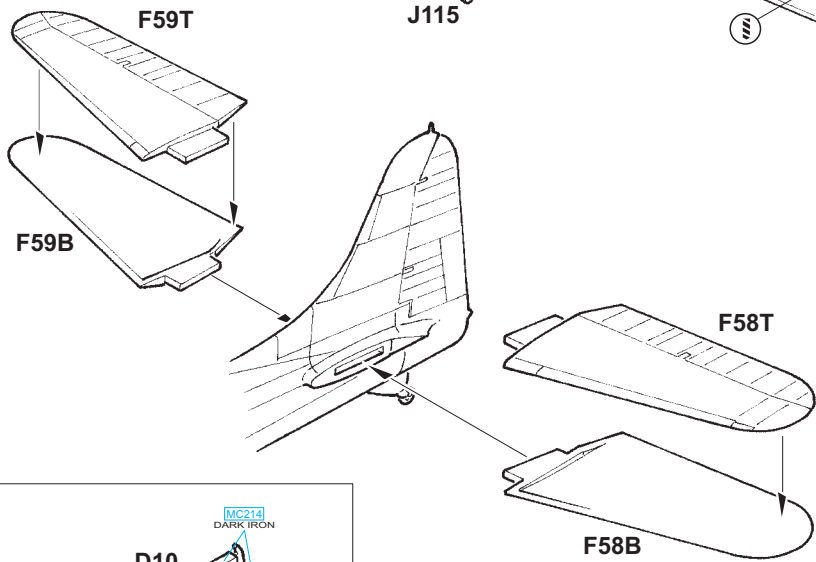
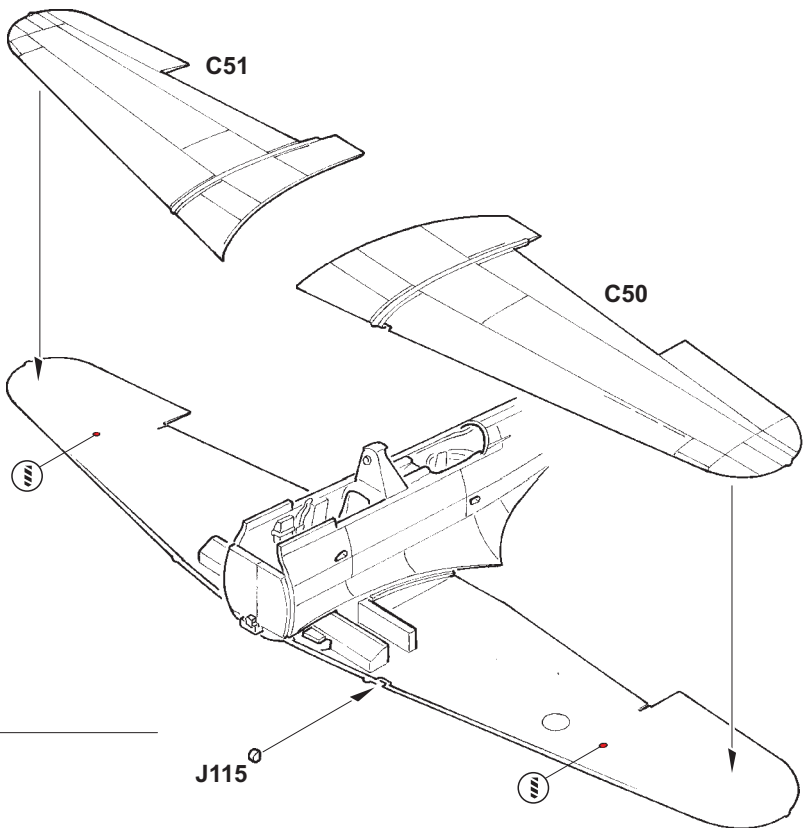

RP5 - MARKINGS A, C, D, E ONLY

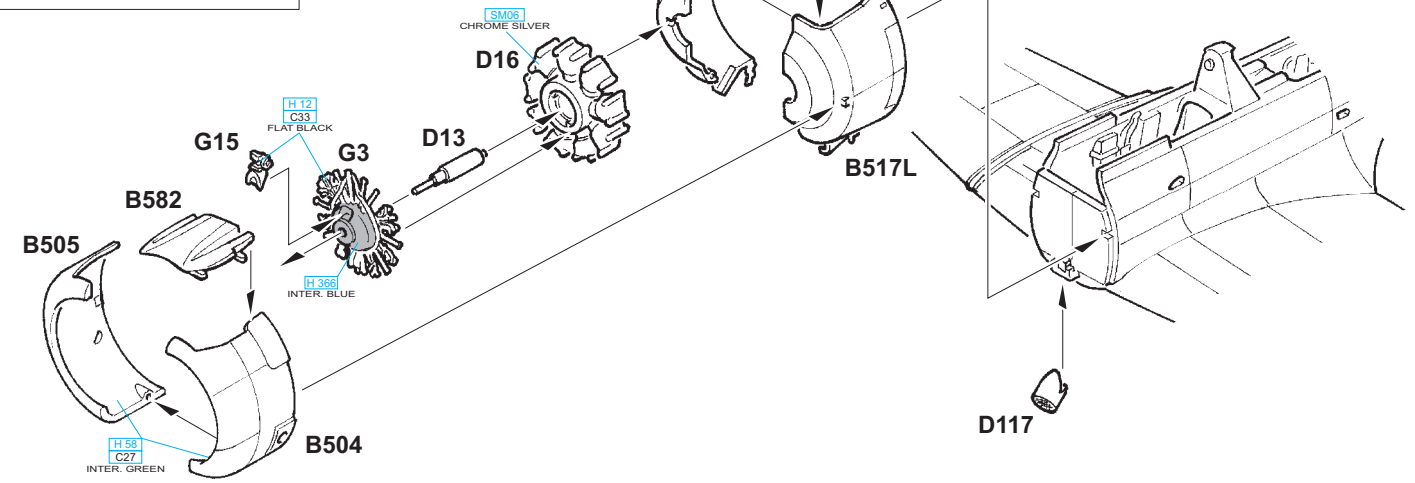
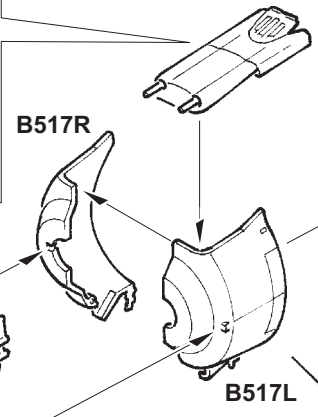
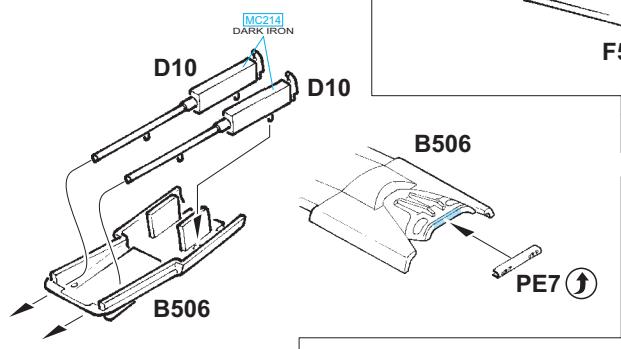
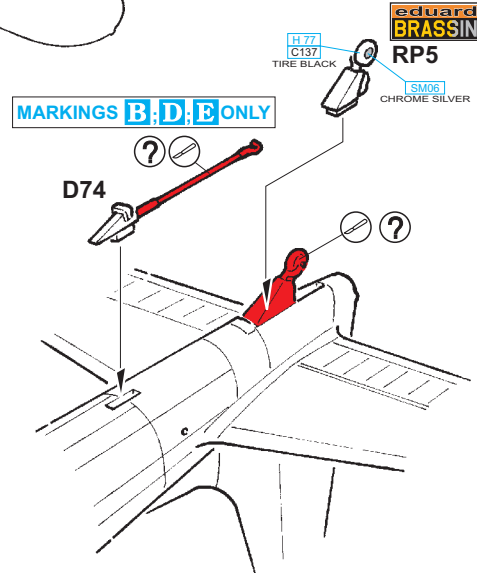

RP1, RP2

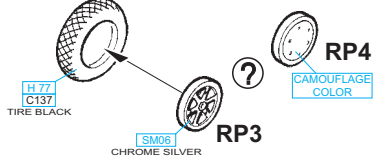

H 77
C137
TIRE BLACK

SM06
CHROME SILVER

RP3

?

RP4
CAMOUFLAGE COLOR

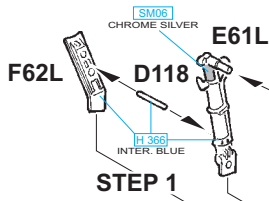

STEP 1

STEP 2

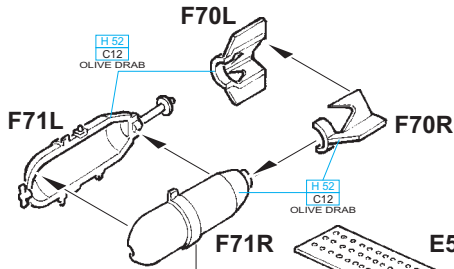

H 52
C12
OLIVE DRAB

H 52
C12
OLIVE DRAB

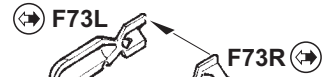

H 52
C12
OLIVE DRAB

H 327
C327
RED

MC218
ALUMINIUM

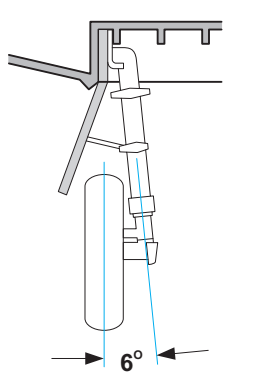

6°

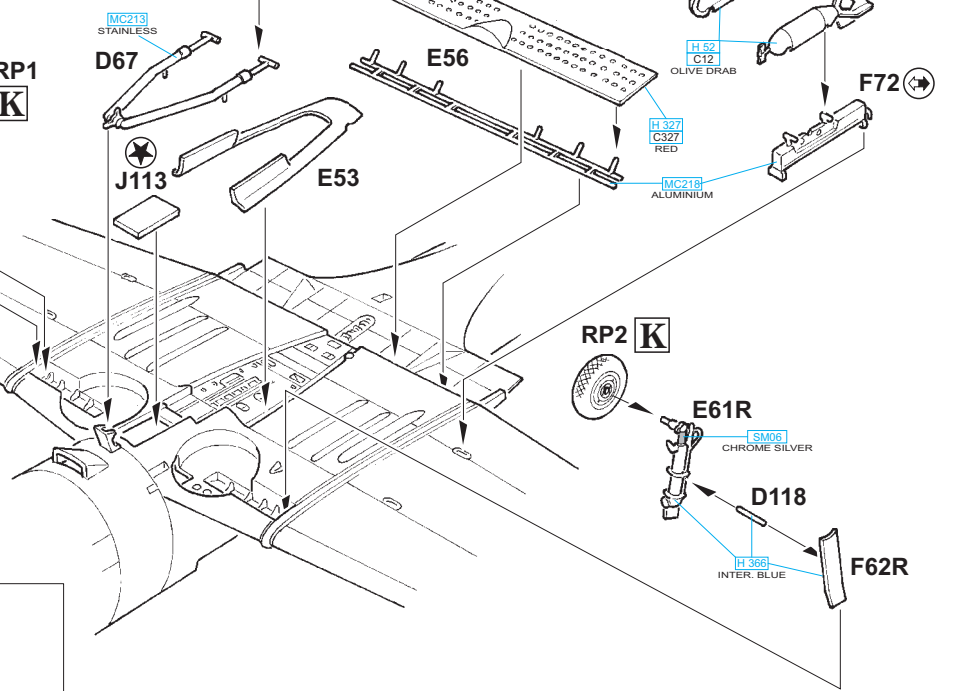

RP2

SM06
CHROME SILVER

H 366
INTER. BLUE

F62R



H 12
C33
FLAT BLACK

G69

J114



H 90
C47
CLEAR RED

H 94
C138
CLEAR GREEN

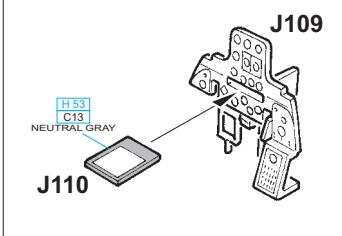

H 53
C13
NEUTRAL GRAY

J110

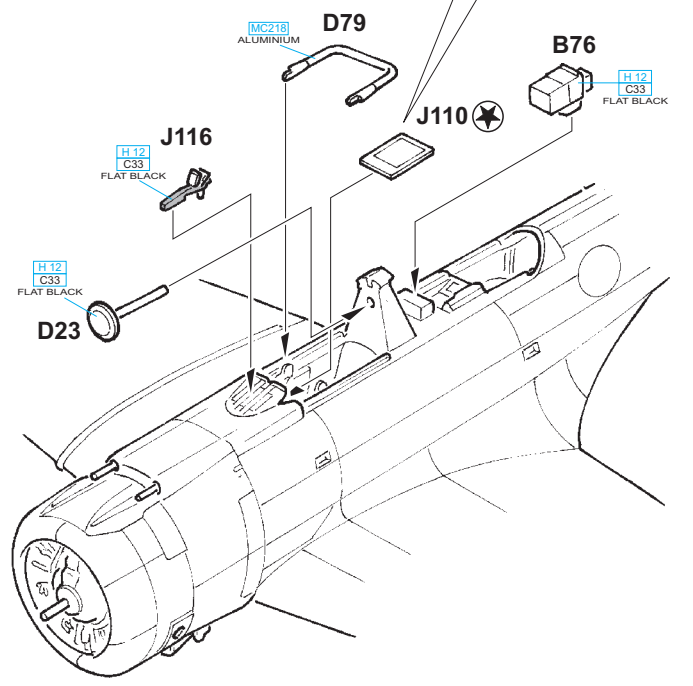

MC218
ALUMINIUM

B76

H 12
C33
FLAT BLACK

H 12
C33
FLAT BLACK

H 12
C33
FLAT BLACK

E81R E81L

H 327
C327
RED

F57R F57L

MC218
ALUMINIUM

H 327
C327
RED

E55R E55L

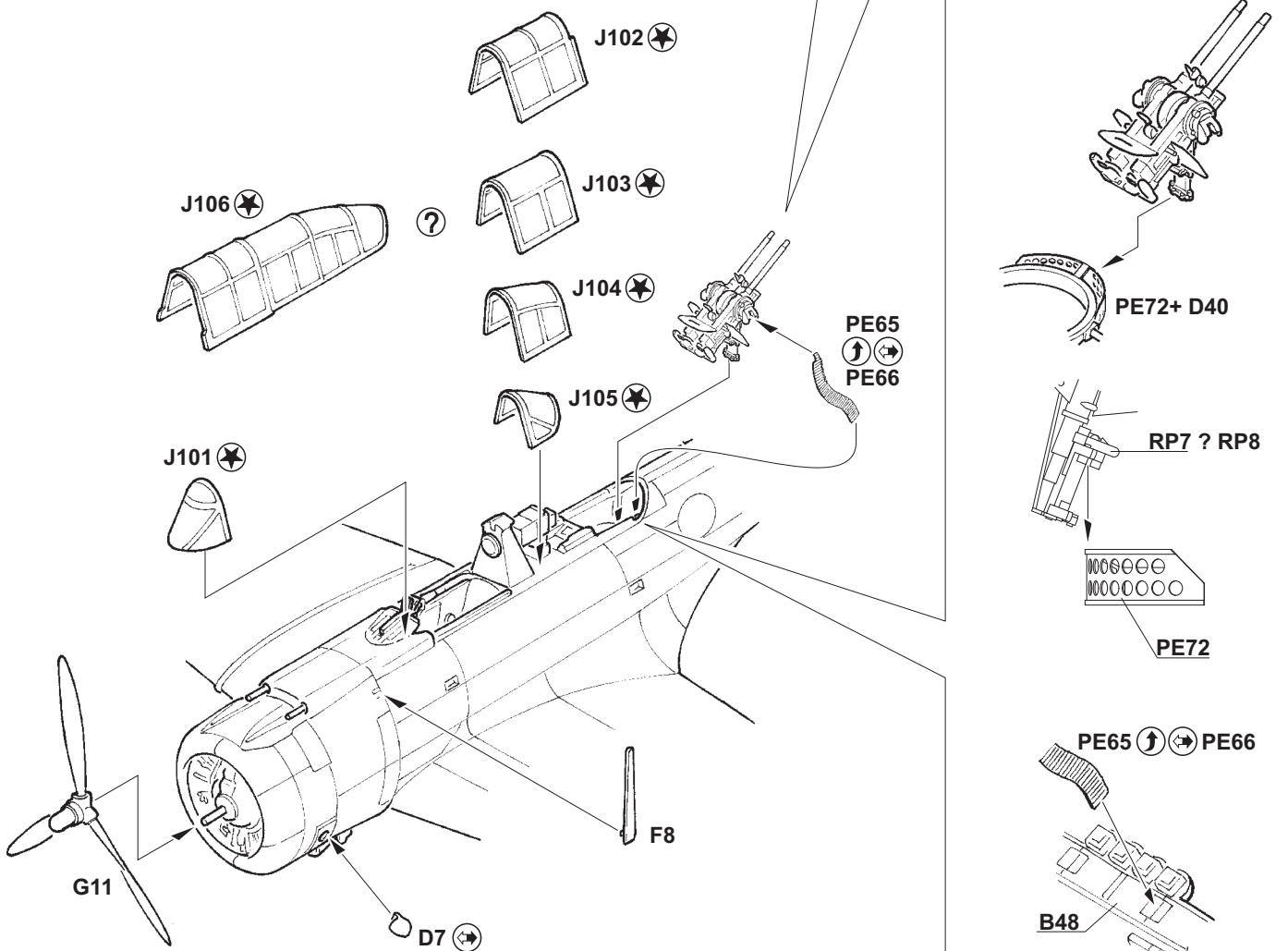
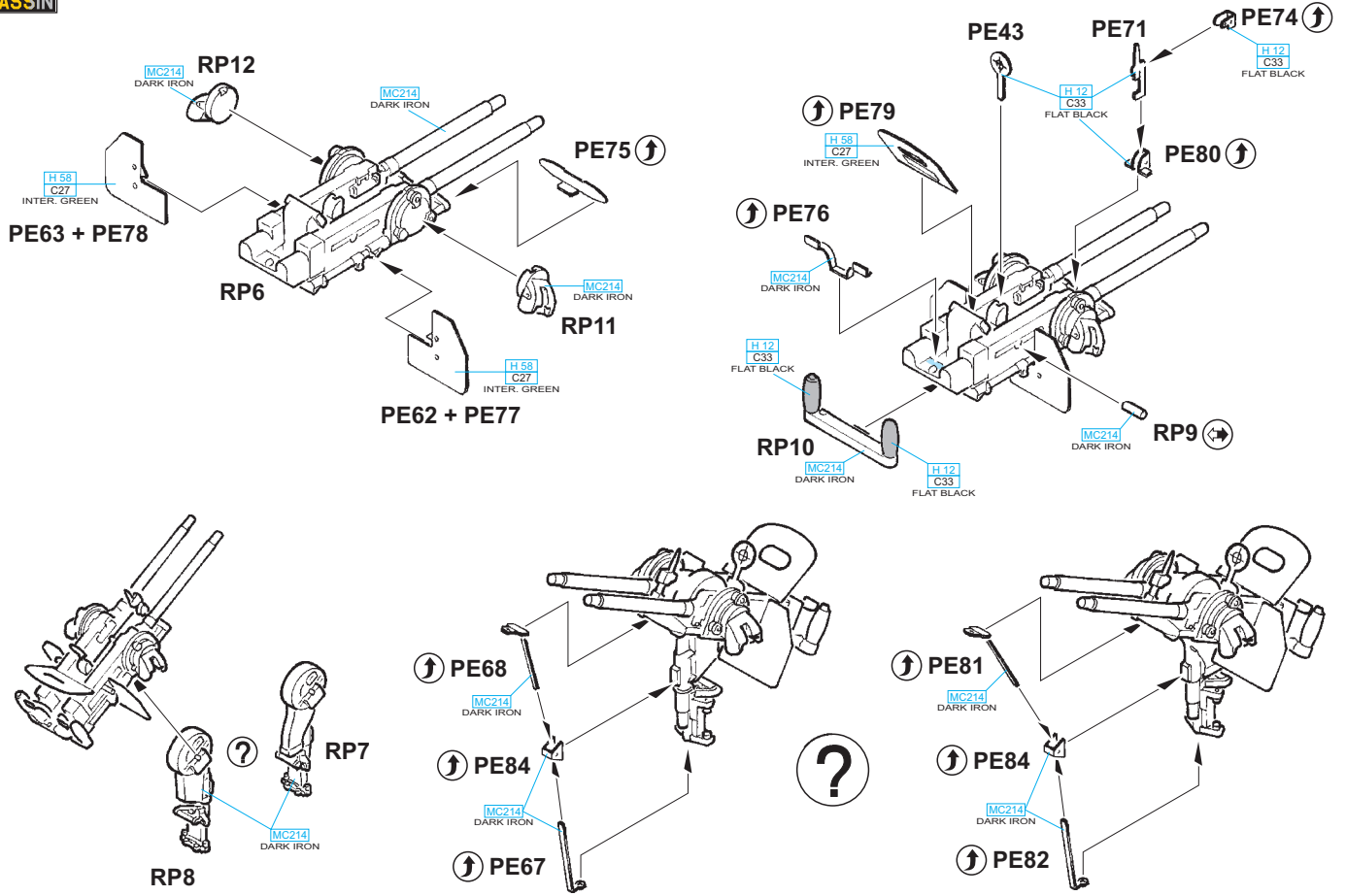

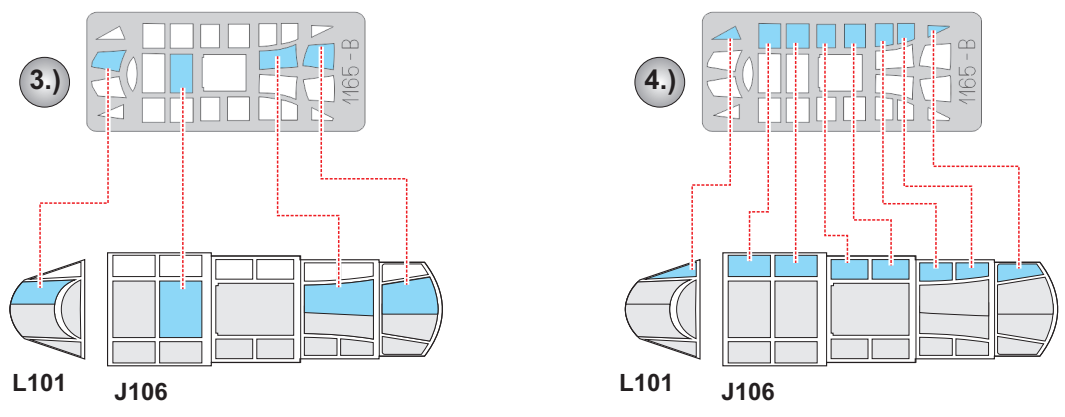
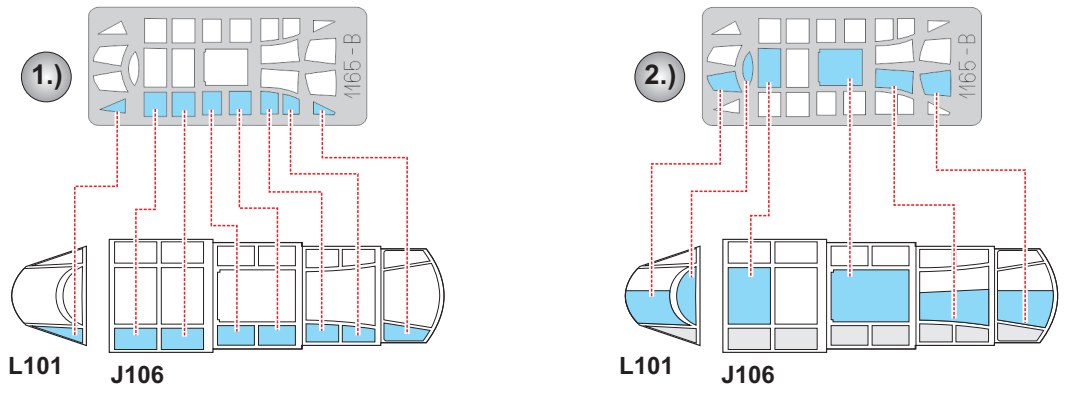
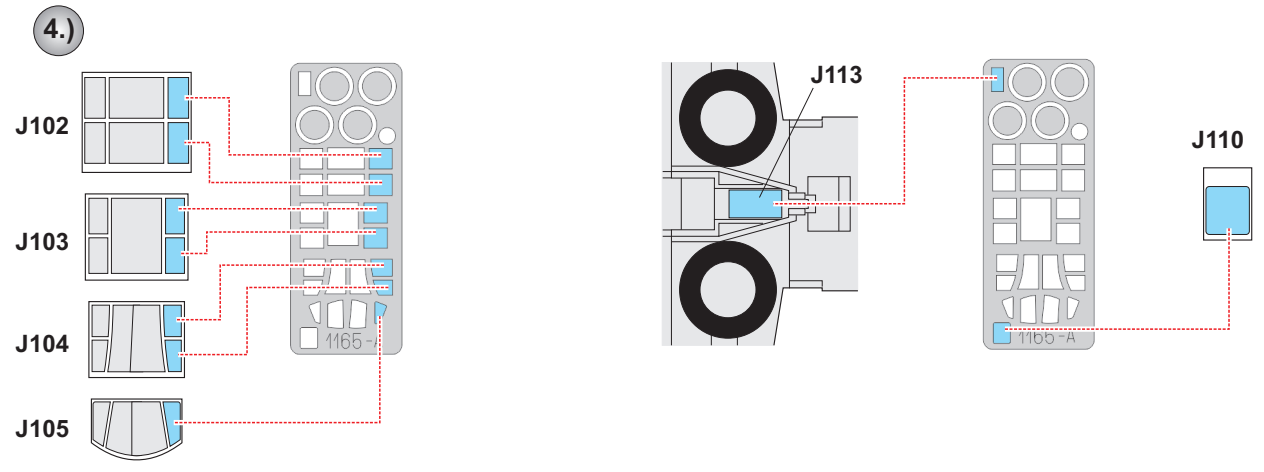
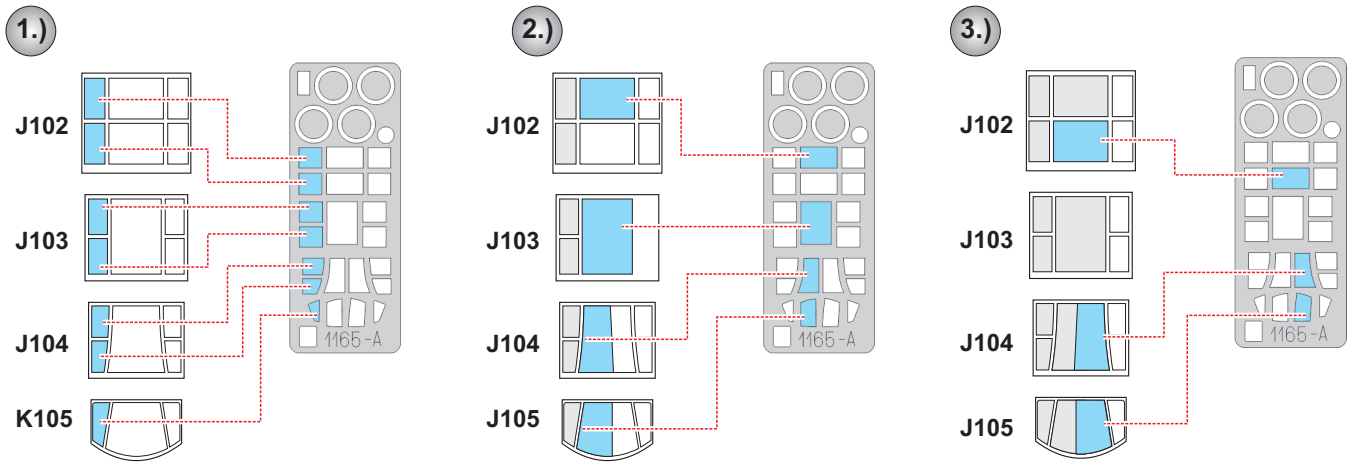
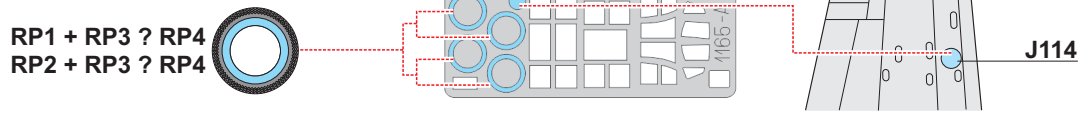

A SBD-5, flown by F/Sgt. C. N. O'Neill / F/Sgt. D. W. Gray, No. 25 Squadron RNZAF, Piva, Bougainville, April, 1944

No. 25 Squadron was the only RNZAF unit using dive bombers, and eighteen SBD-5s were received in February, 1944. From May of the same year, the squadron operated from Piva Air Field on Bougainville. This aircraft was flown by F/Sgt. C. N. O'Neill (pilot) and F/Sgt. D. W. Gray (gunner), and they managed to destroy a fuel dump in Rataval on May 6th, 1944. Two weeks later, the aircraft was returned to the US Marine Corps from which it was borrowed, and the squadron then re-equipped with F4U Corsairs. New Zealand Dauntlesses sported the standard US Navy three tone camouflage scheme, with upper surfaces painted in Semi-Gloss Sea Blue and leading edges in Non-Specular Sea Blue, which is of the same hue, but in a matt finish. The side surfaces were painted in Intermediate Blue and undersides were white. The borders between all colours were soft, hand sprayed without templates. This airplane had a painting of a woman with the inscription 'Paddy's Mistake' on the port side and a white unit badge on the starboard side.

ČESKOU VERZI TEXTU NALEZNETE NA
www.eduard.com/s/1165

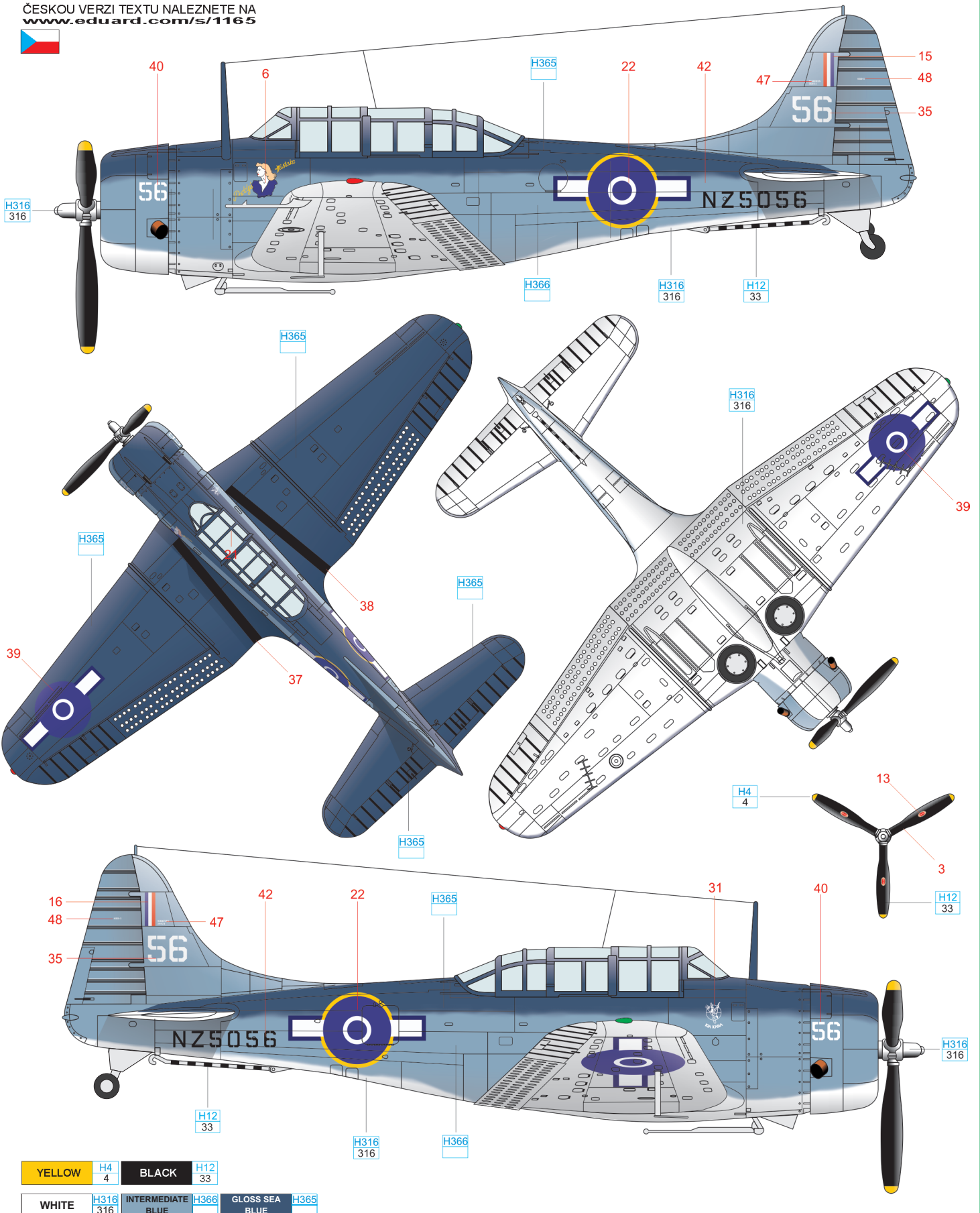

YELLOW	H4 4	BLACK	H12 33
WHITE	H316 316	INTERMEDIATE BLUE	H366
		GLOSS SEA BLUE	H365

B SDB-5, Flown by Maj. Christian C. Lee, CO of VMS-3, Virgin Islands, Spring, 1944

Naval squadron VMS-3 operated from an airfield located on St. Thomas island, which is part of the Virgin Island chain, during the spring of 1944. Apart from SDB Dauntlesses, OS2U Kingfishers were also flown by the unit at that time. The unit was mainly engaged in anti-submarine patrolling, the squadron being disbanded when the potential threat of German U-Boats disappeared. Because the standard Navy three-tone scheme was deemed ineffective for the environment, an order on July 19, 1943 specified two new schemes. The colours of VMS-6 planes consisted of Dark Gull Gray applied on the upper surfaces and part of the fuselage adjacent to the wings. The remaining surfaces, together with the leading edges of the wings and horizontal stabilizer, were painted in Insignia White. Existing photos clearly show the call signs were not painted in black, but rather in Dark Gull Gray.

ČESKOU VERZI TEXTU NALEZNETE NA
www.eduard.com/s/1165

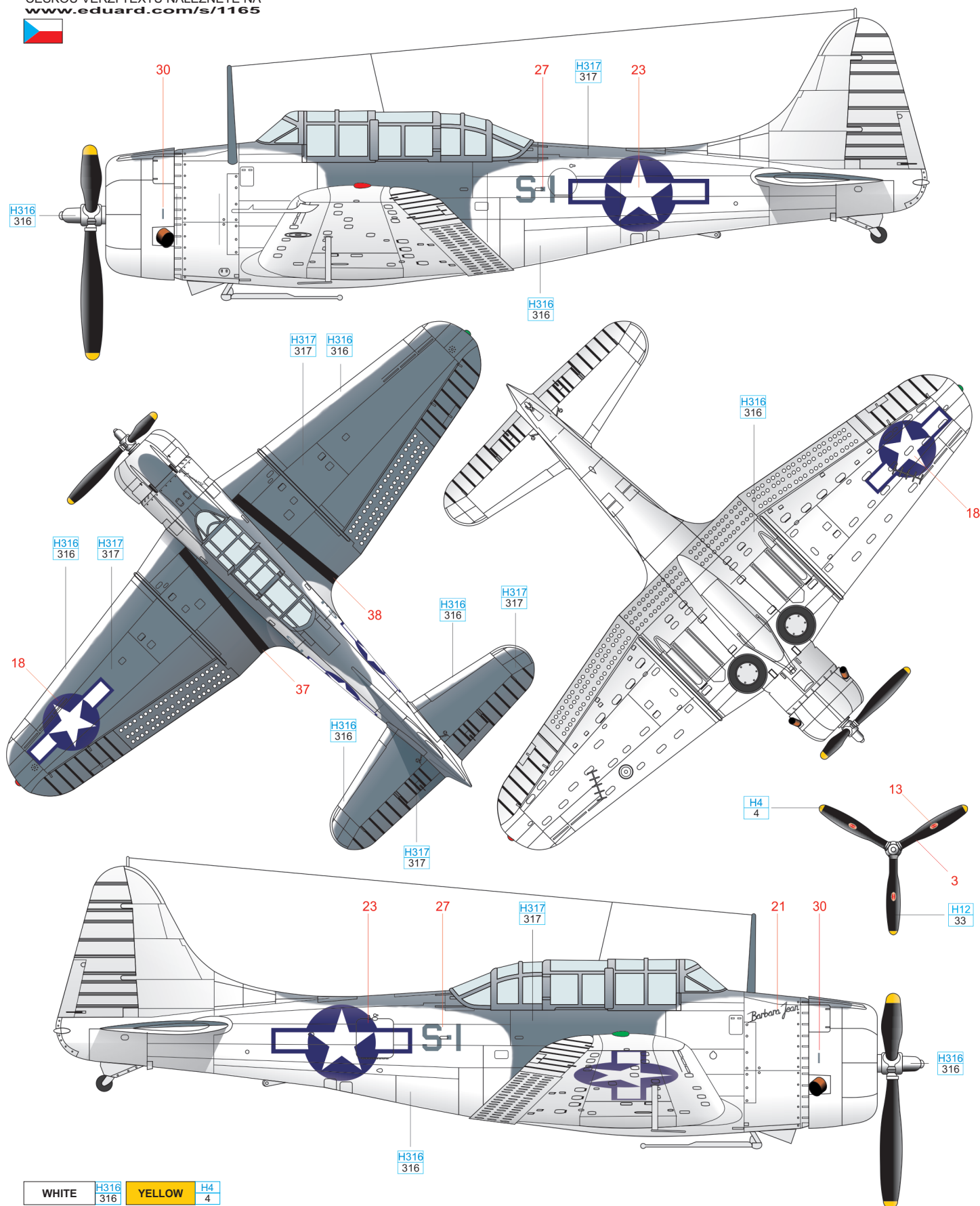

WHITE	H316 316	YELLOW	H4 4
DARK GULL GRAY	H317 317	BLACK	H12 33

eduard

C SBD-5, VMSB-331, Majuro Atoll, Marshall Islands, Spring, 1944

Marine Scout Bomber Squadron VMSB-331 was formed on January 1, 1943 at Marine Corps Air Station Cherry Point, North Carolina. On June 1, 1943, the squadron's personnel and aircraft were divided to form VMSB-332 and also in June of that year, VMSB-331 was moved and became the first squadron to arrive at Bogue Field, North Carolina. Another move occurred in September, the squadron heading for San Diego to prepare for deployment to the South Pacific. The squadron arrived at Nukufetau Airfield on November 15, 1943 and they operated from that atoll during the invasion of the Gilbert Islands. The squadron stayed in the Pacific and carried out air strikes against Japanese positions in the Marshall Islands for the remainder of the war. The emblem of the squadron, a wasp on a bomb, was painted on both sides of the fuselage. The modex 'B-5' was originally white, but later was changed to black with a white outline.

ČESKOU VERZI TEXTU NALEZNETE NA
www.eduard.com/s/1165

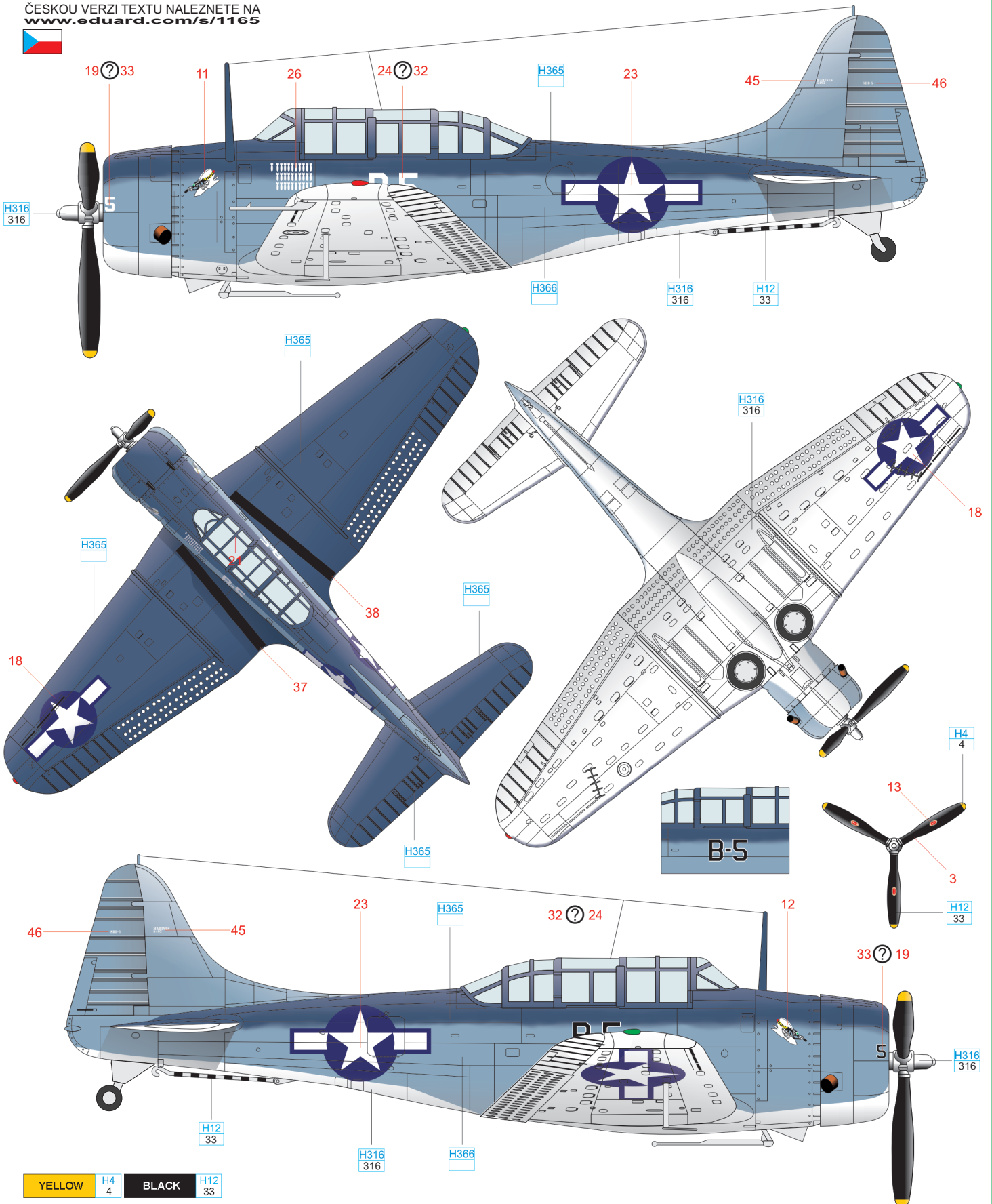

YELLOW	H4 4	BLACK	H12 33
WHITE	H316 316	INTERMEDIATE BLUE	H366
		GLOSS SEA BLUE	H365

D A-24B-1-DO, s/n 42-54298, 407th BG, Amchitka, Summer, 1944

The USAAF used SBD-5s as the A-24B-DT Banshee (DT stands for Douglas and the Tulsa production facility). Flying from land based airfields, the aircraft had their tail hooks removed. The 407th Bomb Group undertook a short-lived combat deployment to Alaska during the summer of 1944. The Banshees received the standard USAAF camouflage of Olive Drab on the upper surfaces and Neutral Gray on the undersides. The insignias had a red outline and were of an unusually large size, converted from the simple star-and-disc originally applied to these aircraft by Douglas Aircraft.

ČESKOU VERZI TEXTU NALEZNETE NA
www.eduard.com/s/1165

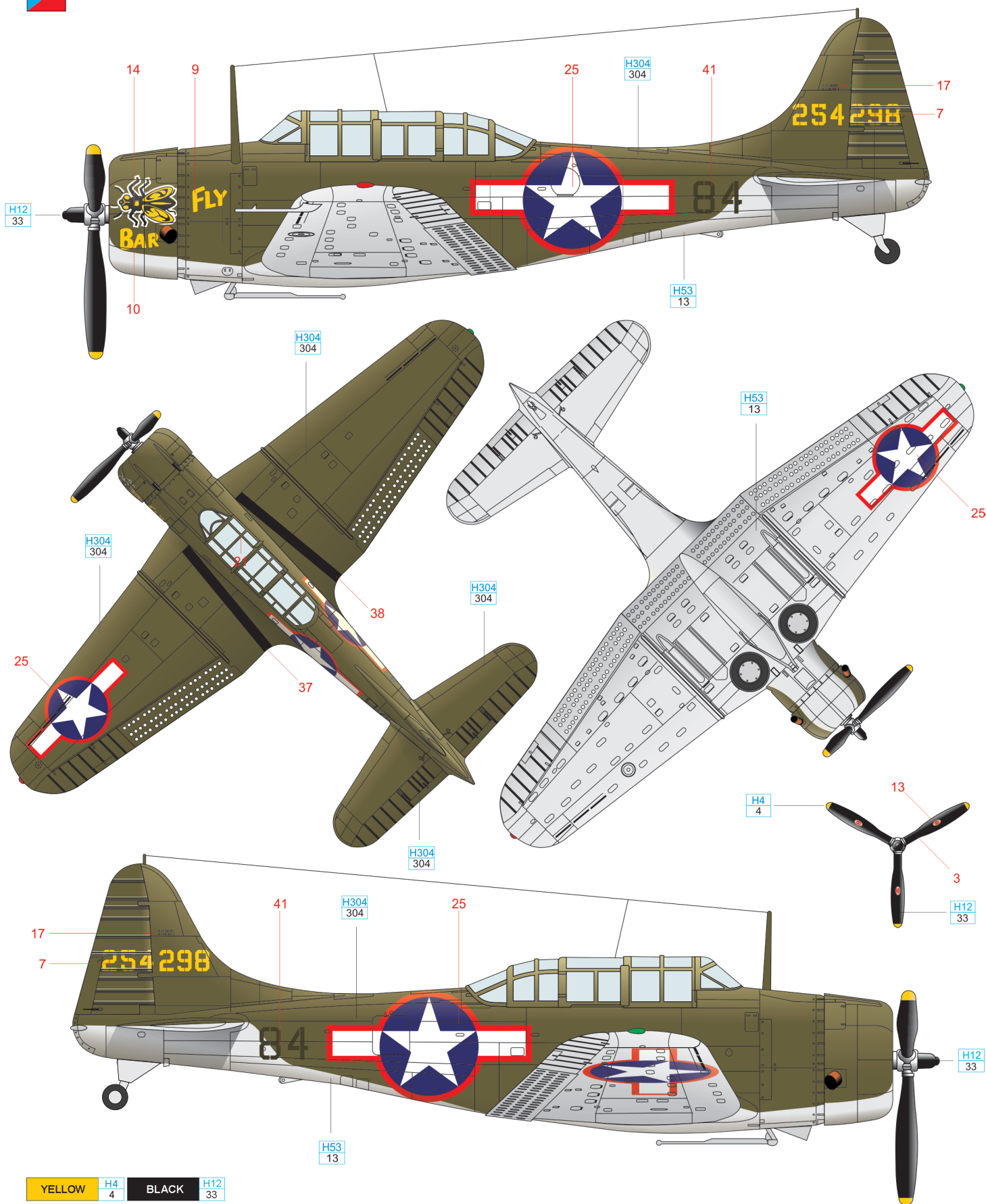

YELLOW	H4 4	BLACK	H12 33
NEUTRAL GRAY	H53 13	OLIVE DRAB	H304 304

E SBD-5. c/n 36817, 4° Flotile de Bombardement de l'Aeronavale, Western France, Early 1945

The French Naval Air Force obtained 32 SBD-5 Dauntlesses at the end of 1944. They were divided among the 4° Flotile de Bombardement and the 3° Flotile de Bombardement units, each receiving sixteen aircraft and using them to support allied forces in western France. The planes were also used in Indochina in 1947 and finally serving out their service lives as training aircraft in the fifties. The planes sported the standard US Navy three tone camouflage scheme. The unit badge was painted under the windscreen on both sides. The yellow bomb silhouettes indicate the number of missions flown.

ČESKOU VERZI TEXTU NALEZNETE NA
www.eduard.com/s/1165



YELLOW	H4 4	BLACK	H12 33	DARK GREEN	H36 23
WHITE	H316 316	INTERMEDIATE BLUE	H366	GLOSS SEA BLUE	H365

