

US SUPERSONIC FIGHTER 1:48 SCALE PLASTIC KIT



eduard

intro

The F-16 Fighting Falcon is a world-wide known multirole jet fighter aircraft. Originally was developed as an air superiority day fighter by General Dynamics for the United States Air Force (USAF). The production was launched in 1976, the type was accepted by USAF in 1979 and more than 4,500 aircraft have been built. Despite of the fact that USAF stopped the purchase of this airplane, improved versions are still being built for export customers.

The Fighting Falcon is a fighter that featured many innovations. The most interesting are a frameless bubble canopy for better visibility, side-mounted control stick to ease control while maneuvering, a seat reclined 30 degrees to reduce the effect of g-forces on the pilot, and the first use of a fly-by-wire flight control system.

The F-16 has a fixed, forward firing M61 Vulcan cannon and has eleven hardpoints for various missiles, bombs and pods. The F-16's official name is "Fighting Falcon", but "Viper" is widely used by its pilots

Beside the U.S.A. many other NATO countries adopted F-16 as the multirole jet aircraft. You can see Falcons with national insignia of following NATO countries - Belgium, Denmark, The Netherlands, Portugal, Norway, Greece, Poland. Italy, another type operator, retired its F-16s a while ago – in May, 2012.

In addition to active duty USAF, Air Force Reserve Command, and Air National Guard units, the aircraft is also used by the USAF Thunderbirds aerial demonstration team and as an aggressor aircraft by the United States Navy.

Naval Strike and Air Warfare Center was the unit that operated F-16As in very interesting aggressor camouflage schemes. This kit offers these schemes in three variations. The colourful mix is topped with a sleek white-red Viper flown by Brig. Gen. R. L. Engel from Edwards AFB.

úvodem

F-16 Fighting Falcon je celosvětově známým stíhacím letounem. Původně vznikl jako stíhač pro vybojování vzdušné převahy v konstrukční kanceláři koncernu General Dynamics na základě objednávky amerického letectva (USAF). Výroba započala v roce 1976, v roce 1979 byl typ přijat do výzbroje USAF a do současnosti bylo postaveno více než 4500 exemplářů. Přestože USAF již přestalo tento letoun nakupovat, pokročilé verze se nadále vyrábí pro zahraniční uživatele.

F-16 přinesla řadu novinek. Mezi nejzajímavější se řadí bublinovitá kabina zajišťující lepší výhled, knipl umístěný na straně kokpitu pro snazší manévrování, sedačka skloněná pod úhlem 30° pro eliminaci přetížení, které působí na pilota, a použití systému fly-by-wire.

F-16 jsou vyzbrojeny pevně montovaným šestihlavňovým kanonem M-61 Vulcan a na jedenáct závěsných bodů lze zavěsit různé typy raket, pum a dalších speciálních podvěsů. Oficiálním názvem letounu je „Fighting Falcon“, nicméně mezi piloty se rozšířila spíše přezdívka „Viper“.

Kromě Států se typ uplatnil v letectvech mnoha členů obranné aliance NATO. Spatřit je můžete v markingu těchto zemí – Belgie, Dánsko, Nizozemí, Portugalsko, Norsko, Řecko, Polsko. Další uživatel, Itálie, vyřadila své F-16 nedávno, v květnu 2012.

V U.S.A. se F-16 ocitly ve výzbroji USAF, Air Force Reserve Command, jednotek Národní gardy, ale také létal u akrobatické skupiny Thunderbirds či v roli Aggressorů u amerického námořnictva.

Naval Strike and Air Warfare Center mělo ve svých řadách několik F-16A ve velmi zajímavém zbarvení, které imitovalo letouny nepřítele. V této stavebnici vám je přinášíme ve třech podobách. Kamuflážní barvy těchto strojů pak ve výběru doplňuje elegantní bílo-červený stroj brigádního generála R. L. Engela ze základny Edwards.

E version A Block 15AM OCU, s/n 90-0947, NSAWC, NAS Fallon, 2003-2008

FOR COMPLETE PROFILE PLEASE REFER
KOMPLETNÍ KAMUFLÁŽNÍ SCHEMA
NALEZNETE NA
www.eduard.com/s/1173

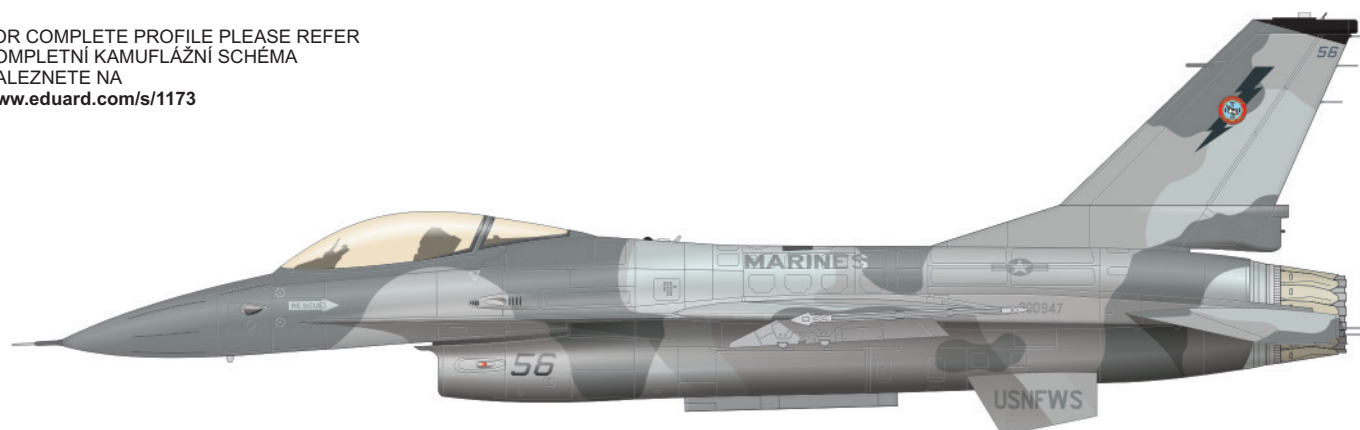

ATTENTION

UPOZORNĚNÍ

ACHTUNG

ATTENTION

注意



Carefully read instruction sheet before assembling. When you use glue or paint, do not use near open flame and use in well ventilated room. Keep out of reach of small children. Children must not be allowed to suck any part, or pull vinyl bag over the head.



Před započetím stavby si pečlivě prostudujte stavební návod. Při používání barev a lepidel pracujte v dobře vetrané místnosti. Lepidla ani barvy nepoužívejte v blízkosti otevřeného ohně. Model není určen malým dětem, mohlo by dojít k požití drobných dílů.



lire soigneusement la fiche d'instructions avant d'assembler. Ne pas utiliser de colle ou de peinture à proximité d'une flamme nue, et aérer la pièce de temps en temps. Garder hors de portée des enfants en bas âge. Ne pas laisser les enfants mettre en bouche ou sucer les pièces, ou passer un sachet vinyl sur la tête.



Von dem Zusammensetzen die Bauanleitung gut durchlesen. Kleber und Farbe nicht nahe von offenem Feuer verwenden und das Fenster von Zeit zu Zeit Belüftung öffnen. Bausatz von kleinen Kindern fernhalten. Verhüten Sie, daß Kinder irgendwelche Bauteile in den Mund nehmen oder Plastiktüten über den Kopf ziehen.



組み立てる前に必ず説明書をお読み下さい。接着剤や塗料をご使用の際は、窓を開けて十分な換気をおこない、火のそばでは使用しないで下さい。小さな子供の手の届かない所に必ず保管してください。部品や破片を噛んだり、なめたり、飲んだりすると大変危険です。又、部品を取り出した後のビニール袋は、小さな子供が頭から被ったりすると窒息する恐れがありますので、破り捨てて下さい。

INSTRUCTION SIGNS * INSTR. SYMBOL * INSTRUKTION SINNBILDEN * SYMBOLES * 記号の説明



OPTIONAL
VOLBA
FACULTATIF
NACH BELIEBEN
選択する



BEND
OHNOU
PLIER SIL VOUS PLAIT
BITTE BIEGEN
折る



OPEN HOLE
VYVRTAT OTVOR
FAIRE UN TROU
OFFNEN
穴を開ける



SYMETRICAL ASSEMBLY
SYMETRICKÁ MONTÁŽ
MONTAGE SYMÉTRIQUE
SYMMETRISCHE AUFBAU
左右均等に組み立てる



NOTCH
ZÁŘEZ
L INCISION
DER EINSCHNITT
切る



REMOVE
ODRÍZNOUT
RETIRER
ENTFERNEN
移す



APPLY EDUARD MASK
AND PAINT
POUŽIT EDUARD MASK
NABARVIT

PARTS

DÍLY

TEILE

PIÈCES

部品

A> **BB>** **C> PLASTIC PARTS** **D> 2 pcs.**

E> **GG>** **G>** **PS>** **NOSE CONE** **CANOPY** **LOWER FUSELAGE** **UPPER FUSELAGE**

J> **M> 2 pcs.** **Z>**

RP - RESIN PARTS
 R1 R2 R3

FILM

PE - PHOTO ETCHED DETAIL PARTS

-Parts not for use. -Teile werden nicht verwendet. -Pièces à ne pas utiliser. -Tyto díly nepoužívejte při stavbě. - 使用しない部品

COLOURS

BARVY

FARBEN

PEINTURE

色

GSI Creos (GUNZE)		
AQUEOUS	Mr.COLOR	
[H 3]	C3	RED
[H 5]	C5	BLUE
[H 8]	C8	SILVER
[H 11]	C61	WHITE
[H 12]	C33	FLAT BLACK
[H 37]	C43	WOOD BROWN
[H 50]		LIME GREEN
[H 54]	C14	NAVY BLUE
[H 56]	C72	INTERMEDIATE BLUE

AQUEOUS	Mr.COLOR	
[H 77]	C137	TIRE BLACK
[H 90]	C47	CLEAR RED
[H 94]	C138	CLEAR GREEN
[H 305]	C305	GRAY
[H 306]	C306	GRAY
[H 307]	C307	GRAY
[H 308]	C308	GRAY
[H 310]	C310	BROWN
[H 316]	C316	WHITE

AQUEOUS	Mr.COLOR	
[H 322]	C322	FS 35109
[H 324]	C324	LIGHT GRAY
[H 346]		FS 30279
Mr.METAL COLOR		
[MC214]		DARK IRON
Mr.COLOR SUPER METALLIC		
[SM03]		SUPER IRON
[SM04]		SUPER STAINLESS
[SM06]		CHROME SILVER

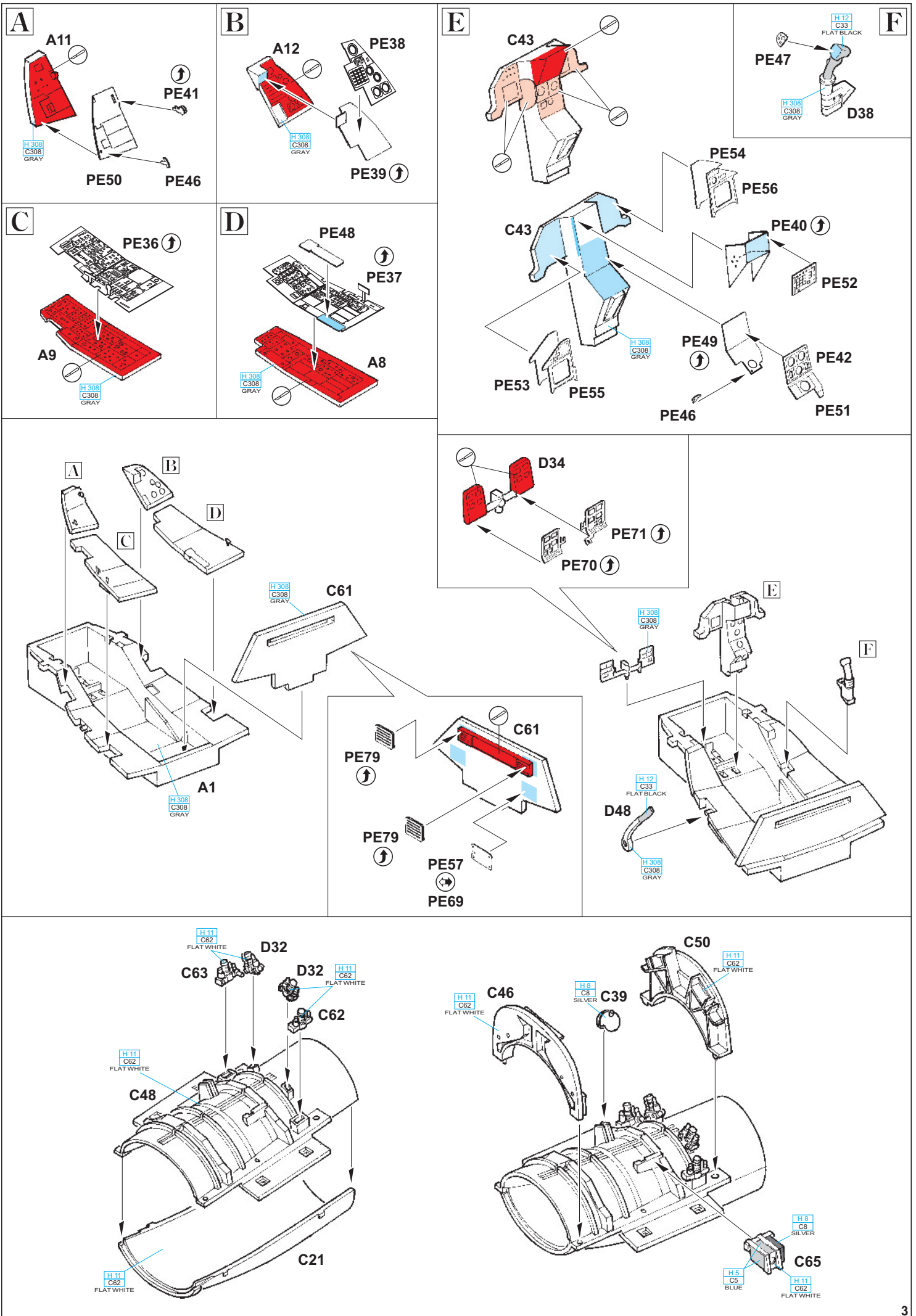

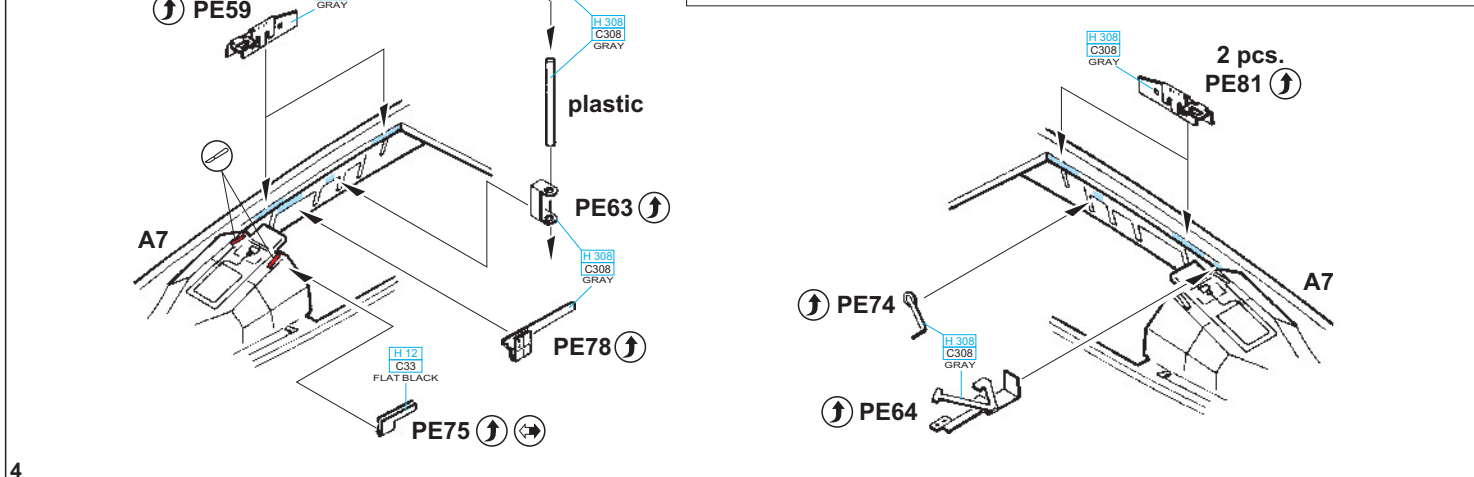
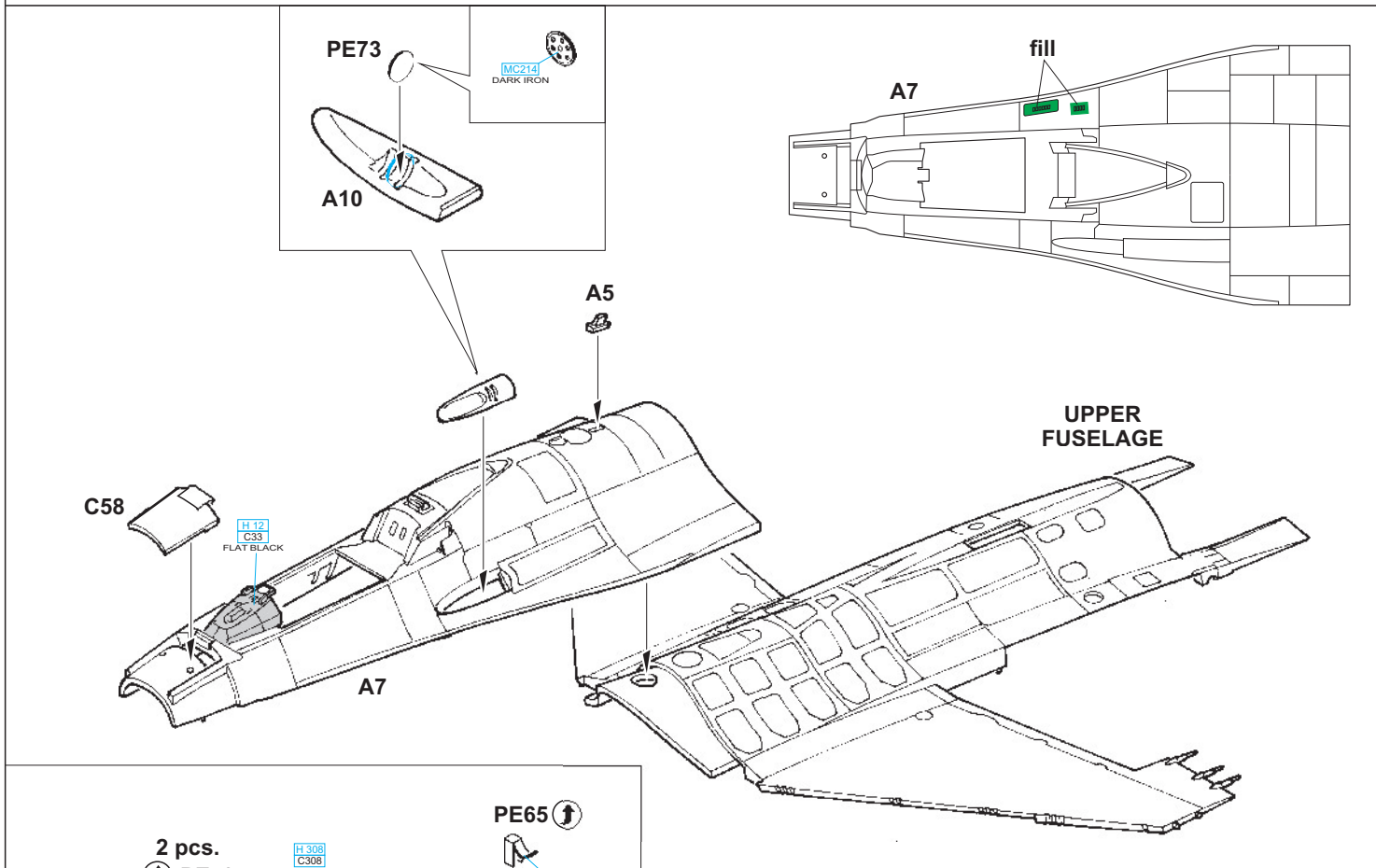
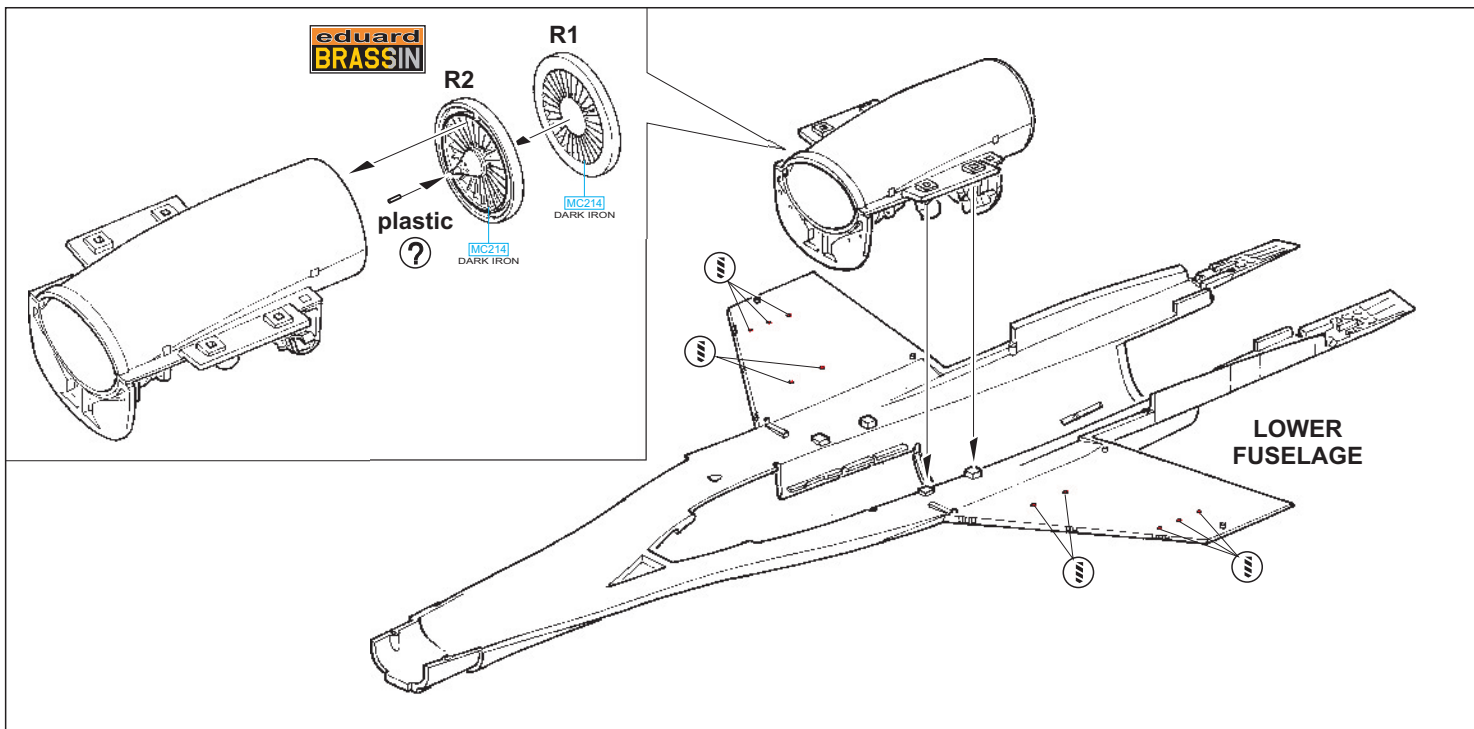

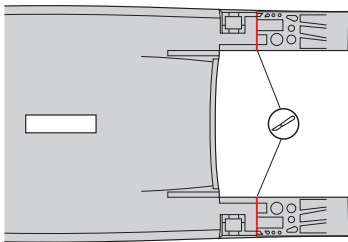
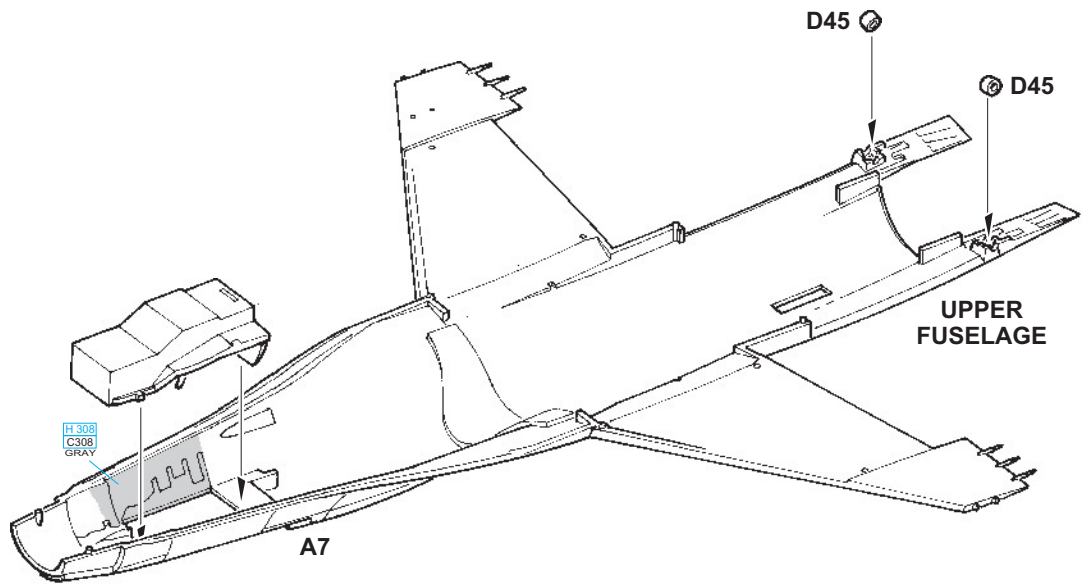

UPPER FUSELAGE

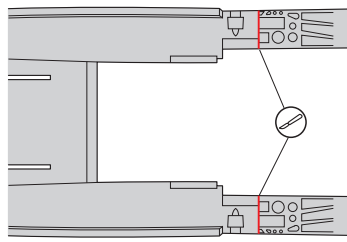

LOWER FUSELAGE

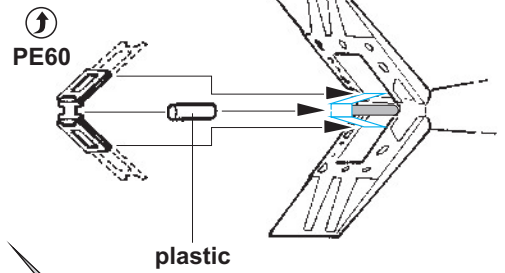

PE60

plastic

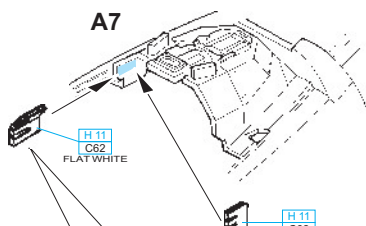

A7

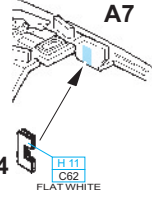

A7



PE44

H 11 C62 FLAT WHITE

PE43



PE45

H 11 C62 FLAT WHITE

Z7

H 308 C308 GRAY

Z3

Z3

C66

C12

C10

LOWER FUSELAGE

PE82

PE76



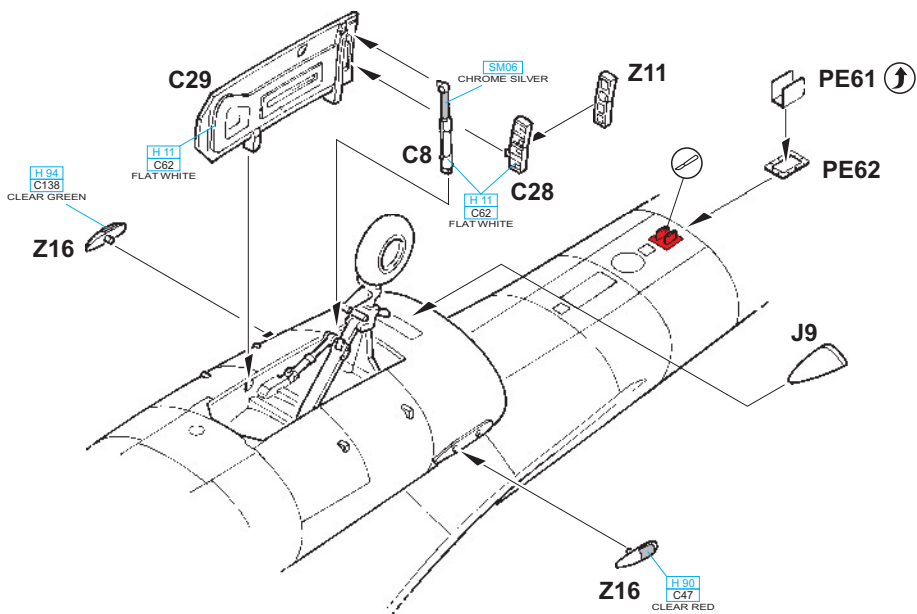
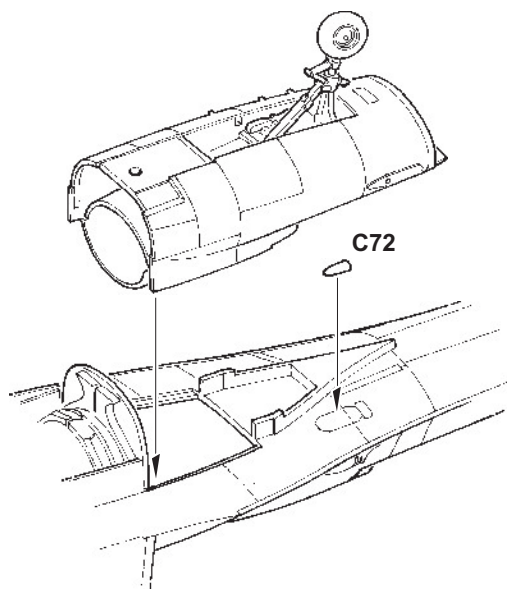
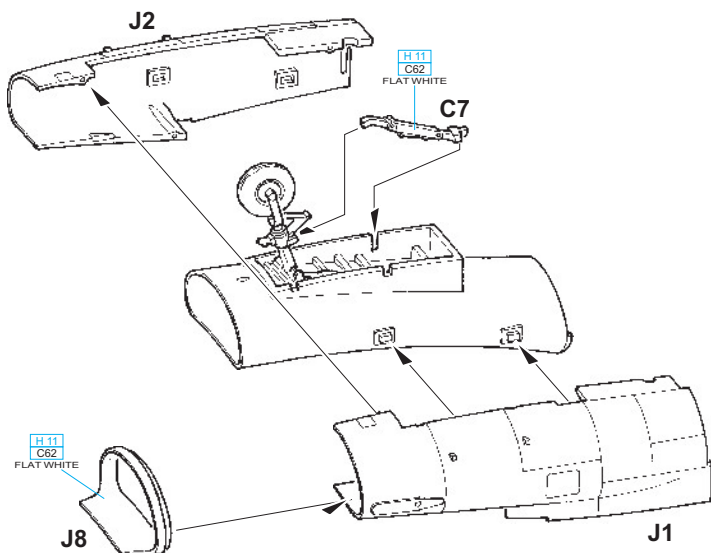
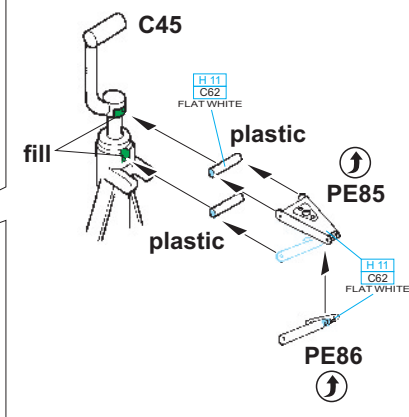
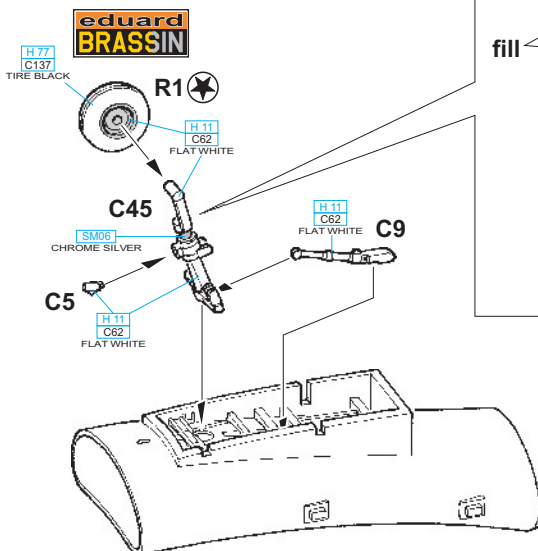
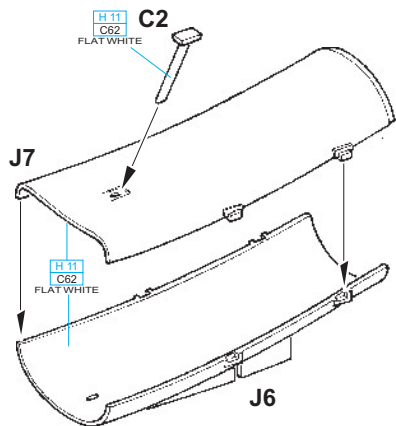

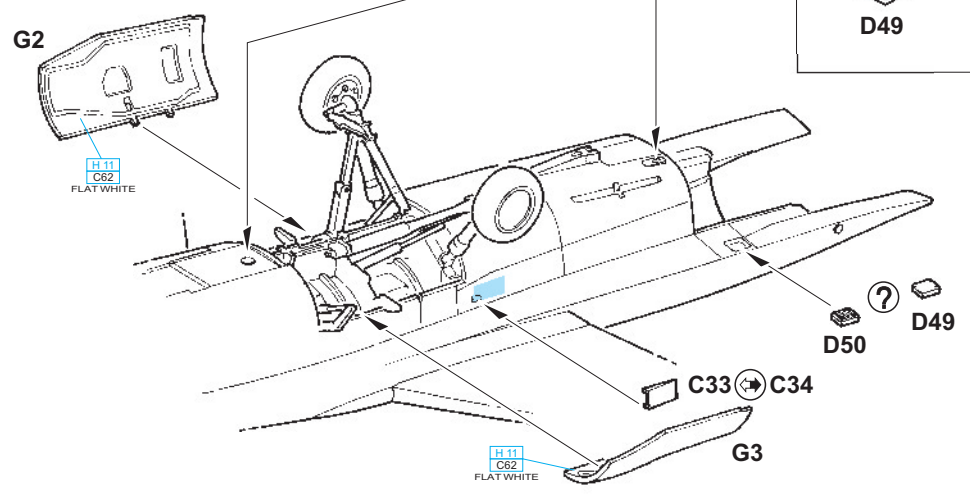
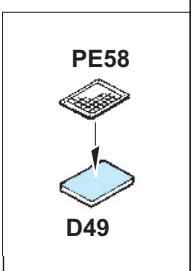
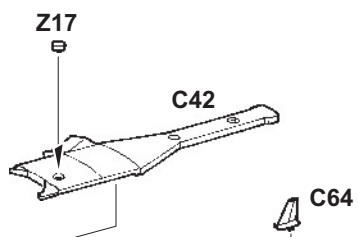
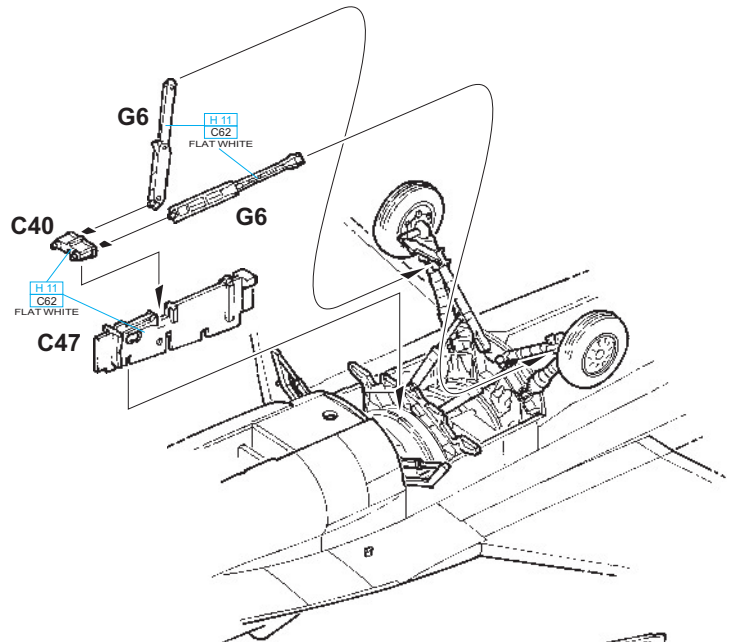
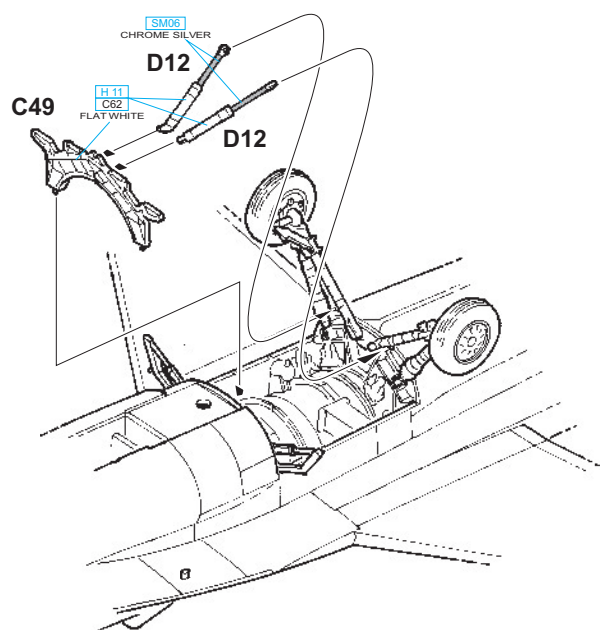
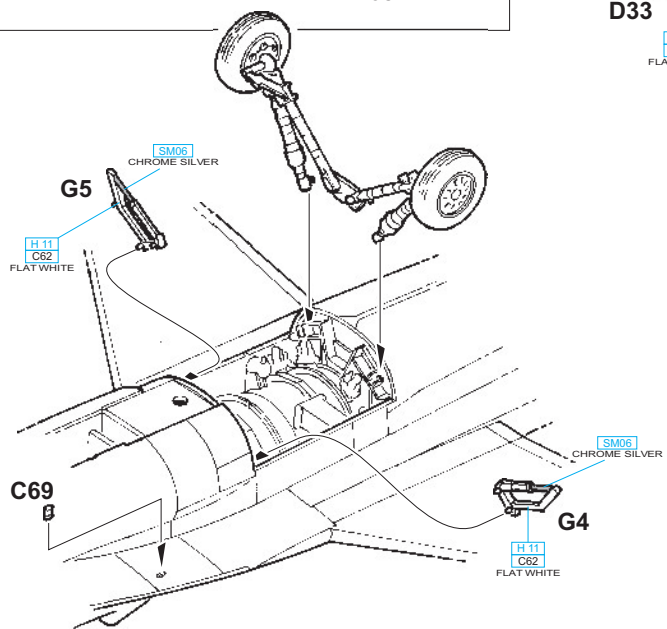
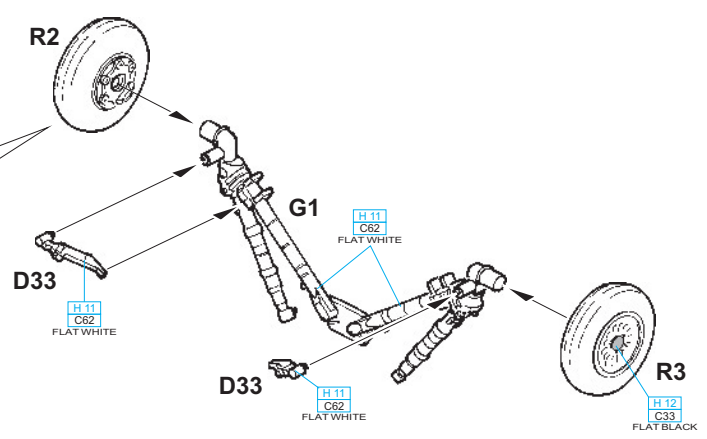
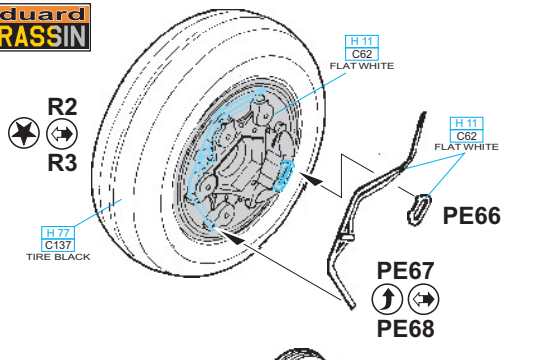

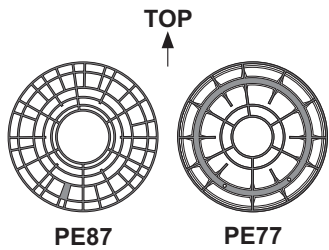

PE87

PE77

eduard
BRASSIN

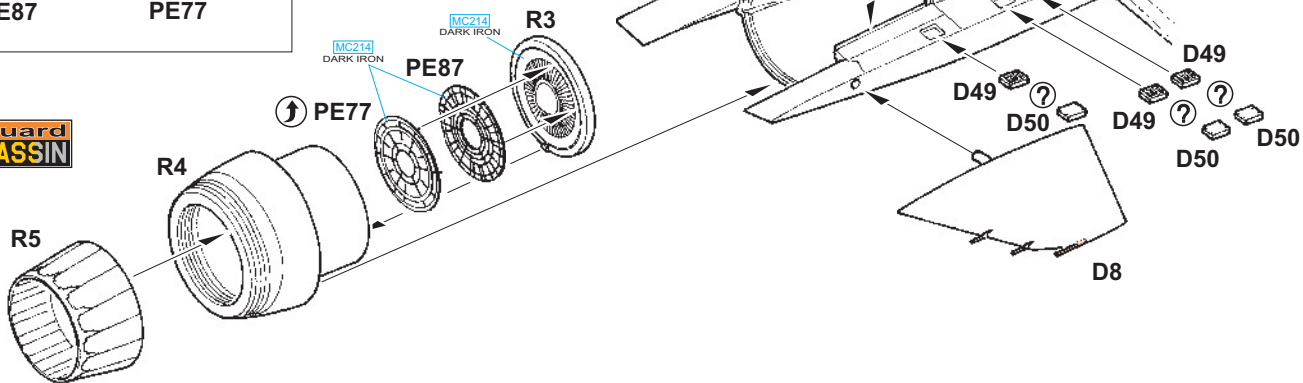

PE58

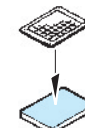

D49
3 pcs.

C55+C70

C54+C71

C20

C19

eduard
MASK

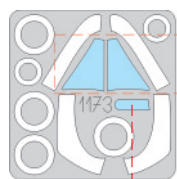

CANOPY

Z15

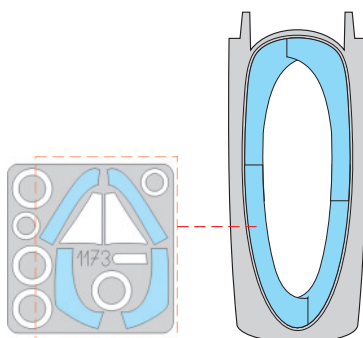

PE84
3 pcs.

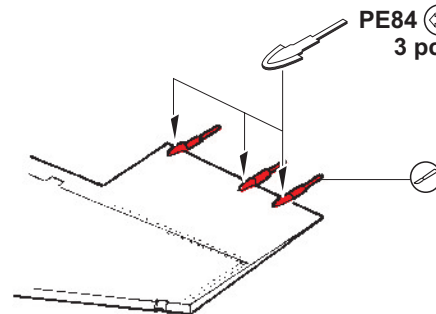

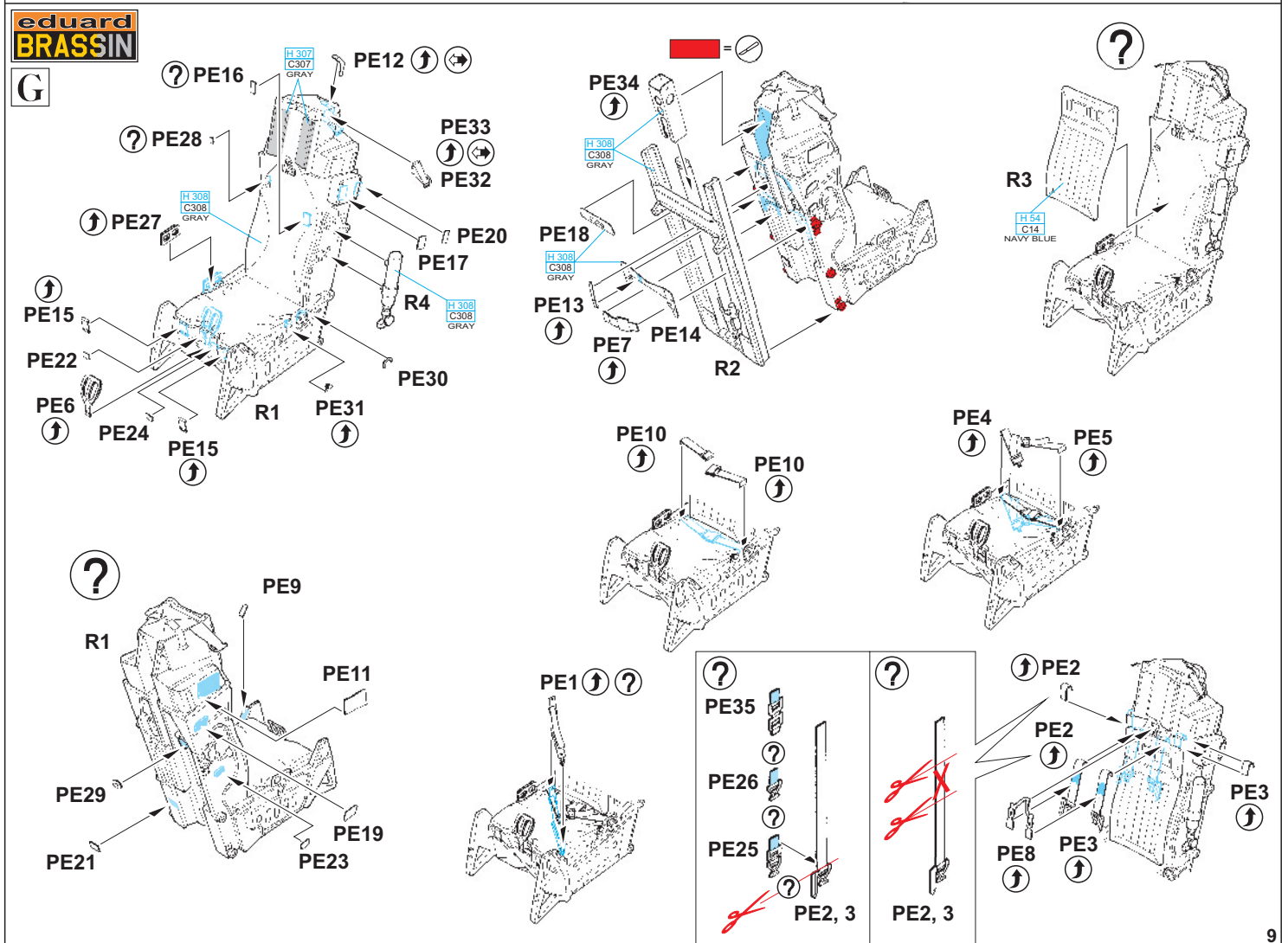
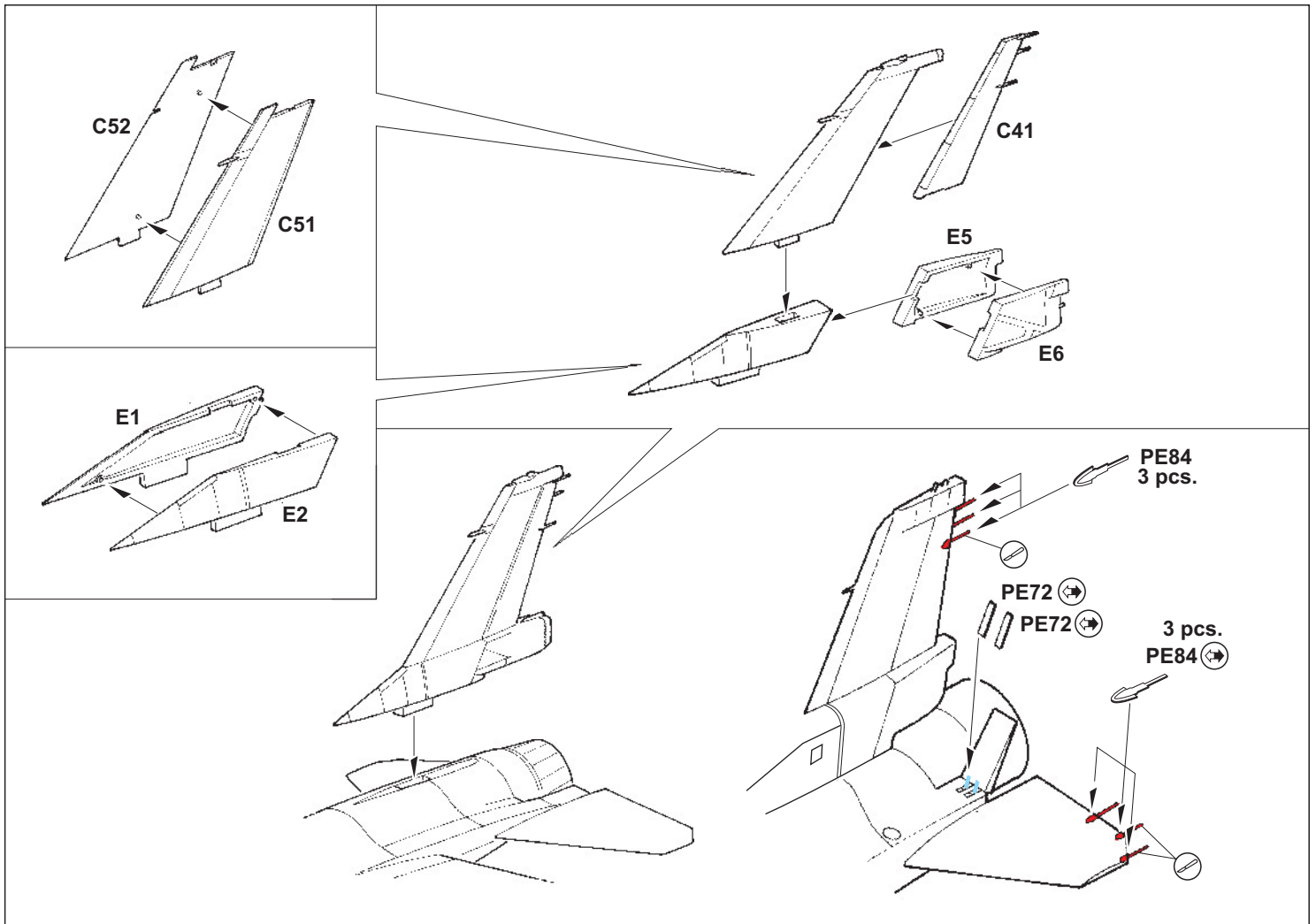

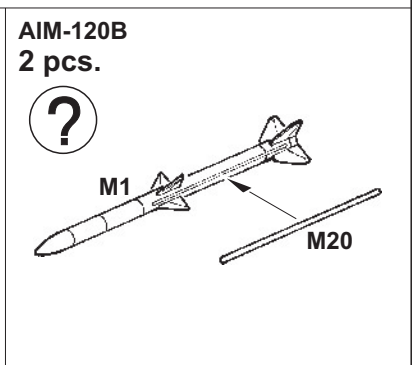
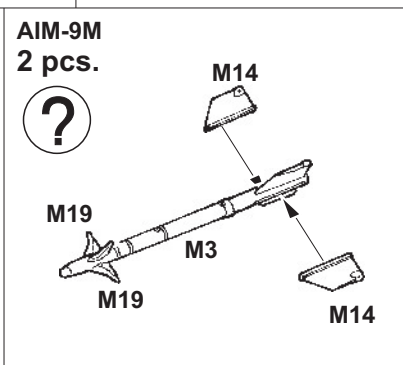
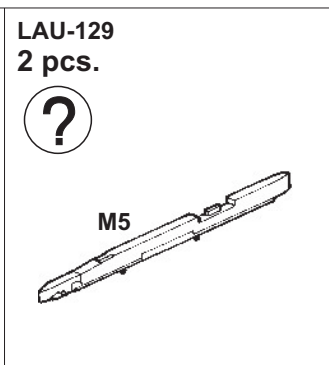
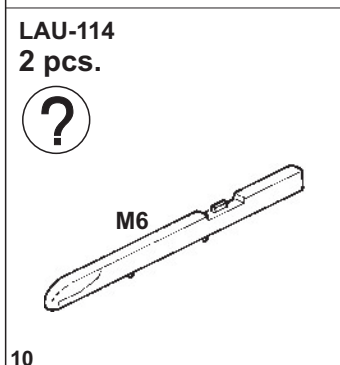
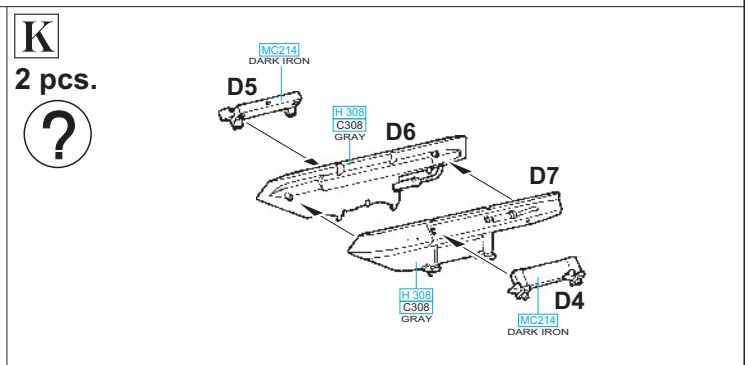
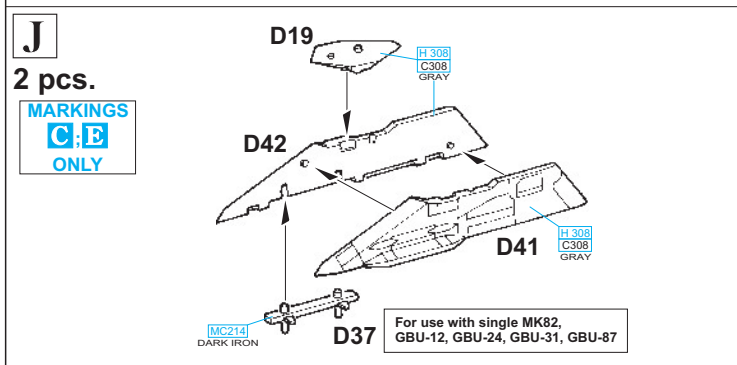
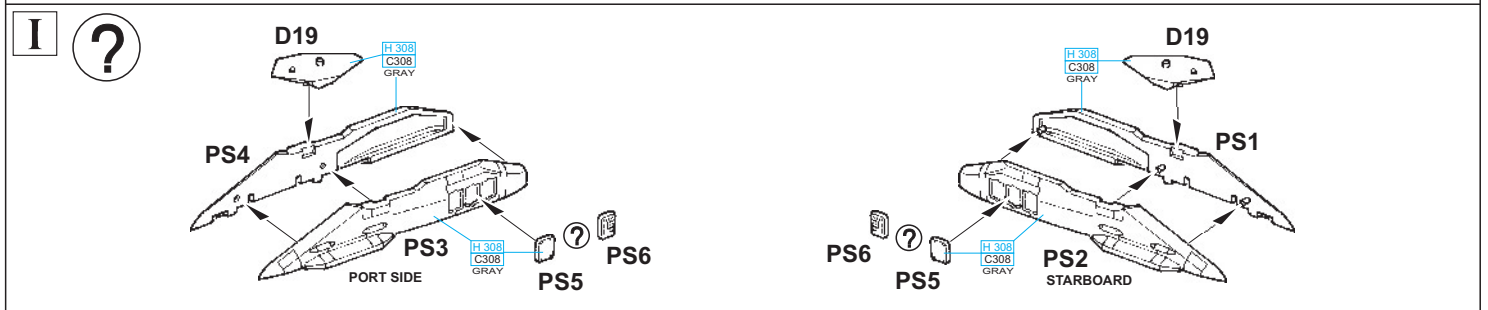
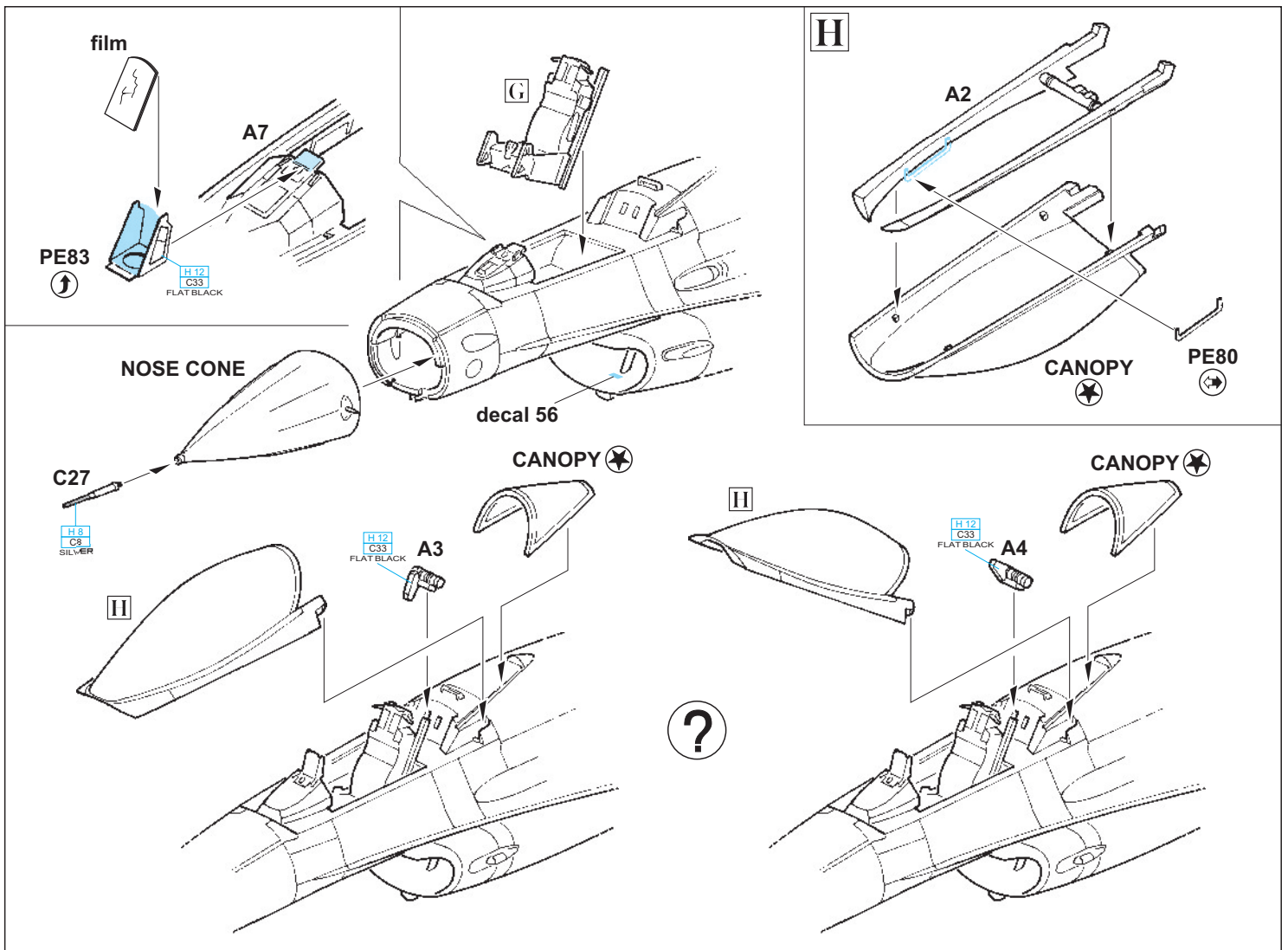

300 GALLON TANK

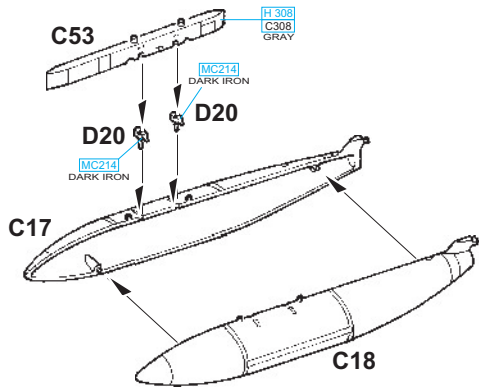

370 GALLON TANK
2 pcs.

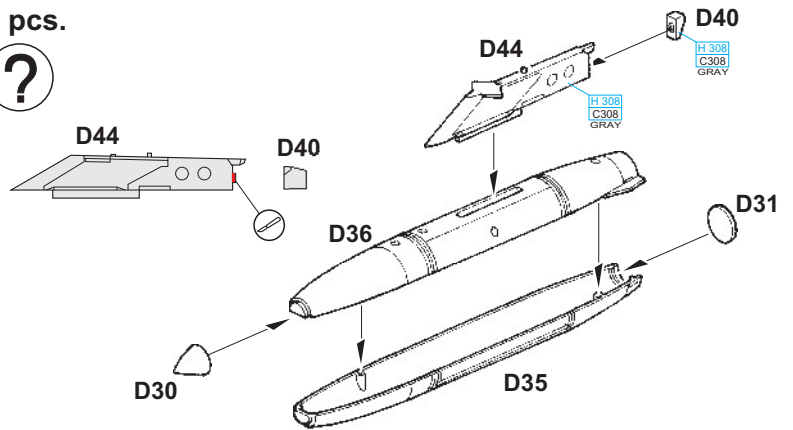

AN/AAQ-14

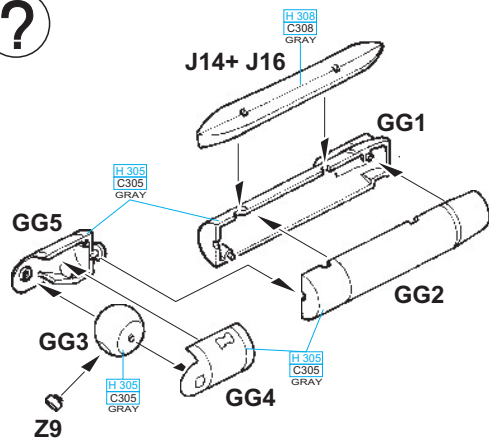

AGM-65
2 pcs.

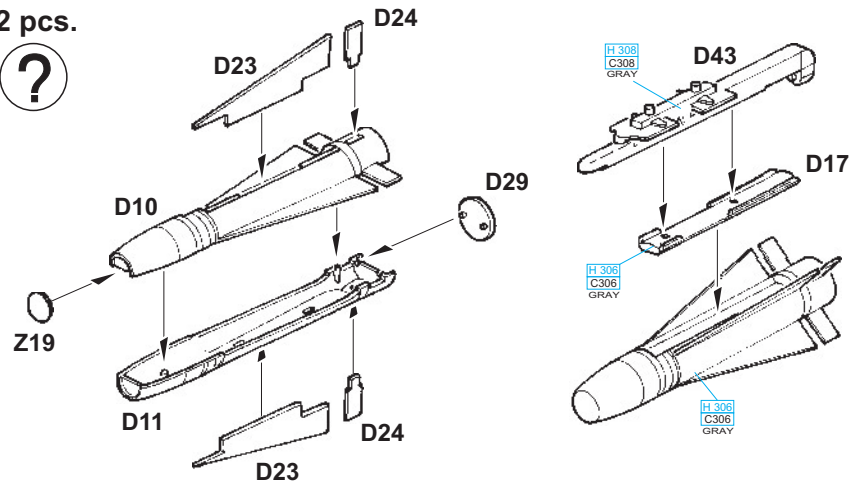

GBU-12
2 pcs.

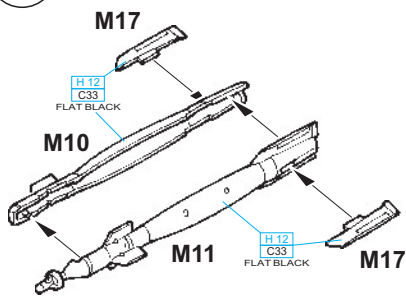

GBU-24
2 pcs.

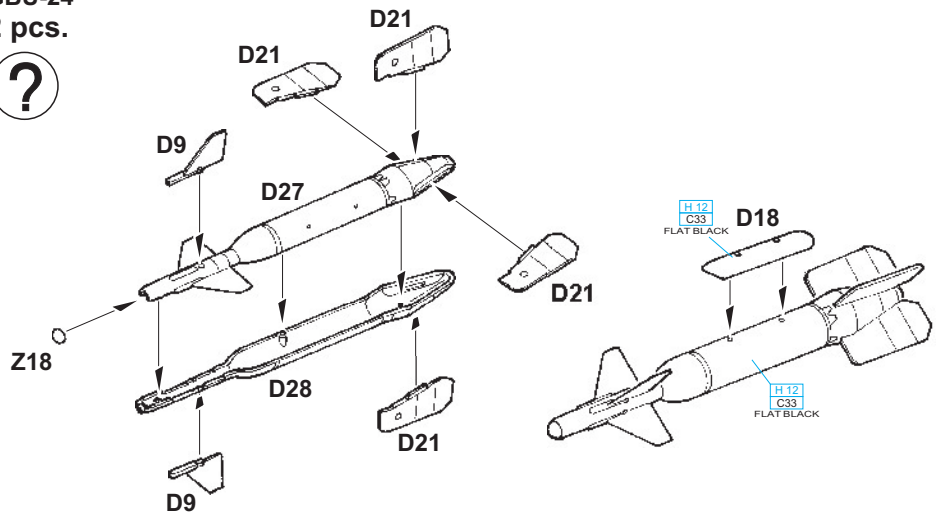

AN/ALQ-131

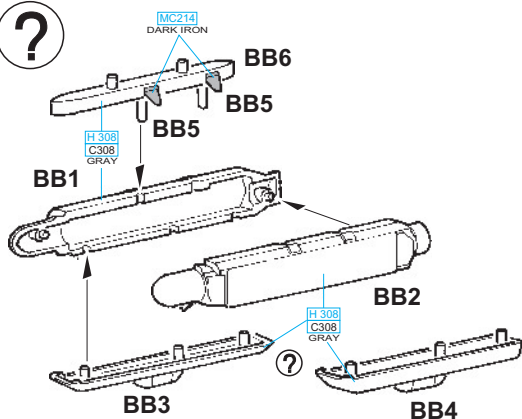

GBU-31
2 pcs.

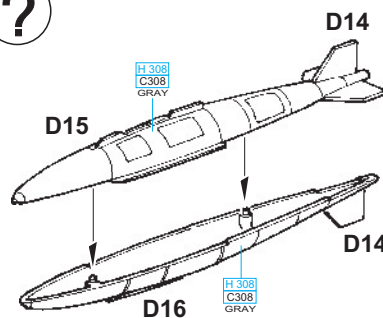

GBU-87
2 pcs.

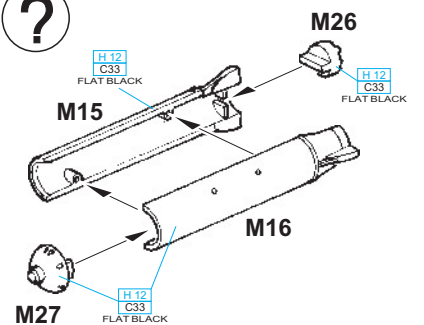

SNIPER XR

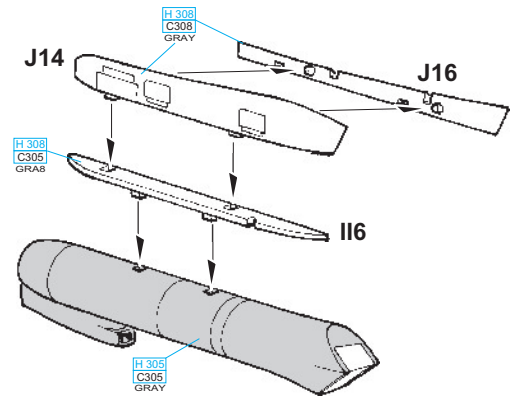
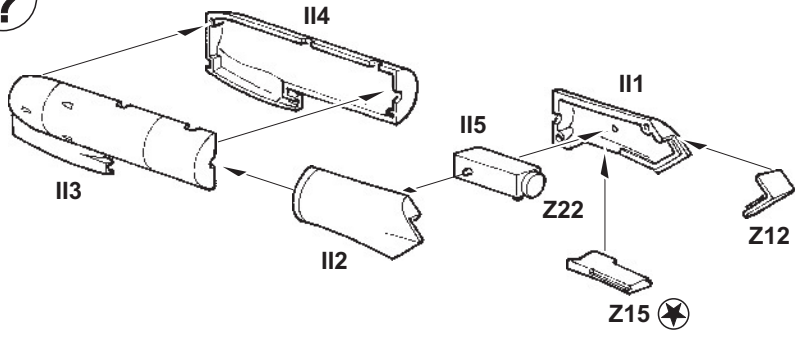

MISSION MISSILE CONFIGURATIONS
- see your reference

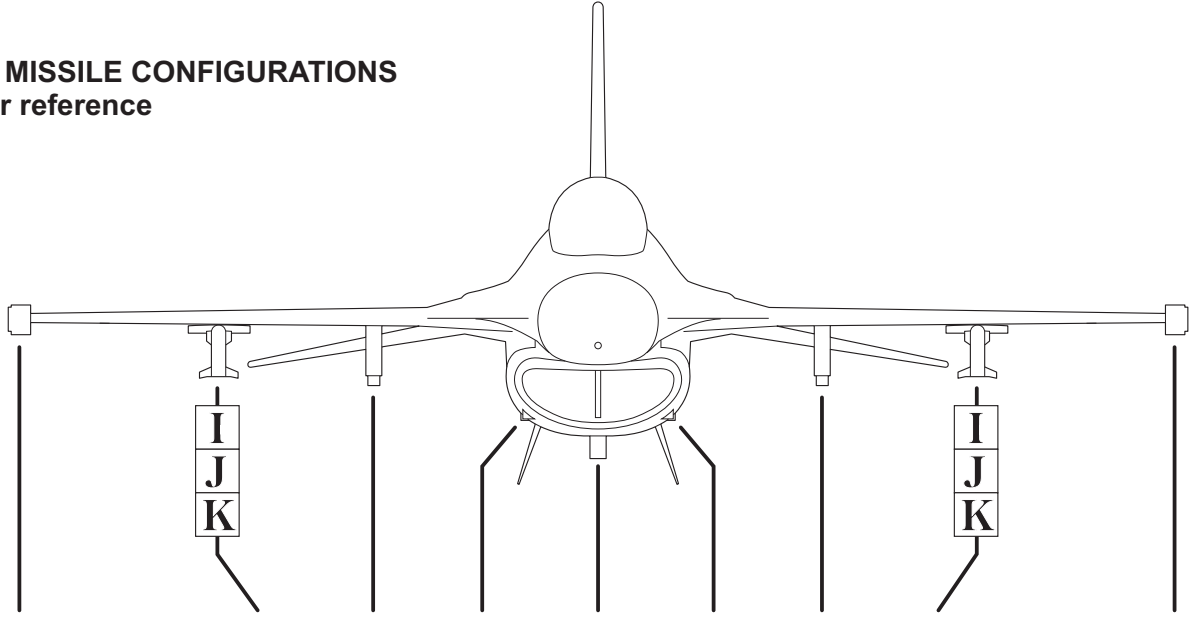

LAU-114	●										●
LAU-129	●										●
AIM-9M	●										●
AIM-120B	●										●
GBU-12			●						●		
GBU-24			●						●		
GBU-31			●						●		
GBU-87			●						●		
AGM-26			●						●		
370gal. FUEL TANK				●					●		
300gal. FUEL TANK						●					
AN/AAQ-14					●						
SNIPER XR					●						
ALQ-131							●				

A version A Block 15AM OCU, s/n 90-0943, NSAWC, NAS Fallon, 2002-2008

Falcon s/n 90-0943 was manufactured in 1992 as a part of the aircraft ordered by Pakistan. Along with other Falcons it was handed over to the U.S. Navy, and reached the Naval Strike and Air Warfare Center at NAS Fallon in 2002. The two-tone grey camouflage was replaced with a desert one. The markings of NSAWC aircraft were quite simple, consisting of the unit badge on the fin, the bort number and unit's name abbreviation on the lower fin. Through the passage of time, the color and appearance of some of the stencil data changed.

Falcon s/n 90-0943 opustil výrobní linku v roce 1992 a byl jedním ze strojů určených pro Pákistán. Stejně jako další F-16 jej po uvalení embarga převzalo americké námořnictvo. V roce 2002 se objevil ve stavu Naval Strike and Air Warfare Center na základně Fallon. Původní dvoutónový šedý kamuflážní nátěr byl nahrazen nátěrem v pouštních odstínech. Označení strojů NSAWC je poměrně prosté. Skládá se ze znaku jednotky na svislé ocasní ploše, trupového čísla a zkratky názvu jednotky na kýlové ploše pod zádi trupu.

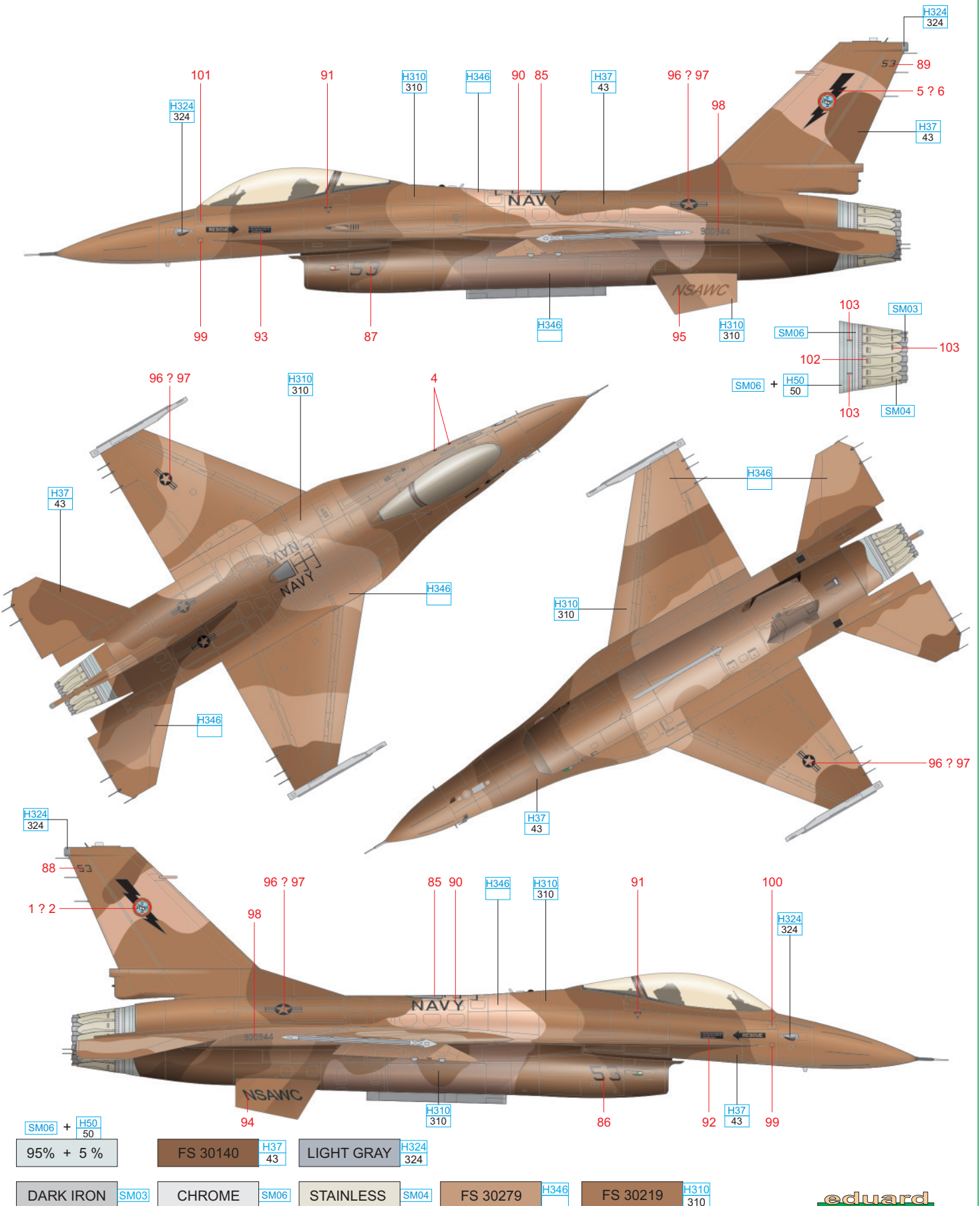

B version A Block 15AR OCU, s/n 92-0409, NSAWC, NAS Fallon, 2002 – 2008

Pakistan had ordered and paid for a total of 111 F-16A/B aircraft, but 71 of these were embargoed due to Pakistani nuclear trials that were performed. Only 28 of the embargoed aircraft were built and these were directly sent to Davis-Monthan AFB for storage. Some years later, in December 2002, nearly all of them were handed over to the Naval Strike and Air Warfare Center. This unit thanks to the popular 80's Hollywood 'Top Gun' is based in Fallon AFB, Nevada. The camouflage scheme of all three NSAWC aircraft in this boxing is of the so-called 'Aggressor scheme', and is painted on aircraft performing the aggressor role in mock combat.

Pákistán v U.S.A. objednal a zaplatit celkem 111 F-16A/B. Část byla do Asie dodána, 71 z nich však postihlo embargo na dodávky zbraní, které bylo reakcí na pákistánský jaderný program. Postaveno bylo 28 z těchto 71 objednaných strojů. Putovaly přímo k uskladnění na Davis-Monthan AFB v arizonské poušti. Zde stály řadu let, než se pro ně našlo uplatnění. V prosinci 2002 jej převzalo Naval Strike and Air Warfare Center. Tato jednotka, zvaná též po kultovním snímku Top Gun, sídlí na letecké základně Fallon v západní části Nevady.

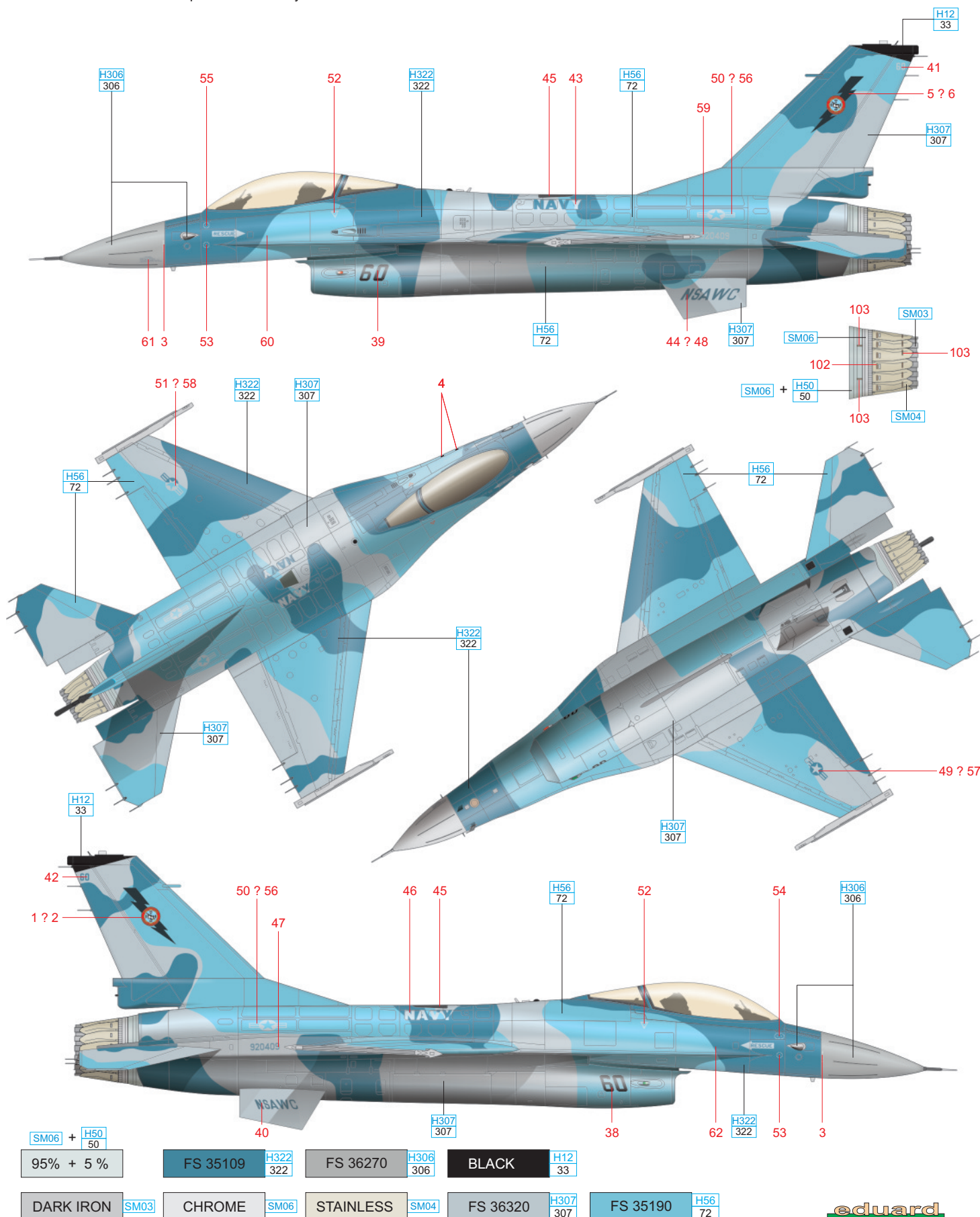

C version A Block 15AM OCU, s/n 90-0947, NSAWC, NAS Fallon, 2003-2008

The journey of this aircraft to the NSAWC was not so straight forward. It was stored in the Nevada desert till January, 2003 when it found its way to Edwards AFB, California as a part of 416th FTLS. It spent nearly two years at this Air Force Base. In November 2004, it was handed over to the NSAWC and finally ended up at NAS Fallon. The camouflage scheme was changed to the three-tone one. Photographic evidence suggests that the inscription 'NAVY' was painted on the fuselage as well as 'MARINES' later on. The camouflage colours faded with time and the whole appearance of the aircraft became interesting with the accumulation of fresh paint patches.

Zobrazený stroj měl poněkud pestřejší osud. Po uvalení embarga na vývoz do Pakistánu jej v lednu 2003 převzala 416th FTLS působící na základně Edwards v Kalifornii. K NSAWC na základnu Fallon se letoun dostal až po téměř dvou letech, v listopadu 2004. Zde dostal kamufláž složenou ze tří odstínů šedé barvy. Je fotograficky doloženo, že na hřbetě trupu nesl jak nápis NAVY, tak později též MARINES. Kamuflážní barvy postupem času bledly a opravy nátěru prováděné čerstvou barvou daly stroji zajímavý vzhled.

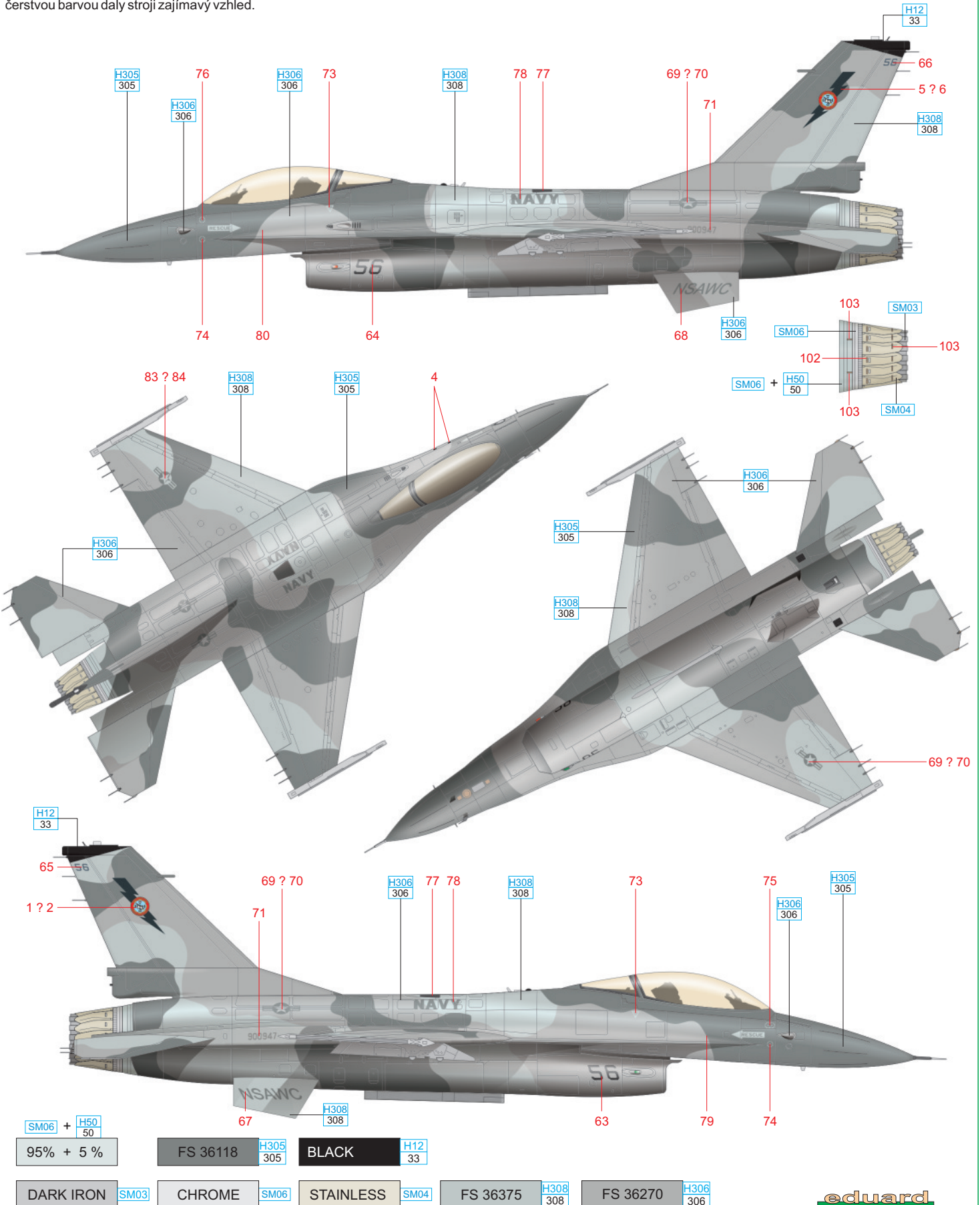

D version A Block 15C, s/n 81-0688, U.S. Air Force Flight Test Center, Edwards AFB, 1993-1995

This aircraft was flown by BrigGen Richard L. Engel, the CO of U.S. Air Force Test Center. This highly skilled pilot with more than 150 missions in Vietnam to his credit led the unit from June 1993 to July 1998. He accumulated over 4000 flying hours in the cockpit of some thirty aircraft types. This aircraft was accepted by the U.S. Navy in 1982. At that time, it wore the standard two-tone grey camouflage scheme. The exclusive white-red scheme was applied later on – during service at Edwards AFB. Note the Air Force Materiel Command on the fin. The aircraft was retired on July 13th, 1995.

S tímto letounem létal velitel U.S. Air Force Flight Test Center Brig. Gen. Richard L. Engel. Zkušený pilot se 150 misemi odlétanými ve Vietnamu velel této jednotce od června 2003 do července 1998. Za kniplem více než třech desítek typů letadel strávil přes 4000 hodin. Tento letoun si americké letectvo převzalo v roce 1982. Zpočátku létal ve standardní šedé kamufláži, atraktivní bílo-červený kabát dostal až během svého působení na Edwards ABF. Znak na kýlovce patří Air Force Materiel Command. K vyřazení stroje došlo v červenci 1995.

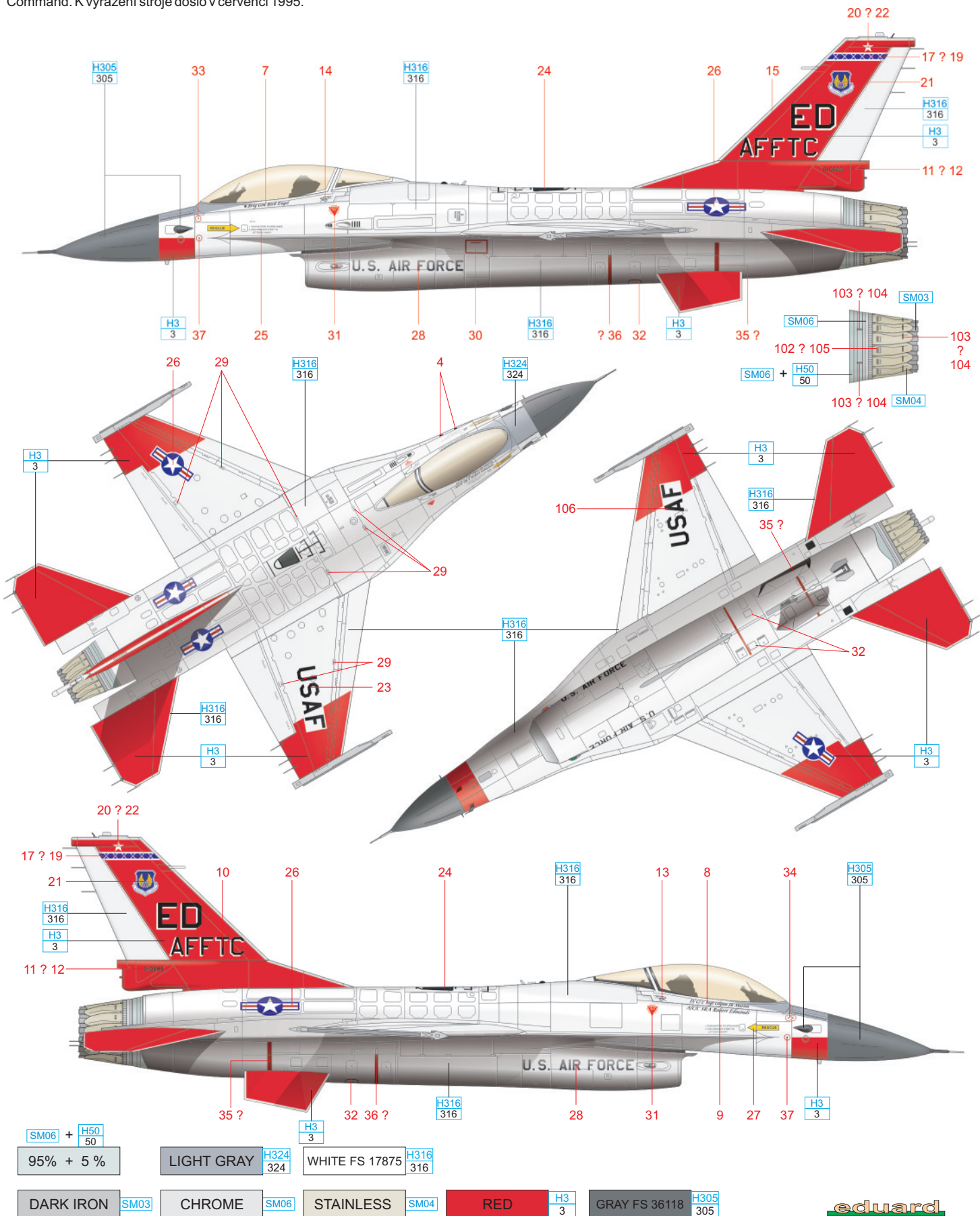

E version A Block 15AM OCU, s/n 90-0947, NSAWC, NAS Fallon, 2003-2008

The journey of this aircraft to the NSAWC was not so straight forward. It was stored in the Nevada desert till January, 2003 when it found its way to Edwards AFB, California as a part of 416th FTLS. It spent nearly two years at this Air Force Base. In November 2004, it was handed over to the NSAWC and finally ended up at NAS Fallon. The camouflage scheme was changed to the three-tone one. Photographic evidence suggests that the inscription 'NAVY' was painted on the fuselage as well as 'MARINES' later on. The camouflage colours faded with time and the whole appearance of the aircraft became interesting with the accumulation of fresh paint patches.

Zobrazený stroj měl poněkud pestřejší osud. Po uvalení embarga na vývoz do Pakistánu jej v lednu 2003 převzala 416th FTLS působící na základně Edwards v Kalifornii. K NSAWC na základnu Fallon se letoun dostal až po téměř dvou letech, v listopadu 2004. Zde dostal kamufláž složenou ze tří odstínů šedé barvy. Je fotograficky doloženo, že na hřbetě trupu nesl jak nápis NAVY, tak později též MARINES. Kamuflážní barvy postupem času bledly a opravy nátěru prováděné čerstvou barvou daly stroji zajímavý vzhled.

