

US SUPERSONIC FIGHTER 1:48 SCALE PLASTIC KIT



intro

by Brad Elward

The McDonnell Douglas F-4A Phantom II entered service with the United States Navy in December 1960, replacing both the McDonnell F3H Demon and Douglas F4D Skyray, which had served as the Navy's all-weather missile interceptors since the mid-1950s. The F-4B was the second in the Phantom II series and featured the more powerful General Electric J79-GE-8 engines (16,950-lb/75.4kN thrust), a raised and enlarged cockpit to allow the backseater better visibility, and a more bulbous nose section to accommodate the Westinghouse APQ-72 radar.

The F-4B possessed a top speed in excess of Mach 2.2 and set many performance records in the late 1950s. It could carry up to 18,000 lbs of ordnance on nine external weapons stations. Four stations were located on the wings, referred to as inner and outer stations, which could carry external fuel tanks (inner stations only), bombs, or missiles. A centerline station typically carried an external fuel tank although it could, but rarely did carry the Mk-4 20 mm gun pod. Four additional stations were recessed on the aircraft's lower fuselage to house the radar-guided AIM-7 Sparrow III missile. Unlike other fighter aircraft of the day, the F-4B did not have a gun, but relied on its long-range missiles for defense. Most missions saw the F-4B armed with at least two AIM-9 infrared Sidewinders and two Sparrow IIIs.

The Phantom II was crewed by a pilot and a Radar Intercept Officer (RIO – Navy) or Weapon System Officer (WSO – Marines). The RIO/WSO in the aft cockpit assisted with navigation, communication, and operated the long-range APQ-72 radar. The RIO/WSO proved extremely valuable in combat, providing a second set of eyes for locating enemy aircraft or surface-to-air missiles (SAMs).

F-4Bs began entering U.S. Navy fleet service in July 1961 with VF-74 Bedevilers, an Atlantic Fleet fighter squadron based at NAS Oceana, Virginia, and shortly thereafter by VF-114 Aardvarks, a Pacific based squadron at NAS Miramar, California. The Phantom II was used extensively during the Vietnam War by all three United States air services as a fighter-bomber. However, the F-4B was used solely by the U.S. Navy and U.S. Marine Corps. When U.S. involvement in the war began in August 1965, 13 of the Navy's 31 fleet fighter squadrons had already transitioned to the F-4B. Indeed, two F-4B squadrons, VFA-142 Ghost Riders and VFA-143 Pukin' Dogs, were deployed aboard USS Constellation with Carrier Air Wing 14 and took part in the opening U.S. air strikes against North Vietnam as part of Operation Pierce Arrow, which retaliated for the attacks against U.S. surface ships in the Tonkin Gulf. The Navy made a total of 51 F-4B squadron deployments during the war, with the F-4B accounting for 22 of the service's MiG kills and two An-2 kills. Five F-4Bs were lost in air-to-air combat.

The Marine Corps also operated the F-4B, taking initial deliveries of the aircraft in late 1962. VMFA-531 Gray Ghosts were the first to fly the Phantom II and eventually took the F-4B to Vietnam. F-4B's of Marine Air Group (MAG) 11 flew ground support missions out of Da Nang and Nam Phong, South Vietnam, while MAG-13 operated out of Chu Lai. Twelve USMC squadrons flew the F-4B, eight of which served in Vietnam at some point during the war. The USMC also operated a tactical reconnaissance version designated as the RF-4B, which served into the late 1980s with VMCJ and VMFP squadrons.

Although designed as an interceptor, F-4Bs served well in air-to-ground and fighter roles, flying close air support (CAS), flak suppression, MiG Combat Air Patrol (MIGCAP), Barrier CAP (BARCAP), and Target CAP (TARCAP) missions. The latter three missions protected strike packages against North Vietnamese MiG attacks. Marine F-4Bs flew more air-to-ground missions.

A total of 649 F-4Bs were built by McDonnell Douglas in St. Louis, Missouri, during a production run lasting from mid-1961 through the end of 1966, when it began being replaced by the improved F-4J.

DECALS AND COLOR PROFILES DESIGNED BY

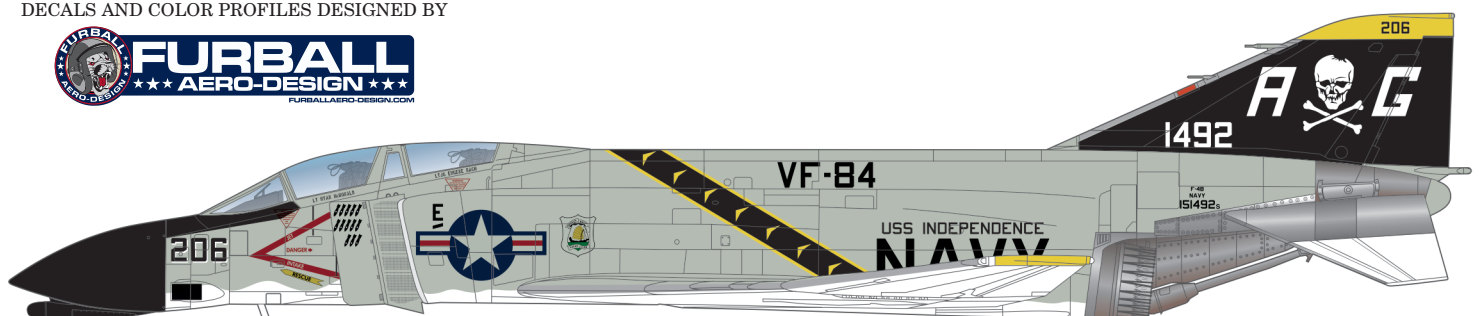

ATTENTION



UPOZORNĚNÍ



ACHTUNG



ATTENTION



注意



Carefully read instruction sheet before assembling. When you use glue or paint, do not use near open flame and use in well ventilated room. Keep out of reach of small children. Children must not be allowed to suck any part, or pull vinyl bag over the head.



Před započítím stavby si pečlivě prostudujte stavební návod. Při používání barev a lepidel pracujte v dobře větrané místnosti. Lepidla ani barvy nepoužívejte v blízkosti otevřeného ohně. Model není určen malým dětem, mohlo by dojít k požití drobných dílů.

INSTRUCTION SIGNS * INSTR. SYMBOLS * INSTRUKTION SINNBILDEN * SIMBOLES * 記号の説明

OPTIONAL
VOLBABEND
OHNOUTOPEN HOLE
VYVRTAT OTVORSYMMETRICAL ASSEMBLY
SYMETRICKÁ MONTÁŽREMOVE
ODŘÍZNOUTREVERSE SIDE
OTOČITAPPLY EDUARD MASK
AND PAINT
POUŽIT EDUARD MASK
NABARVIT

PARTS



DÍLY



TEILE



PIÈCES



部品

B>

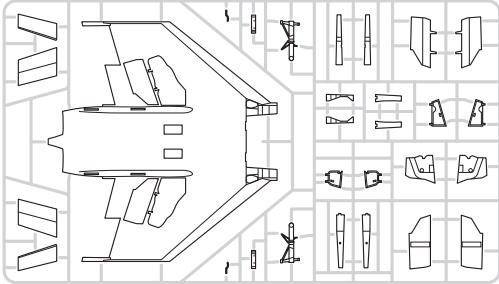

E>

PLASTIC PARTS

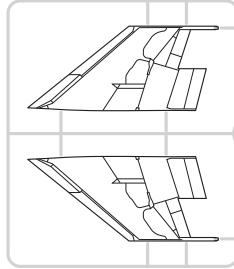

F>

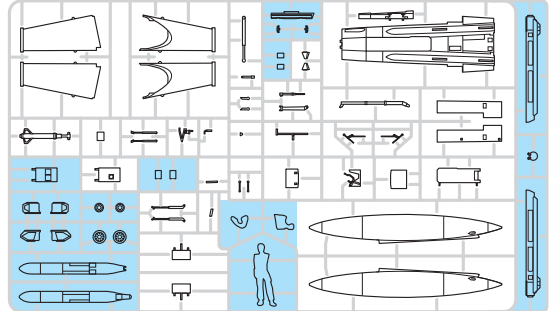

G>

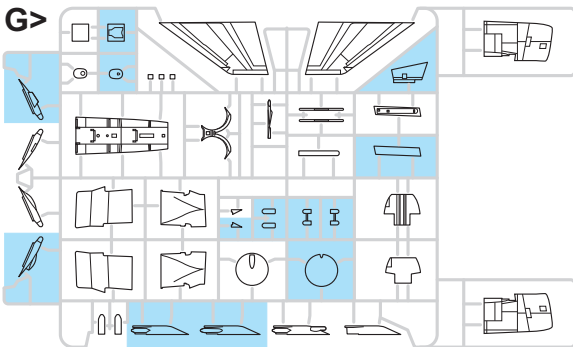

H>

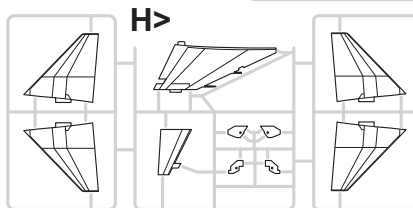

I>

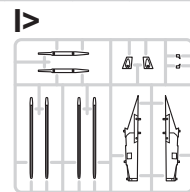

K>

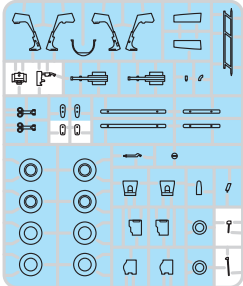

O>

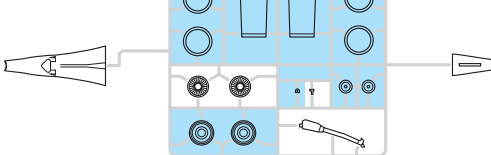

L>

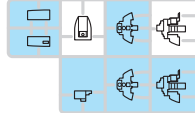

R>

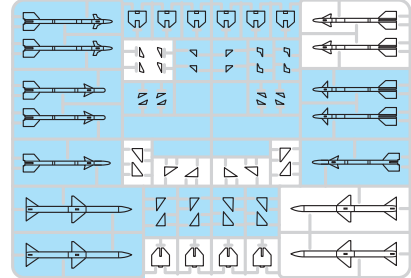

P> 2 pcs.

Upper
Fuselage

Q> 2 pcs.

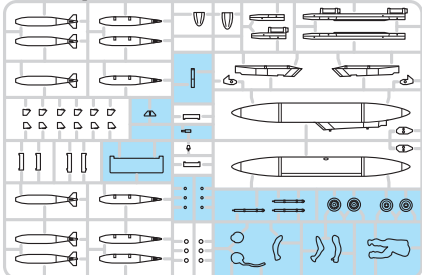
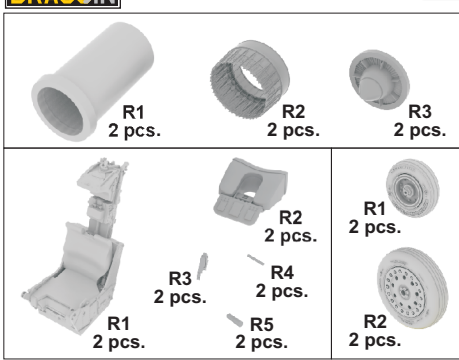
eduard
BRASSIN RP - RESIN PARTS

PE - PHOTO ETCHED DETAIL PARTS

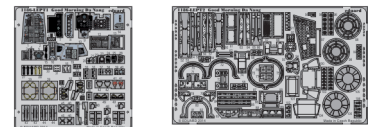

FILM

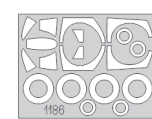
eduard
MASKTP - TEXTILE
PARTS

-Parts not for use. -Teile werden nicht verwendet. -Pièces à ne pas utiliser. -Tyto díly nepoužívejte při stavbě. - 使用しない部品

COLOURS



BARVY



FARBEN



PEINTURE



色

GSi Creos (GUNZE)		
AQUEOUS	Mr.COLOR	
H 2	C 2	BLACK
H 3	C 3	RED
H 8	C 8	SILVER
H 12	C 33	FLAT BLACK

AQUEOUS	Mr.COLOR	
H 13		FLAT RED
H 77	C 137	TIRE BLACK
H 304	C 304	OLIVE DRAB
H 316	C 316	WHITE
H 317	C 317	GRAY

AQUEOUS	Mr.COLOR	
H 325	C 325	GRAY
H 329	C 329	YELLOW
Mr.METAL COLOR		
MC 213		STAINLESS
MC 214		DARK IRON

A

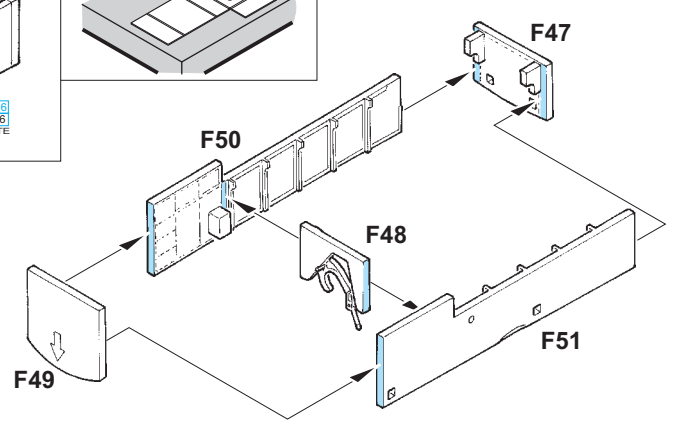
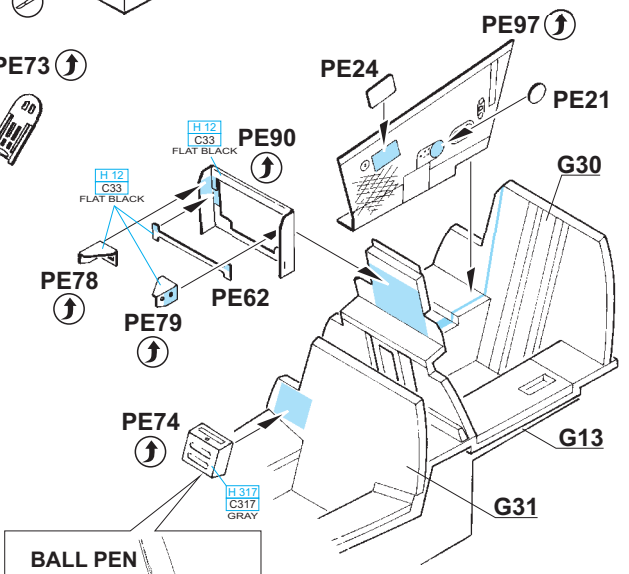
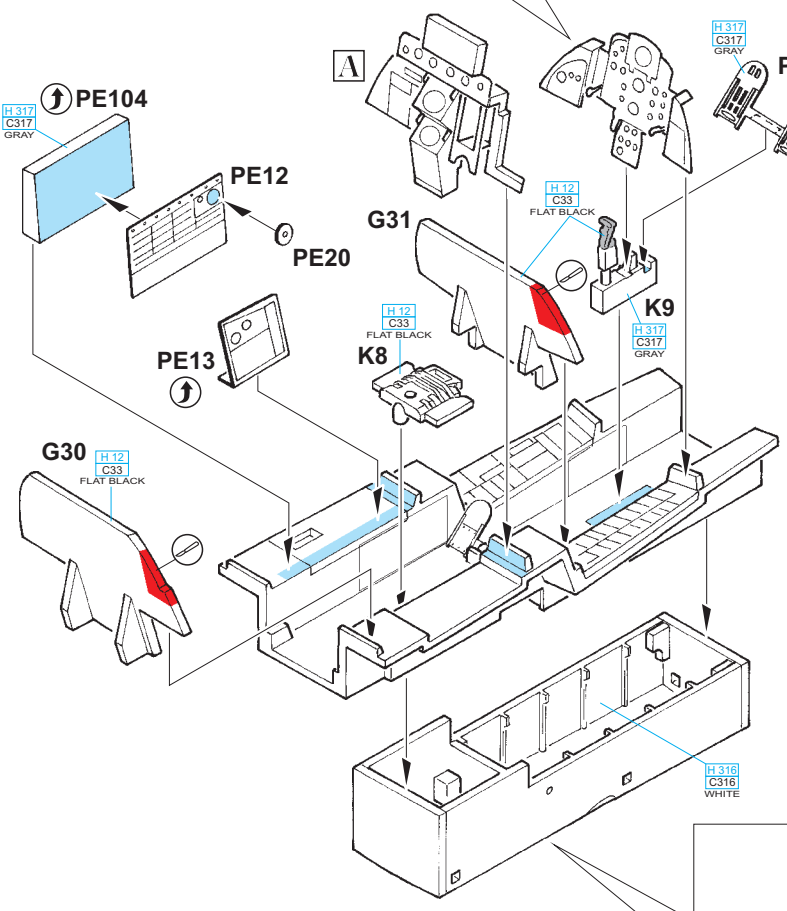
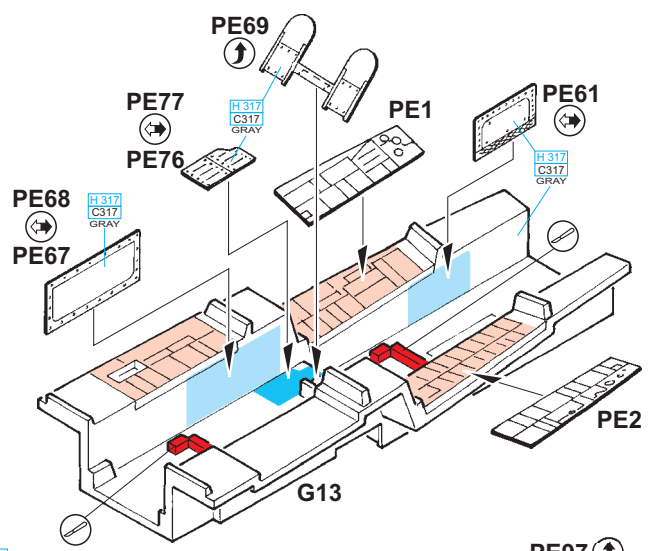
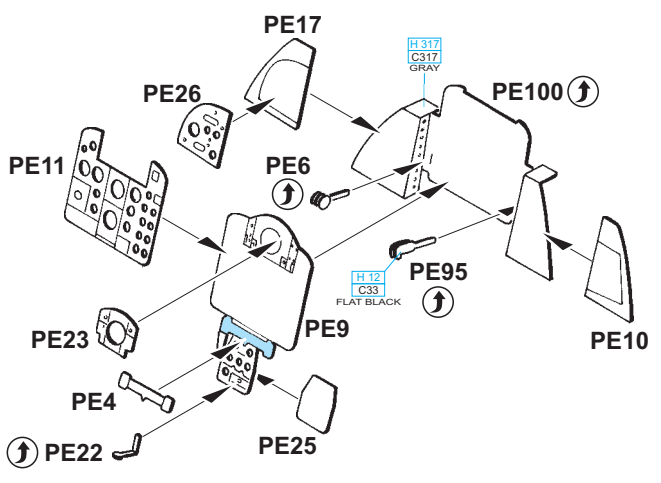
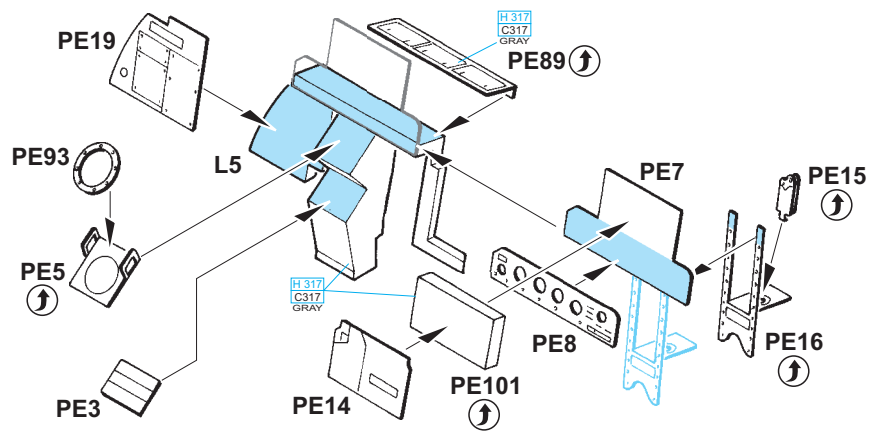
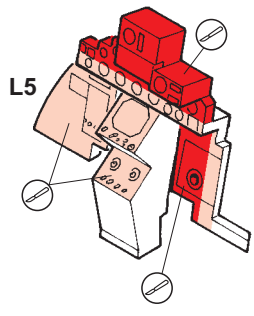

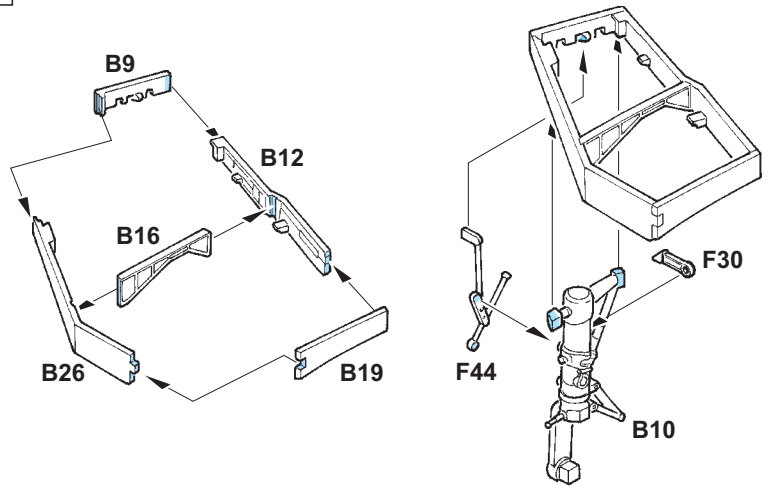
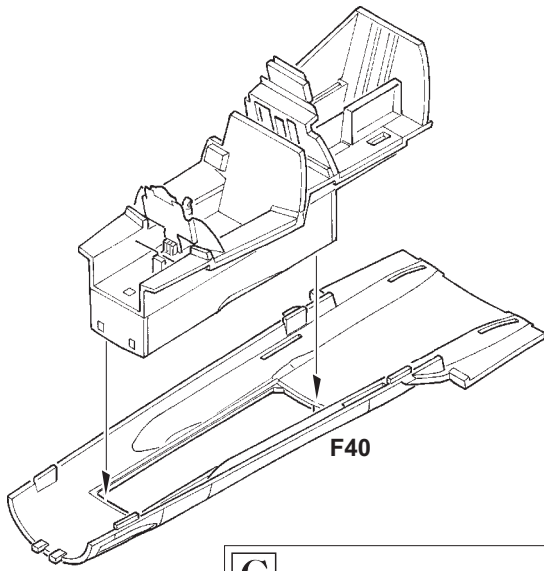
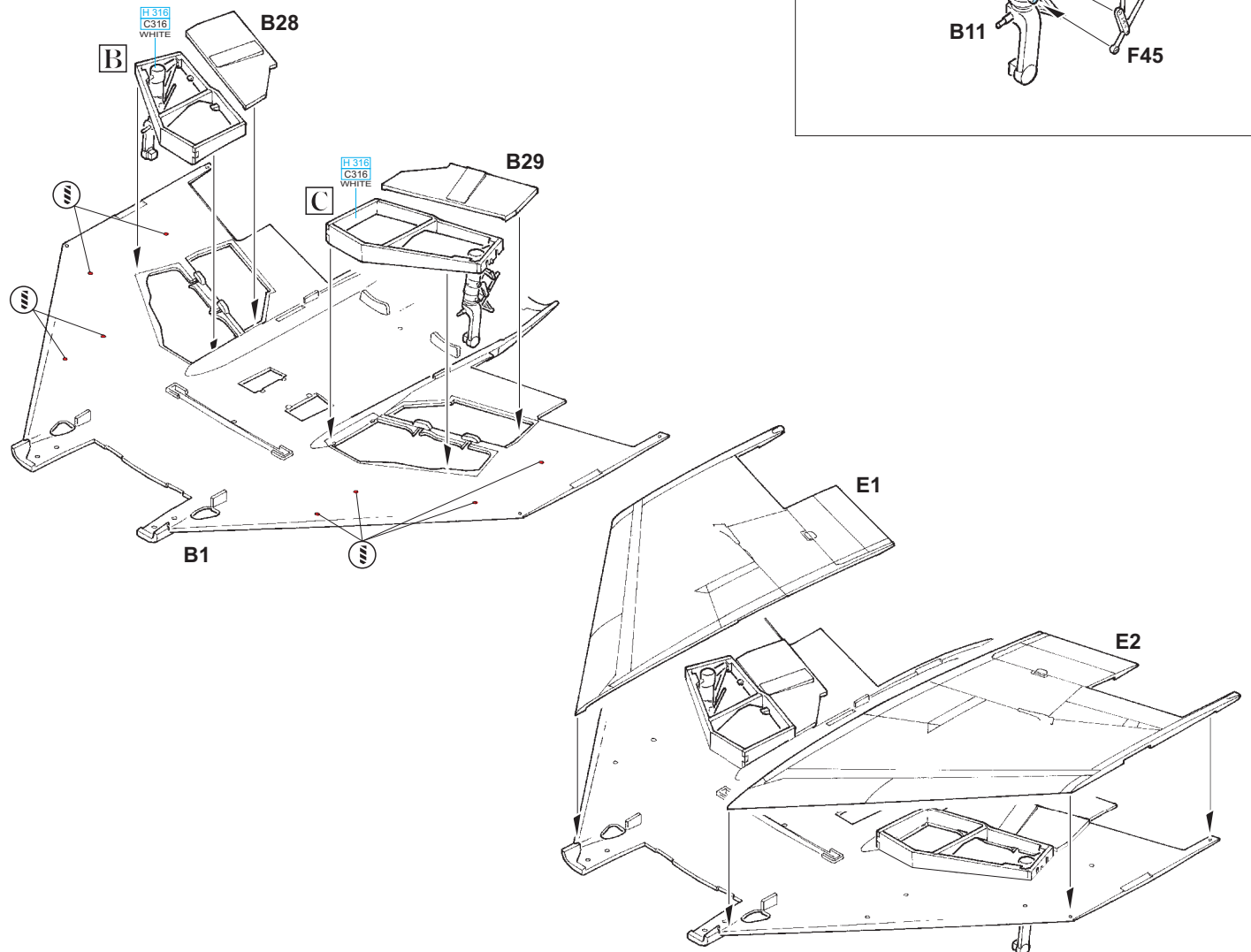
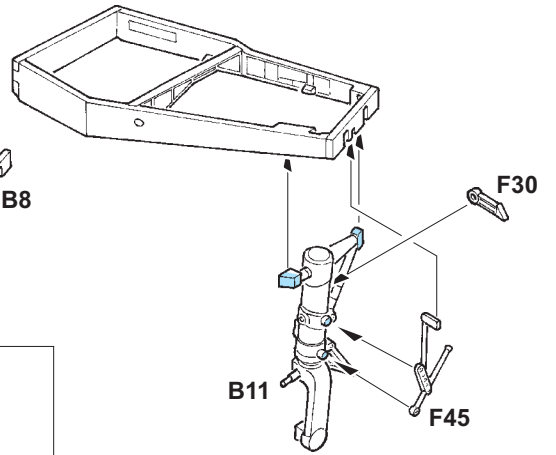
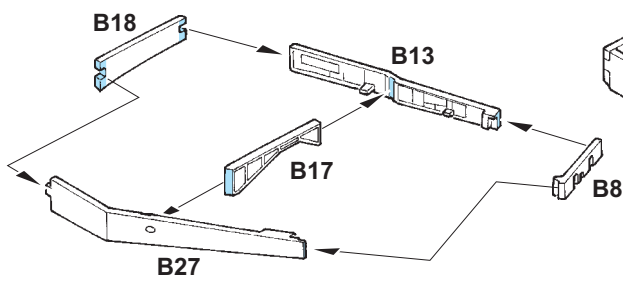
B**C**

D 2 pcs.

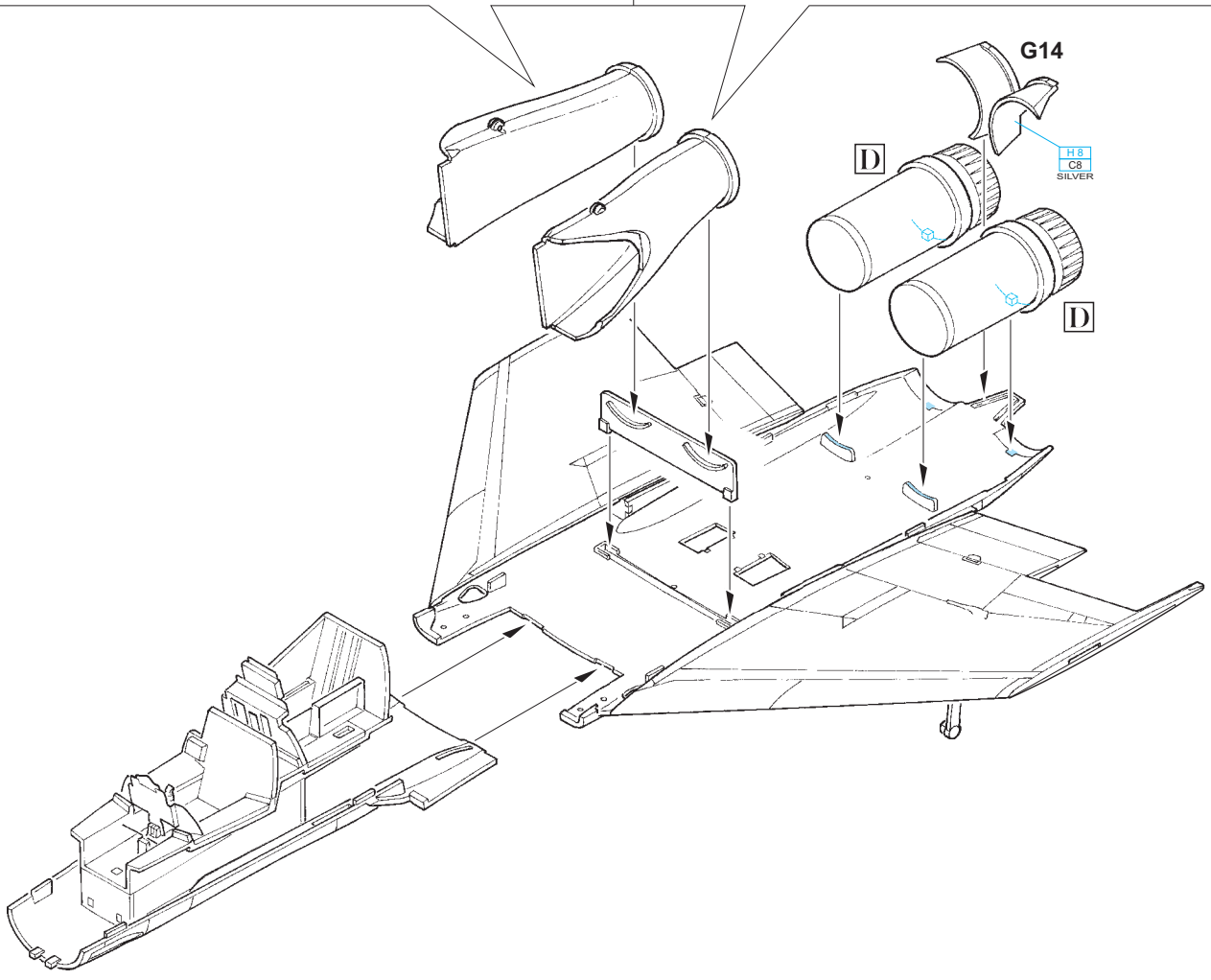
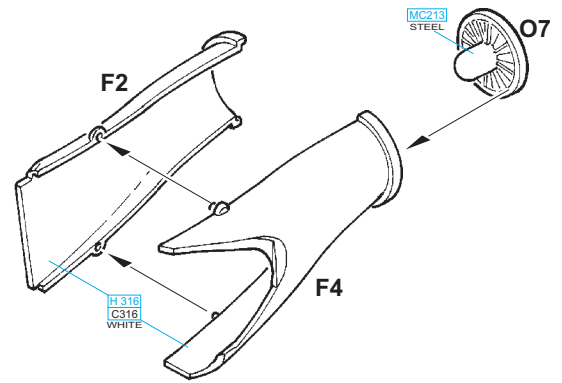
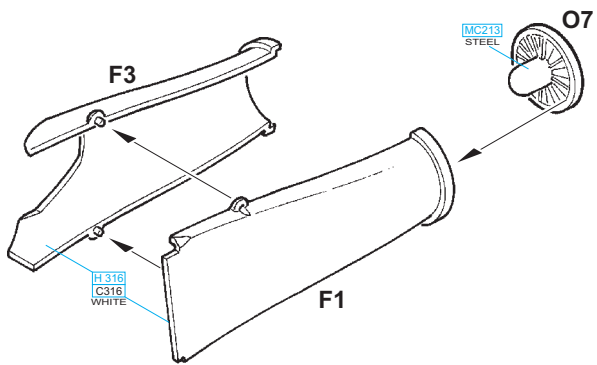
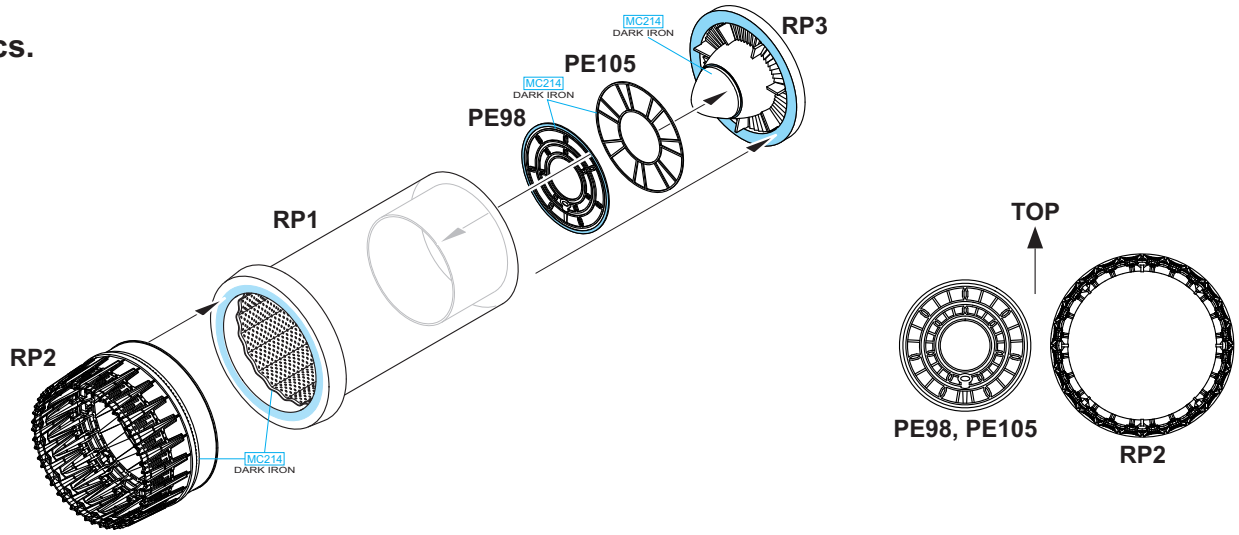

Upper Fuselage

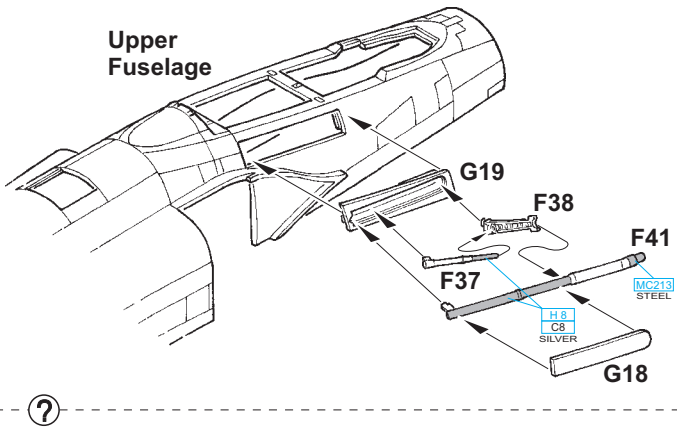

Upper Fuselage

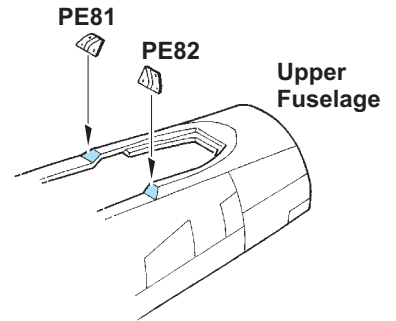
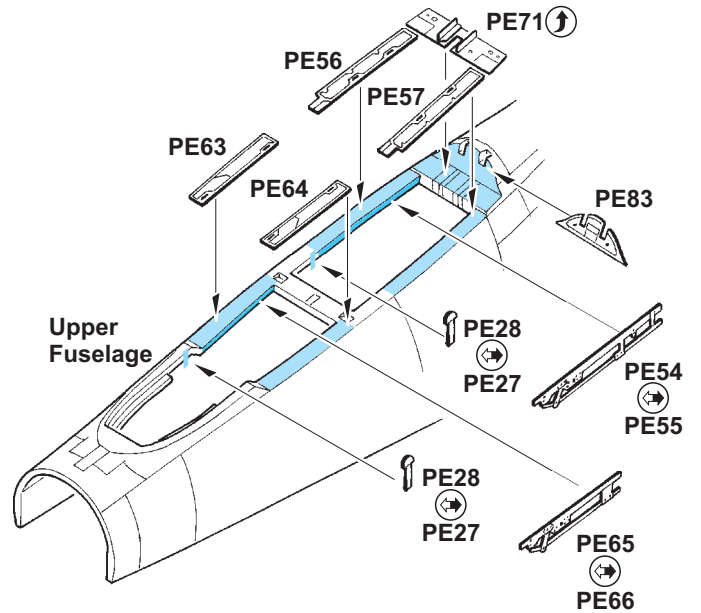
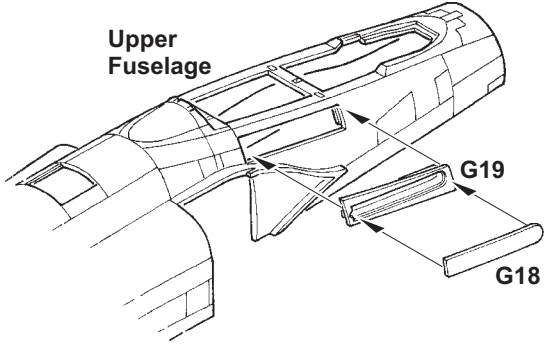

Upper Fuselage

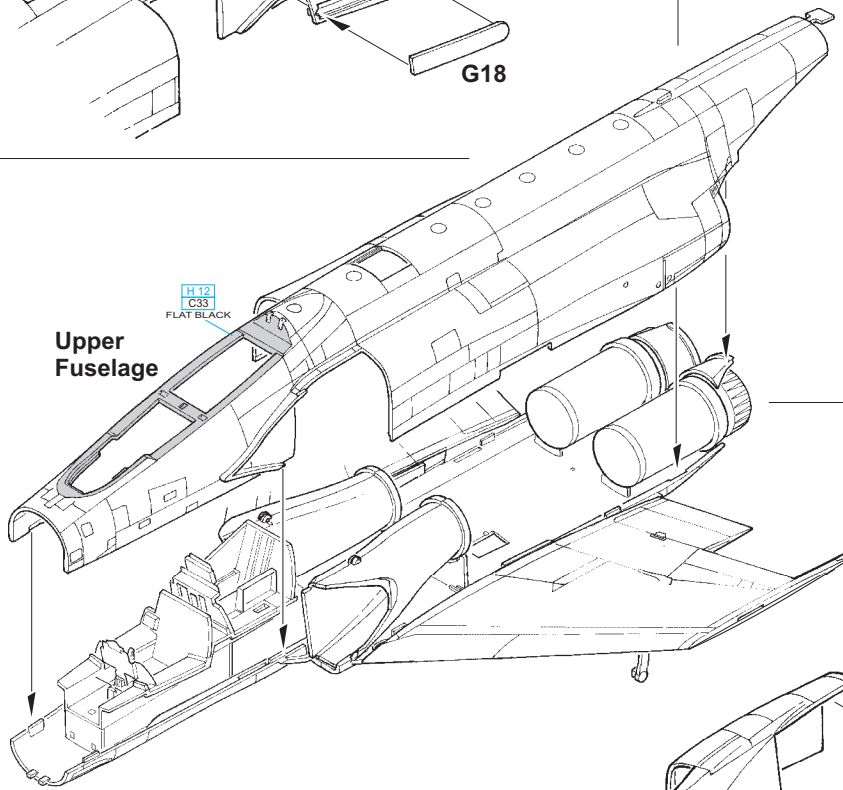

G40

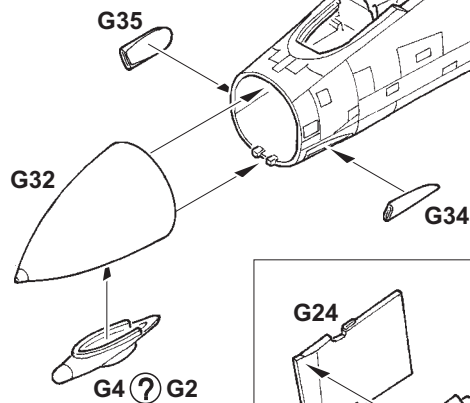
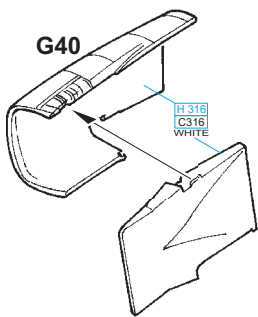

G4 - MARKING **B** ONLY

G21

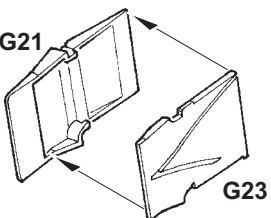

G24

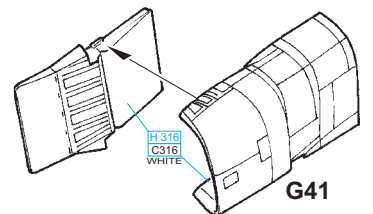
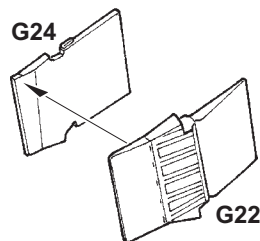

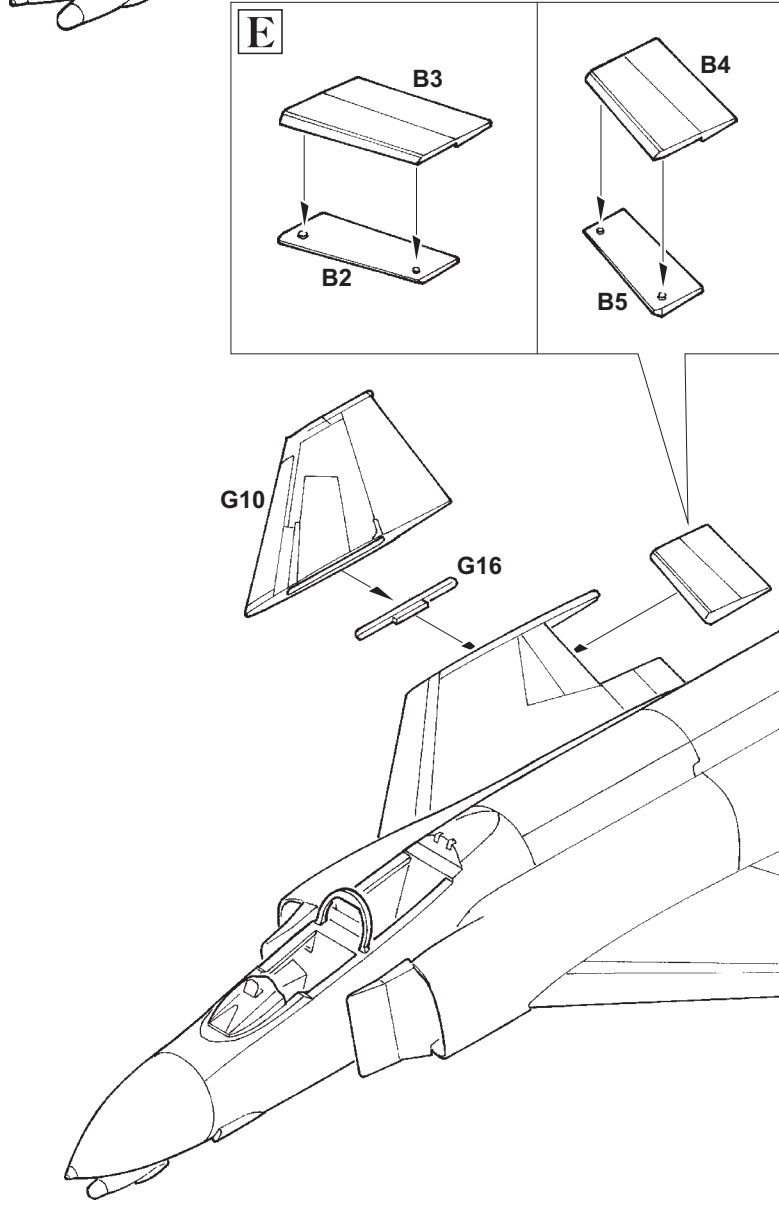
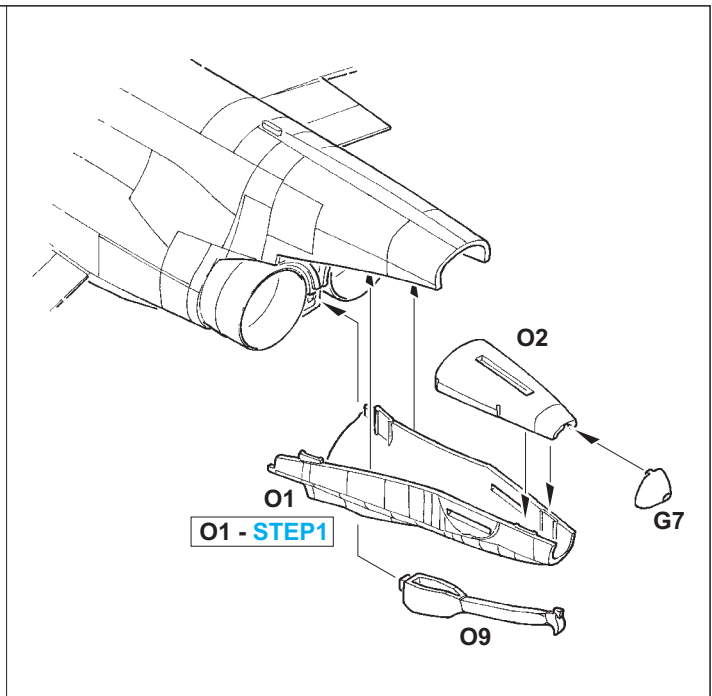
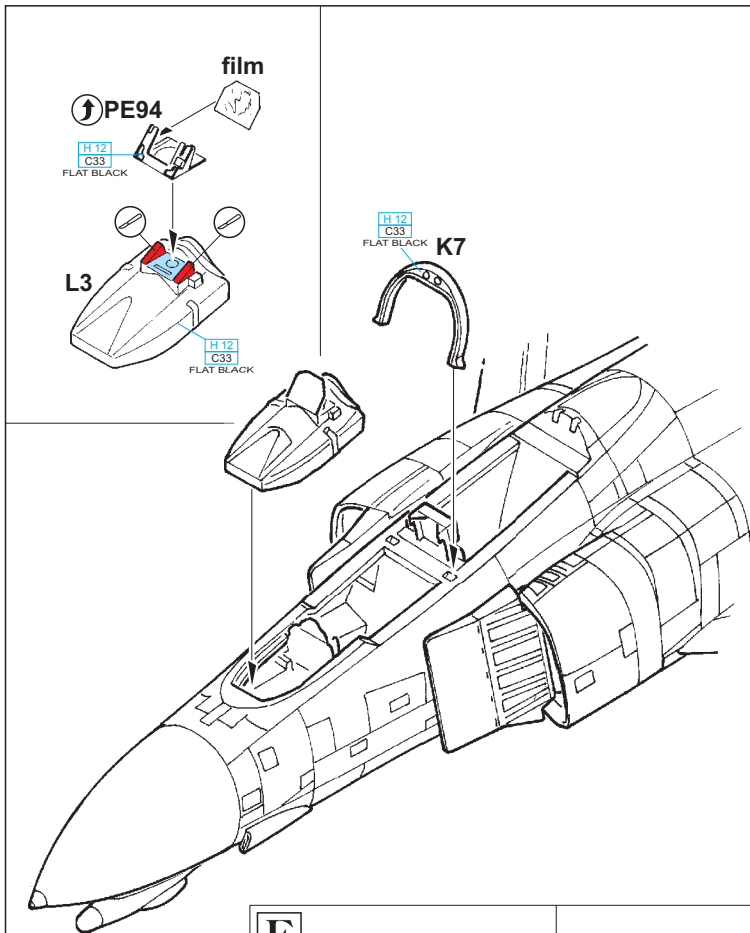

G38 - MARKINGS D, E
 G39 - MARKINGS A, B, C

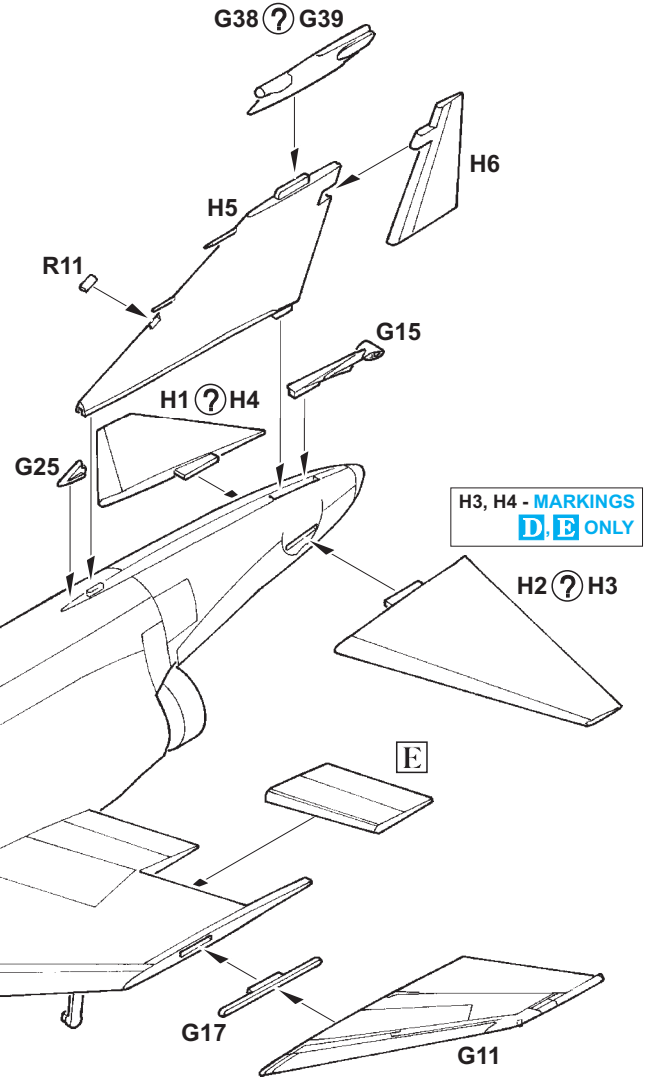

H3, H4 - MARKINGS D, E ONLY

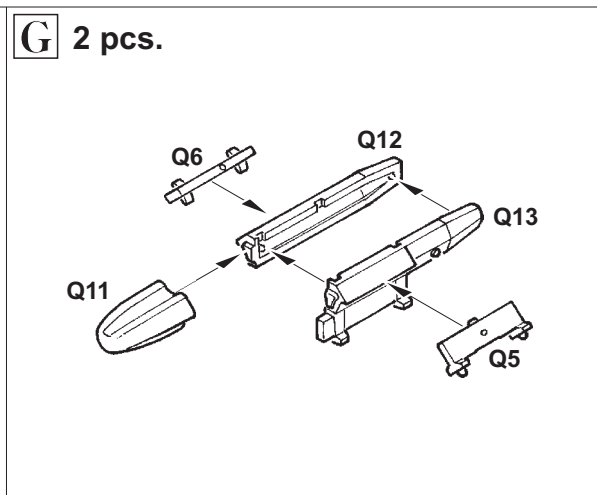
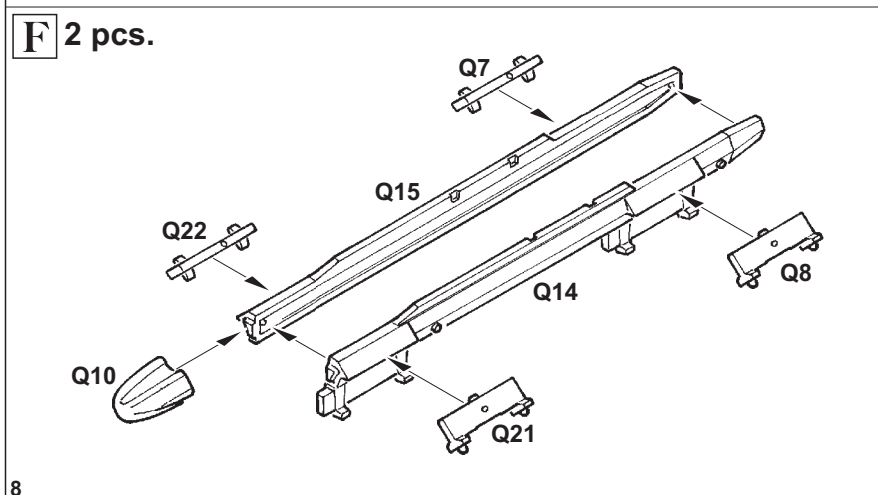
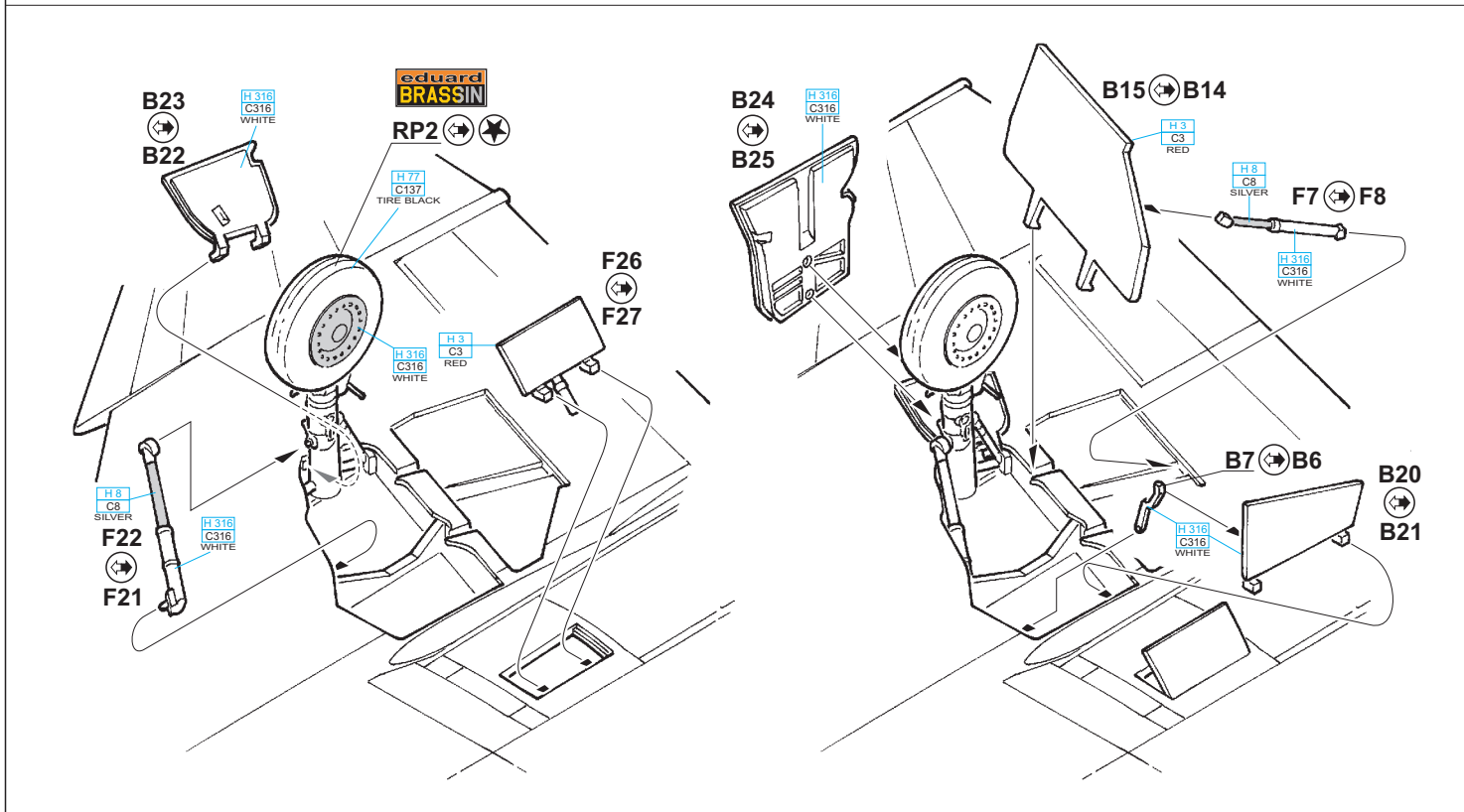
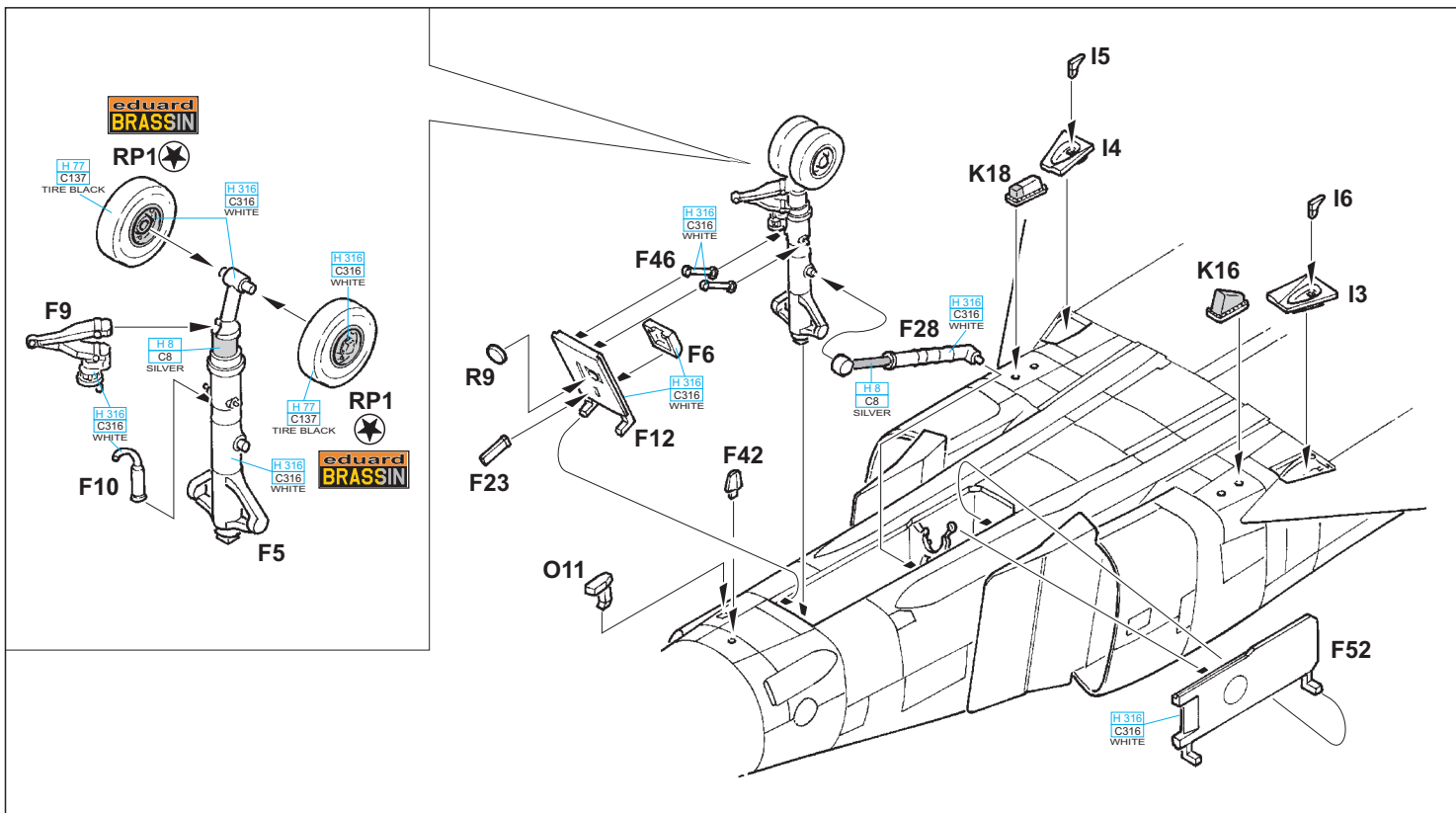

H Pylon 1

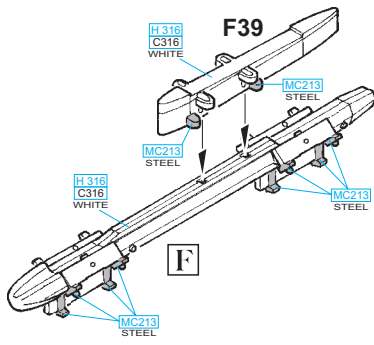

J Pylon 2 Right

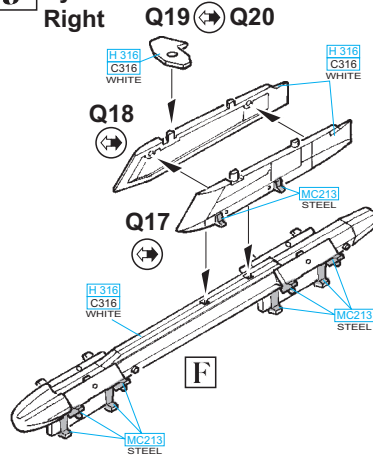

K Pylon 3 Right

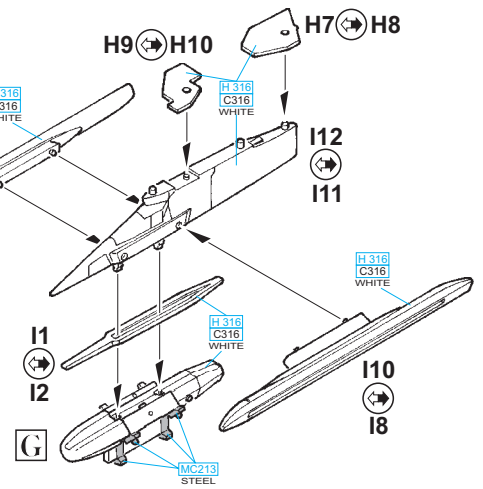

4 pcs.

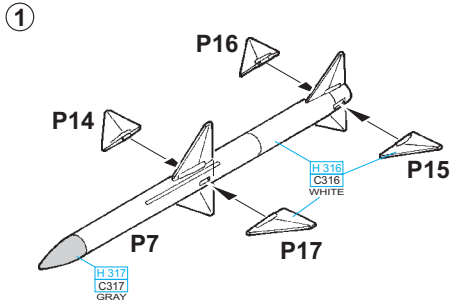

4 pcs.

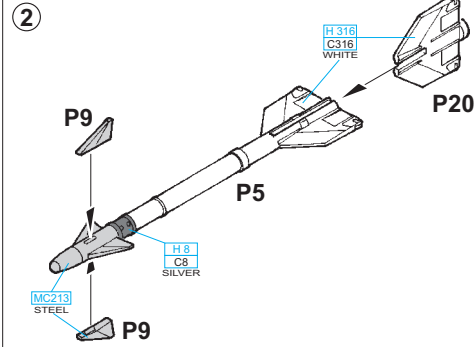

12 pcs.

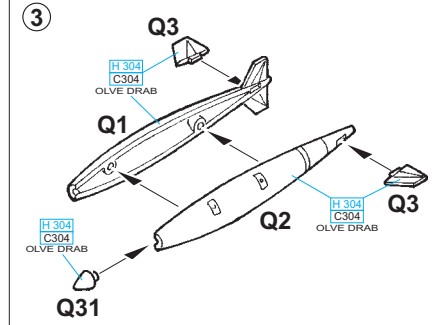

Fuel tank Right

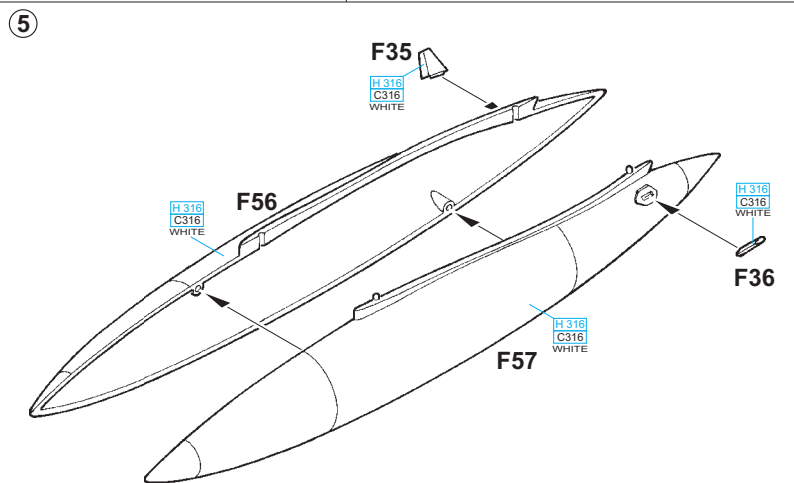
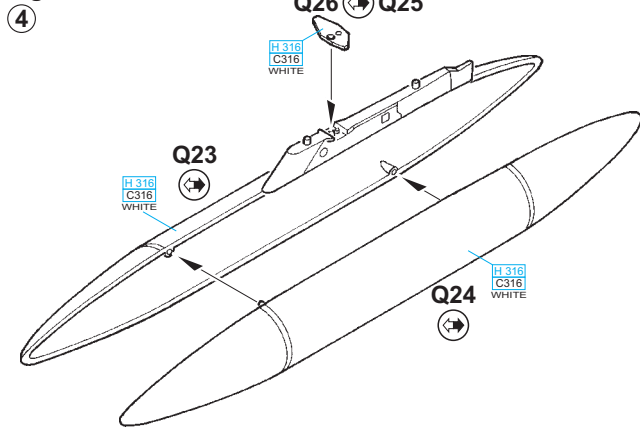

eduard
MASK

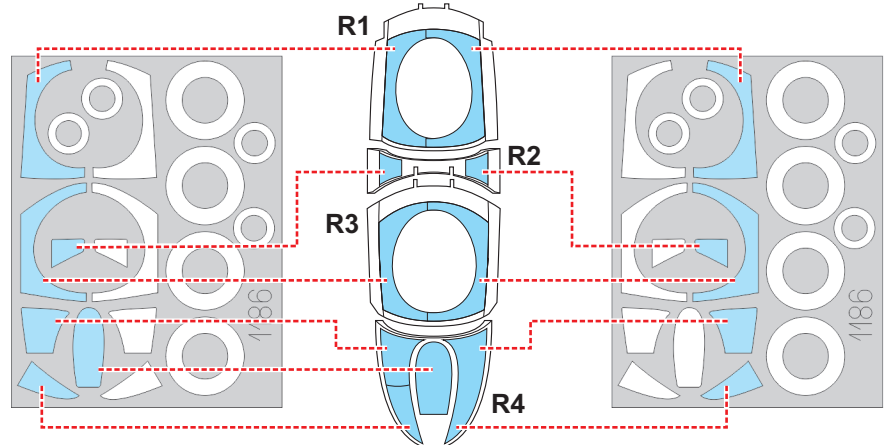
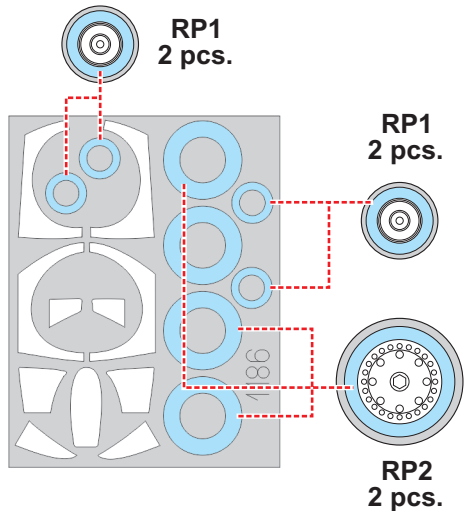

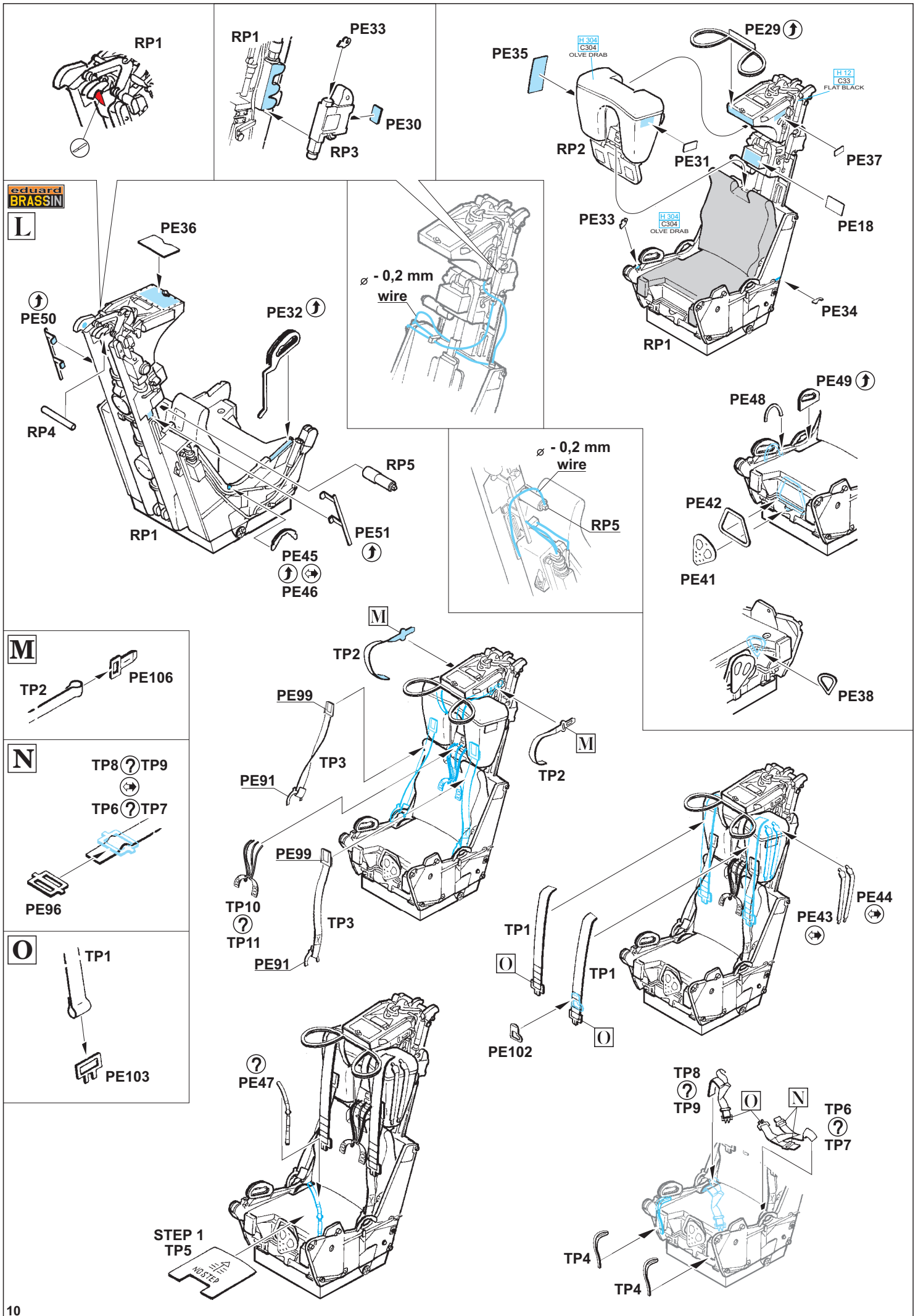

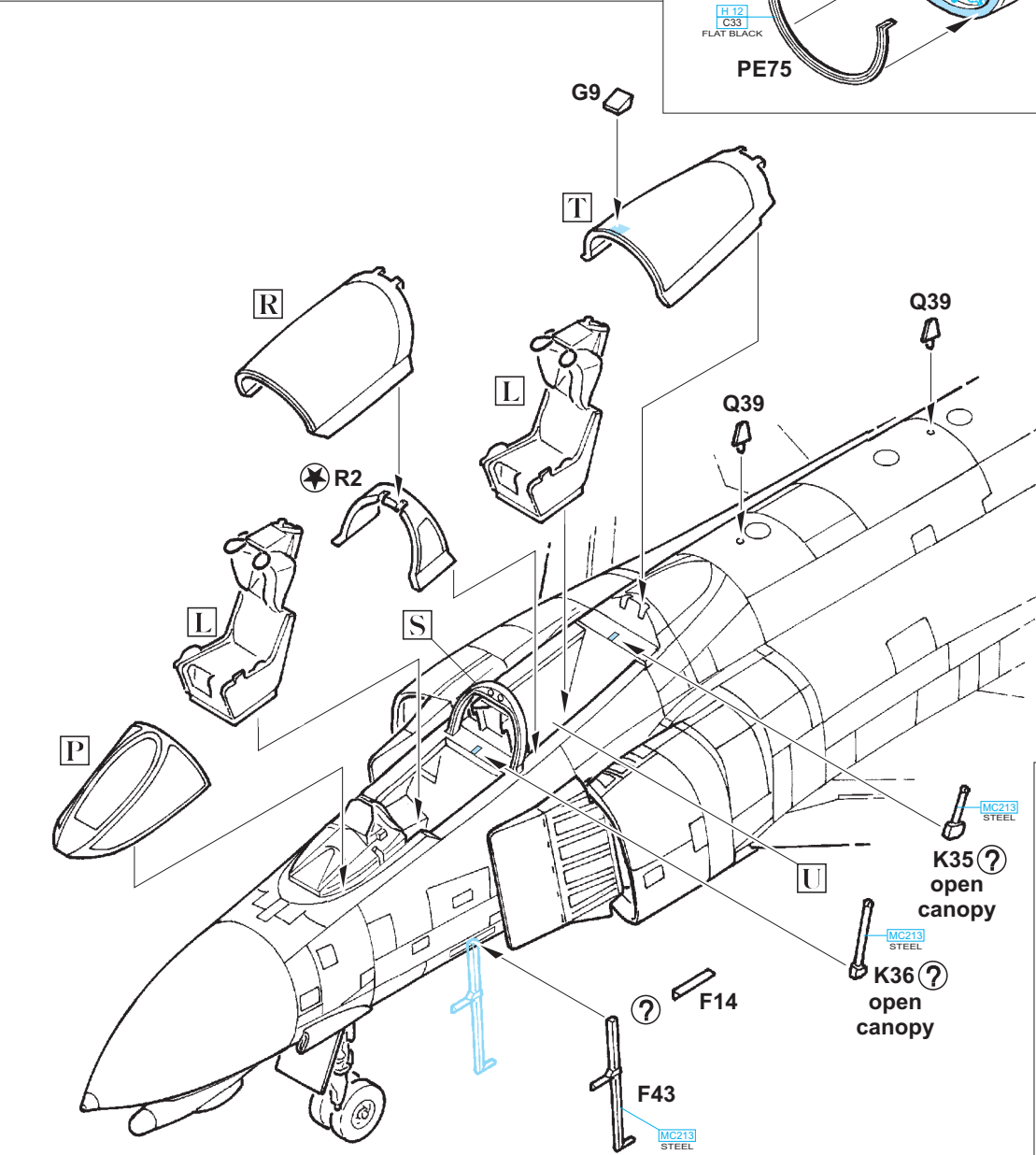
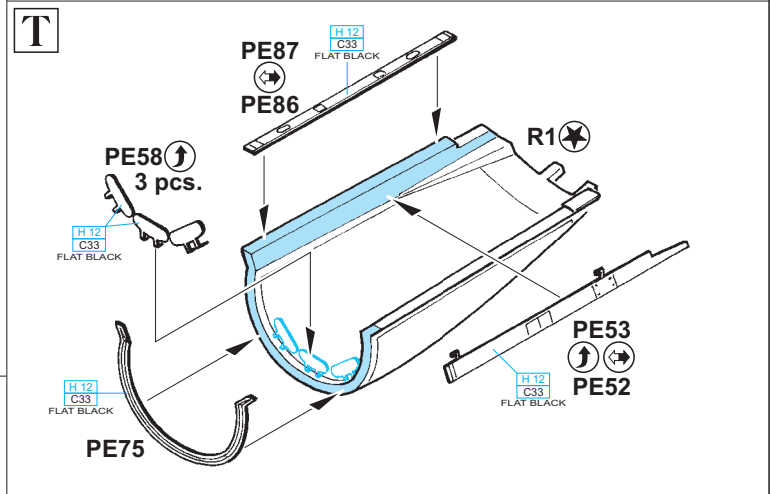
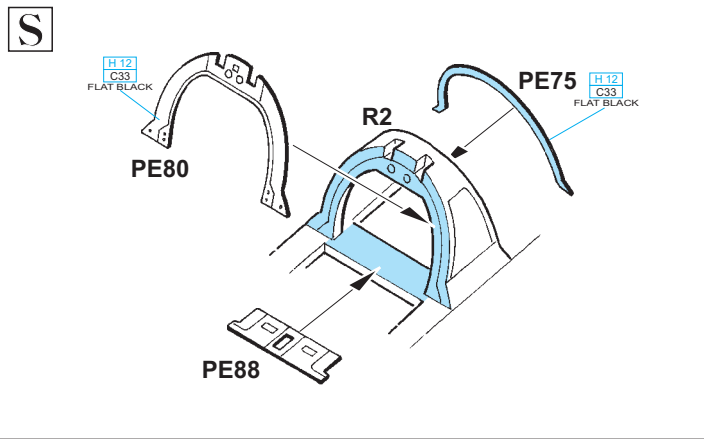
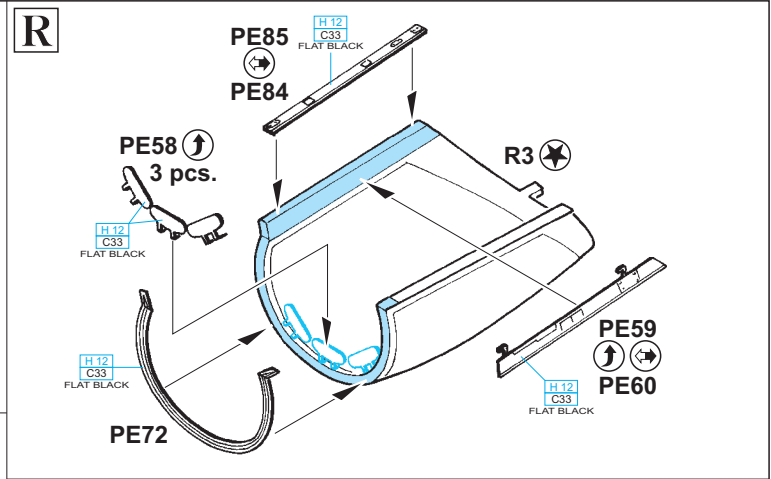
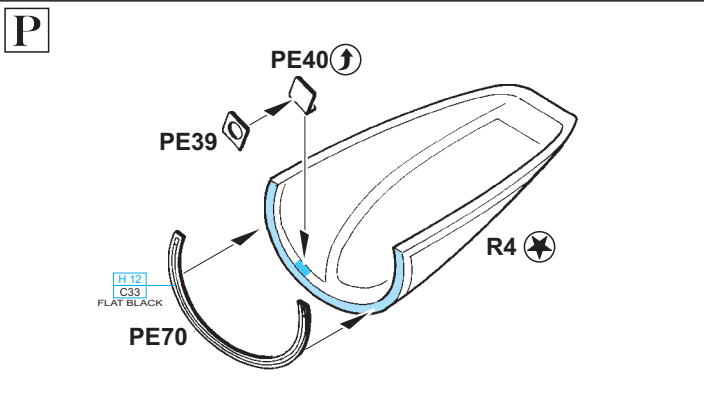

MOUNTING ARMS

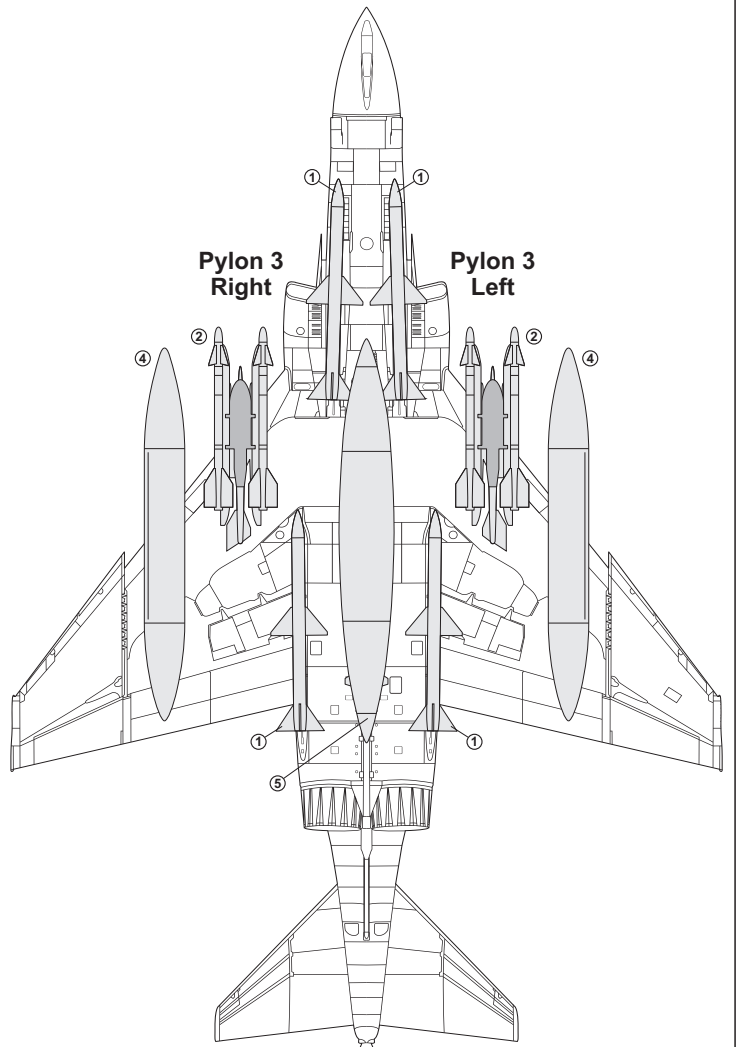
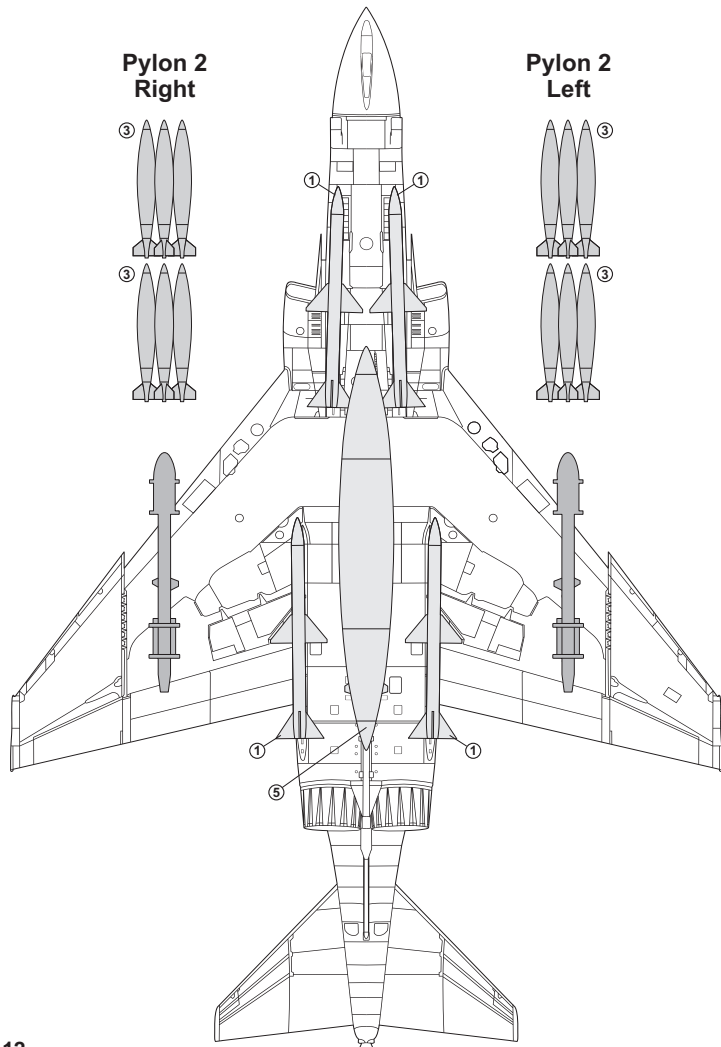
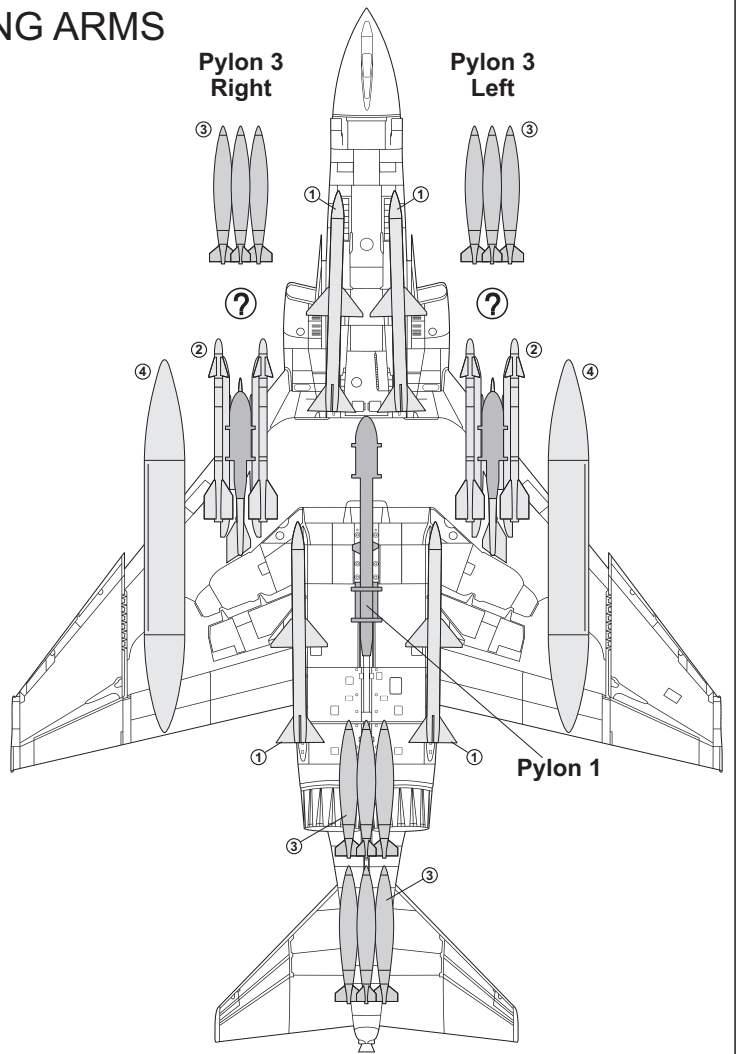
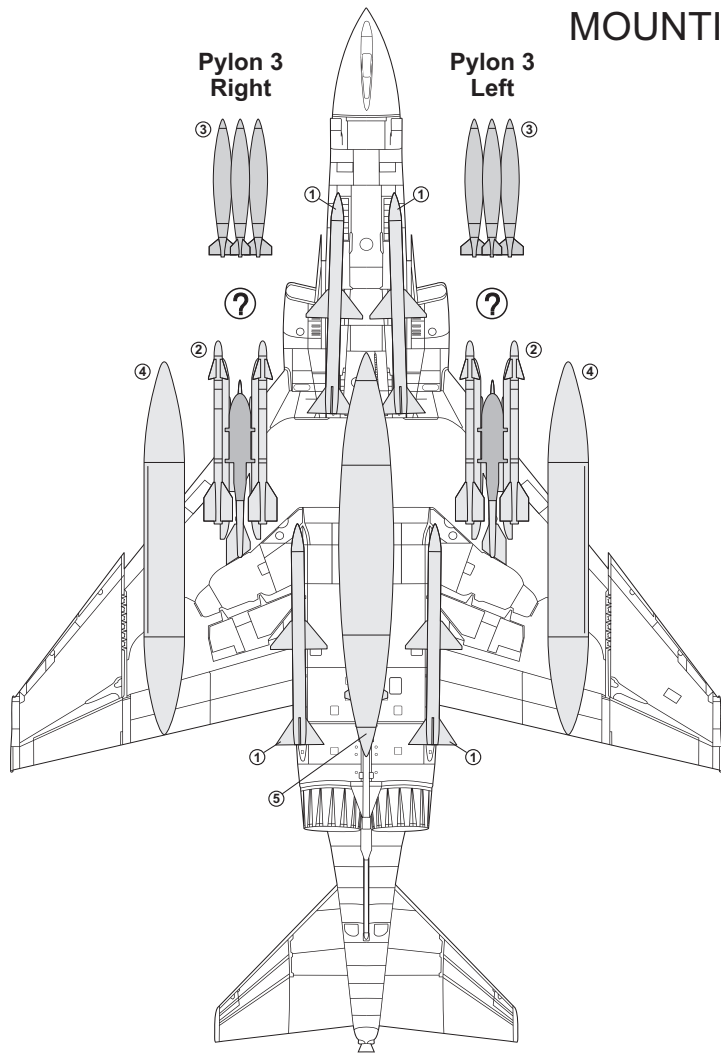

A F-4B 151492, VF-84 "Jolly Rogers", USS Independence, 1965

VF-84 se stala po sedm měsíců součástí Carrier Air Wing 7 a zúčastnila se v jeho řadách operace Rolling Thunder. Tato operace, probíhající od 2. března 1965 do 2. listopadu 1968, spočívala v bombardování cílů v komunistickém severním Vietnamu. Cílem bylo omezit podporu, kterou severní Vietnam poskytoval povstalcům v jižní části země. Během tohoto nasazení provedla VF-84 celkem 1507 operačních letů a působila z tzv. Yankee Station v Tonkinském zálivu. Za vynikající službu byla jednotka vyznamenána ceněným Battle „E“ (Battle Efficiency Award), jeho symbol je nakreslený na obou vstupech vzduchu k motorům. V této fázi války se mezi squadrony zařazenými do CVW-7 stal populárním emblém Tonkinského jachtklubu, také on byl namalován na trup letounu.

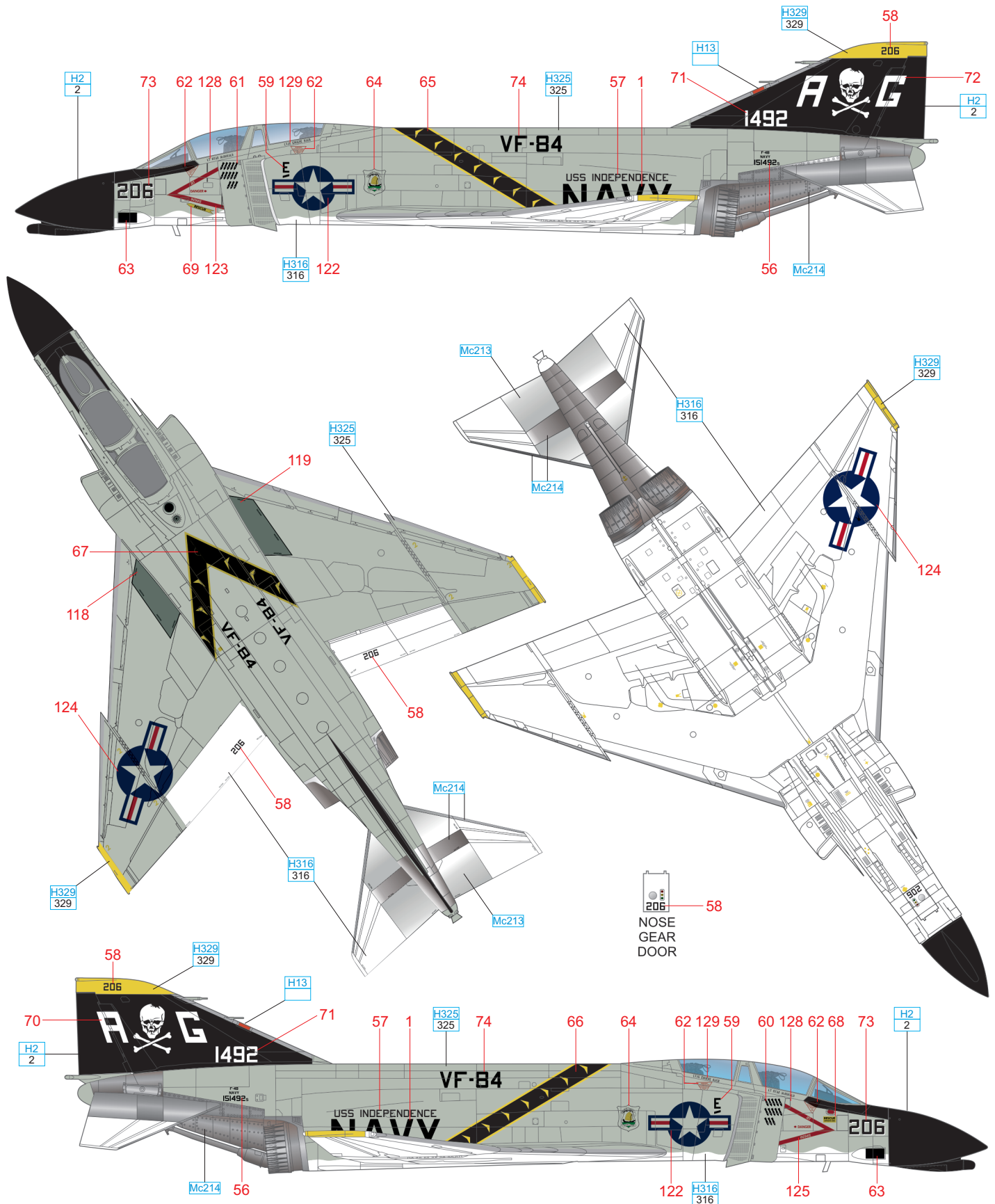

58
206
NOSE
GEAR
DOOR

- STEEL Mc213
- DARK IRON Mc214
- WHITE H316 316
- LIGHT GULL GRAY H325 325
- YELLOW H329 329
- RED H13
- BLACK H2 2



B F-4B 152238, VMFA-542 "Bengals", Da Nang Air Base, Jižní Vietnam, 1966

Letoun označený WH-1 sloužil po dvě operační túry, odsložené na základně Da Nang v letech 1965 a 1966, pod přezdívkou Tiger Lead třem velitelům této squadrony. Stroj u této jednotky odlétal více než 100 operačních letů, než byl přeložen k VMFA-323. V barvách této squadrony padl v roce 1967 za obětí protiletadlovému dělostřelectvu. Povrch letadla byl značně poznamenán provozem, viditelné byly úniky hydraulické kapaliny a četné kontroly koroze letounu.

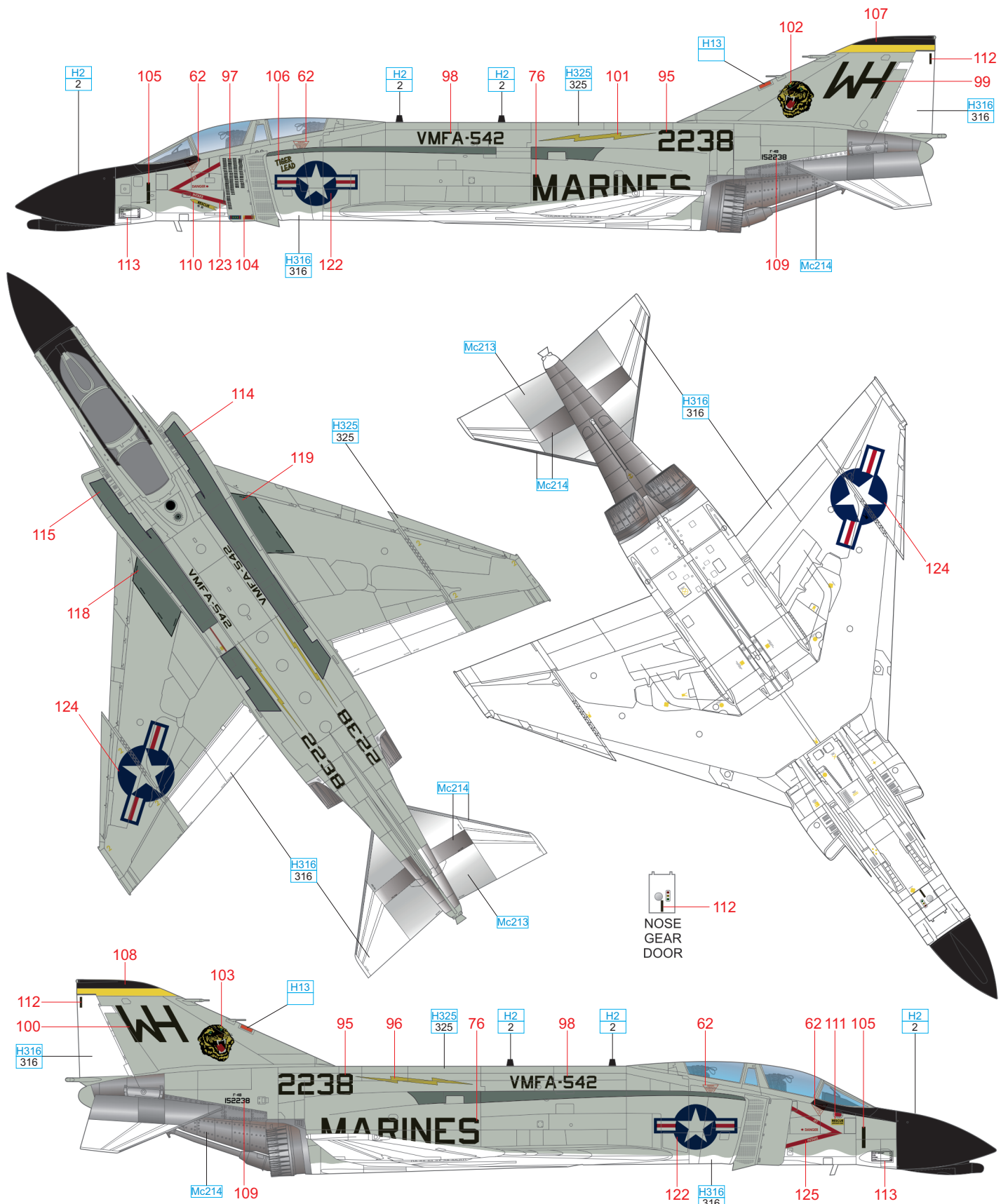

- STEEL Mc213
- DARK IRON Mc214
- WHITE H316 316
- LIGHT GULL GRAY H325 325
- RED H13
- BLACK H2 2



C F-4B 152258, VMFA-323 "Death Rattlers", Chu Lai Air Base, Jižní Vietnam, 1967

Death Rattlers byla jednou z řady stíhacích-bombardovacích jednotek námořní pěchoty, jež se zúčastnily války ve Vietnamu. Specializovala se na blízkou leteckou podporu (CAS – Close Air Support), tedy na přímou palebnou podporu pozemních jednotek marínů. Mezi roky 1966 a 1969 tento letecký útvar absolvoval celkem tři operační túry, během nichž ztratila jedenáct Phantomů. WS-11 byl skutečným tažným koněm, odlétal řadu misí. Po ukončení války prošel přestavbou na QF-4N. Na povrchu letounu byly zřetelné stopy způsobené intenzivním provozem, zejména stopy po kontrolách koroze draku.

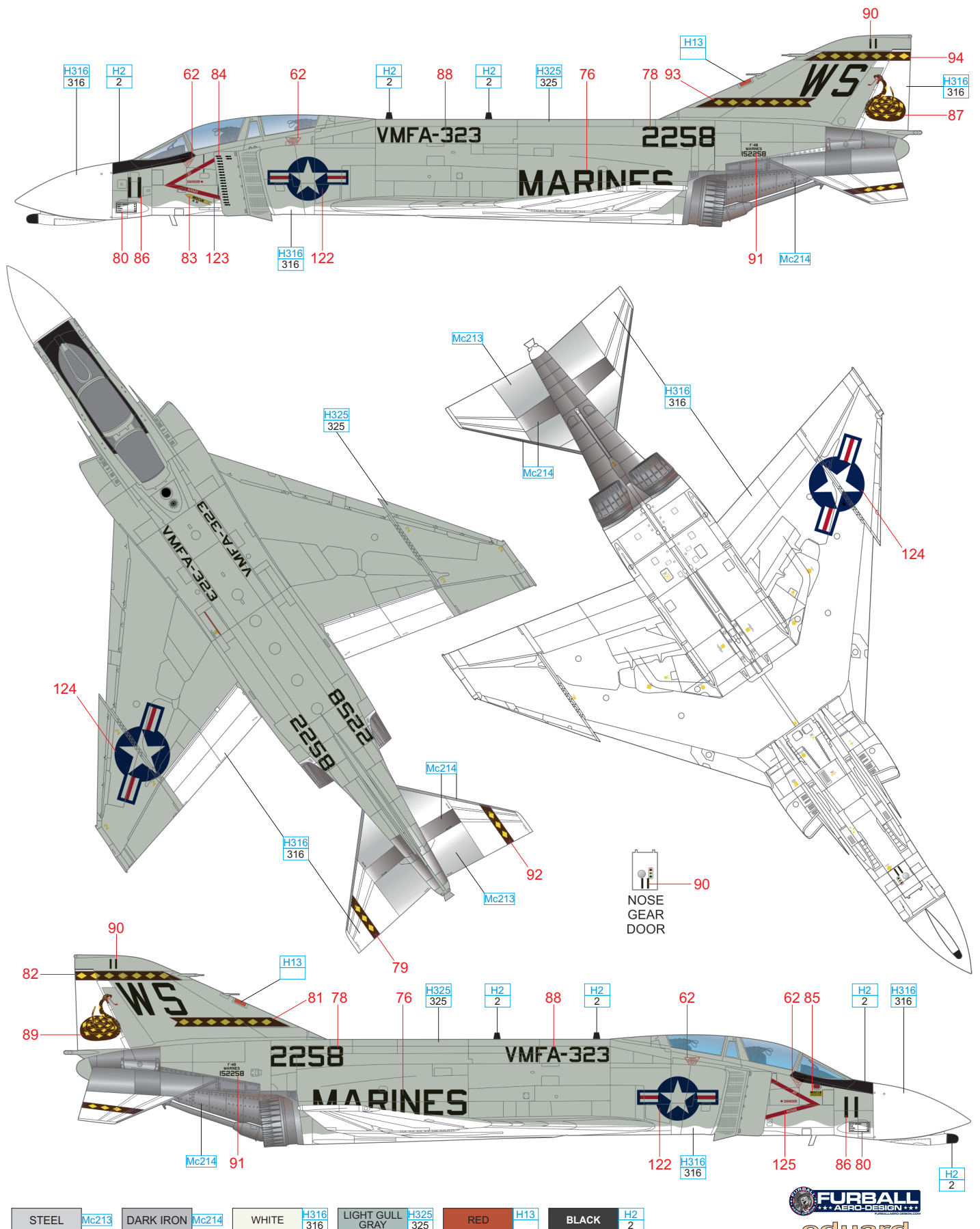

D F-4B 153020, VF-161 "Chargers", USS Midway, květen 1972

Osádka tohoto letounu ve složení pilot LCDR Donald McKeown a operátor LT John Ensich dosáhla v jeho kokpitu dvou sestřelů. Oba nepřátelské letouny, jednalo se o MiGy-17, poslali k zemi 23. května 1972. LT Ensich usedl do kokpitu tohoto letounu také o tři měsíce později, dne 25. srpna 1972, tentokrát společně s pilotem LCDR Michaelem Doylem. NF100 však byl během tohoto operačního letu nad vietnamským Nam Dinh zasažen protiletadlovou raketou typu SAM. LCDR Doyle zahynul, LT Ensich měl více štěstí a přežil. Padl však do zajetí, v němž strávil zbytek války.

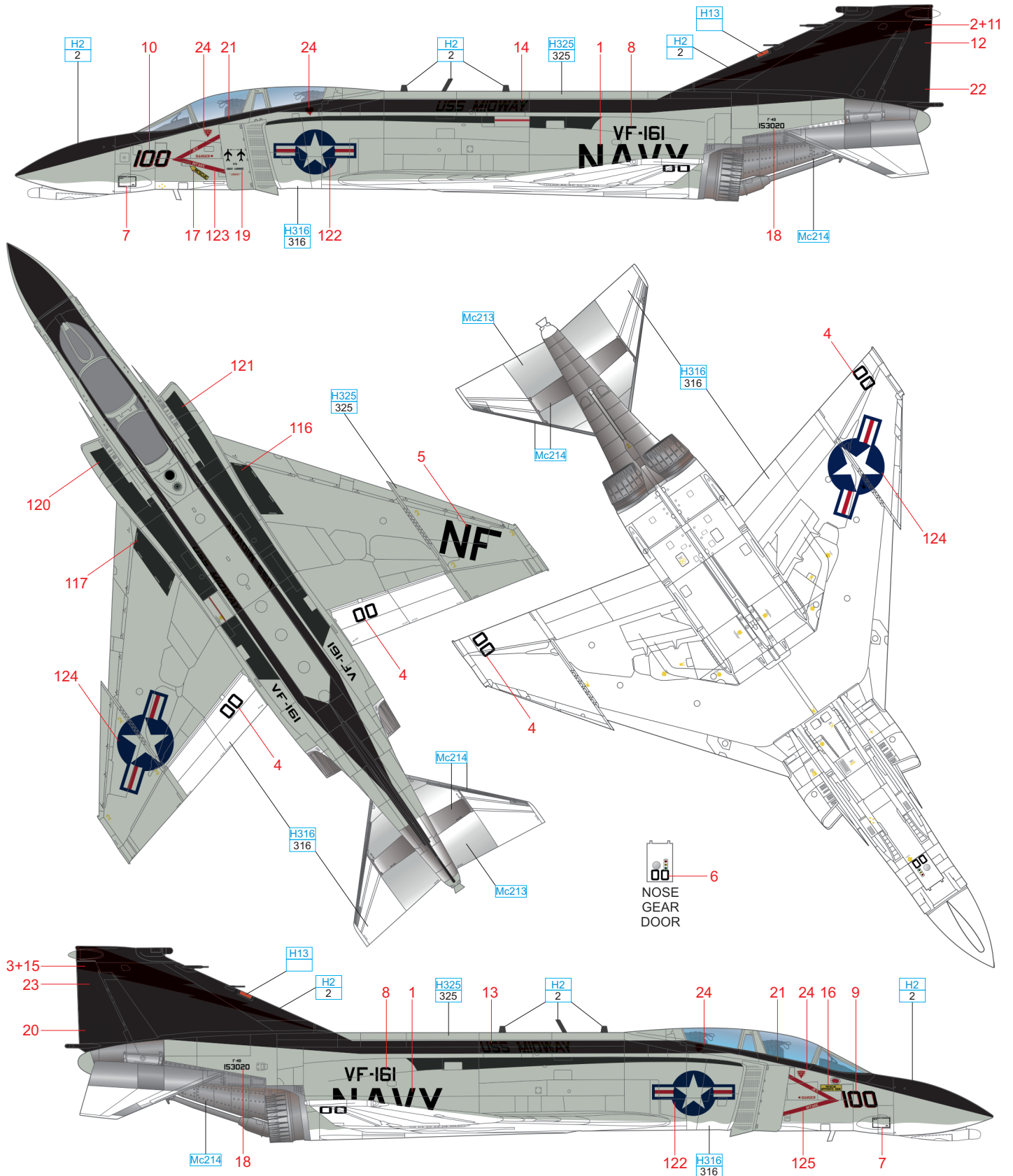

STEEL	Mc213	DARK IRON	Mc214	WHITE	H316 316	LIGHT GULL GRAY	H325 325	RED	H13	BLACK	H2 2
-------	-------	-----------	-------	-------	-------------	--------------------	-------------	-----	-----	-------	---------



E F-4B 153019, VF-111 "Sundowners", USS Coral Sea, březen 1972

Letoun má celkem bohatou minulost. Přimo z výrobní linky putoval v roce 1966 k VF-213. U této jednotky s ním osádka LT David McCrea / ENS David Nichols sestřelila v noci dne 20. prosince 1966 letoun identifikovaný jako An-2. Tento sestřel byl v podobě žluté hvězdičky zaznamenán na oba oddělovače mezní vrstvy. Další úspěch letoun zaznamenal u VF-111. Dne 6. března 1972 s ním sestřelila osádka LT Garry Weigand a LTJG William Freckleton jeden MiG-17. Na tuto událost upomíná černá silueta MiGu, opět nakreslená na obou stranách letounu.

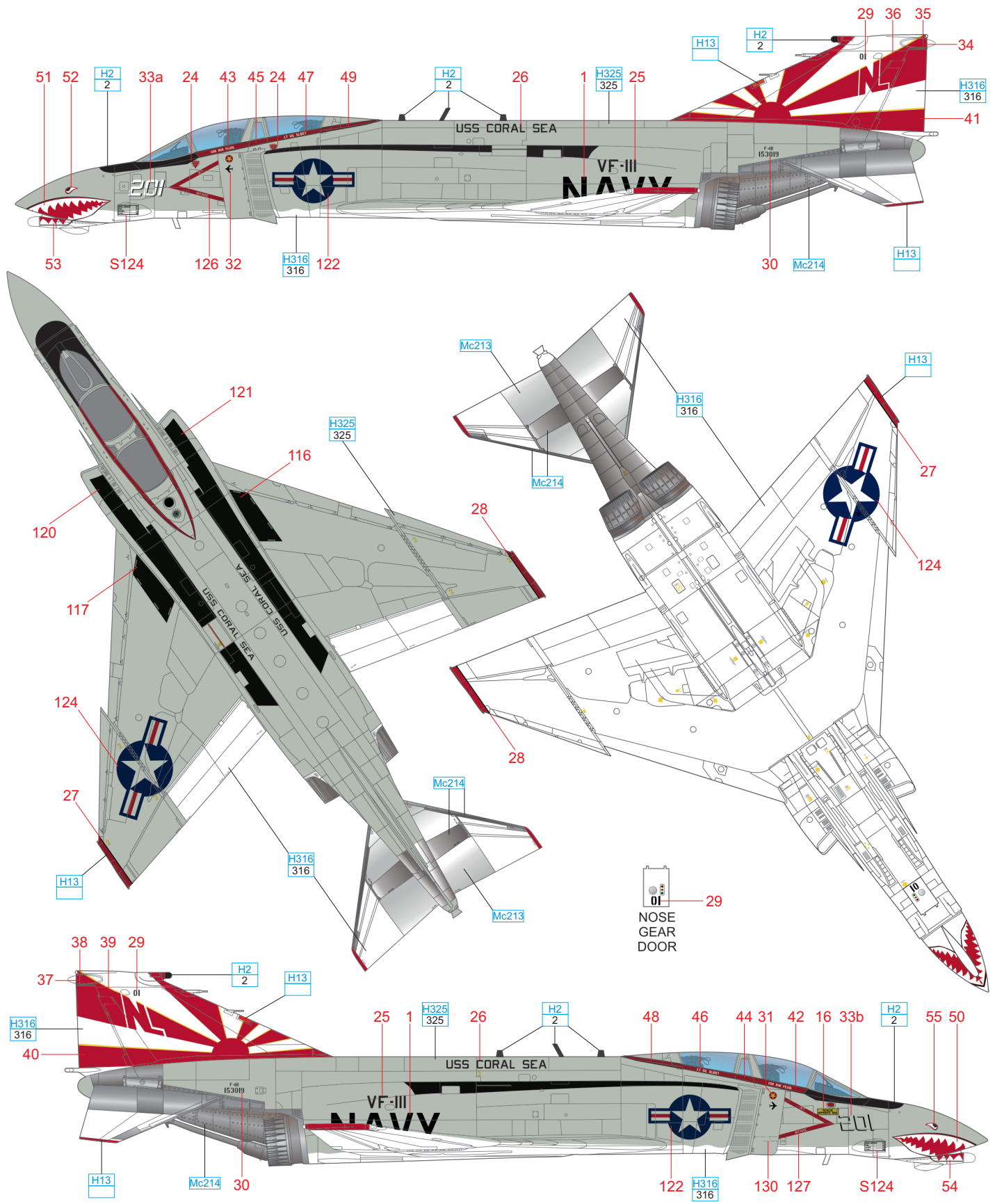

STEEL	Mc213	DARK IRON	Mc214	WHITE	H316 316	LIGHT GULL GRAY	H325 325	FLAT RED	H13	BLACK	H2 2
-------	-------	-----------	-------	-------	----------	-----------------	----------	----------	-----	-------	------



ACCESS DOOR MARKINGS PORT & STARBOARD VIEWS

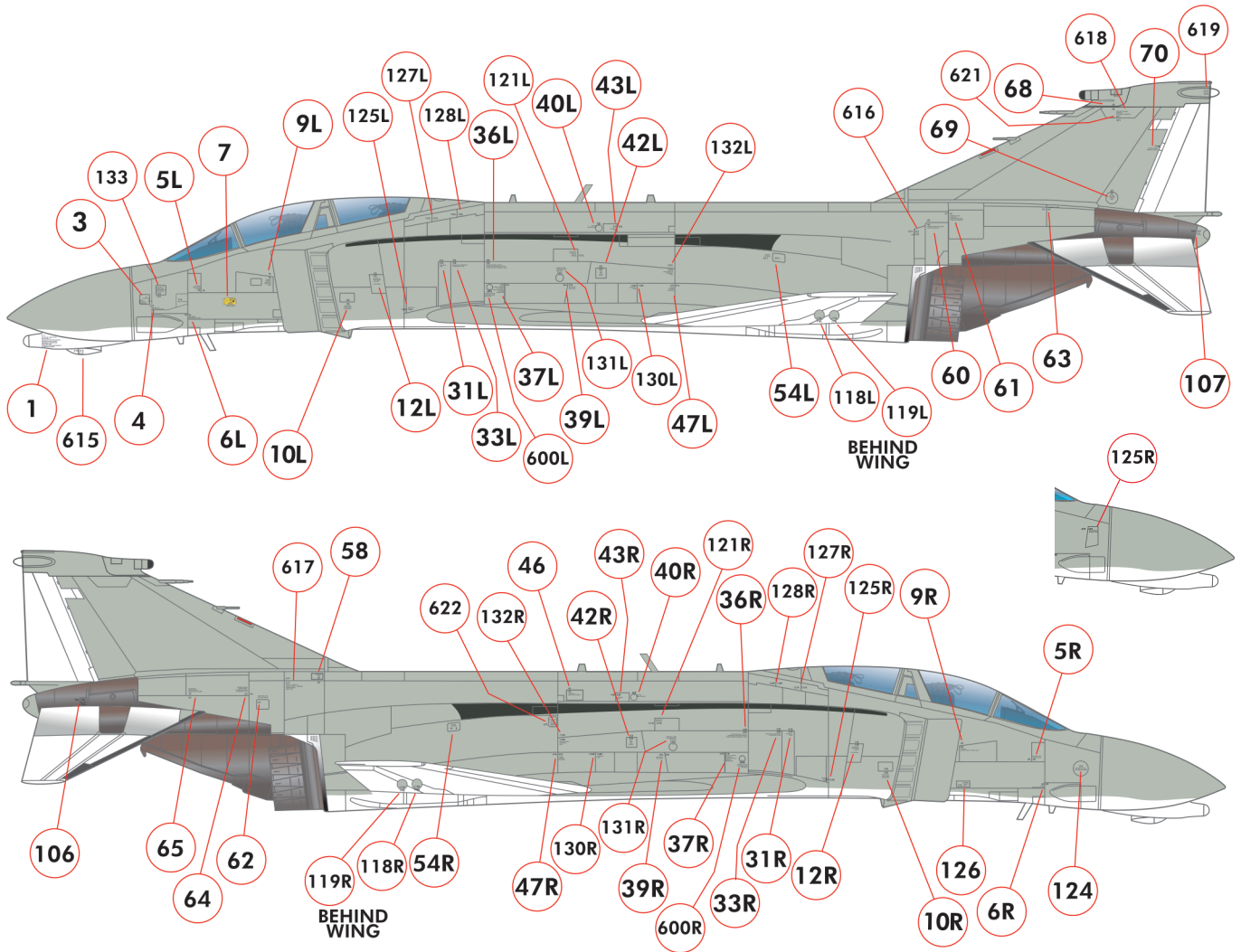

INSTRUCTIONAL MARKINGS PORT & STARBOARD VIEWS

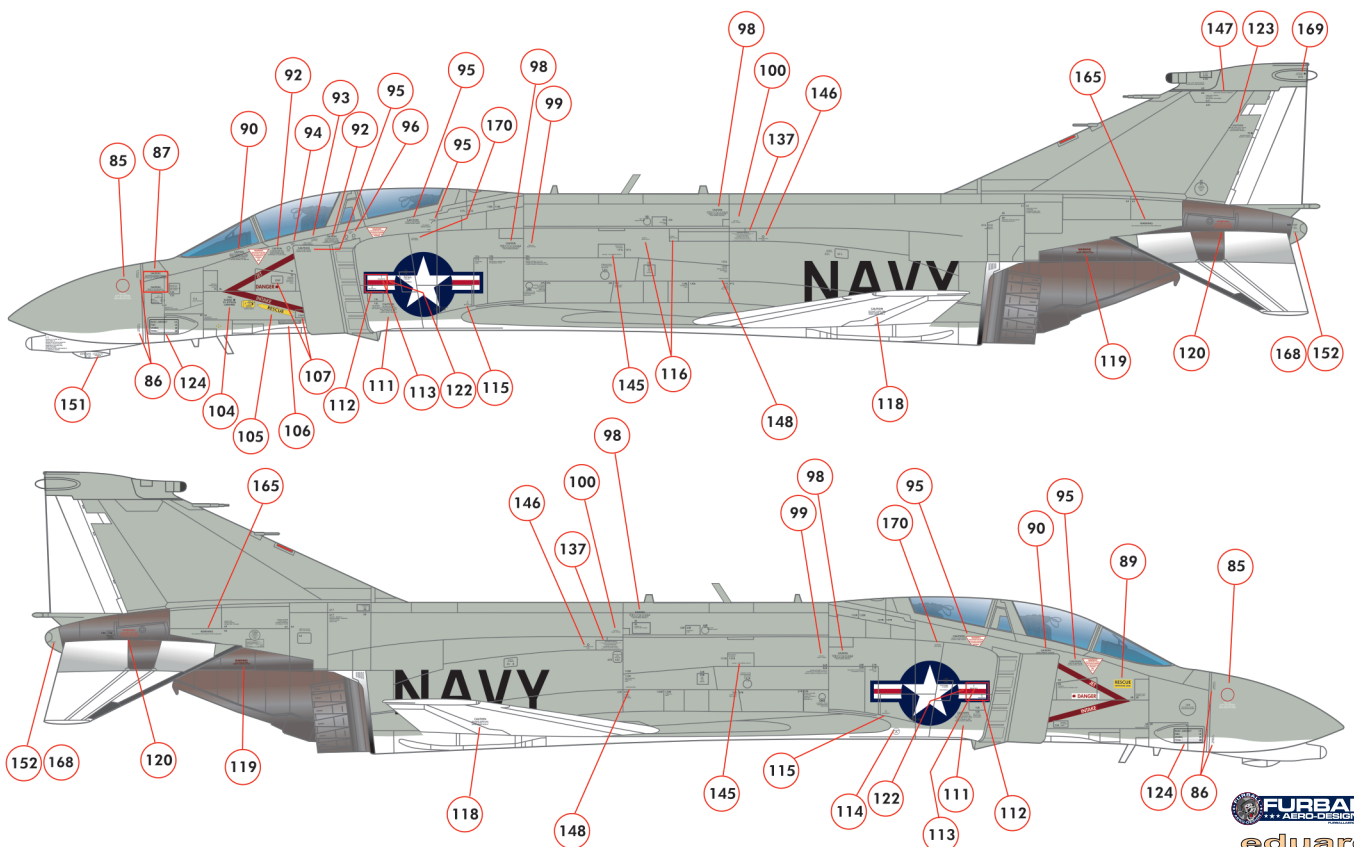

ACCESS DOOR MARKINGS TOP VIEW

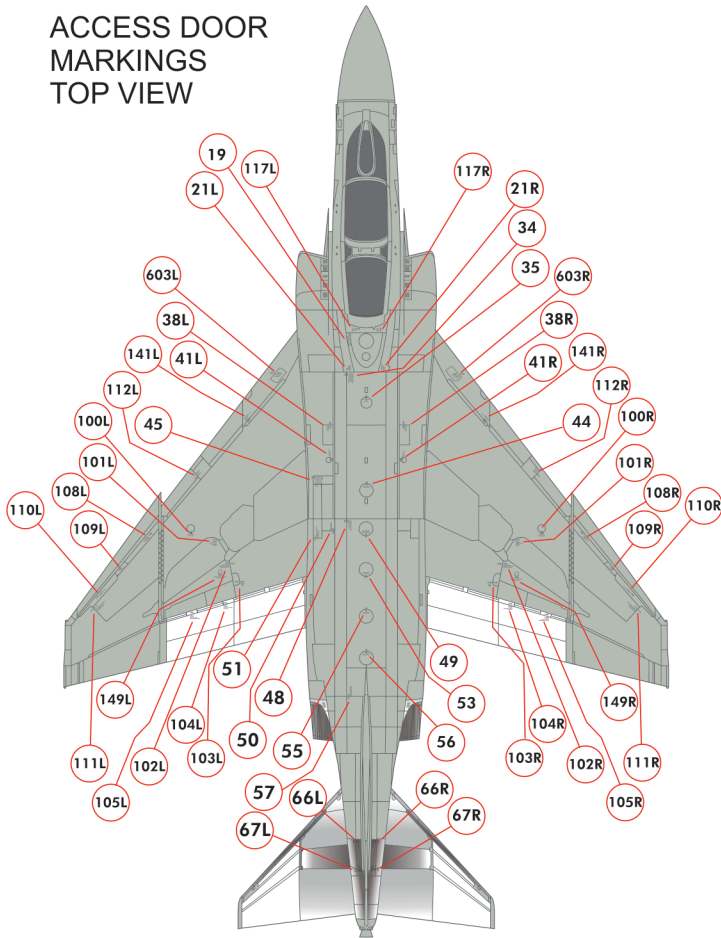

INSTRUCTIONAL MARKINGS TOP VIEW

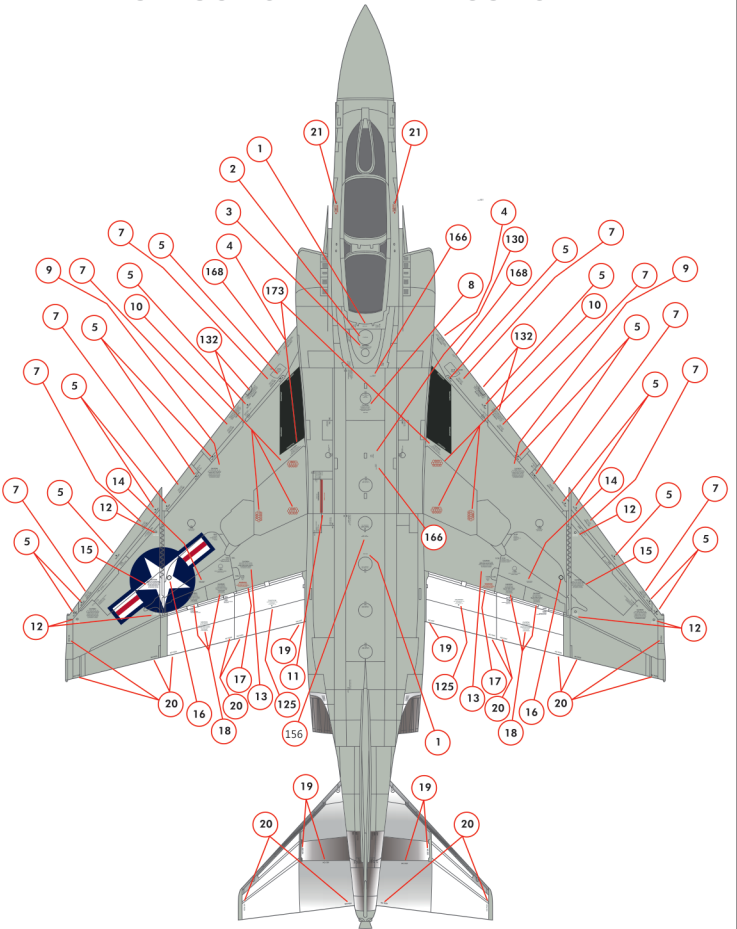

ACCESS DOOR MARKINGS BOTTOM VIEW

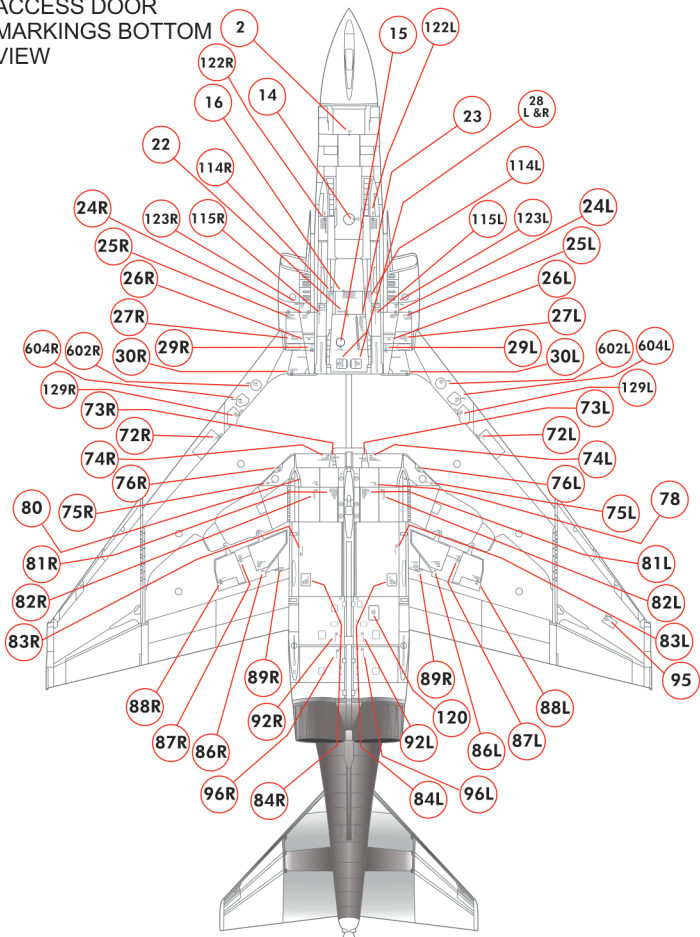

INSTRUCTIONAL MARKINGS BOTTOM VIEW

