



RIDERS IN THE SKY 1944

INSTRUCTIONS

eduard

2121 - NAV1

ATTENTION



UPOZORNĚNÍ



ACHTUNG



ATTENTION



注意



Carefully read instruction sheet before assembling. When you use glue or paint, do not use near open flame and use in well ventilated room. Keep out of reach of small children. Children must not be allowed to suck any part, or pull vinyl bag over the head.



Před započítím stavby si pečlivě prostudujte stavební návod. Při používání barev a lepidla pracujte v dobře větrané místnosti. Lepidla ani barvy nepoužívejte v blízkosti otevřeného ohně. Model není určen malým dětem, mohlo by dojít k požití drobných dílů.

INSTRUCTION SIGNS * INSTR. SYMBOLS * INSTRUKTION SINNBILDEN * SYMBOLES * 記号の説明

OPTIONAL
VOLBABEND
OHNOUOPEN HOLE
VYVRTAT OTVORSYMMETRICAL ASSEMBLY
SYMETRICKÁ MONTÁŽREMOVE
ODŘÍZNOUTREVERSE SIDE
OTOČITAPPLY EDUARD MASK
AND PAINT
POUŽÍT EDUARD MASK
NABARVIT

PARTS



DÍLY



TEILE



PIÈCES



部品

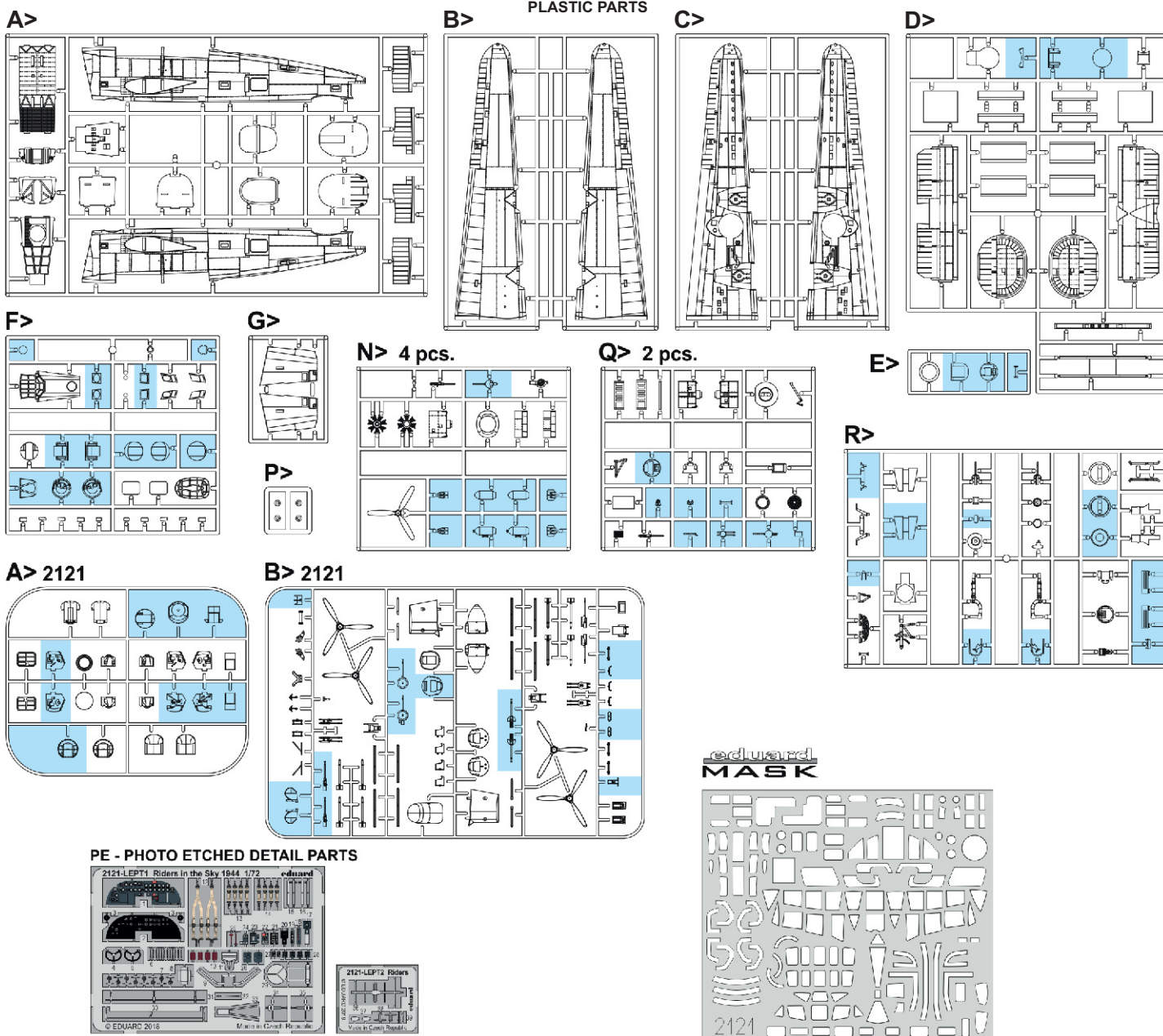

-Parts not for use. -Teile werden nicht verwendet. -Pièces à ne pas utiliser. -Tyto díly nepoužívejte při stavbě. - 使用しない部品

COLOURS



BARVY



FARBEN



PEINTURE



色

GSI Creos (GUNZE)		
AQUEOUS	Mr.COLOR	
H8	C8	SILVER
H11	C62	WHITE
H12	C33	FLAT BLACK
H32	C40	FIELD GRAY
H52	C12	OLIVE DRAB
H53	C13	NEUTRAL GRAY
H77	C137	TIRE BLACK
H78	C38	OLIVE DRAB
H90	C47	CLEAR RED

AQUEOUS	Mr.COLOR	
H92	C49	CLEAR ORANGE
H93	C50	CLEAR BLUE
H94	C138	CLEAR GREEN
H333	C333	EXTRA DARK SEAGRAY
	C351	ZINC-CHROMATE
	C352	CHROMATE YELLOW
Mr.METAL COLOR		
	MC213	STAINLESS
	MC214	DARK IRON

MARKINGS **A, C-F ONLY**

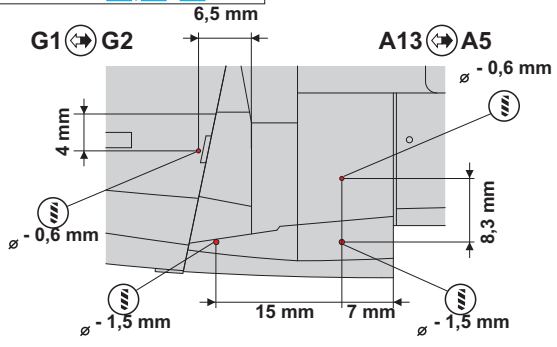

INTERIOR COLOR - BARVA INTERIÉRU

INTERIOR
90% + 10%
ZINC-CHROMATE TYPE I FLAT BLACK

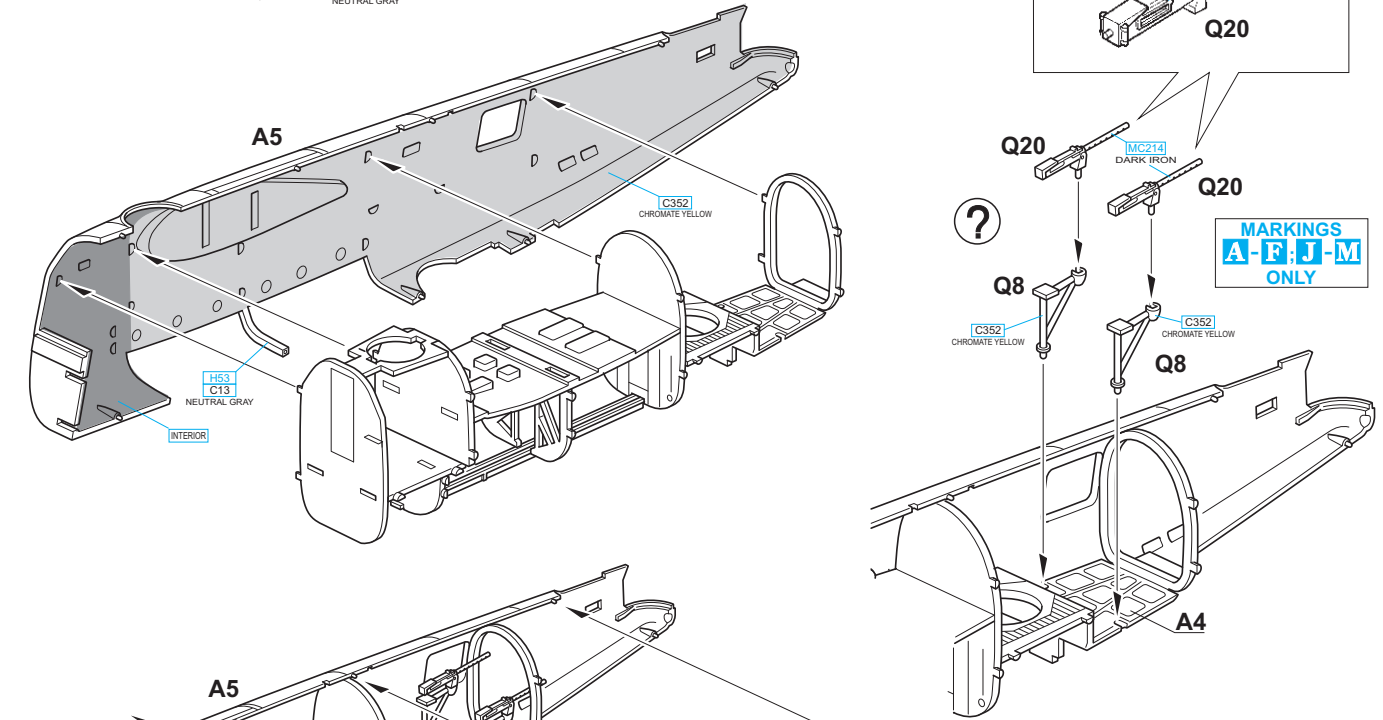
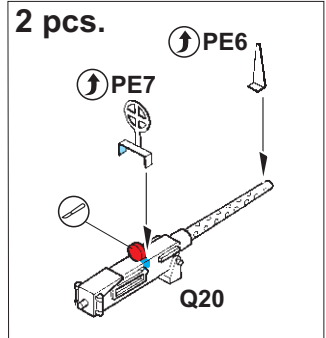
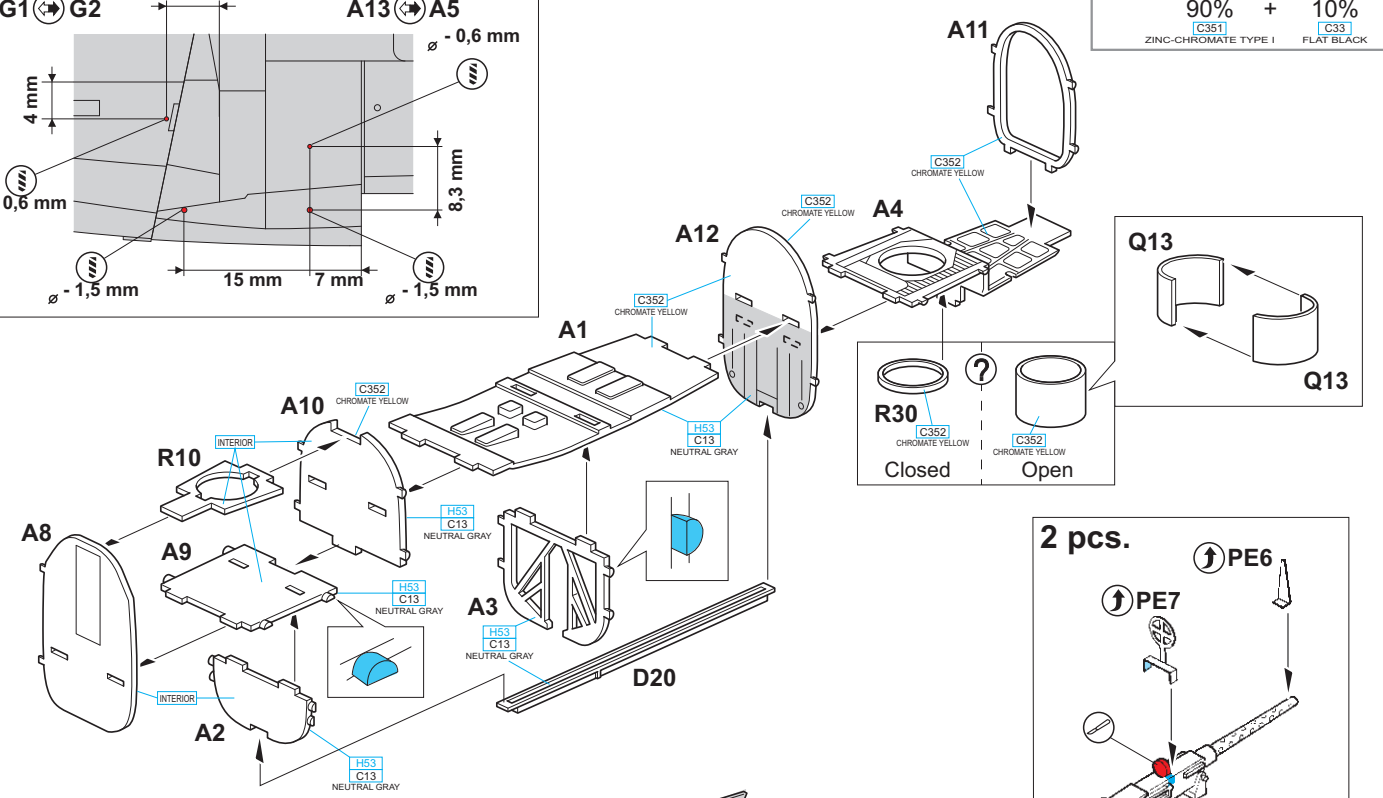

MARKINGS **A-F, J-M ONLY**

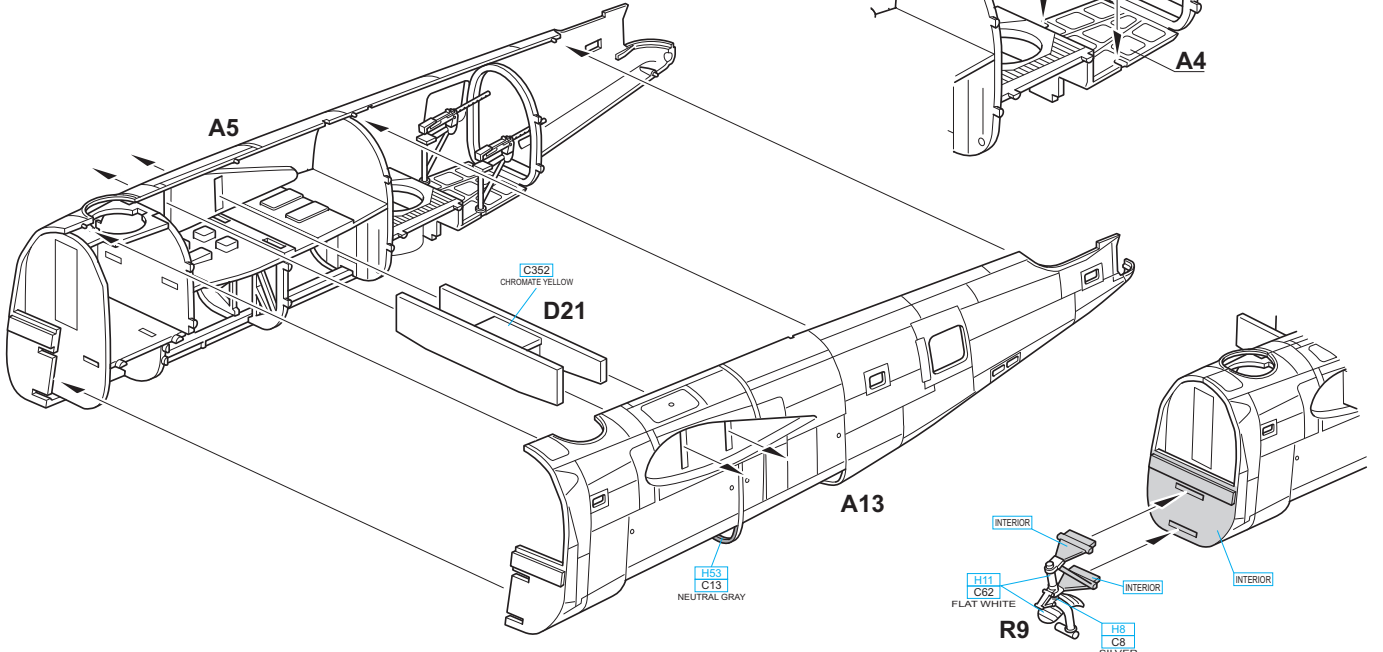

A

PE20

PE17

OPTIONAL:
decal 34

R2

PE2

PE1

PE8

PE21

PE26

plastic
ø - 0,5 mm
l - 0,8 mm

PE4

PE5

H12
C33
FLAT BLACK

B

PE18

PE19

PE22

R25

PE3

PE3

plastic
ø - 0,5 mm
l - 0,8 mm

PE23

PE25

PE27

PE28 3 pcs.

PE24

C

3 pcs.

PE13

PE10

2 pcs.

PE12

PE15

Q12

Q12

PE14

PE16

H78
C38
OLIVE DRAB

A7

R12

INTERIOR

G2

fill

F10, F11 - MARKINGS **A-F; J; L; M**
F12, F13 - MARKINGS **G-I; K**

D

PE7

N2

MARKINGS **A-F; J; L; M**
ø - 0,3 mm

MARKINGS **A-D; G; H; M**
ø - 0,8 mm

F23

ø - 0,8 mm

MARKINGS **E; F; J-L**

ballast

MC214
DARK IRON

fill

MARKINGS **A-F; L; M**

G1

MARKINGS **G-K**

G1

fill

MC214
DARK IRON

PE6

N2

PE14

PE29

PE9

PE11

G1

INTERIOR

Don't forget
to add the nose
weight balance!

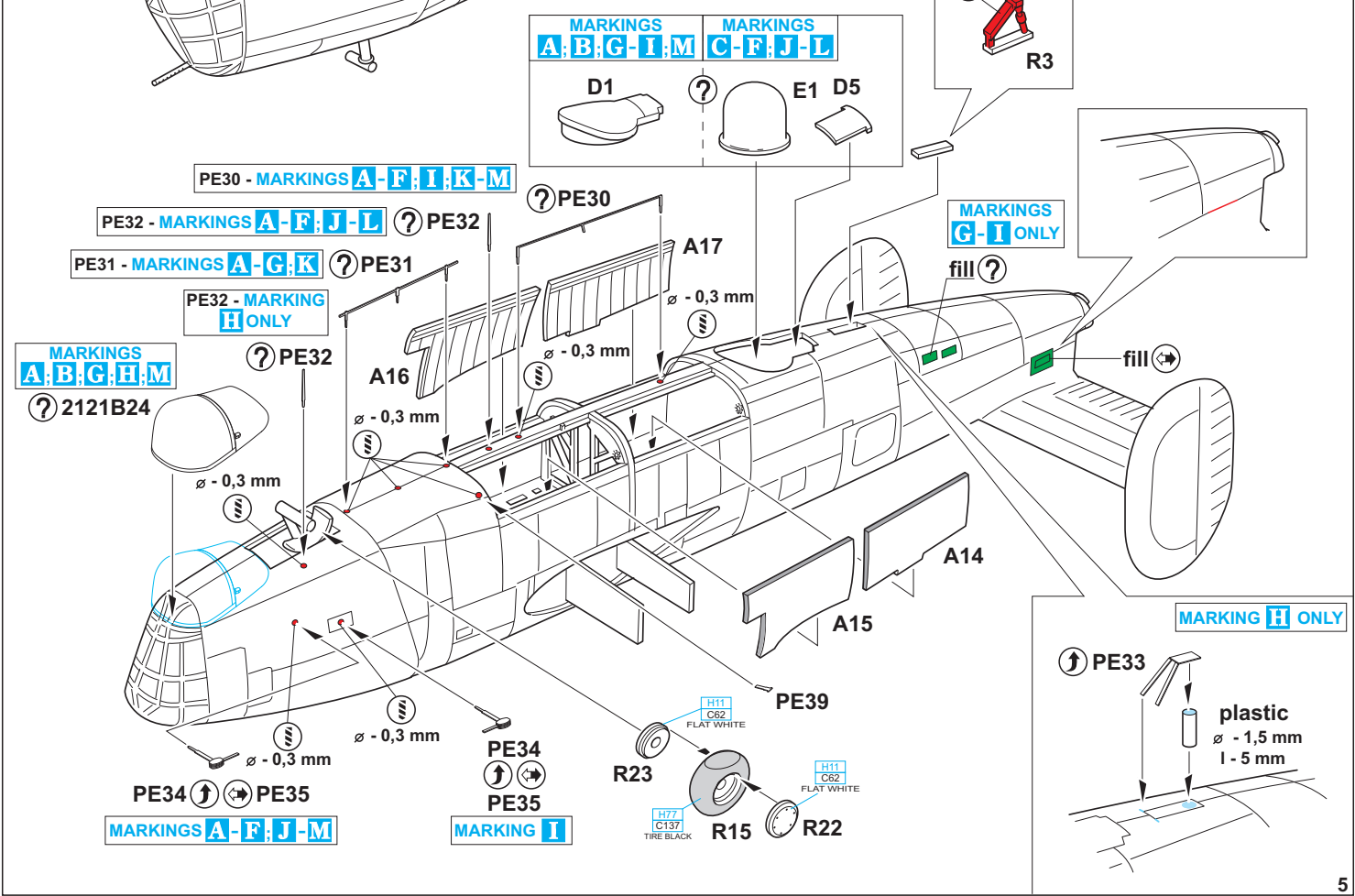
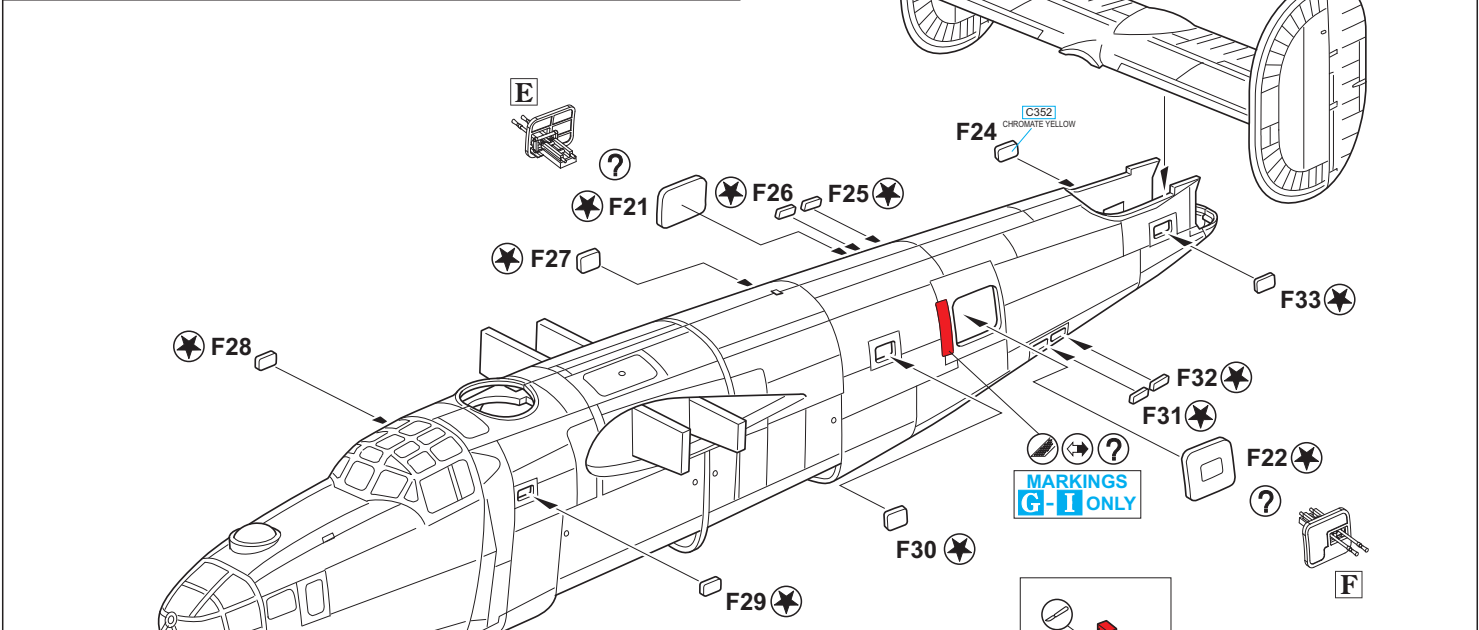
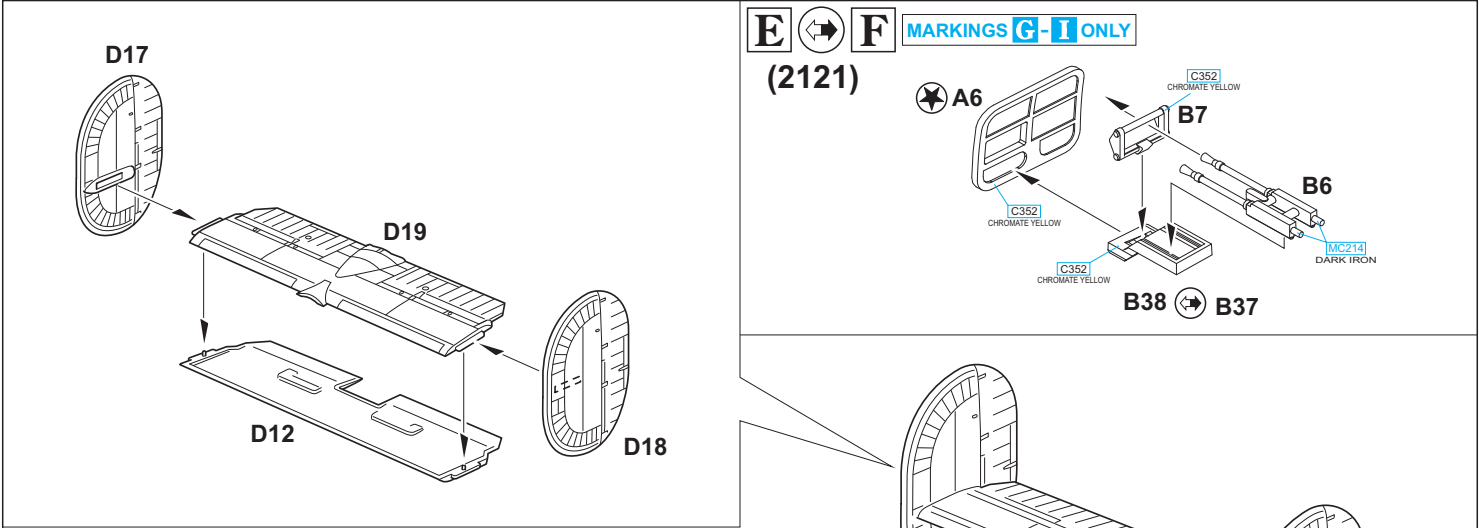

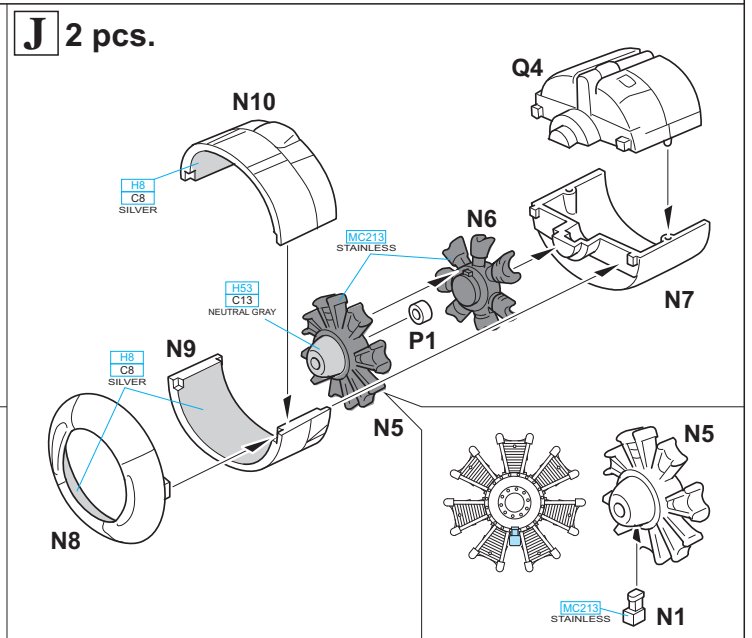
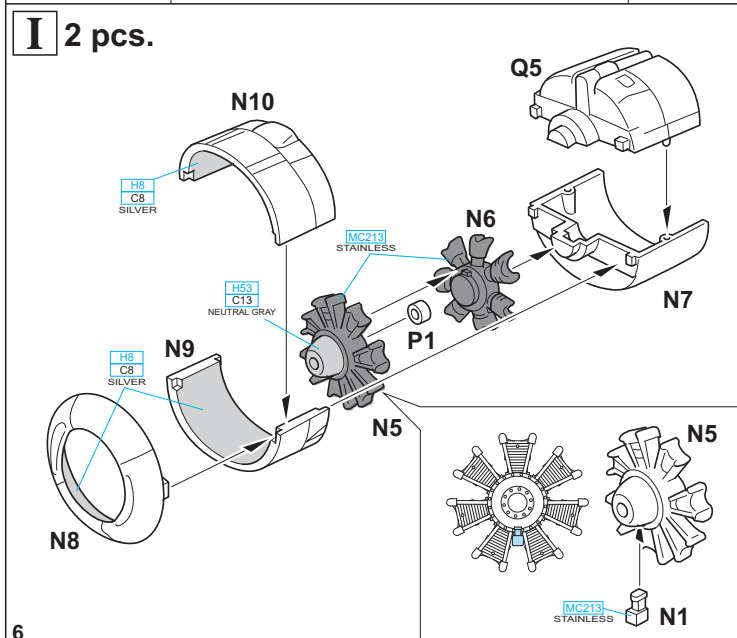
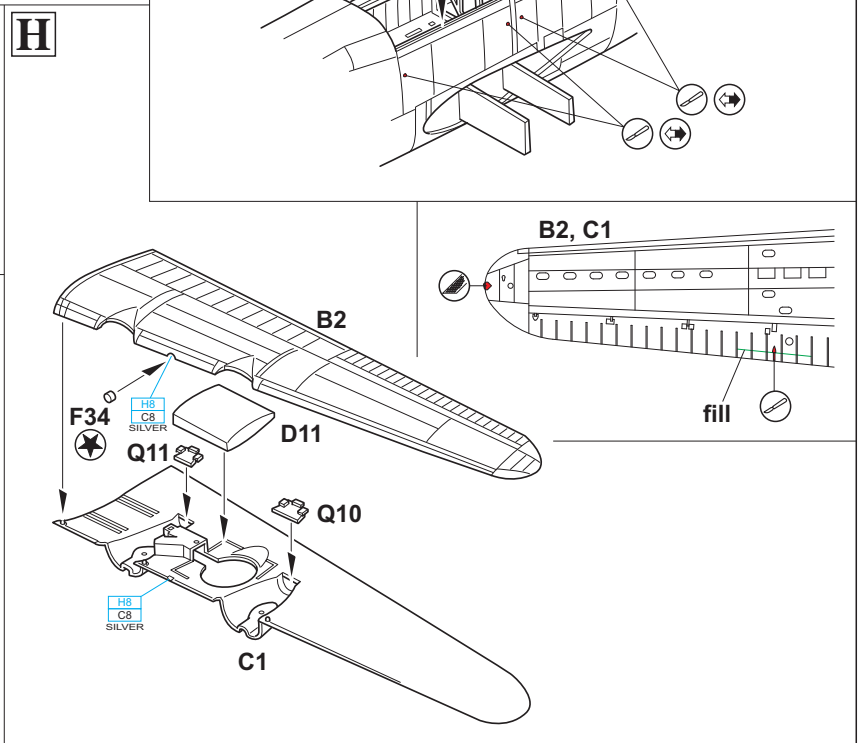
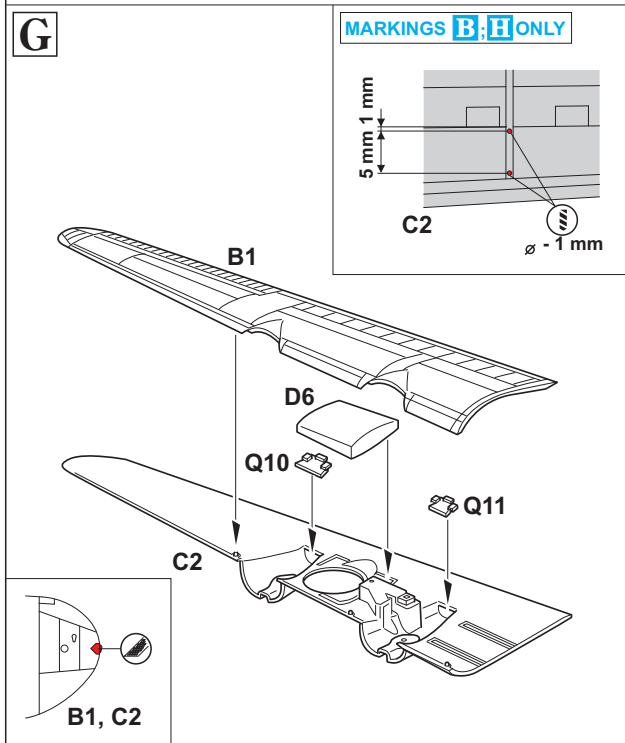
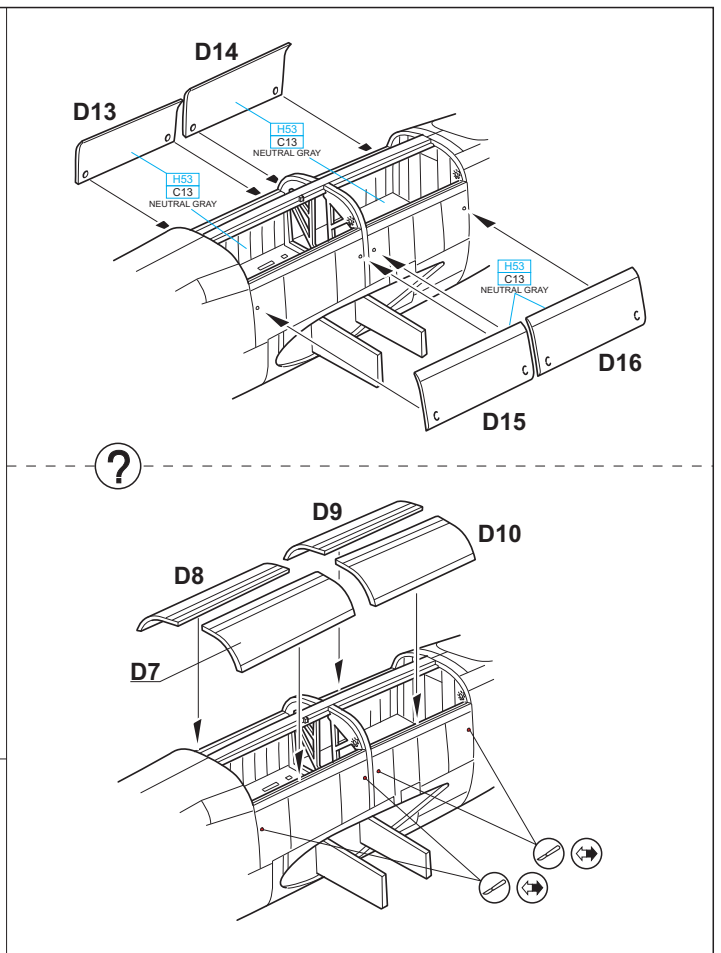
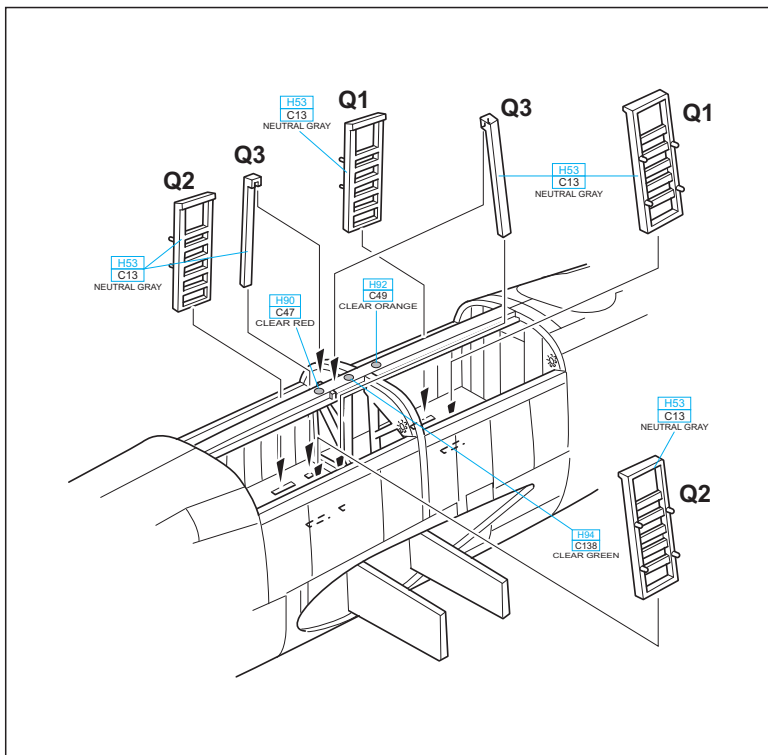

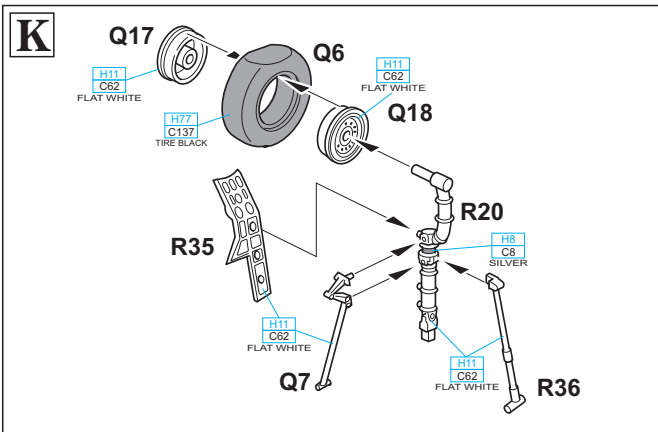

(2121) MARKINGS B, F ONLY

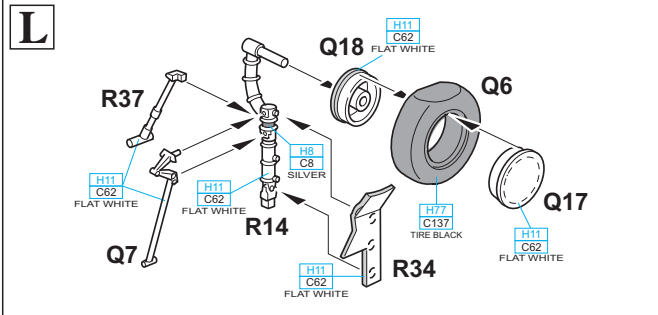
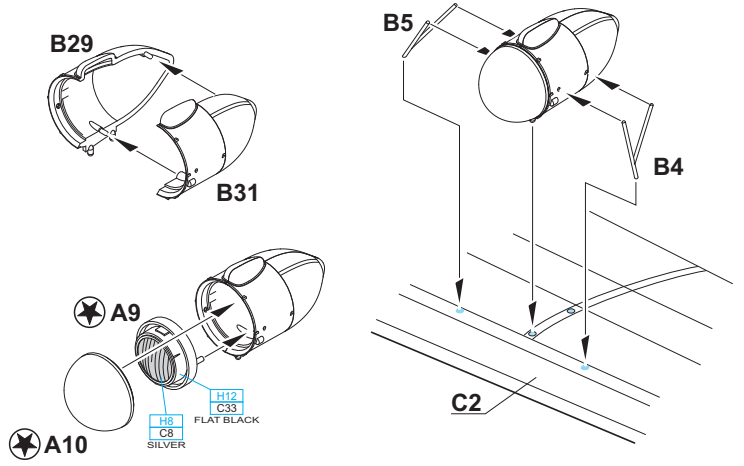

N

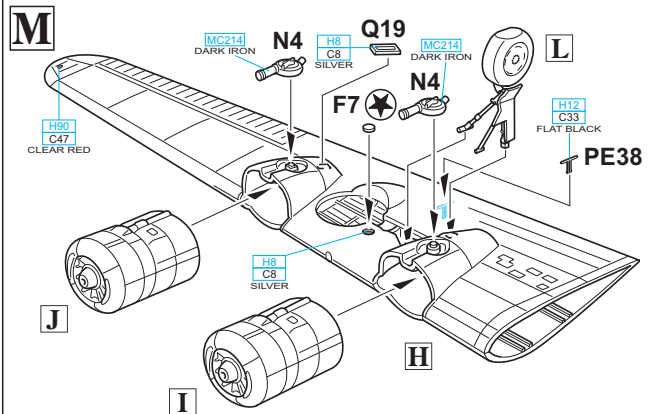
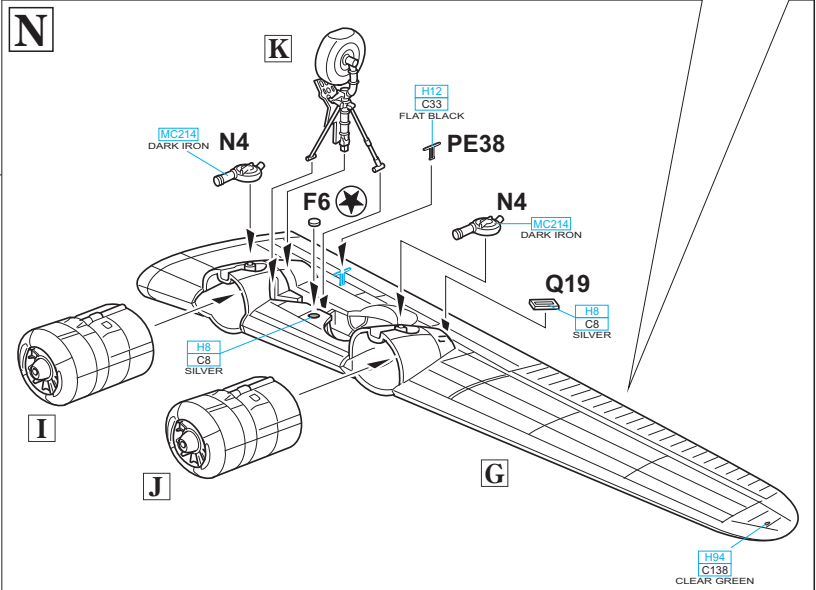

O (2121)

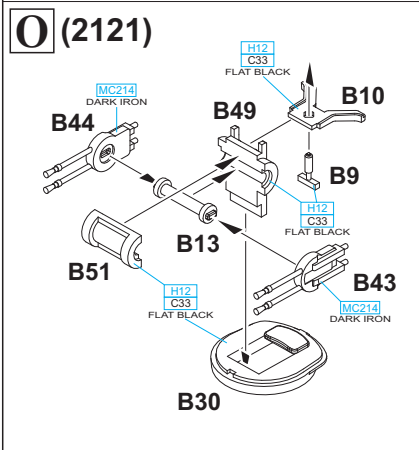

P (2121) MARKINGS A-F, J, K

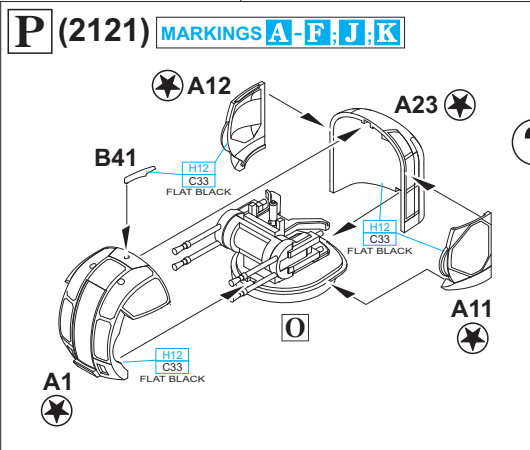

Q (2121) MARKINGS G, H, I

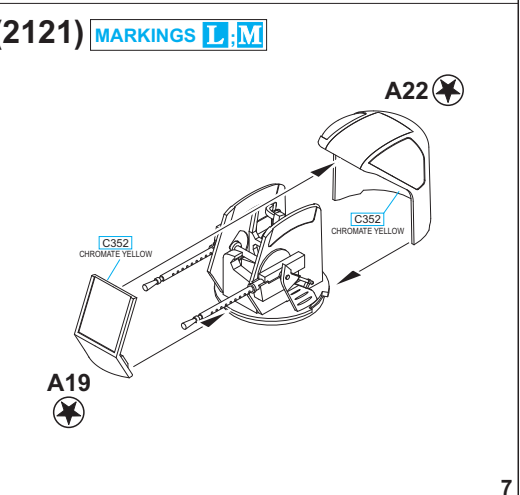
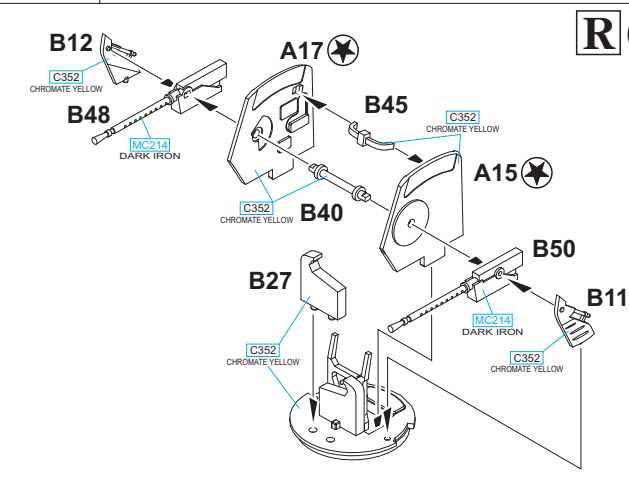
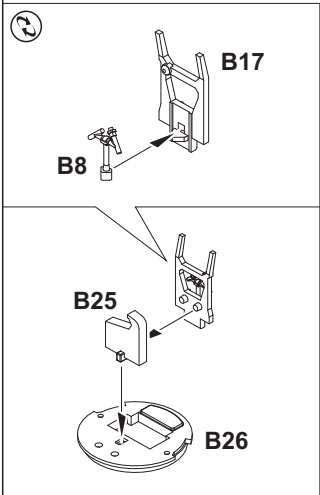
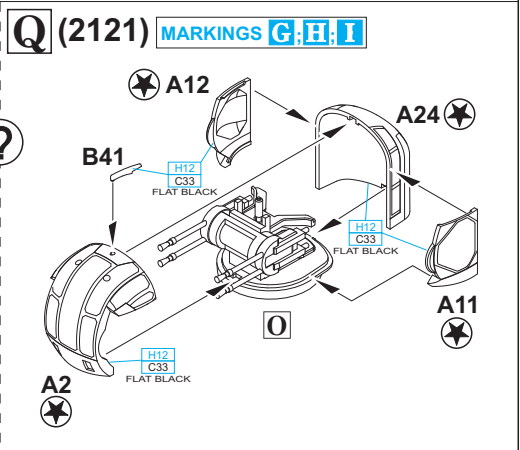

S (2121)

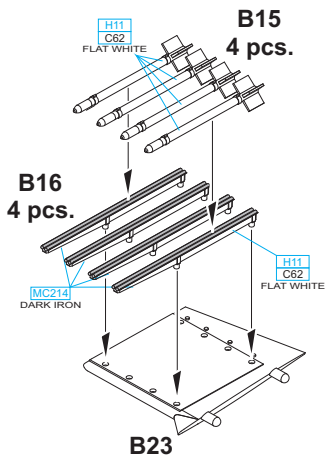

T (2121)

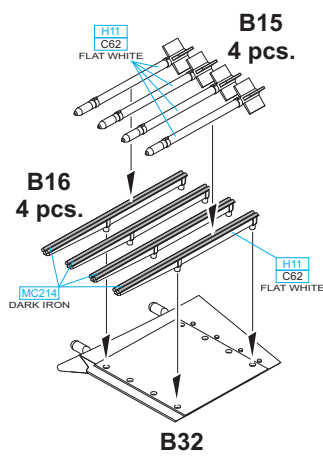

MARKINGS **A, C-F** ONLY

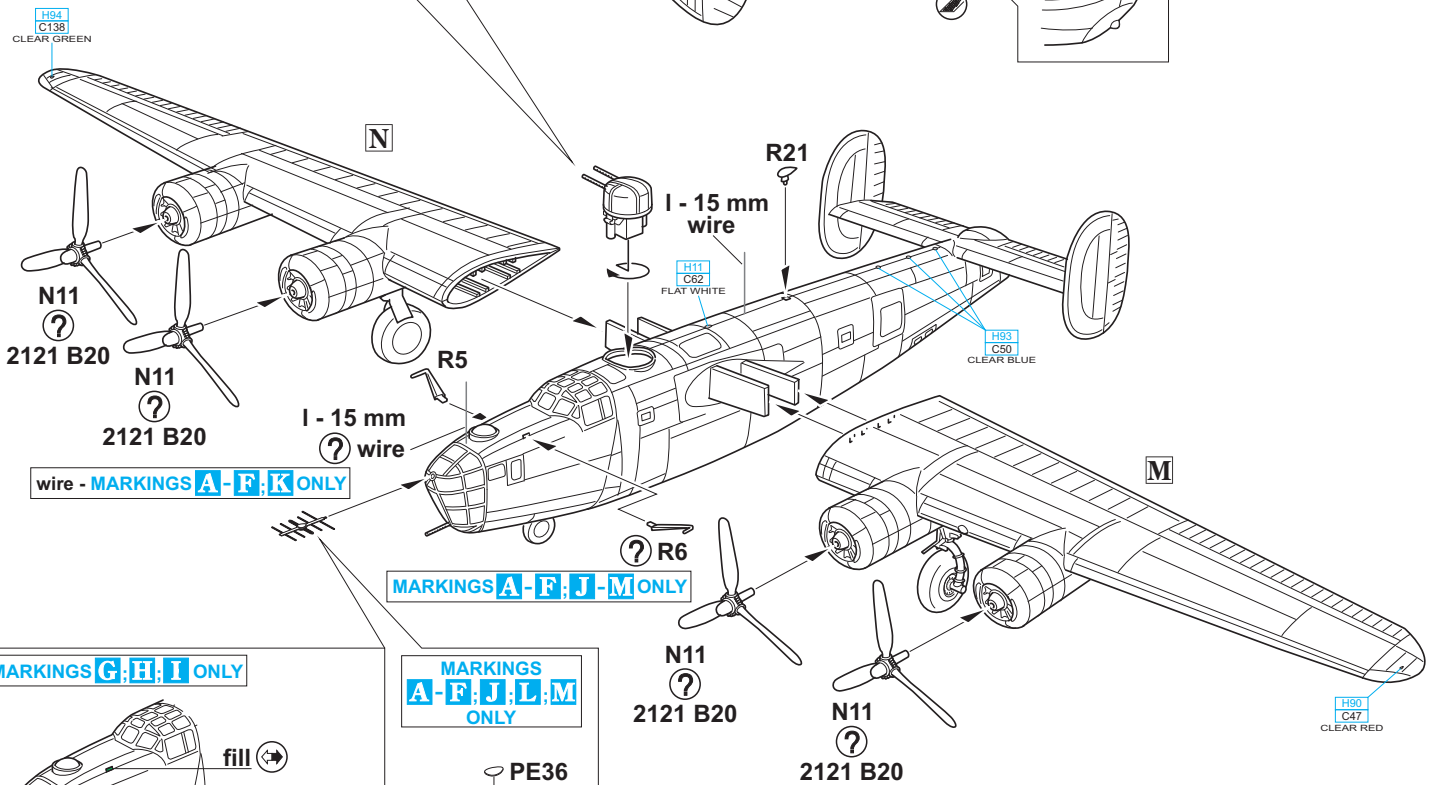
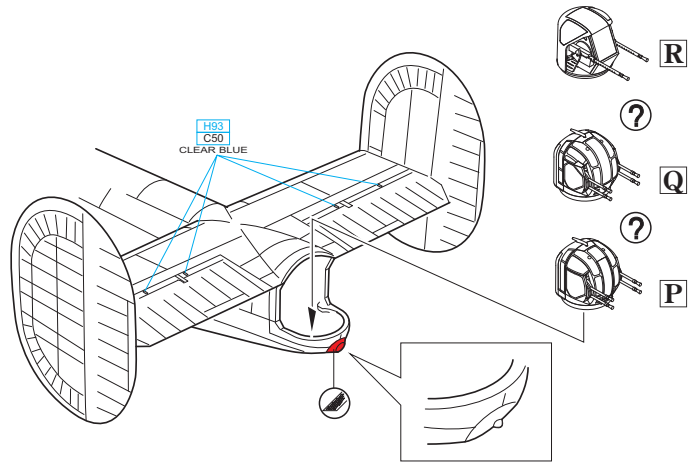
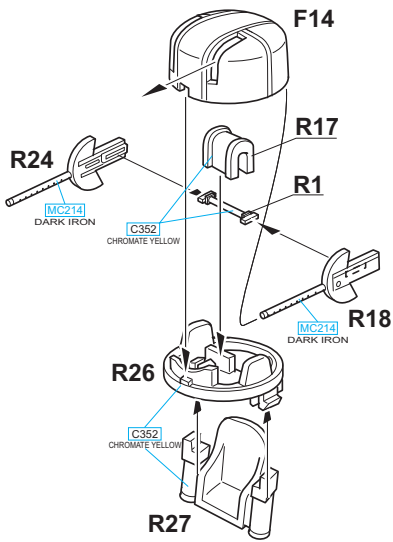
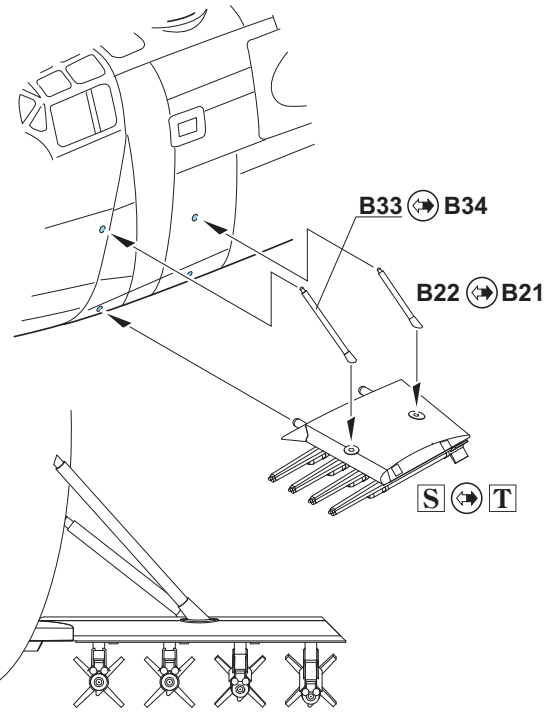

wire - MARKINGS **A-F;K** ONLY

MARKINGS **A-F;J-M** ONLY

N11 - MARKINGS **A-F;J-M**
2121B20 - MARKINGS **G-I**

MARKINGS **G;H,I** ONLY

MARKINGS **A-F;J;L;M** ONLY

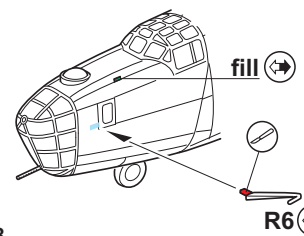
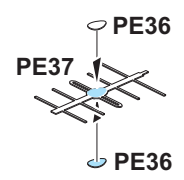

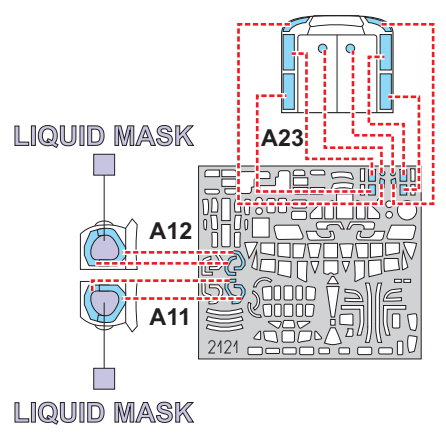
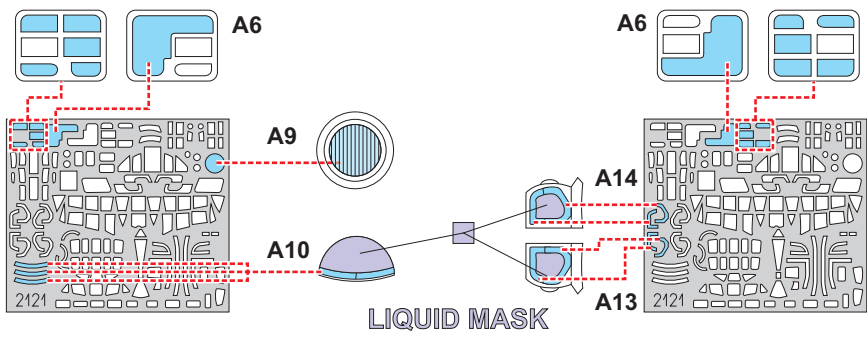
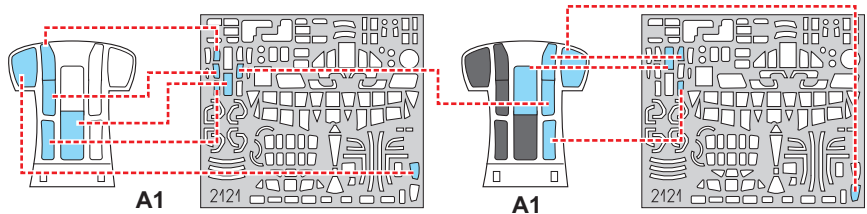
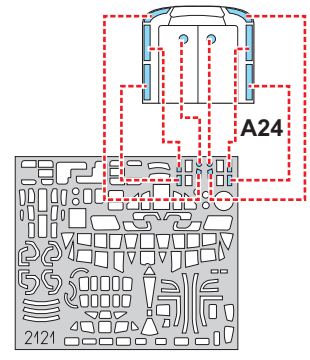
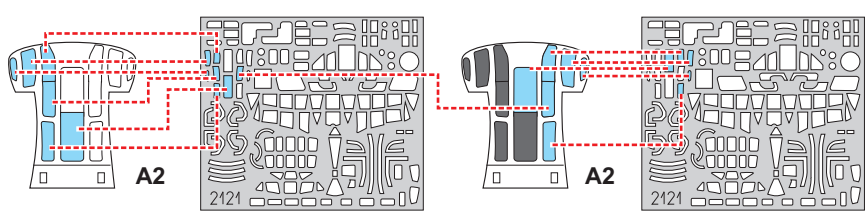
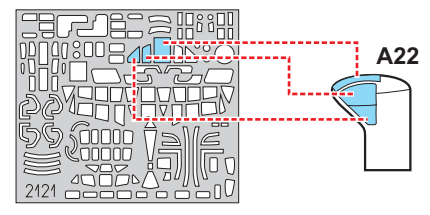
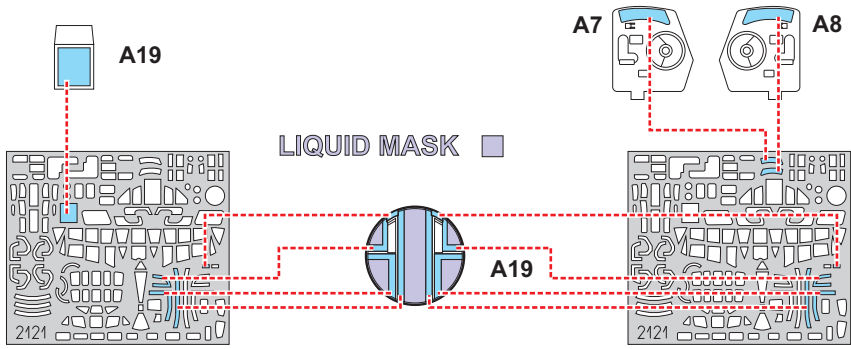
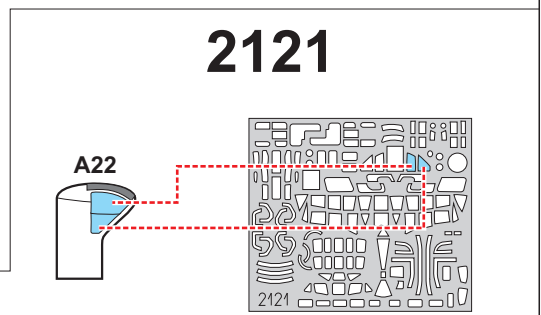
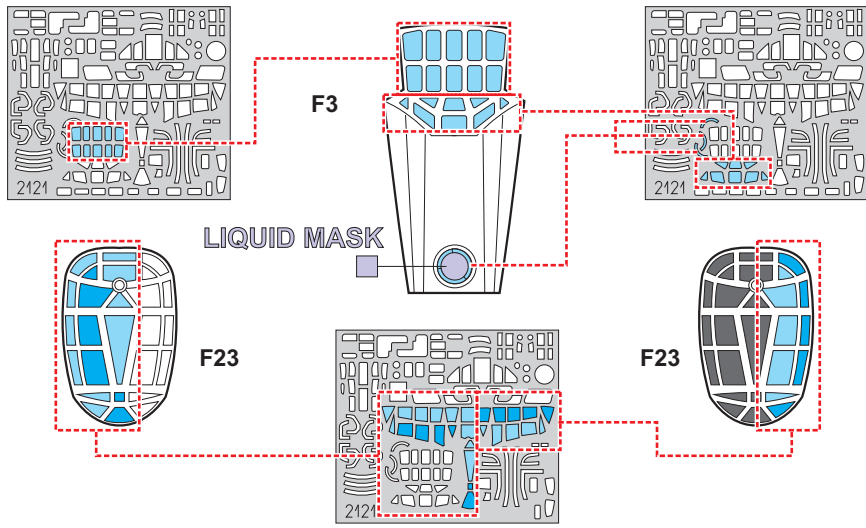
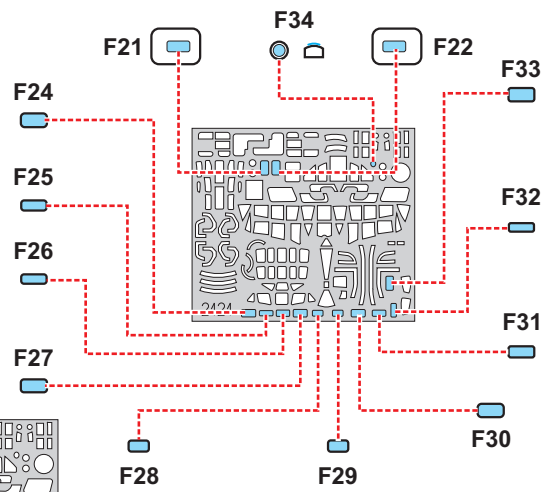
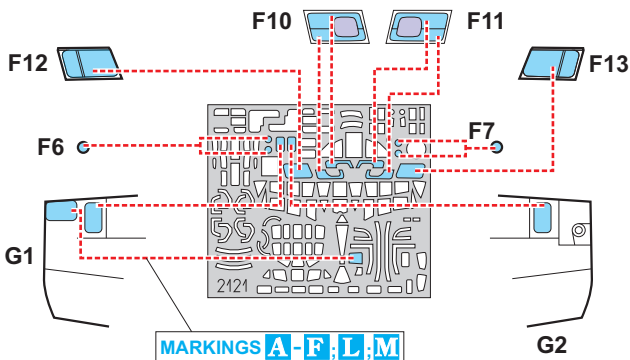

A Liberator GR Mk.V, BZ721, flown by S/Ldr Terence Bulloch, No. 224 Squadron, St. Eval, Great Britain, July 1943

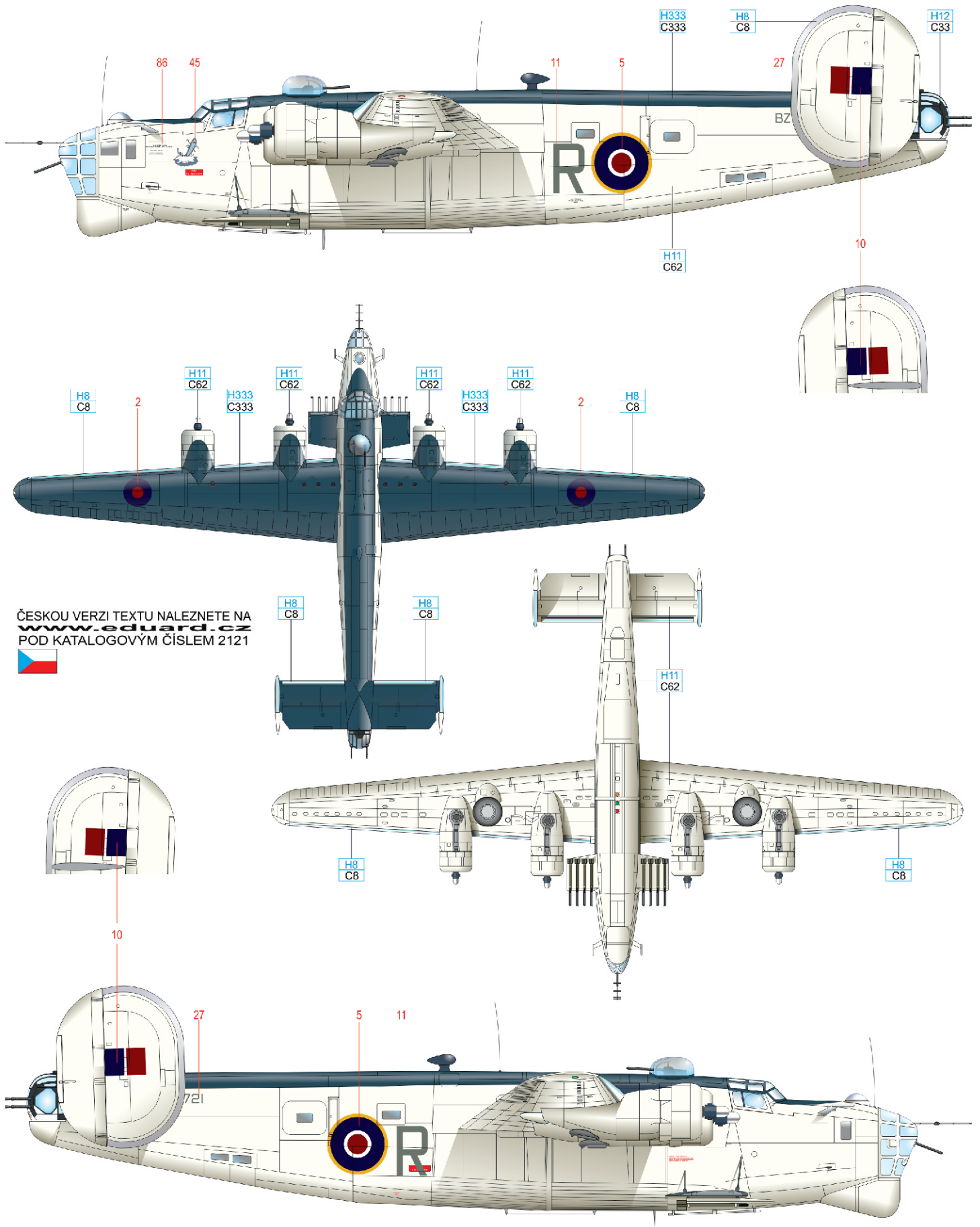

ČESKOU VERZI TEXTU NALEZNETE NA www.eduard.cz POD KATALOGOVÝM ČÍSLEM 2121



BLACK	H12 C33
EXTRA DARK SEA GRAY	H333 C333
WHITE	H11 C62
SILVER	H8 C8

B Liberator GR Mk.V, BZ723, flown by S/Ldr Alois Šedivý, No. 311 Squadron, Tain, Great Britain, October 1944

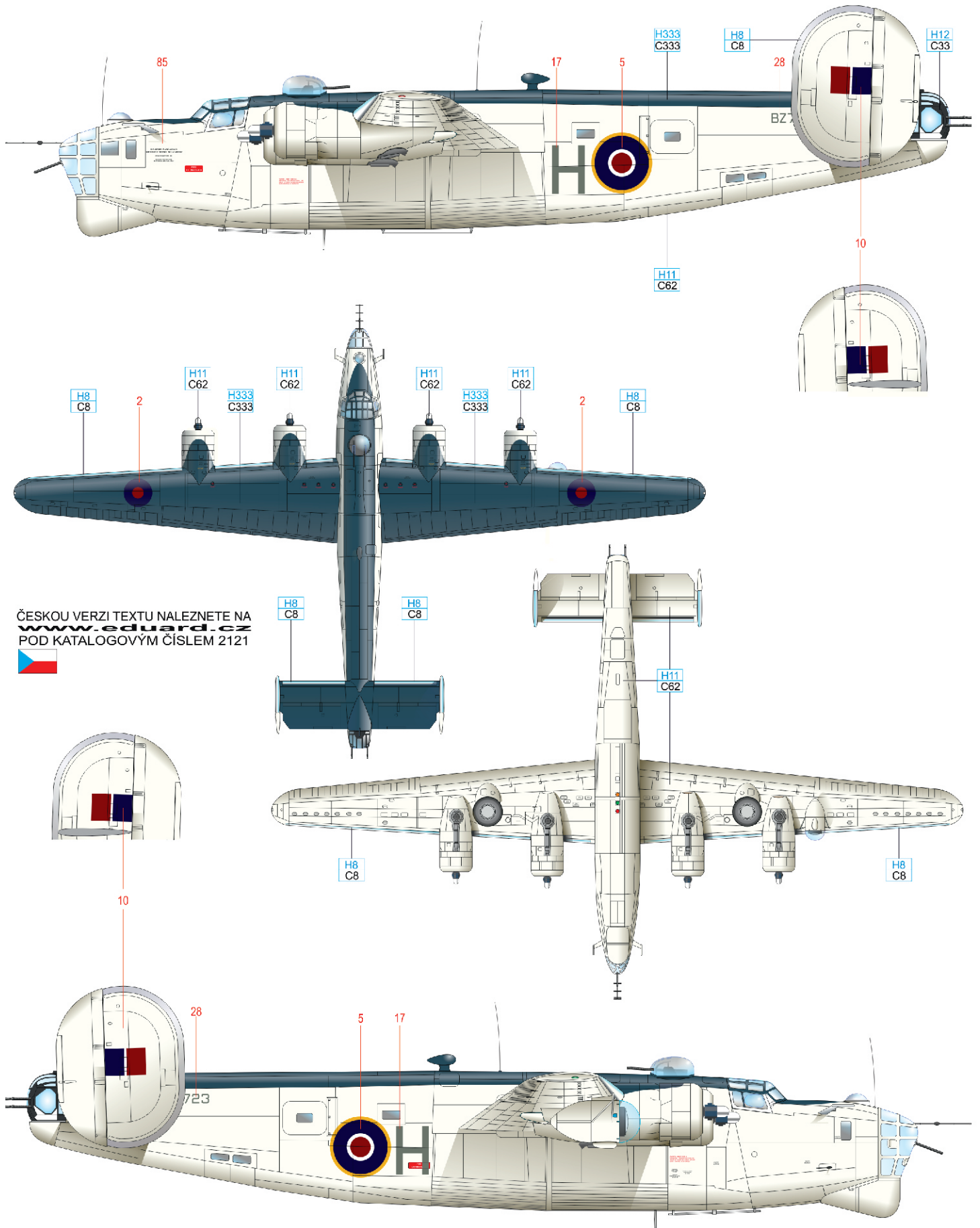

ČESKOU VERZI TEXTU NALEZNETE NA www.eduard.cz POD KATALOGOVÝM ČÍSLEM 2121



BLACK	H12 C33
EXTRA DARK SEA GRAY	H333 C333
WHITE	H11 C62
SILVER	H8 C8

C Liberator GR Mk.V, BZ774, flown by F/Sgt Otakar Žanta, No. 311 Squadron, Beaulieu, Great Britain, Autumn 1943

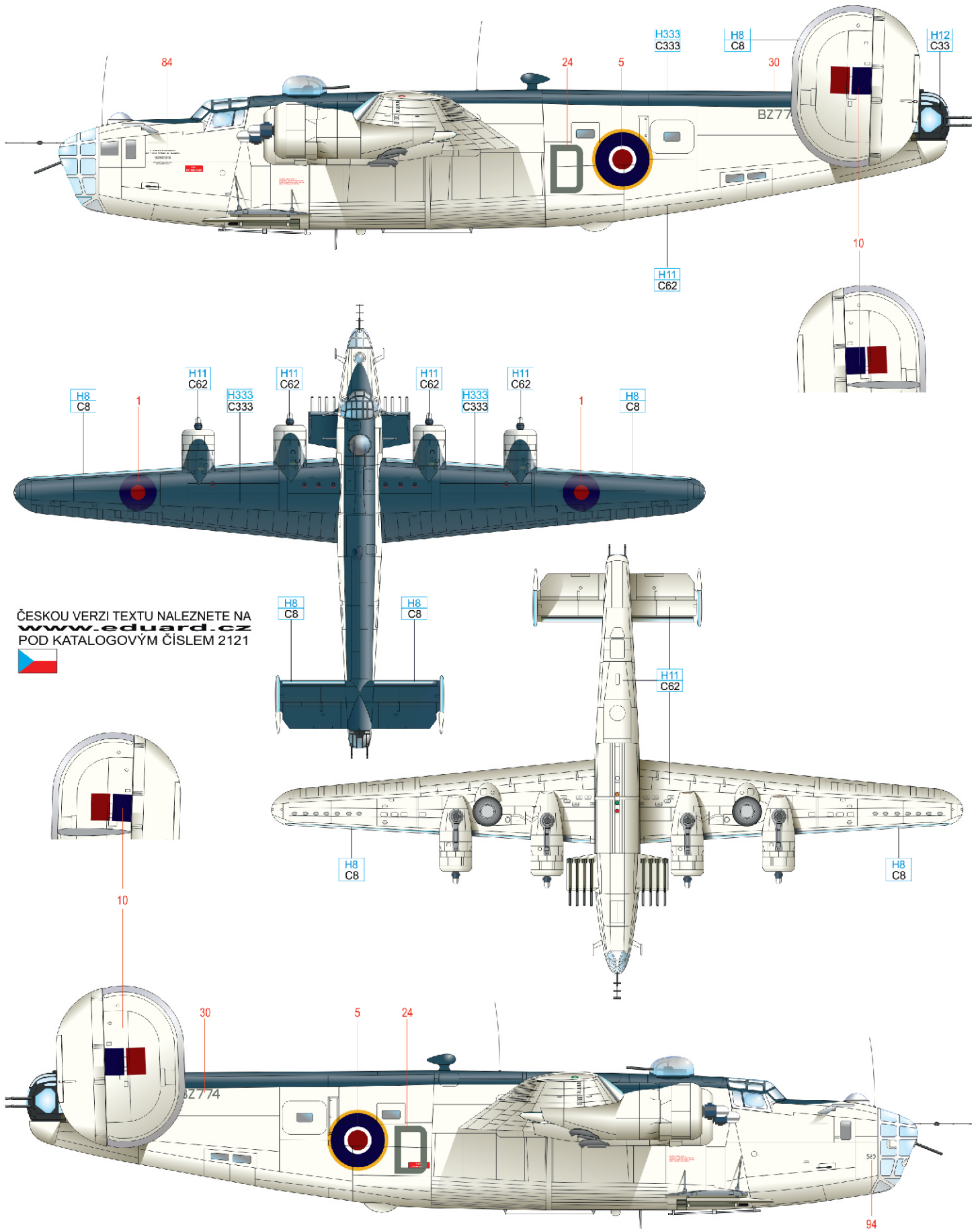

ČESKOU VERZI TEXTU NALEZNETE NA www.eduard.cz POD KATALOGOVÝM ČÍSLEM 2121



BLACK	H12 C33
EXTRA DARK SEA GRAY	H333 C333
WHITE	H11 C62
SILVER	H8 C8

D Liberator GR Mk.V, BZ779, flown by F/Sgt Josef Kuhn, No. 311 Squadron, Beaulieu, Great Britain, October 1943

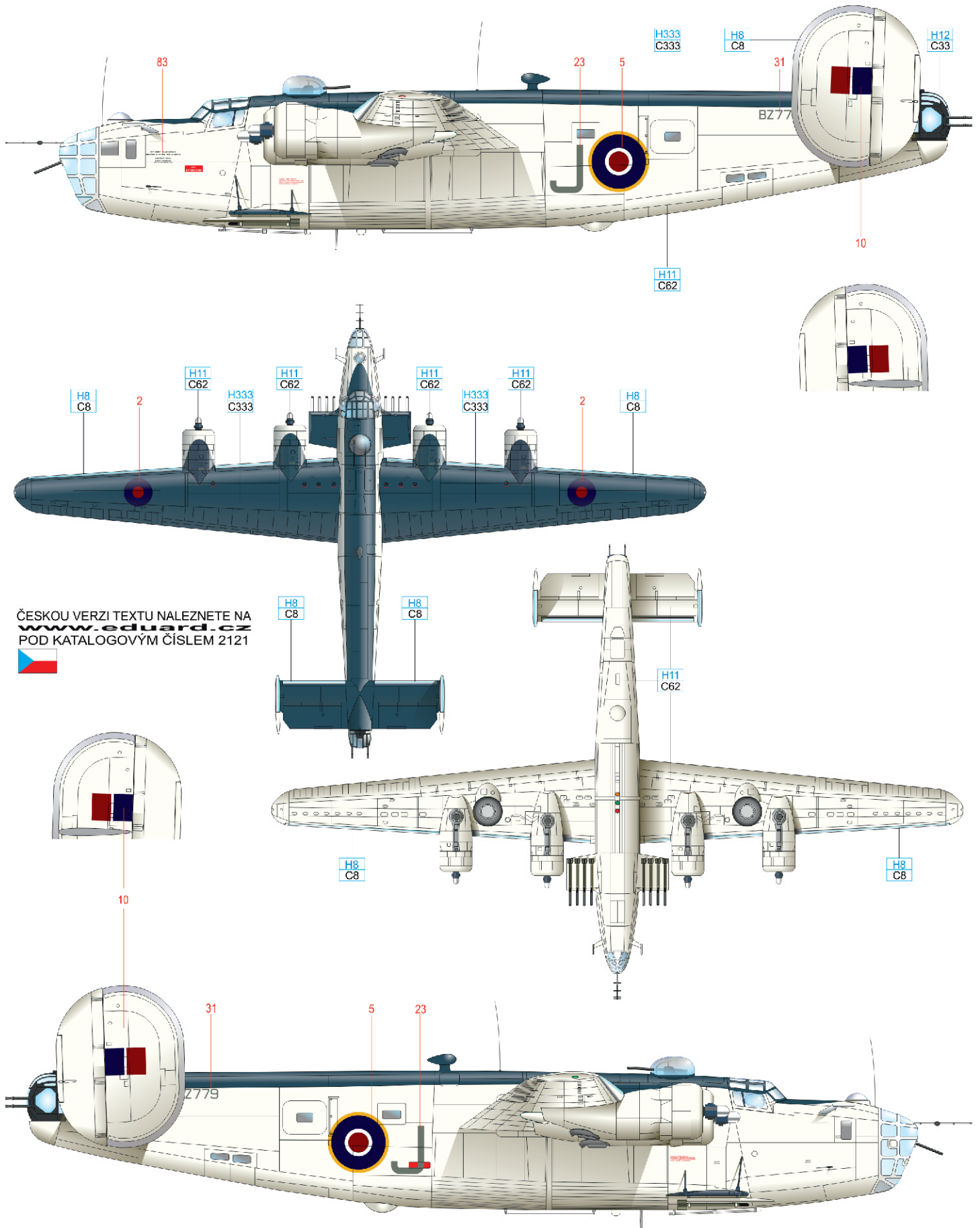

ČESKOU VERZI TEXTU NALEZNETE NA www.eduard.cz POD KATALOGOVÝM ČÍSLEM 2121



BLACK	H12 C33	WHITE	H11 C62	SILVER	H8 C8
EXTRA DARK SEA GRAY	H333 C333				

E Liberator GR Mk.V, BZ786, flown by P/O Jan Irving, No. 311 Squadron, Beaulieu, Great Britain, Autumn 1943

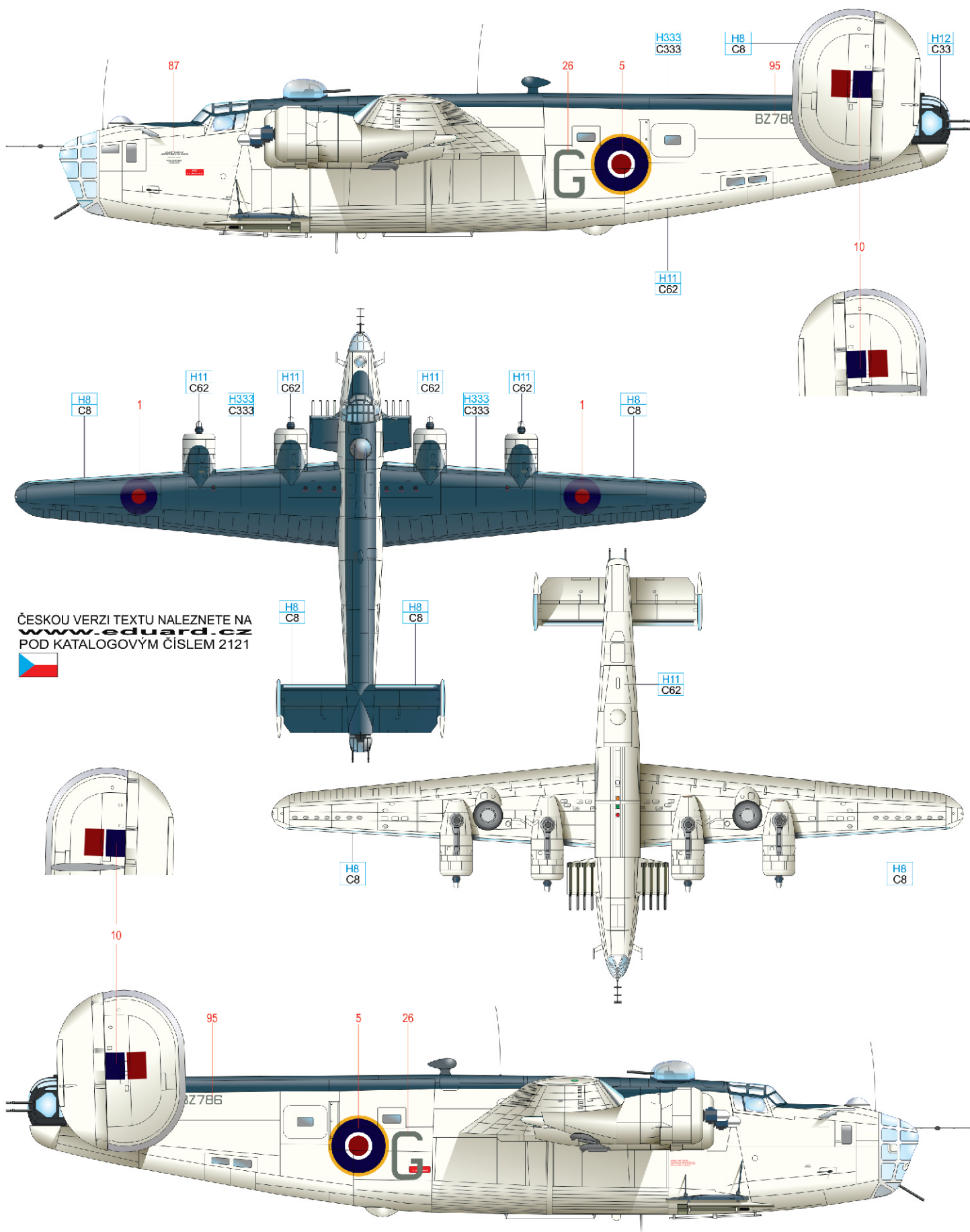

ČESKOU VERZI TEXTU NALEZNETE NA www.eduard.cz POD KATALOGOVÝM ČÍSLEM 2121



BLACK	H12 C33	WHITE	H11 C62	SILVER	H8 C8
EXTRA DARK SEA GRAY	H333 C333				

F Liberator GR Mk.V, BZ796, flown by P/O Oldřich Doležal, No. 311 Squadron, Beaulieu, Great Britain, December 1943

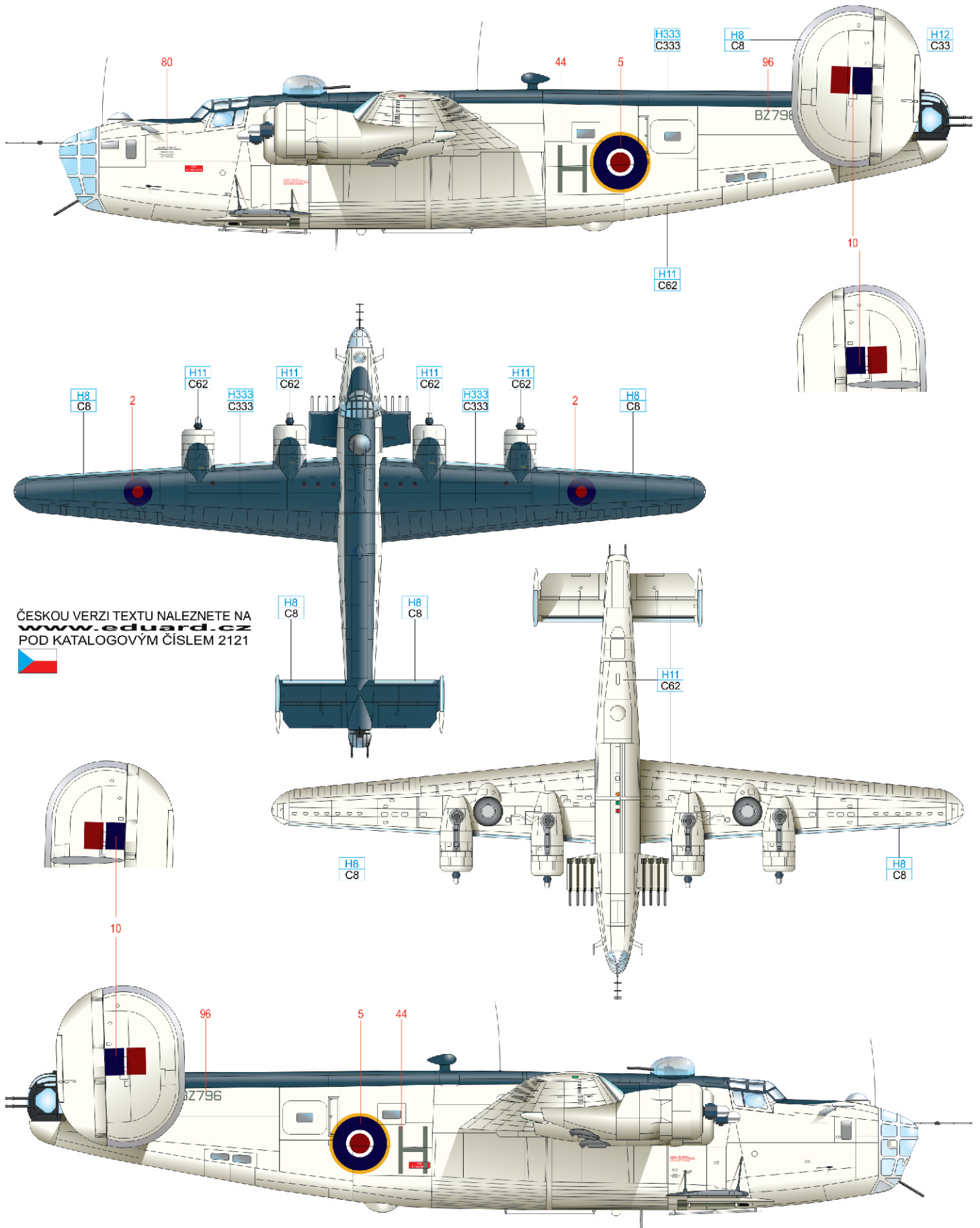

ČESKOU VERZI TEXTU NALEZNETE NA www.eduard.cz POD KATALOGOVÝM ČÍSLEM 2121



BLACK	H12 C33	WHITE	H11 C62	SILVER	H8 C8
EXTRA DARK SEA GRAY	H333 C333				

G Liberator GR Mk.V, FL961, flown by F/O Jan Vella, No. 311 Squadron, Predannack, Great Britain, June 1944

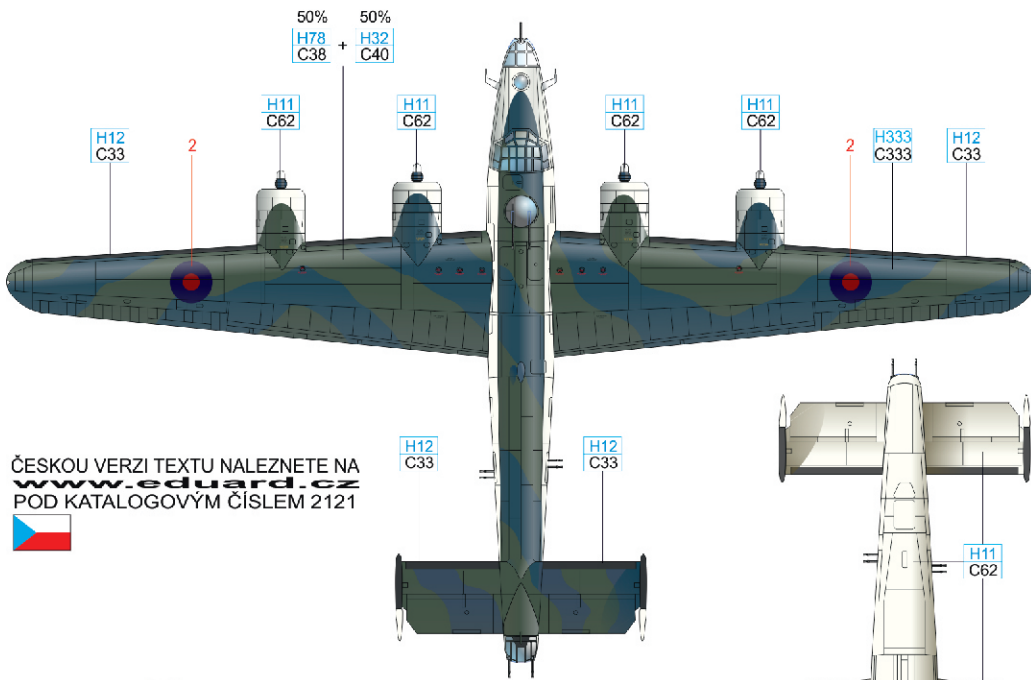
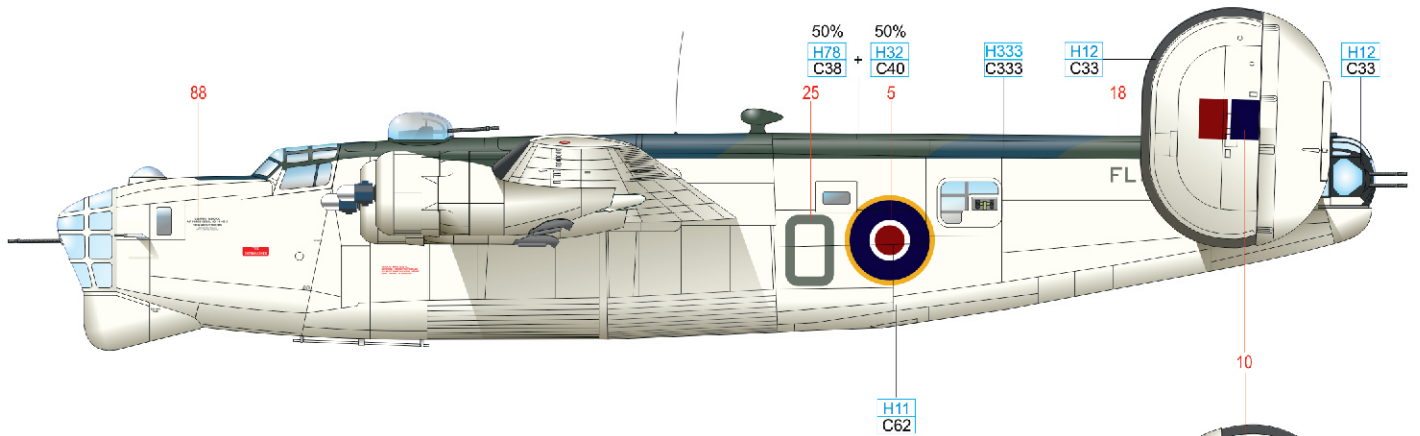

ČESKOU VERZI TEXTU NALEZNETE NA www.eduard.cz POD KATALOGOVÝM ČÍSLEM 2121

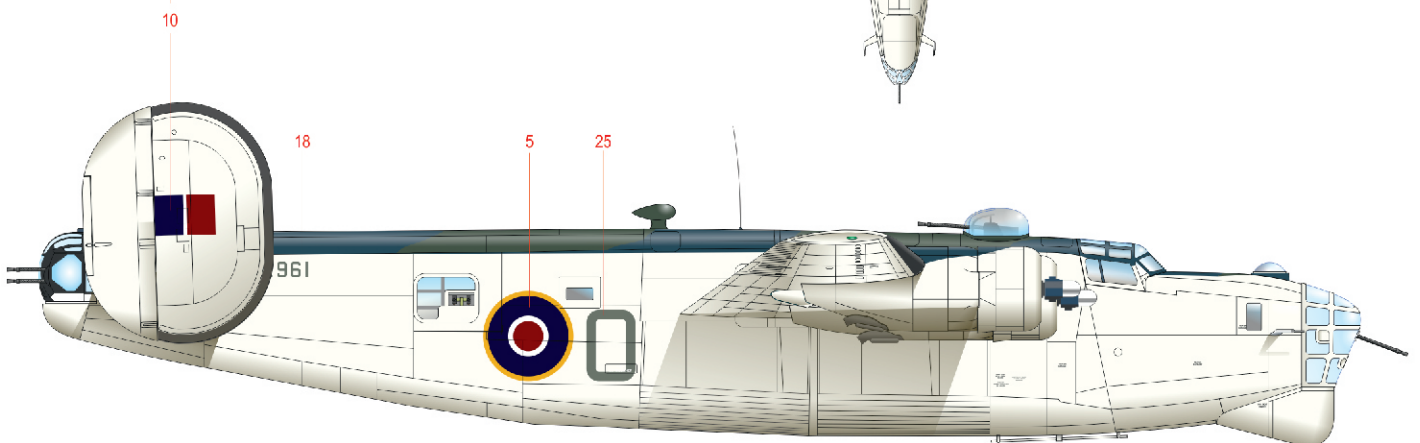
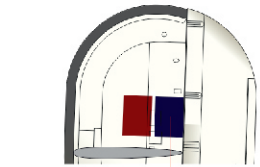
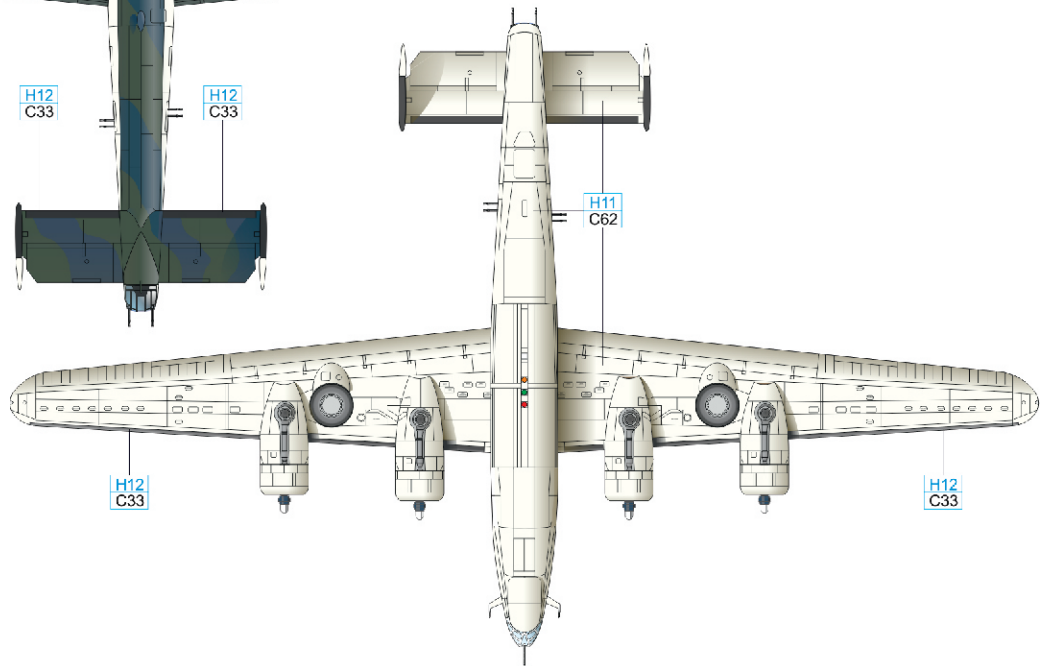

50% DARK SLATE GRAY	H78 C38	+	50% H32 C40	
EXTRA DARK SEA GRAY	H333 C333	WHITE	H11 C62	BLACK H12 C33

H Liberator GR Mk.V, FL949, flown by F/O Josef Pavelka, No. 311 Squadron, Tain, Great Britain, October 1944

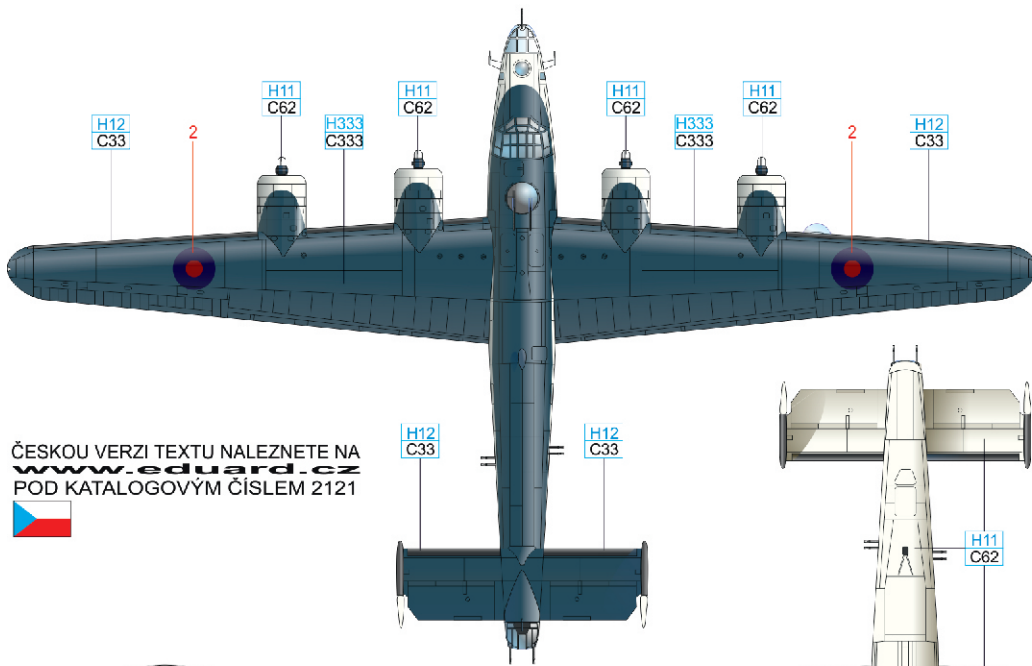
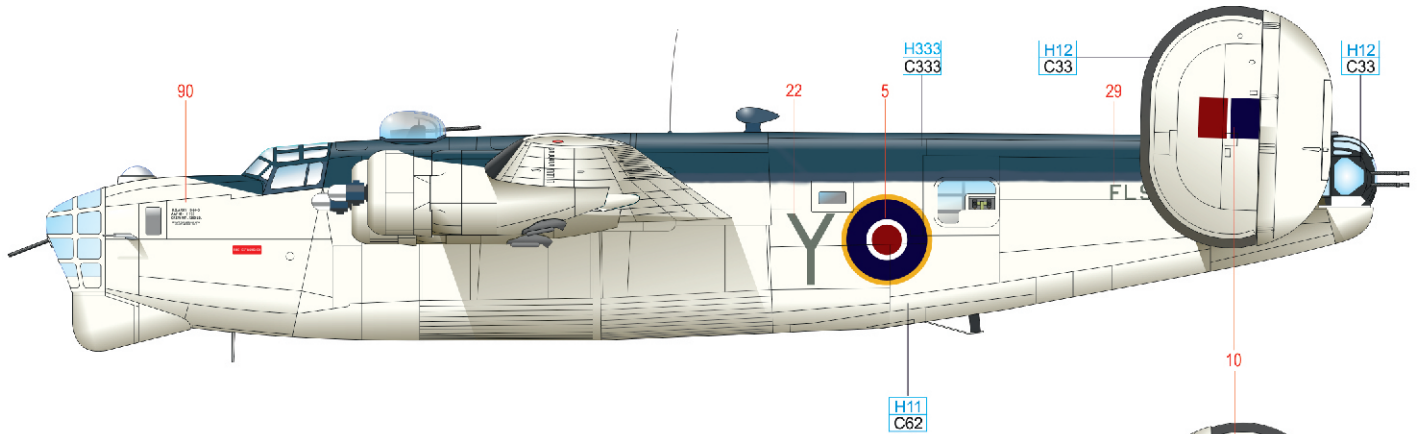

ČESKOU VERZI TEXTU NALEZNETE NA www.eduard.cz POD KATALOGOVÝM ČÍSLEM 2121

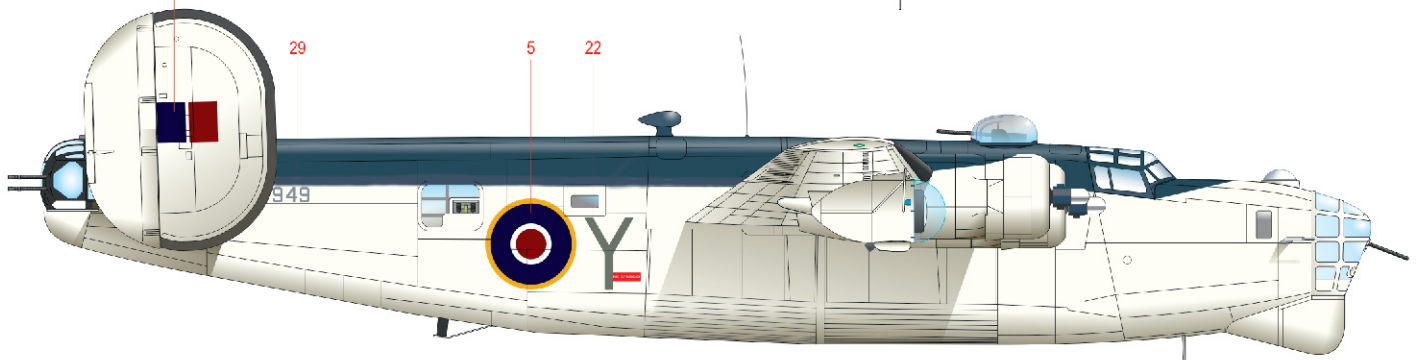
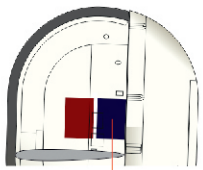
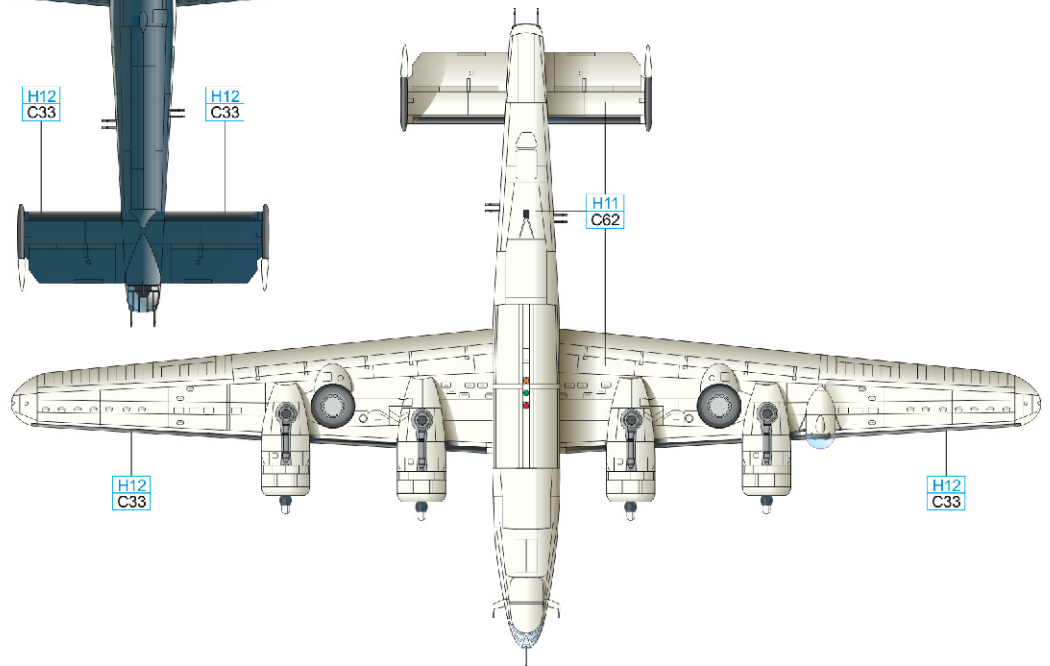

EXTRA DARK H333
SEA GRAY C333

WHITE H11
C62

BLACK H12
C33

Liberator GR Mk.III, FL936, flown by P/O Ben Hall, No. 160 Squadron, Sigiriya, Ceylon, Autumn 1943

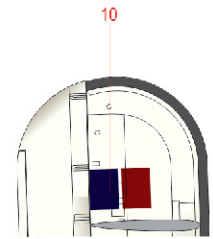
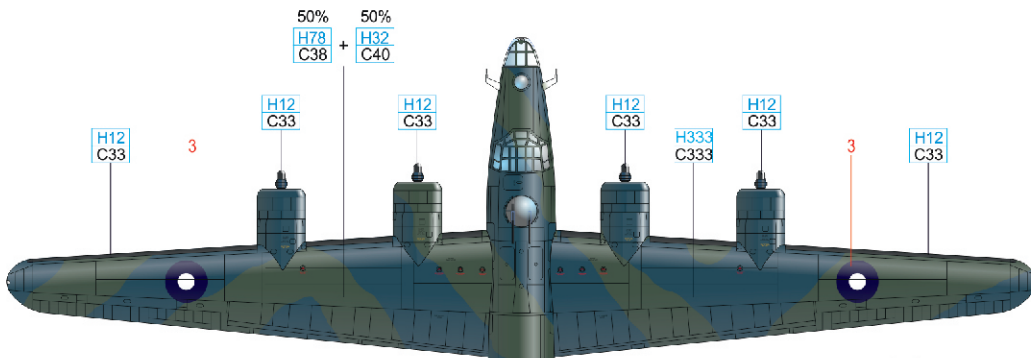
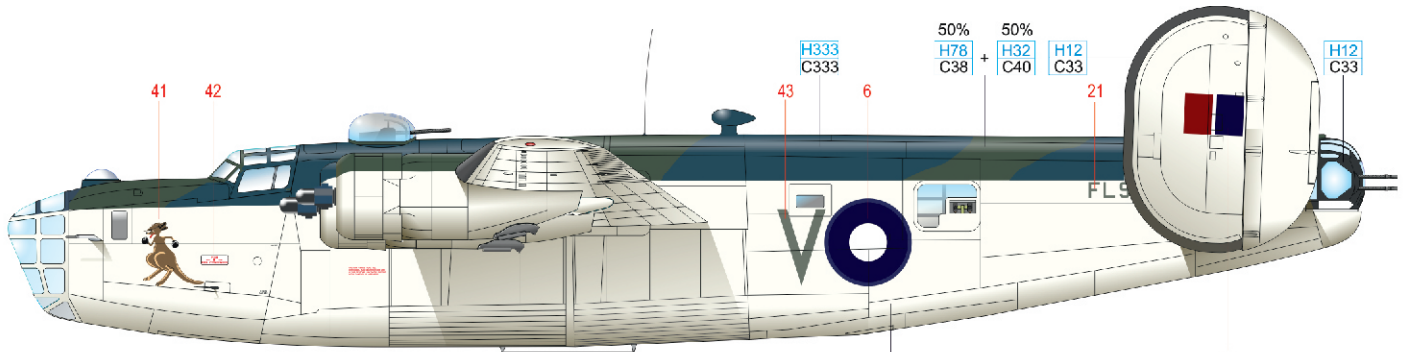

ČESKOU VERZI TEXTU NALEZNETE NA www.eduard.cz POD KATALOGOVÝM ČÍSLEM 2121

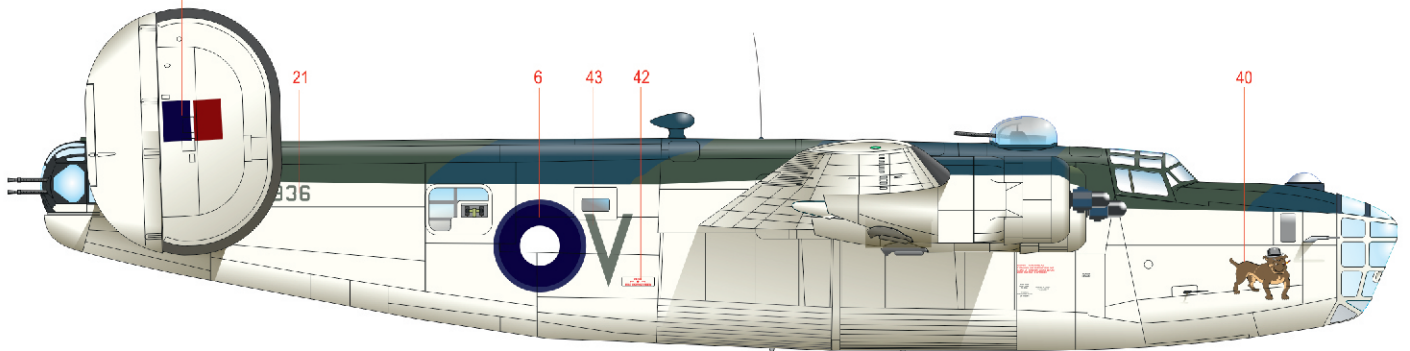
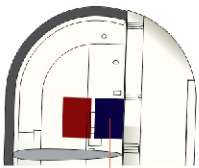
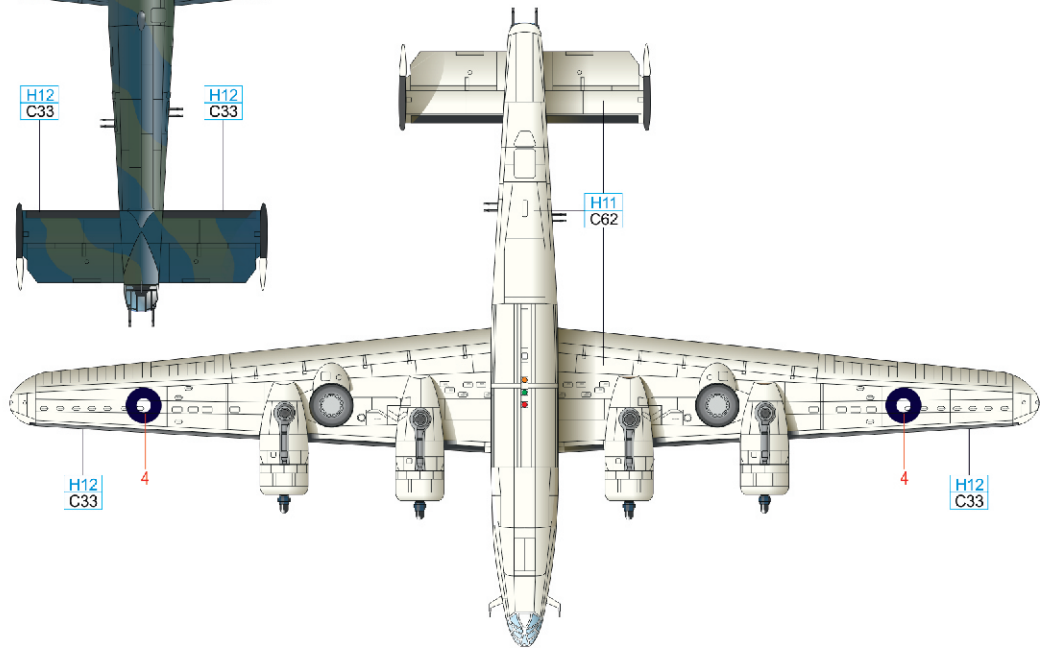

50% DARK SLATE GRAY	H78 C38	+	50% H32 C40			
EXTRA DARK SEA GRAY	H333 C333		WHITE	H11 C62	BLACK	H12 C33

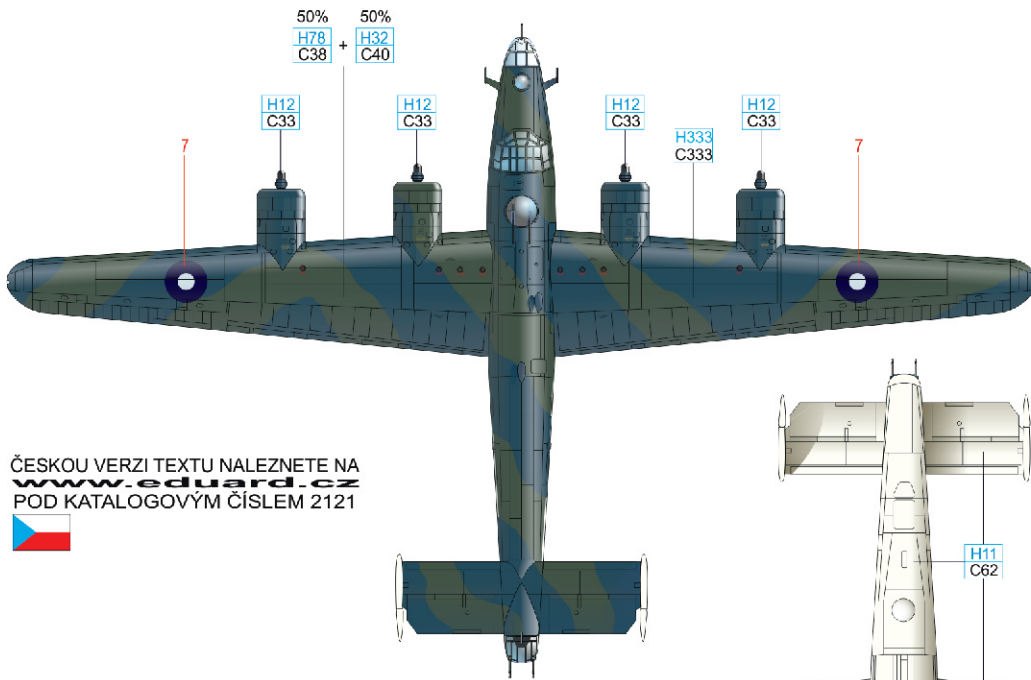
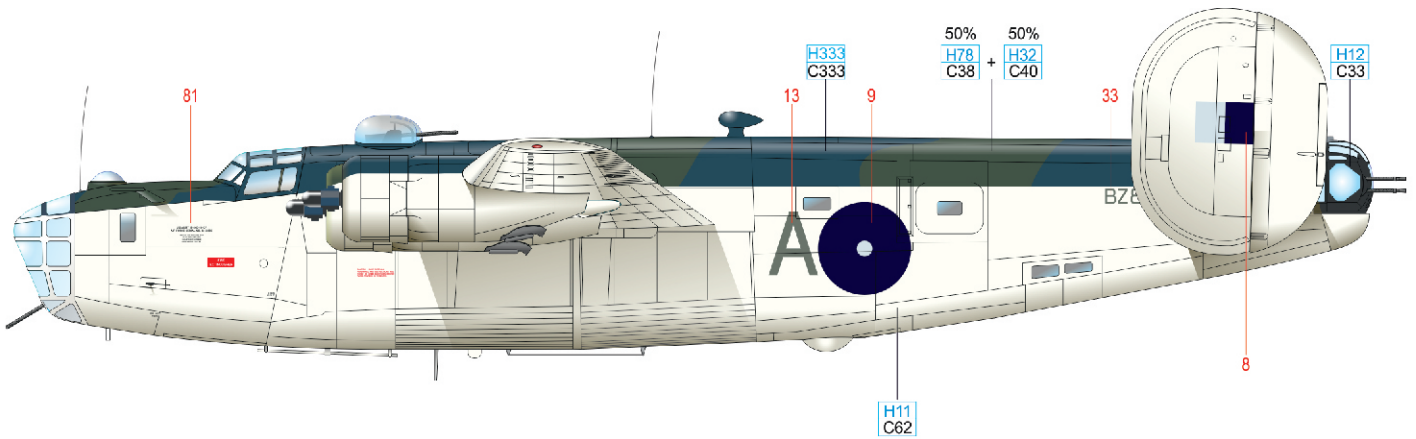

ČESKOU VERZI TEXTU NALEZNETE NA www.eduard.cz POD KATALOGOVÝM ČÍSLEM 2121

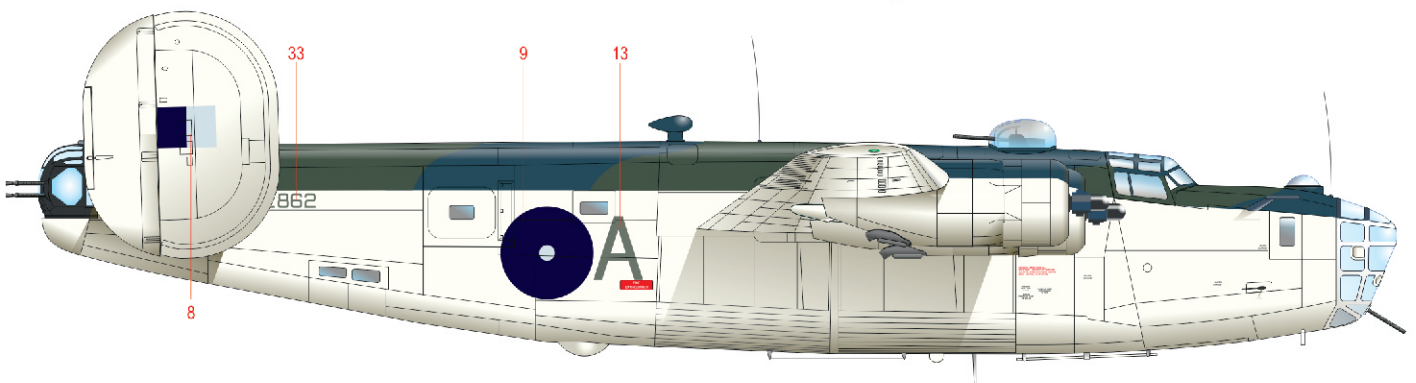
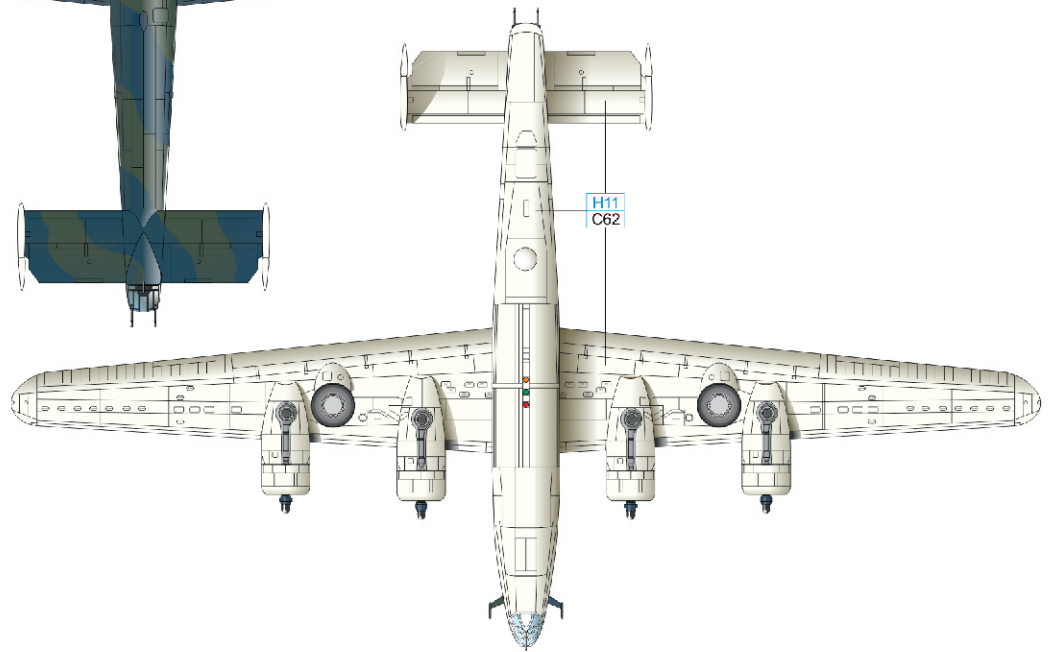

50% DARK SLATE GRAY	H78 C38	+	50% H32 C40	
EXTRA DARK SEA GRAY	H333 C333	WHITE	H11 C62	BLACK H12 C33

Liberator GR Mk.V, BZ755, flown by F/O A. Cirko, No. 10 (BR) Squadron RCAF, Gander, Canada, Autumn 1943

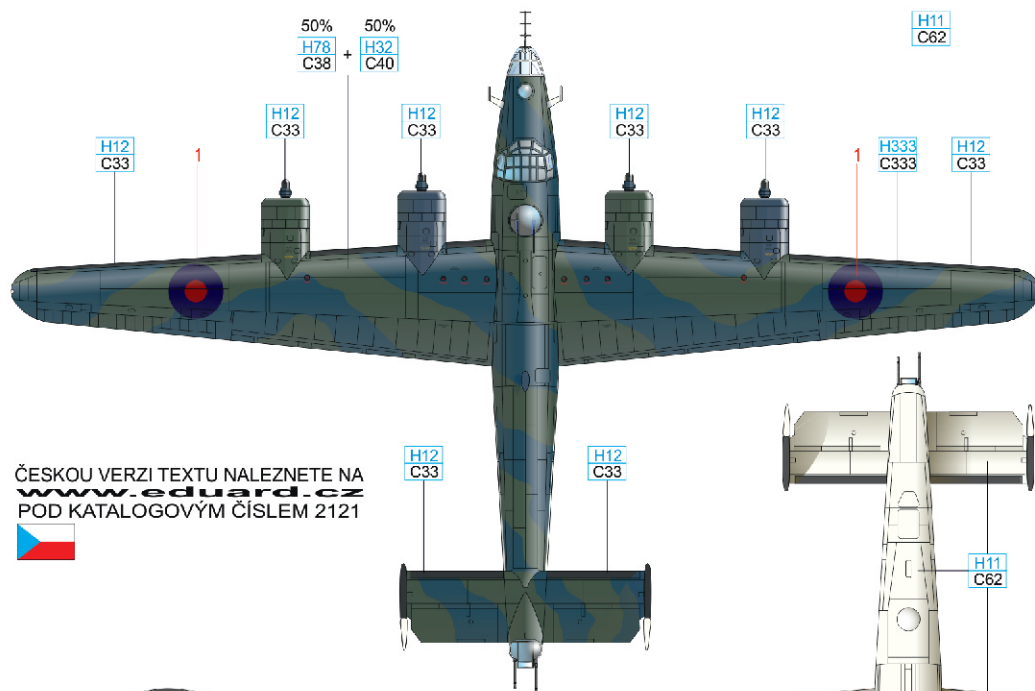
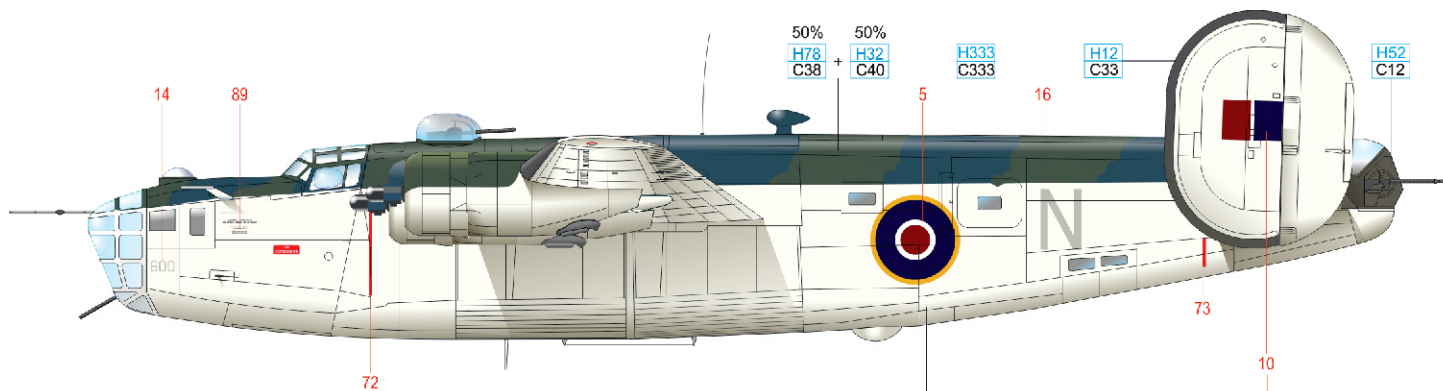

ČESKOU VERZI TEXTU NALEZNETE NA www.eduard.cz POD KATALOGOVÝM ČÍSLEM 2121

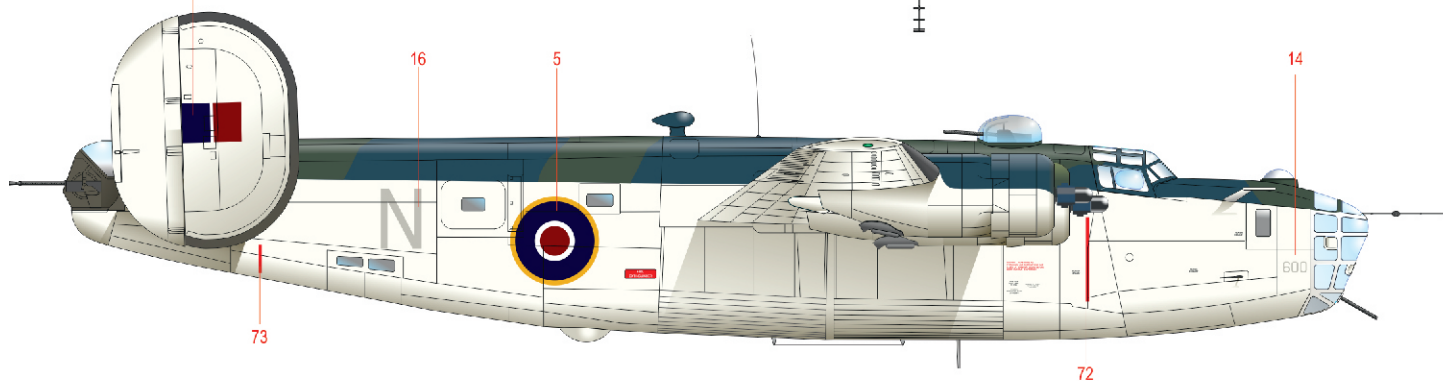
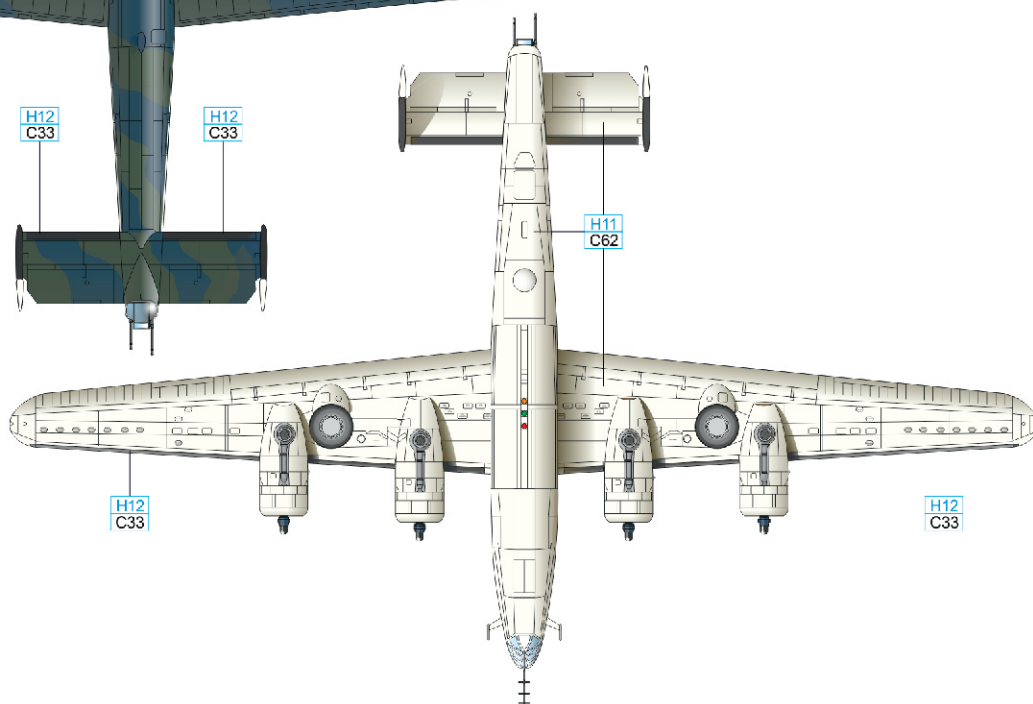

OLIVE DRAB	H52 C12	50% DARK SLATE GRAY	H78 C38	+	50% H32 C40
EXTRA DARK SEA GRAY	H333 C333	WHITE	H11 C62	BLACK	H12 C33

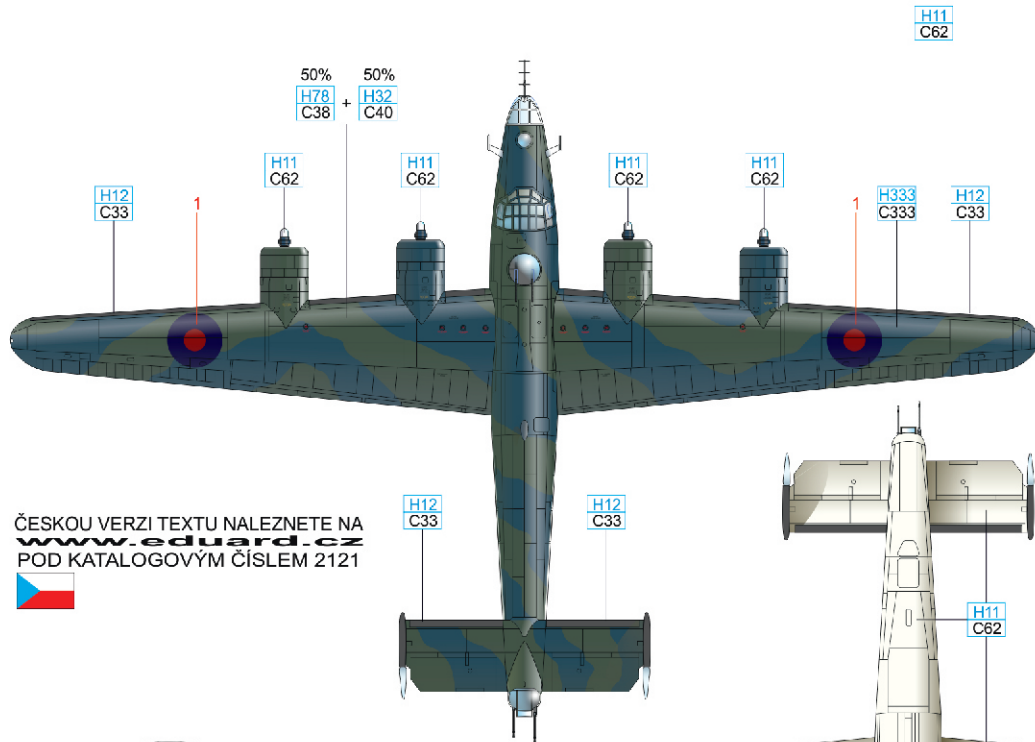
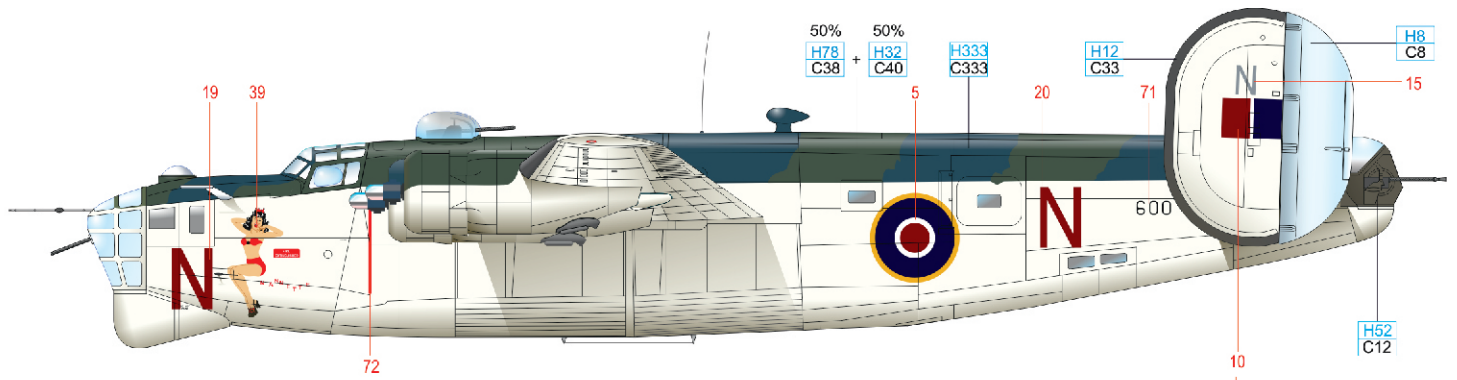

ČESKOU VERZI TEXTU NALEZNETE NA www.eduard.cz POD KATALOGOVÝM ČÍSLEM 2121

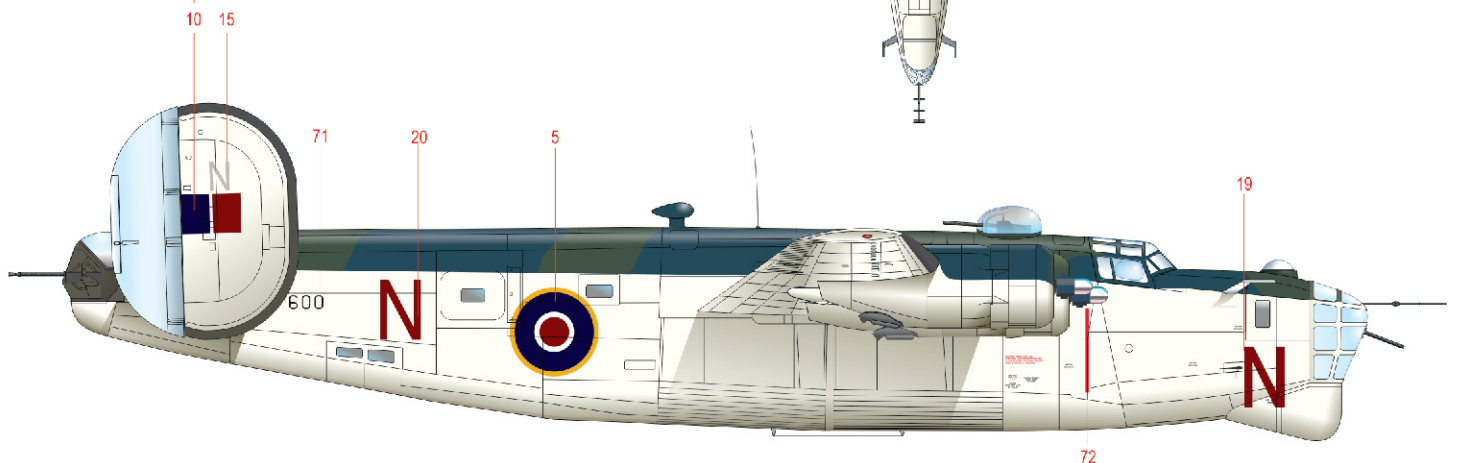
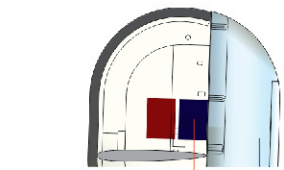
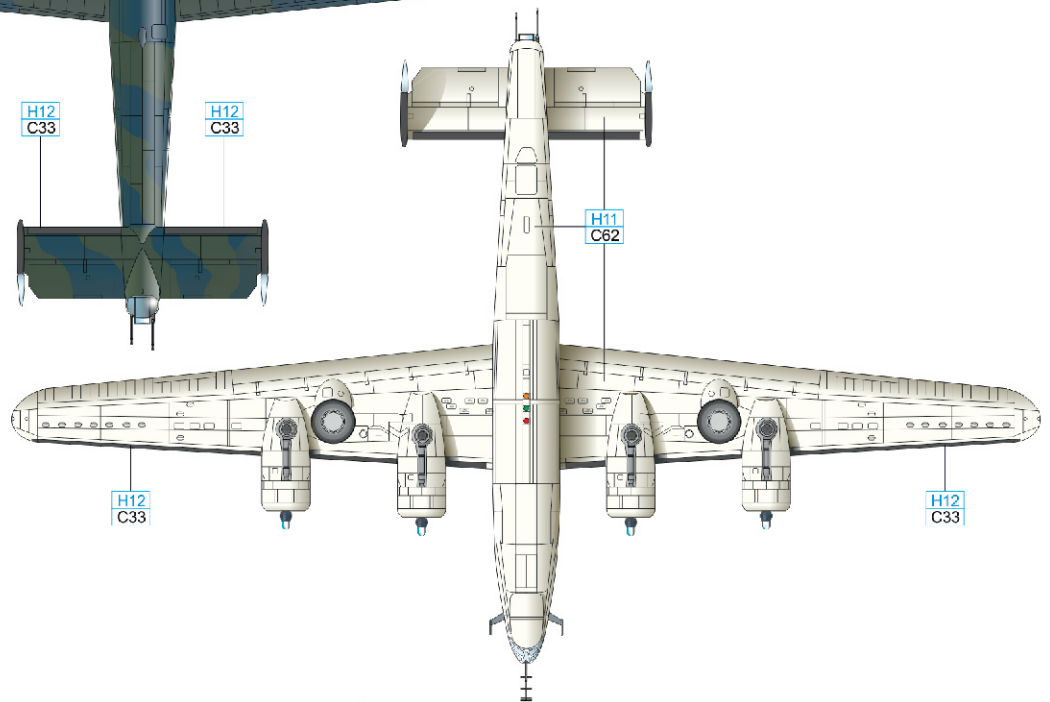

OLIVE DRAB	H52 C12	50% DARK SLATE GRAY	H78 C38	+	50% H32 C40	WHITE	H11 C62	BLACK	H12 C33	SILVER	H8 C8
EXTRA DARK SEA GRAY	H333 C333										

