

eduard

Limitovaná edice

Kuňkadlo

1/72



Stavební návod
Instruction sheet

Z180 - nav1

ATTENTION



UPOZORNĚNÍ



ACHTUNG



ATTENTION



注意



Carefully read instruction sheet before assembling. When you use glue or paint, do not use near open flame and use in well ventilated room. Keep out of reach of small children. Children must not be allowed to suck any part, or pull vinyl bag over the head.



Před započítím stavby si pečlivě prostudujte stavební návod. Při používání barev a lepidel pracujte v době větrané místnosti. Lepidla ani barvy nepoužívejte v blízkosti otevřeného ohně. Model není určen malým dětem, mohlo by dojít k požití drobných dílů.

INSTRUCTION SIGNS

* INSTR. SYMBOLY

* INSTRUKTION

* SINNBILDEN

* SYMBOLES

* 記号の説明

OPTIONAL
VOLBABEND
OHNOUTSAND
BROUSITOPEN HOLE
VYVRTAT OTVORSYMMETRICAL ASSEMBLY
SYMETRICKÁ MONTÁŽREMOVE
ODRŽNOUTREVERSE SIDE
OTOČITAPPLY EDUARD MASK
AND PAINT
POUŽIT EDUARD MASK
NABARVIT

PARTS



DÍLY



TEILE



PIÈCES



部品

PLASTIC PARTS

A>

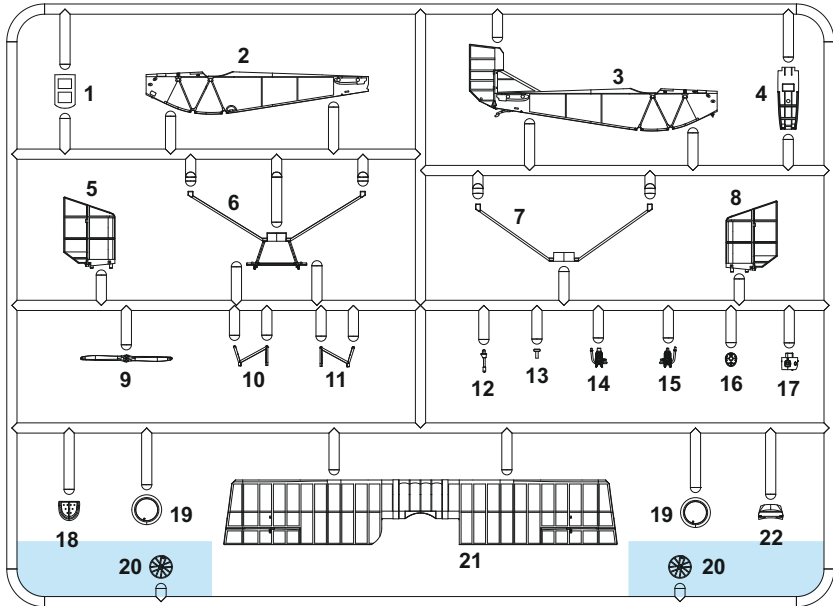
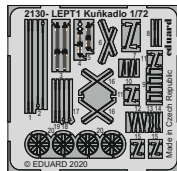
PE - PHOTO ETCHED
DETAIL PARTS

FILM



-Parts not for use. -Teile werden nicht verwendet. -Pièces à ne pas utiliser. -Tyto díly nepoužívejte při stavbě. - 使用しない部品

COLOURS



BARVY



FARBEN



PEINTURE



色

GSI Creos (GUNZE)		MISSION MODELS	
AQUEOUS	Mr.COLOR	PAINTS	
[H8]	[C8]		SILVER
[H37]	[C43]		WOOD BROWN
[H47]	[C41]	[MMP-012]	RED BROWN
[H77]	[C137]	[MMP-040]	TIRE BLACK
[H85]	[C45]		SAIL COLOR

Mr.METAL COLOR		METALLICS	
[MC214]		[MMM-001]	DARK IRON
[MC218]		[MMM-003]	ALUMINIUM
Mr.COLOR GX		METALLICS	
[GX03]			HERMANN RED
[GX04]			CHIARA YELLOW

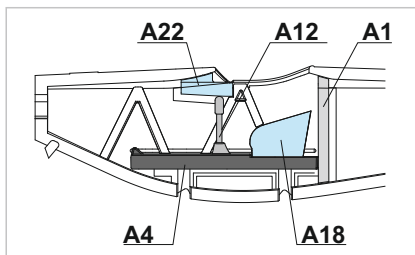
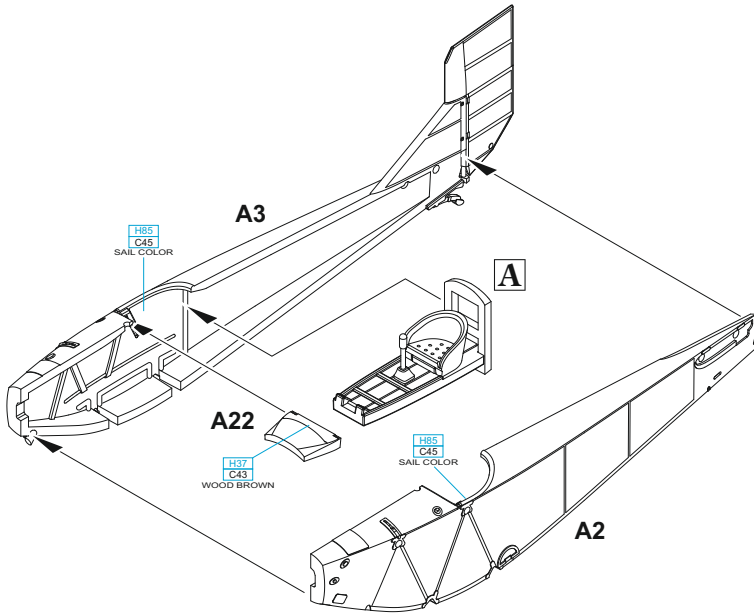
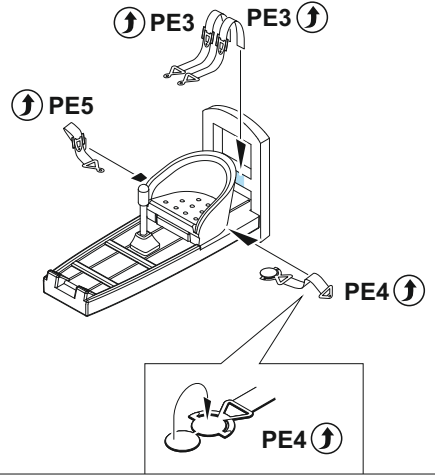
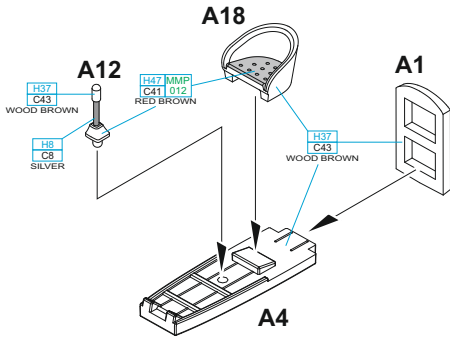
A

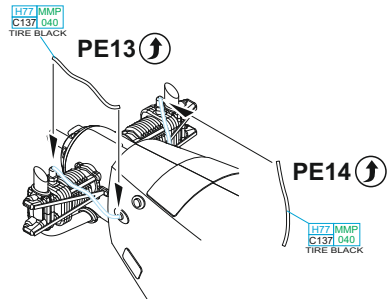
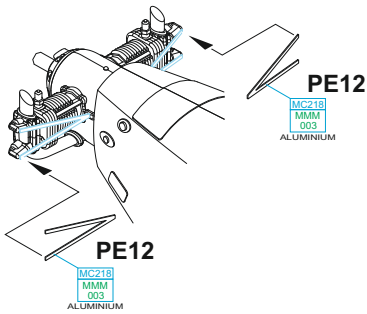
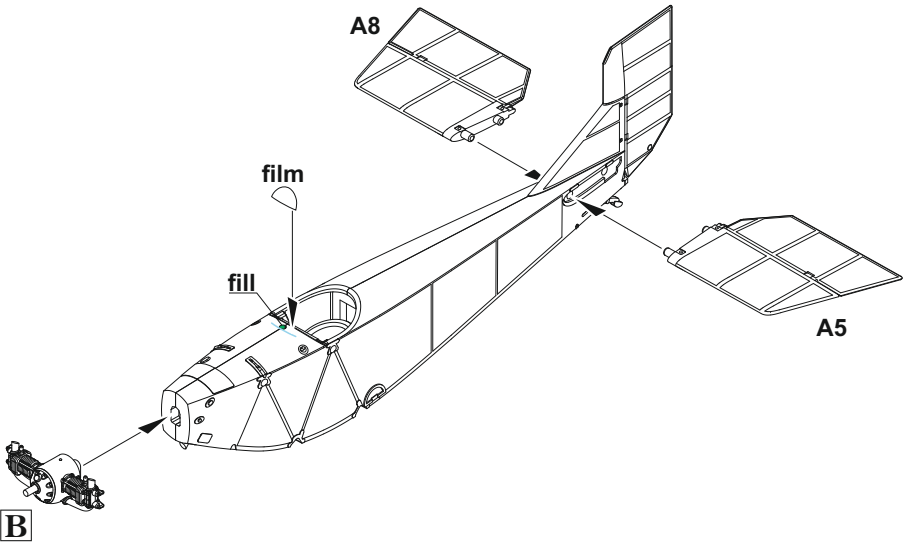
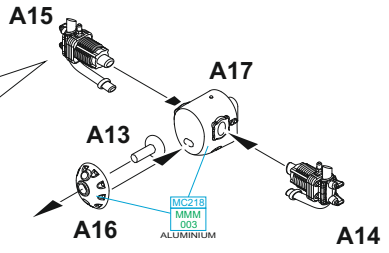
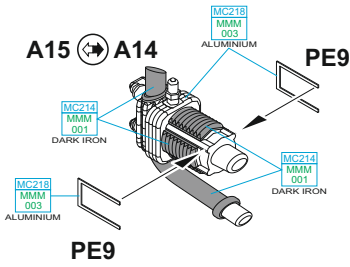

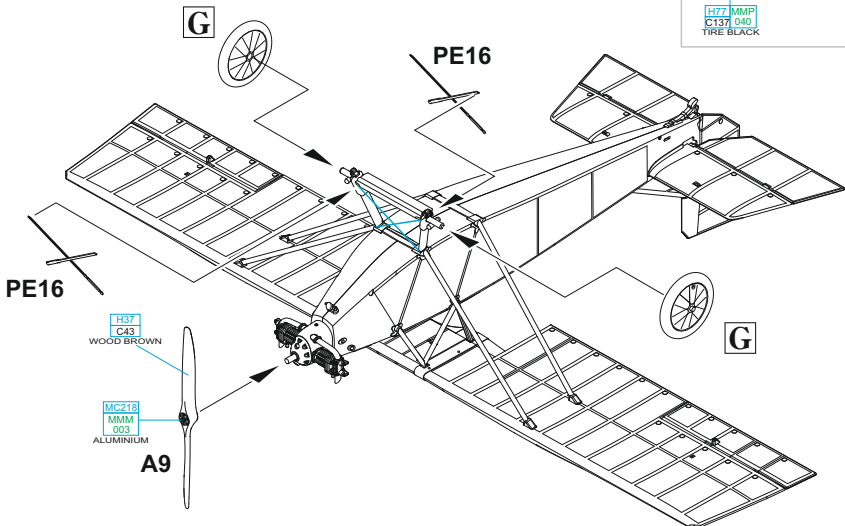
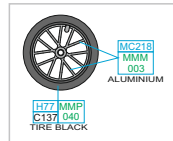
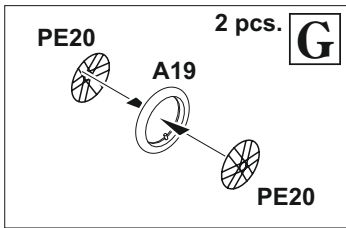
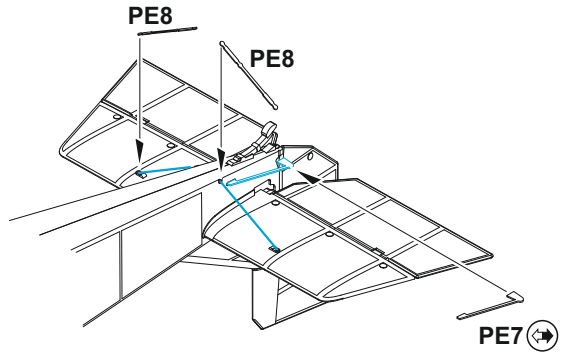
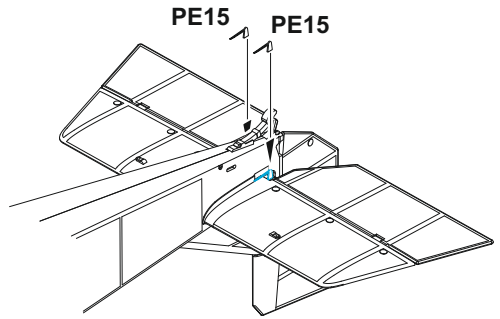
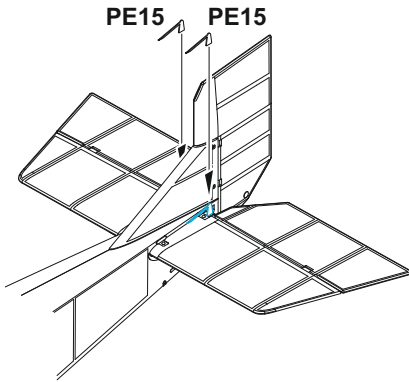

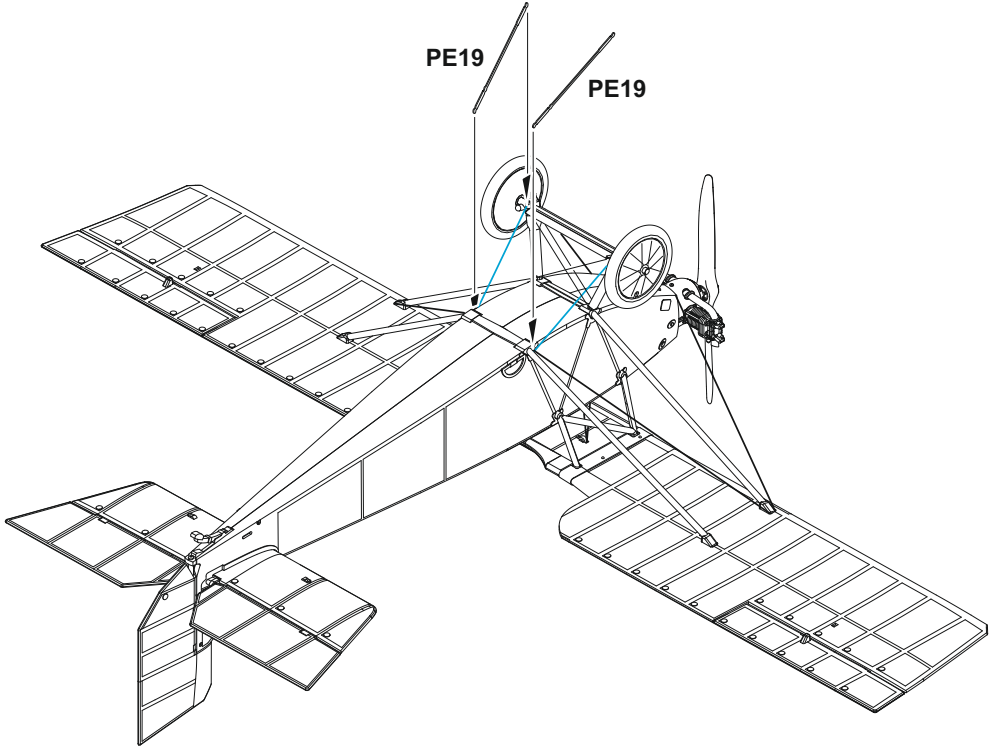
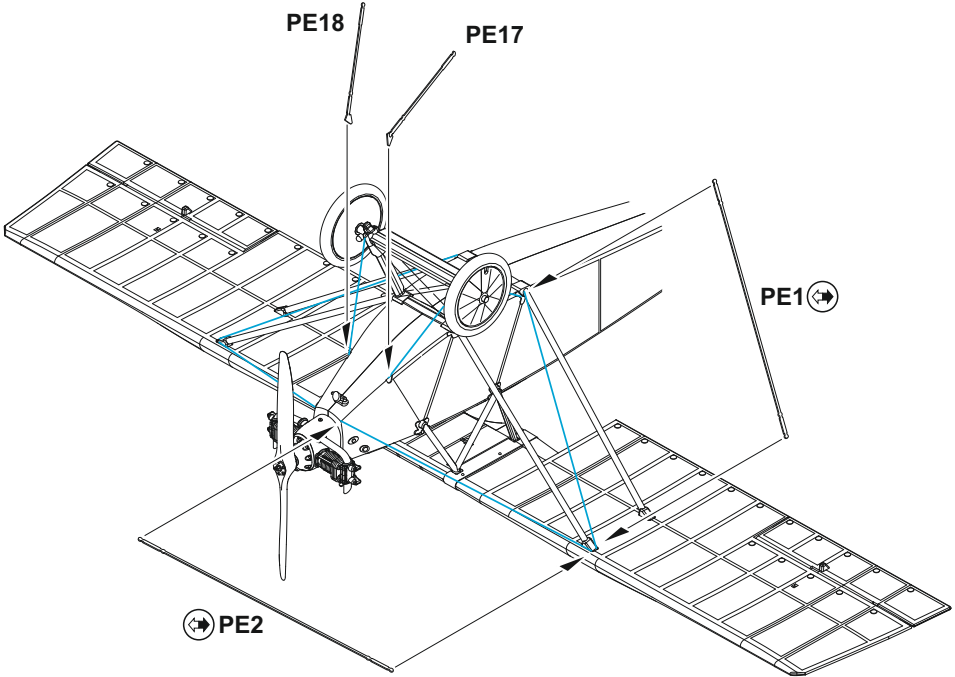

VBSH Kunkadlo, National Technical Museum, Prague, 1967 to the Present Day

Construction of the Kunkadlo was begun by the brothers Bohuslav and Vladimir Simunek in 1926. The aircraft was completed and flown a year later. The initial flight was conducted by Major Skala, who would become known as a member of a later long distance flight from Prague to Tokyo. After the first flight, the wing position was changed in that it was raised above the fuselage and moved slightly aft. Vladimir Simunek took part in several air shows with this sport plane. The flying career of this noteworthy and unique aircraft ended in 1930, when issues began to arise with its glued construction. The airplane was restored in 1967, with the brothers themselves acting as advisers. After the restoration was complete, the aircraft was hung in the Technical Museum in Prague, where it is displayed to this day.

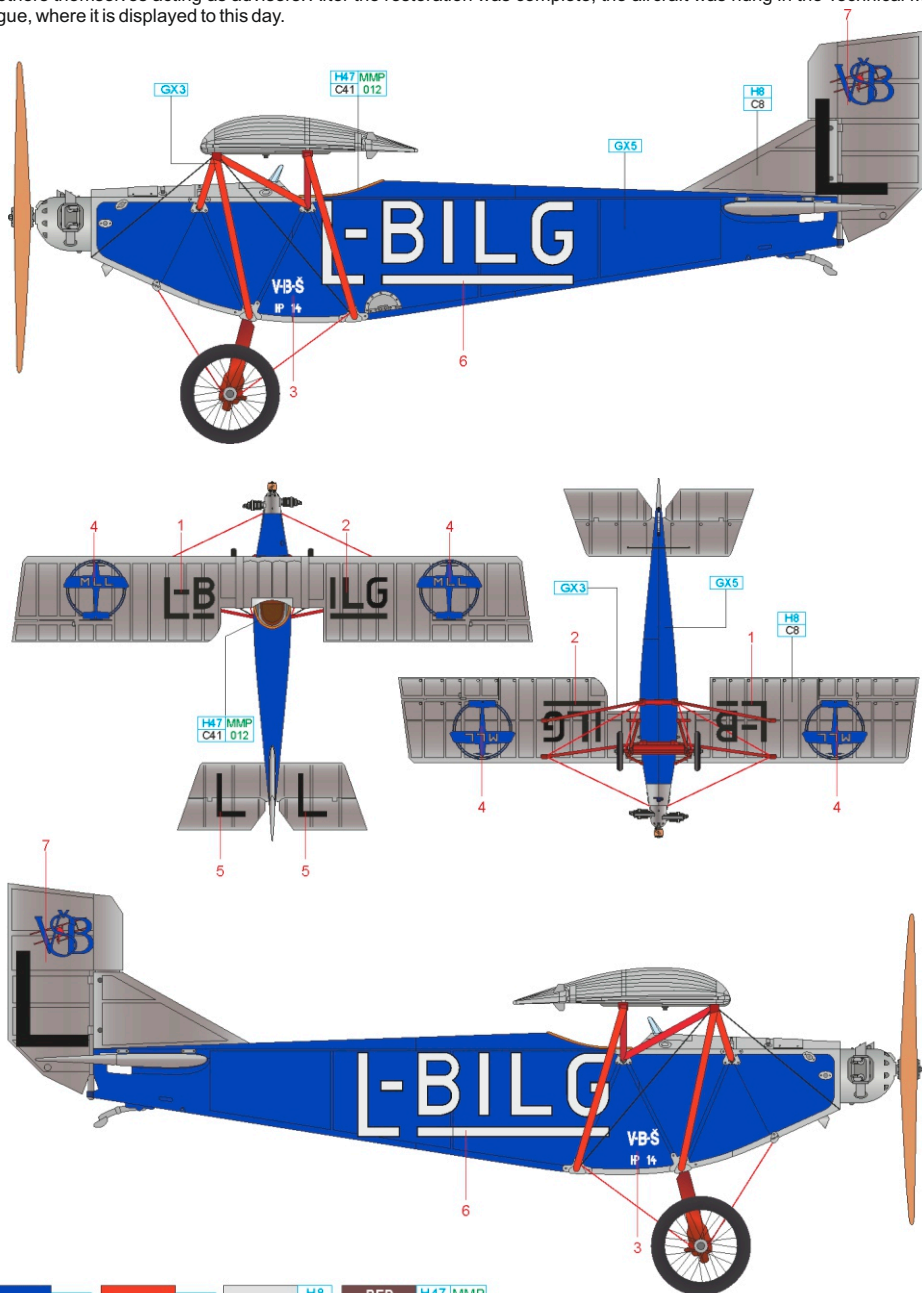

BLUE	GX5	RED	GX3	SILVER	H8 C8	RED BROWN	H47 MMP C41 012
------	-----	-----	-----	--------	-------	-----------	-----------------

eduard