

eduard

LIMITED EDITION



INSTRUCTION SHEET



Desert Babes

1/72

ATTENTION



UPOZORNĚNÍ



ACHTUNG



ATTENTION



注意



Carefully read instruction sheet before assembling. When you use glue or paint, do not use near open flame and use in well ventilated room. Keep out of reach of small children. Children must not be allowed to suck any part, or pull vinyl bag over the head.



Před započítím stavby si pečlivě prostudujte stavební návod. Při používání barev a lepidel pracujte v dobře větrané místnosti. Lepidla ani barvy nepoužívejte v blízkosti otevřeného ohně. Model není určen malým dětem, mohlo by dojít k požití drobných dílů.

INSTRUCTION SIGNS

* INSTR. SYMBOLS

* INSTRUKTION

* SINNBILDEN

* SYMBOLES

* 記号の説明

OPTIONAL
VOLBABEND
OHNOUTSAND
BROUSITOPEN HOLE
VYVRTAT OTVORSYMETRICAL ASSEMBLY
SYMETRICKÁ MONTÁŽREMOVE
ODŘÍZNOUTREVERSE SIDE
OTOČITAPPLY EDUARD MASK
AND PAINT
POUŽIT EDUARD MASK
NABARVIT

PARTS



DÍLY



TEILE



PIÈCES



部品

PLASTIC PARTS

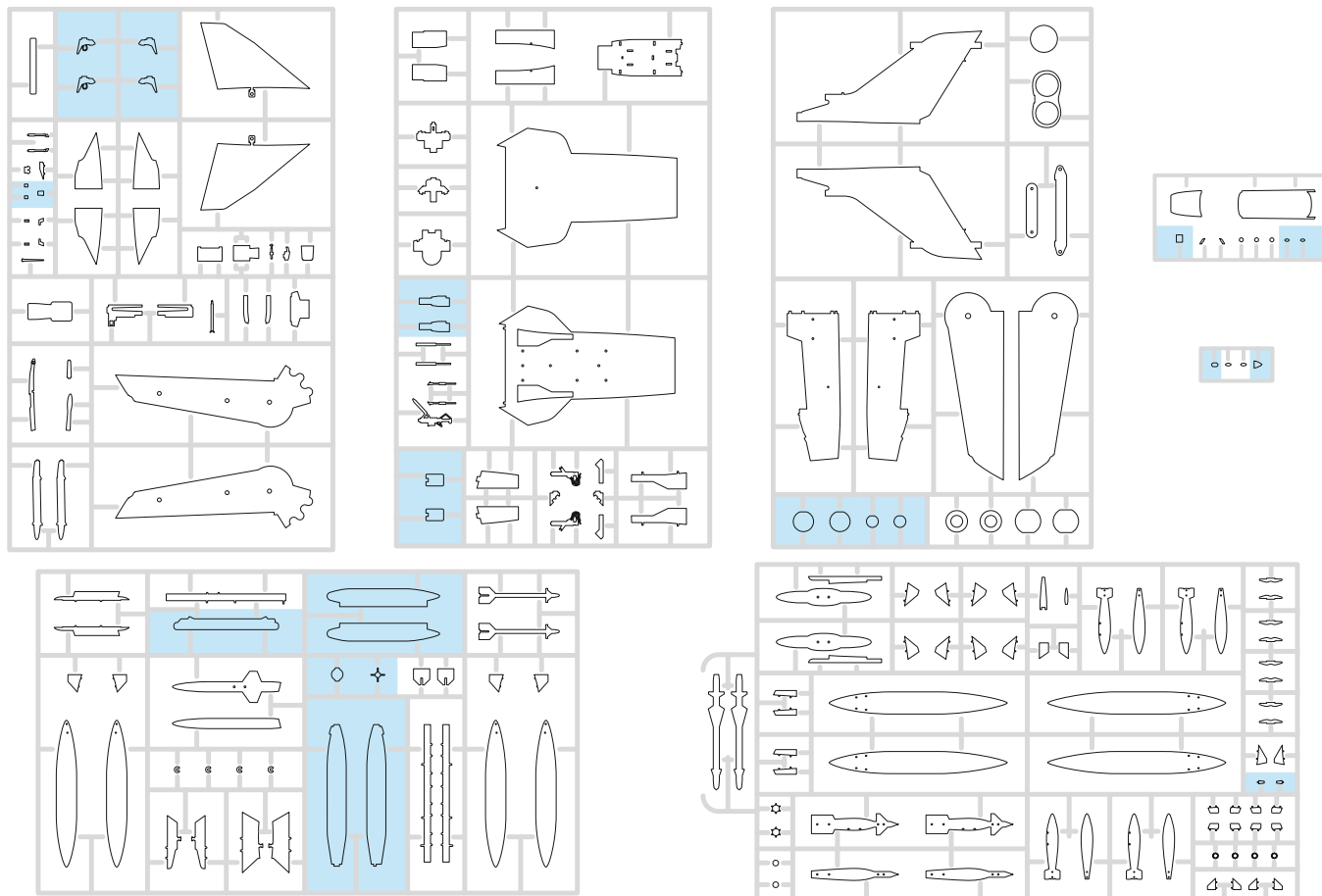

RP - RESIN PARTS

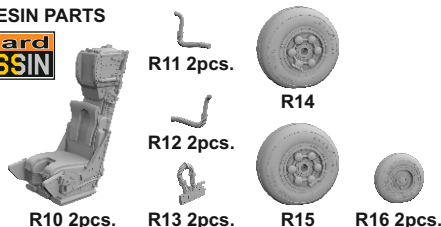

PE - PHOTO ETCHED DETAIL PARTS

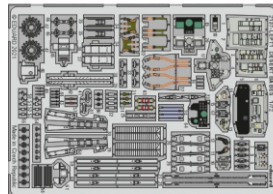
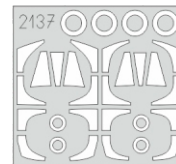
eduard
MASK

-Parts not for use. -Teile werden nicht verwendet. -Pièces à ne pas utiliser. -Tyto díly nepoužívejte při stavbě. - 使用しない部品

COLOURS



BARVY



FARBEN



PEINTURE



色

GSI Creos (GUNZE)		MISSION MODELS	
AQUEOUS	Mr.COLOR	PAINTS	
H3	C3	MMP-003	RED
H4	C4	MMP-007	YELLOW
H7	C7	MMP-002	BROWN
H11	C62	MMP-001	FLAT WHITE
H12	C33	MMP-047	FLAT BLACK
H44	C51	MMP-091	FLESH
H52	C12	MMP-091	OLIVE DRAB
H77	C137	MMP-040	TIRE BLACK
H90	C47		CLEAR RED
H94	C138		CLEAR GREEN
H306	C306	MMP-118	MEDIUM GRAY
H310	C310	MMP-060	BROWN
H317	C317	MMP-064	GRAY

GSI Creos (GUNZE)		MISSION MODELS	
AQUEOUS	Mr.COLOR	PAINTS	
H318	C318	MMP-070	RADOME
H331	C331		DARK SEAGRAY
H334	C334	MMP-102	BARLEY GRAY
H338	C338	MMP-116	LIGHT GRAY
H421	C121	MMP-052	BROWN VIOLET
	C124		DARK GREEN
Mr.METAL COLOR		METALLICS	
MC213		MMM-006	STEEL
MC214		MMM-001	DARK IRON
MC218		MMM-003	ALUMINIUM
Mr.COLOR SUPER METALLIC		METALLICS	
SM201		MMC-001	SUPER FINE SILVER

A **eduard** **BRASSIN** 2 pcs.

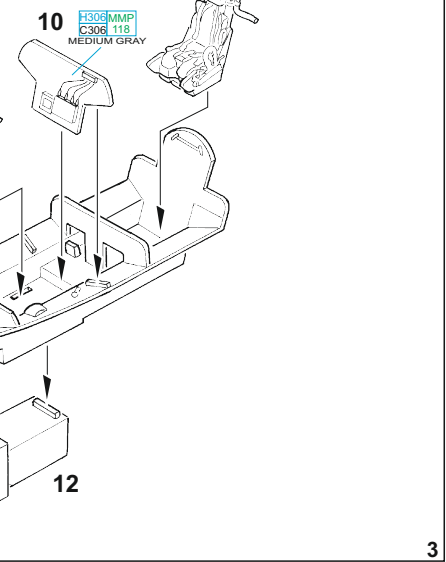
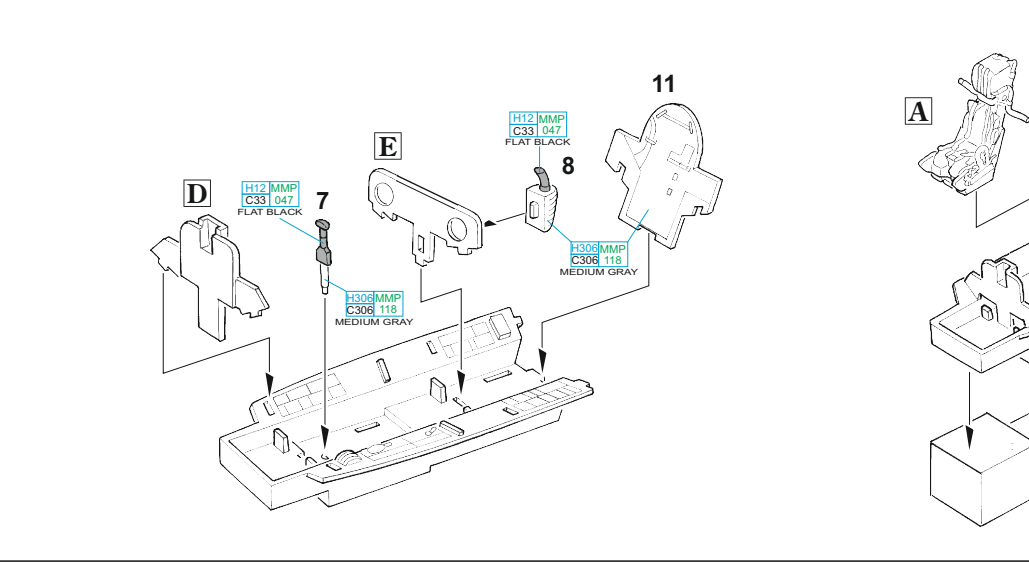
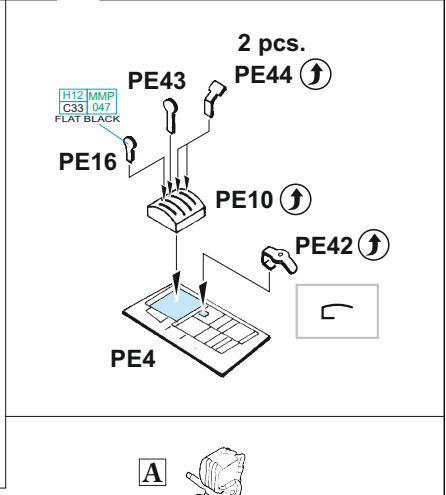
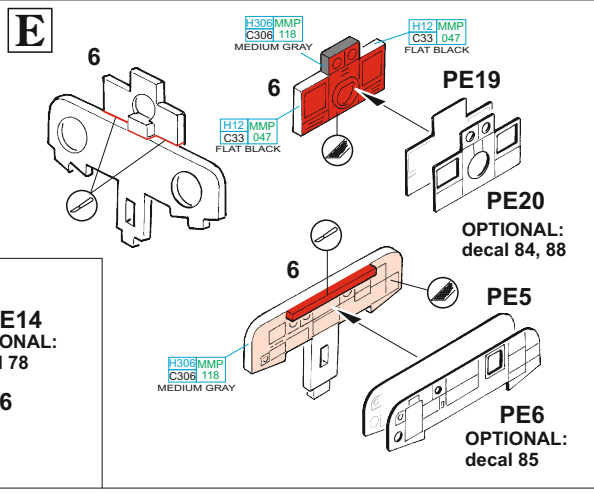
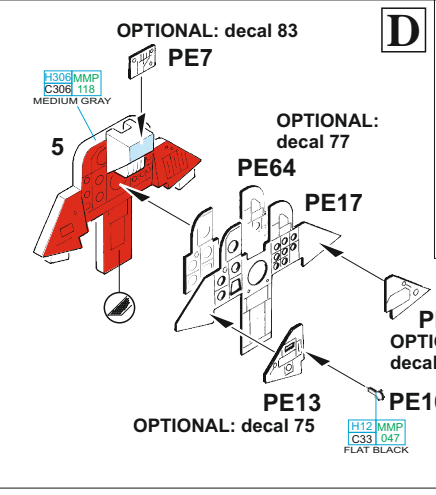
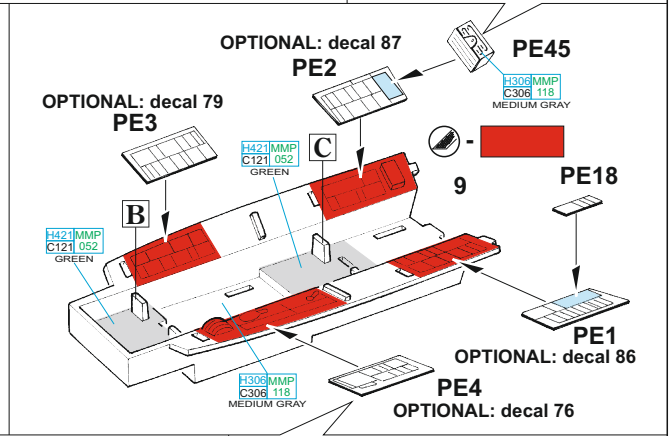
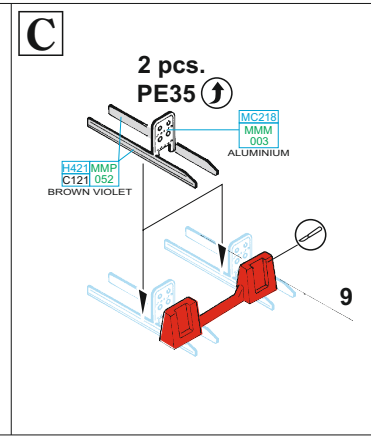
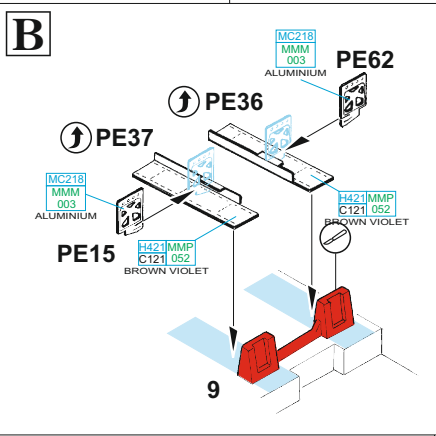
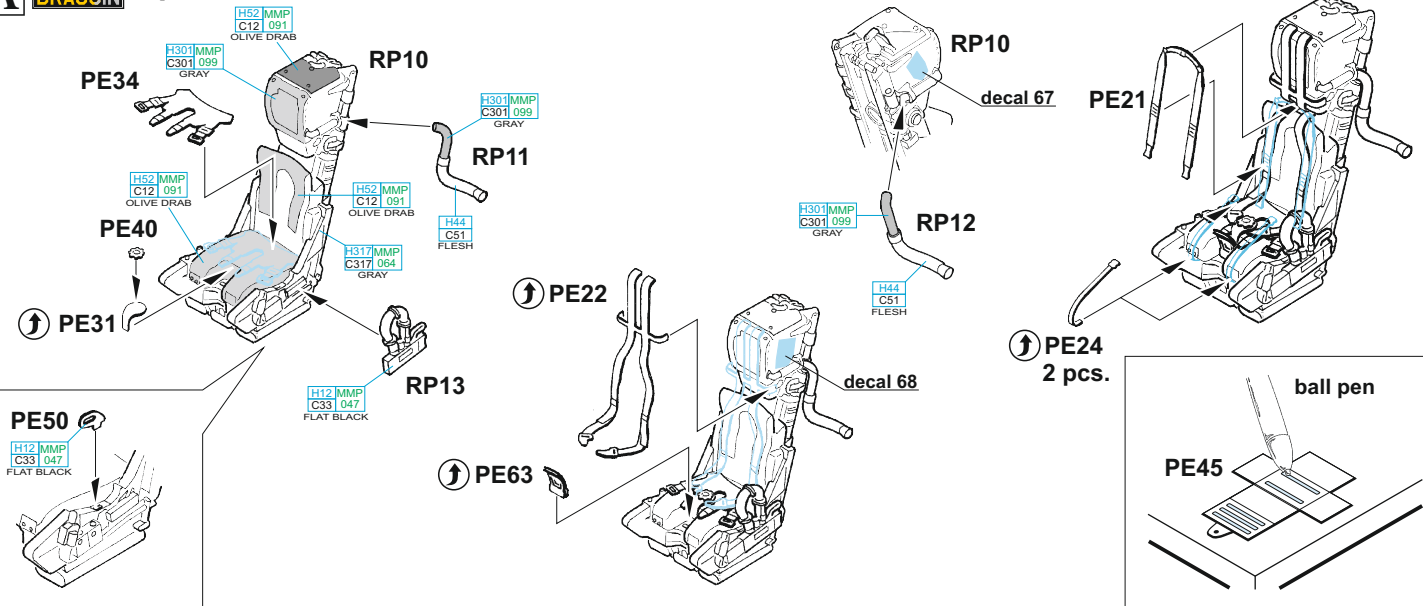

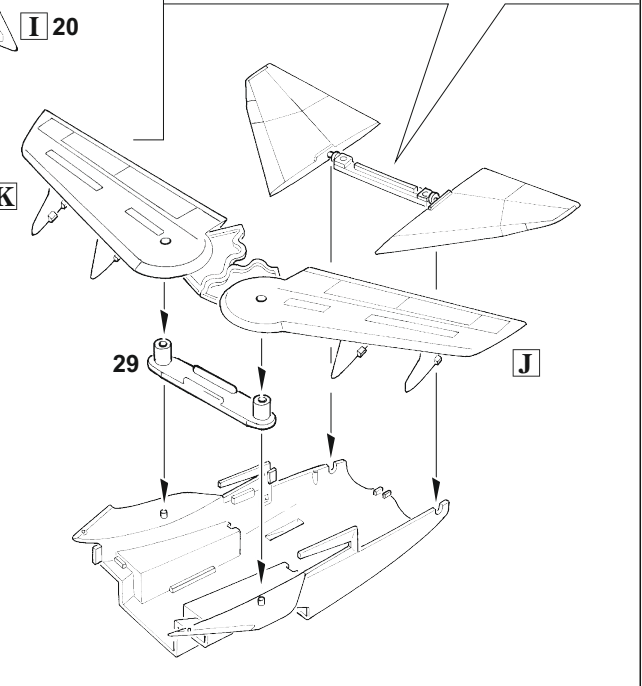
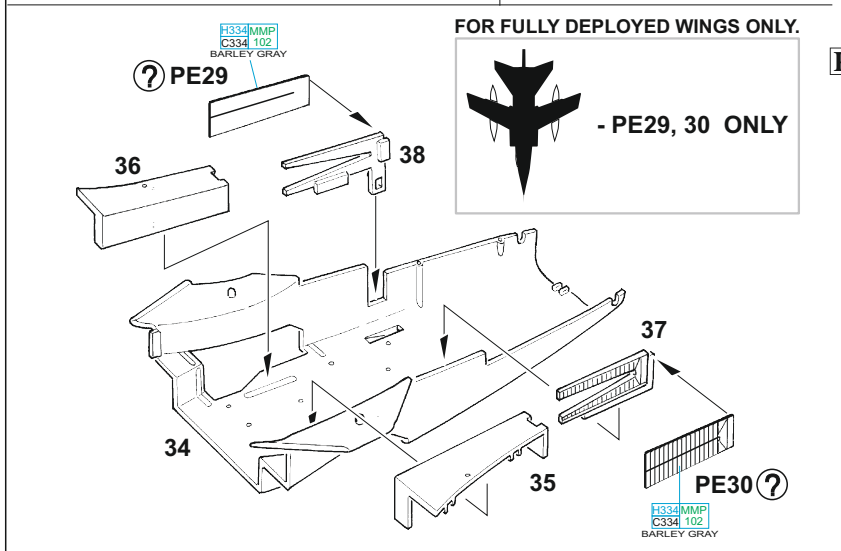
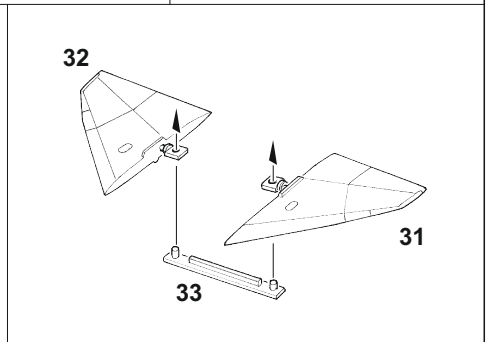
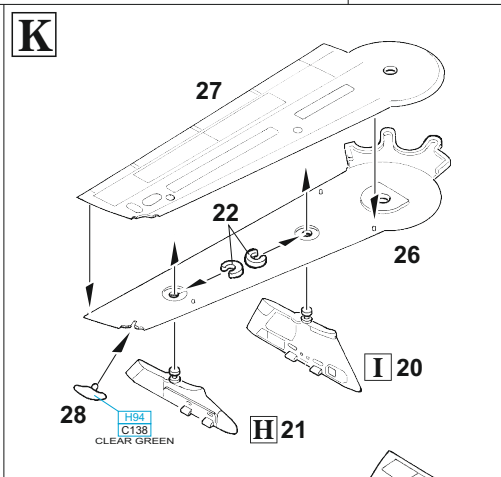
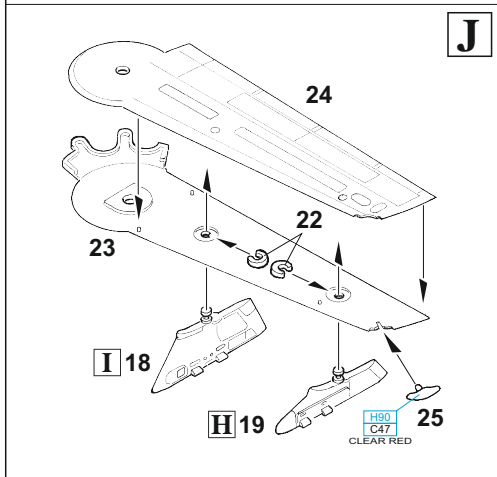
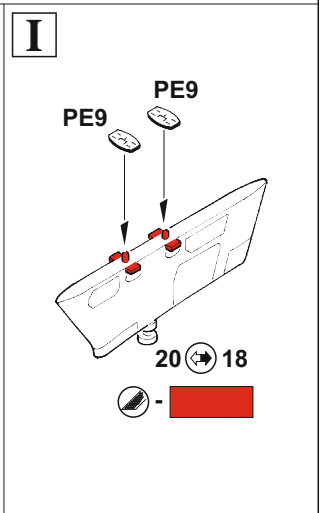
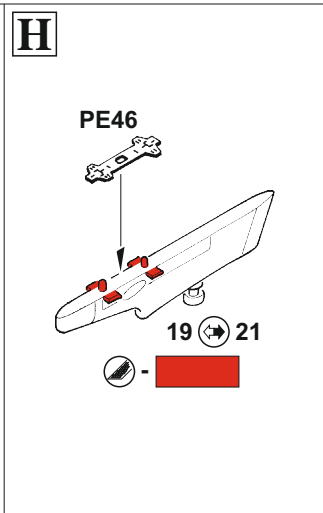
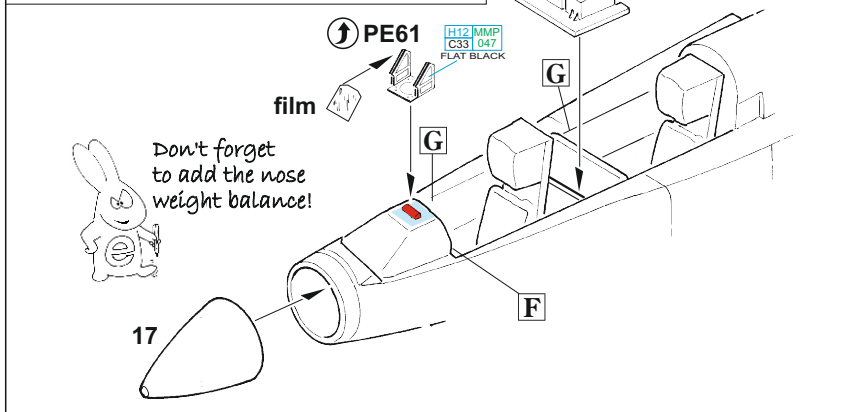
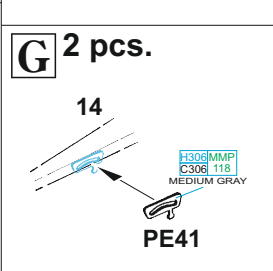
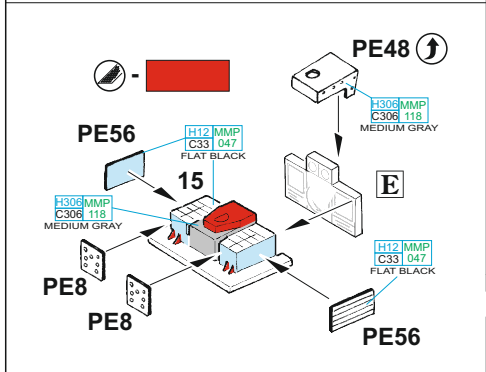
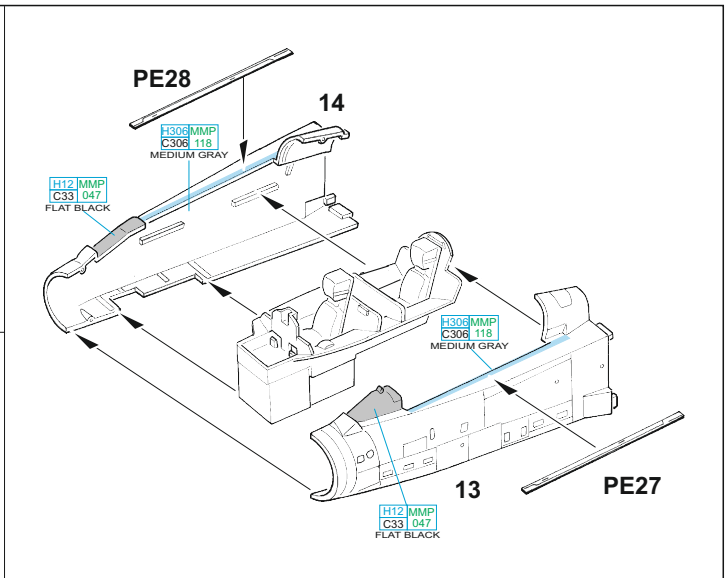
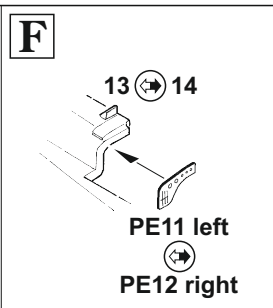
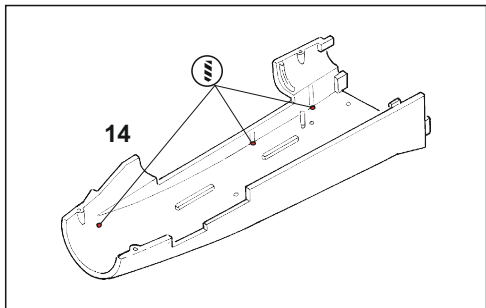

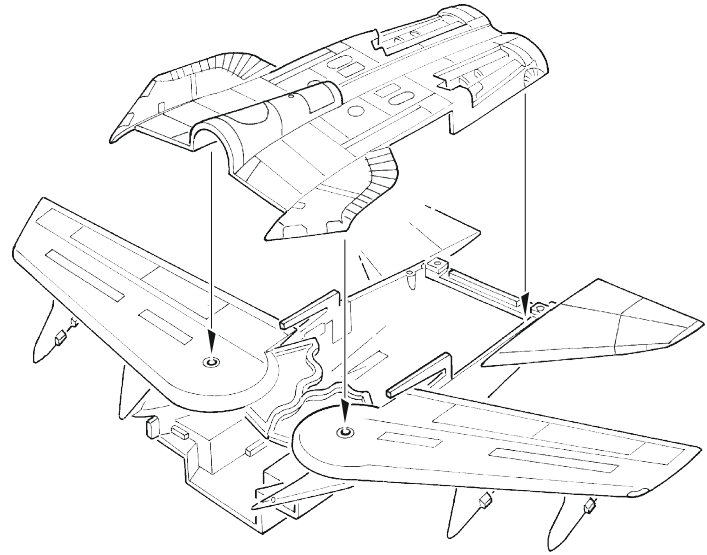
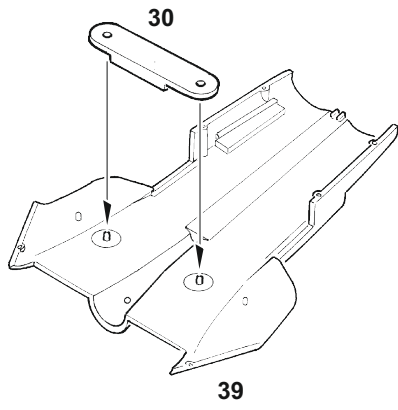

L

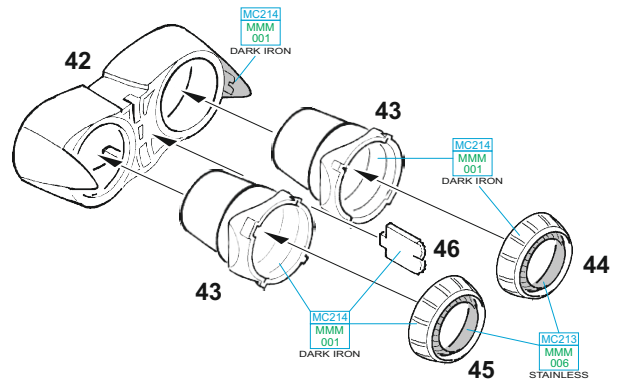
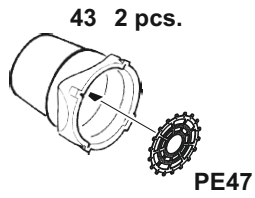
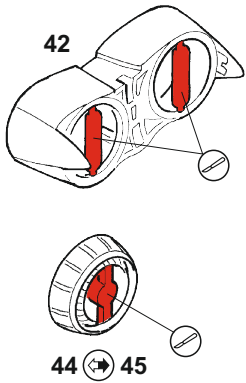

M

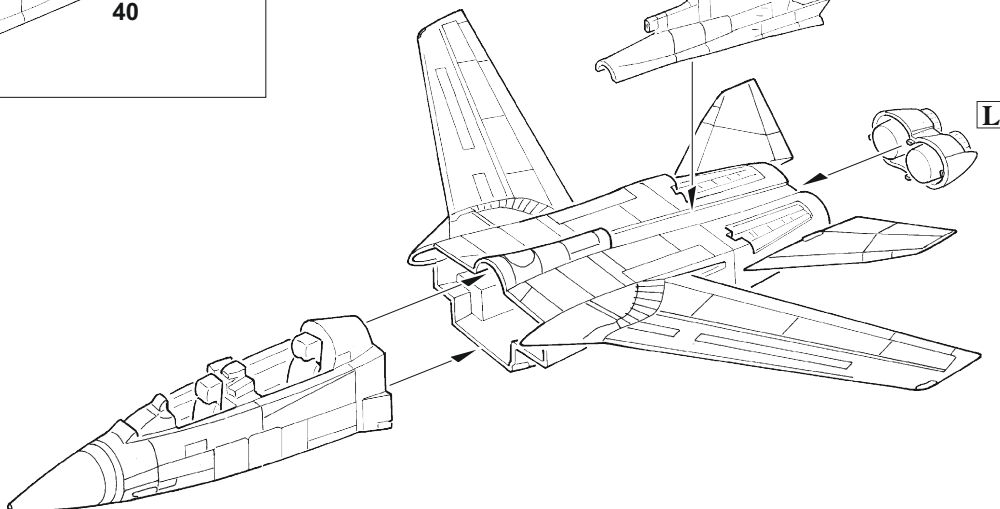
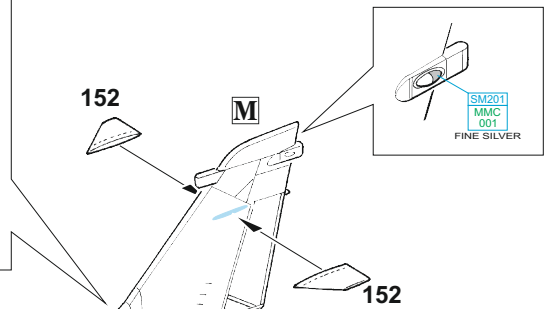
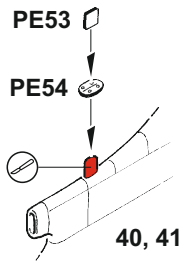
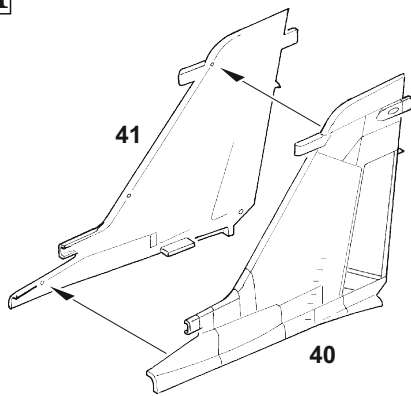

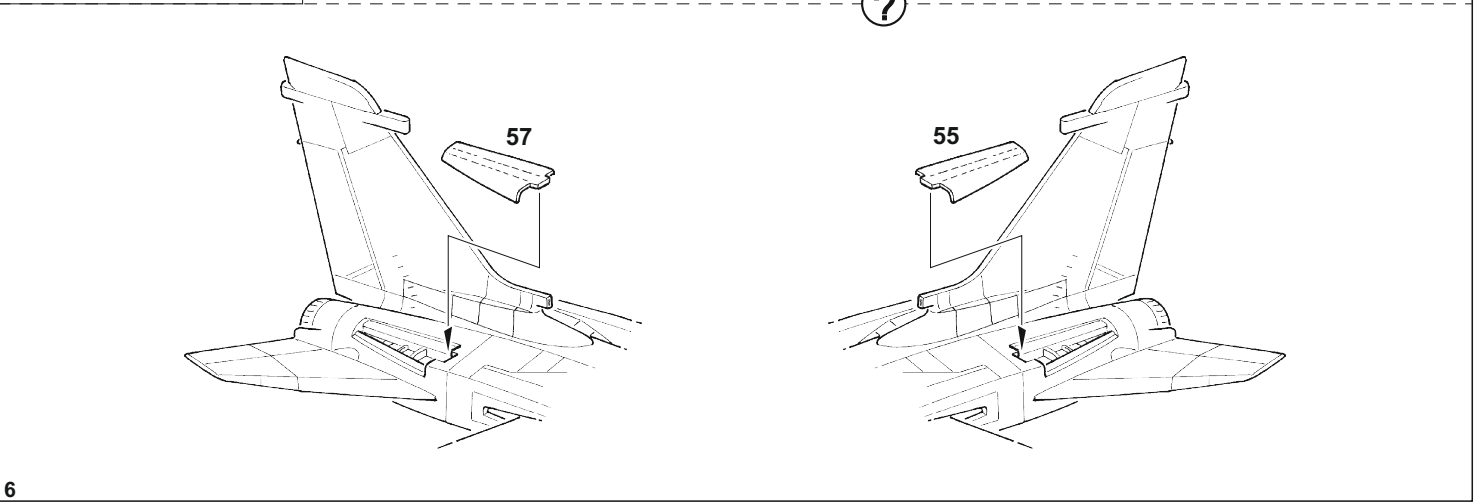
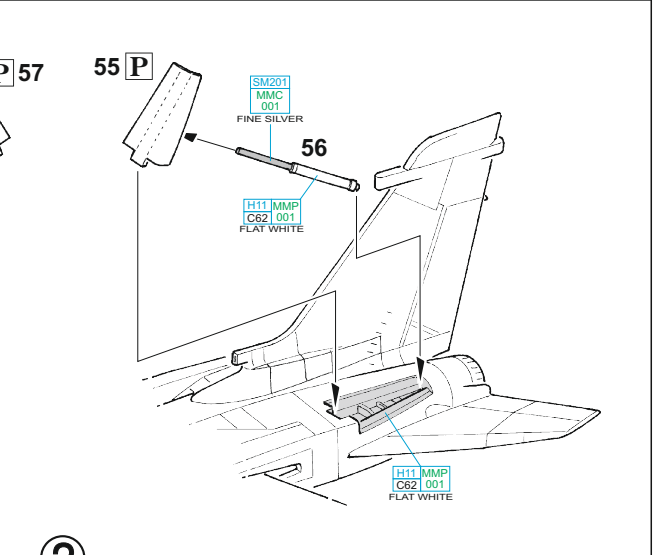
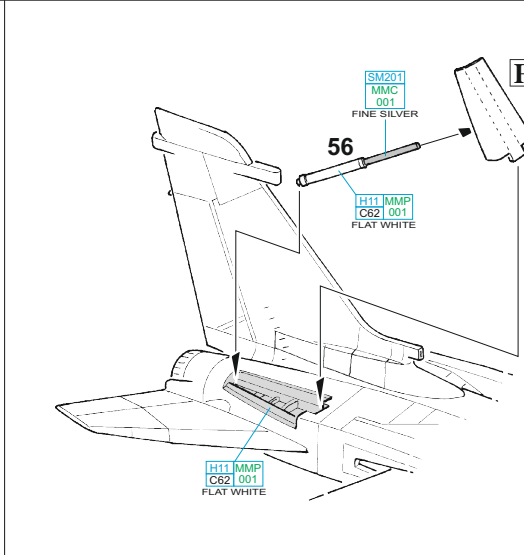
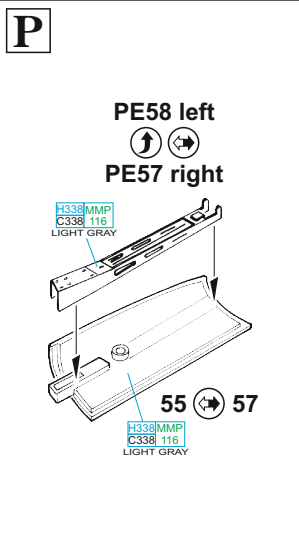
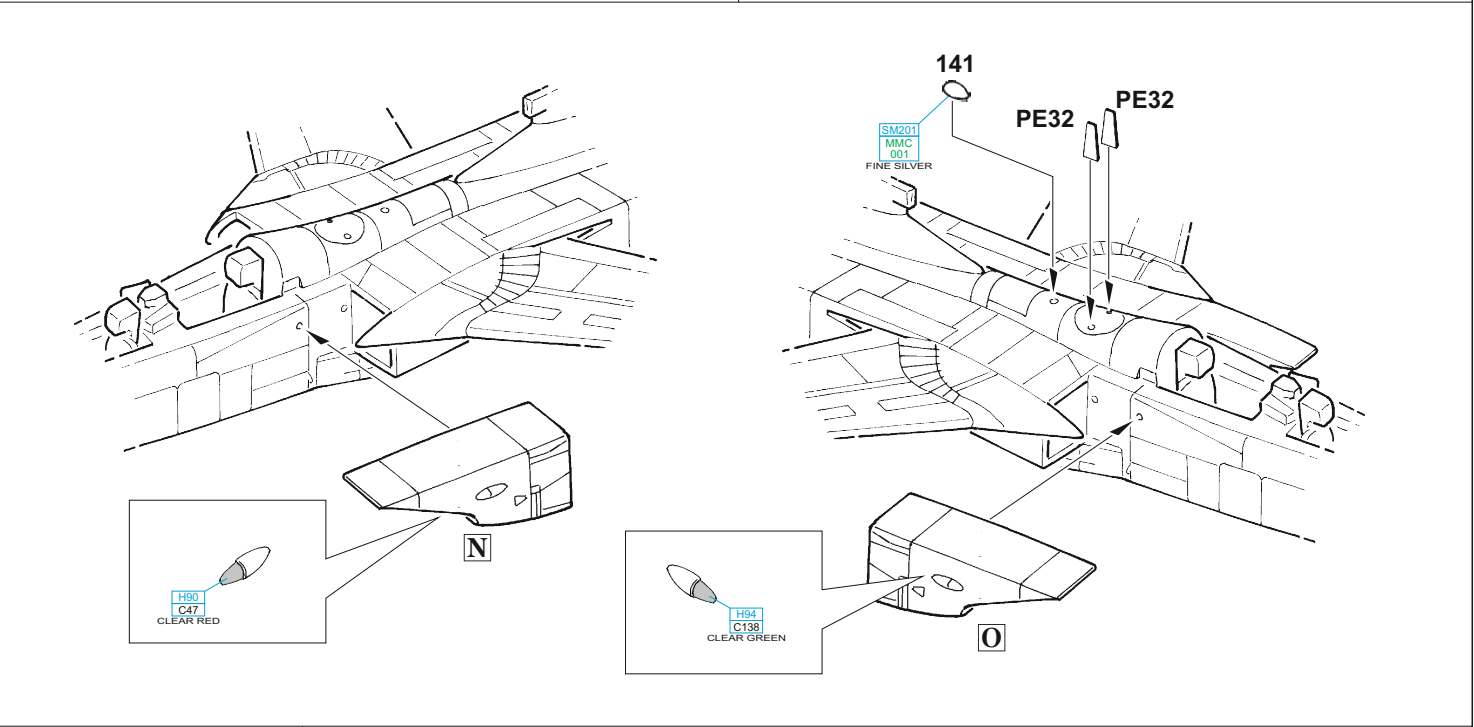
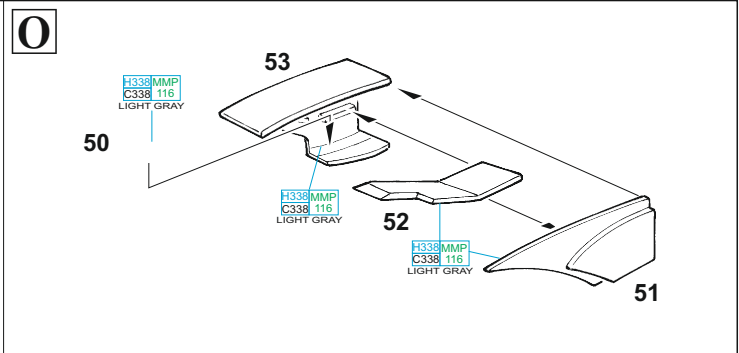
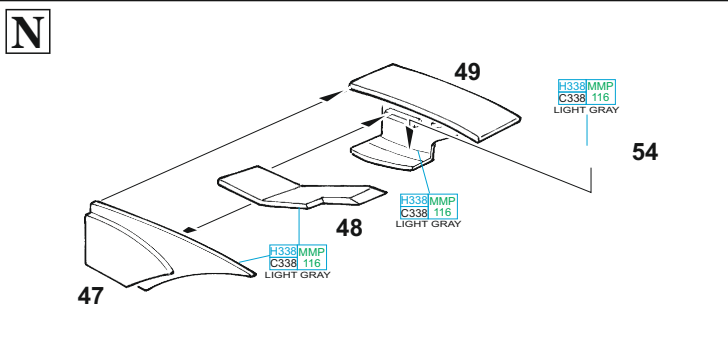

eduard
BRASSIN

RP16

H77 MMP
C137 040
TIRE BLACK

1. SM201
MMC
001
FINE SILVER

2. H11 MMP
C62 001
FLAT WHITE

PE23

H11 MMP
C62 001
FLAT WHITE

58

H11 MMP
C62 001
FLAT WHITE

SM201
MMC
001
FINE SILVER

H11 MMP
C62 001
FLAT WHITE

H77 MMP
C137 040
TIRE BLACK

RP16

H11 MMP
C62 001
FLAT WHITE

eduard
BRASSIN

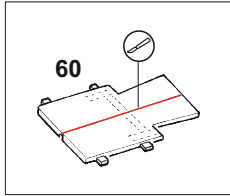
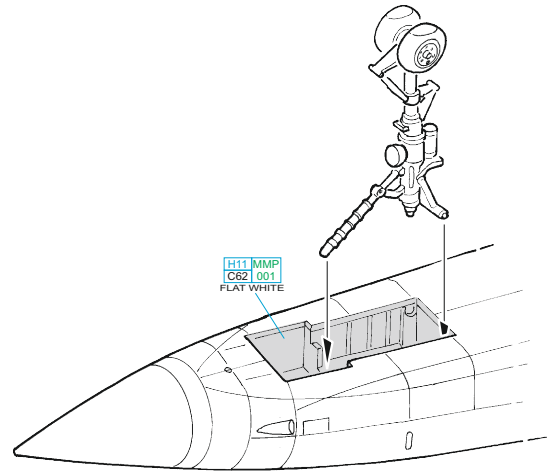

60

60

H11 MMP
C62 001
FLAT WHITE

61

H11 MMP
C62 001
FLAT WHITE

H11 MMP
C62 001
FLAT WHITE

60

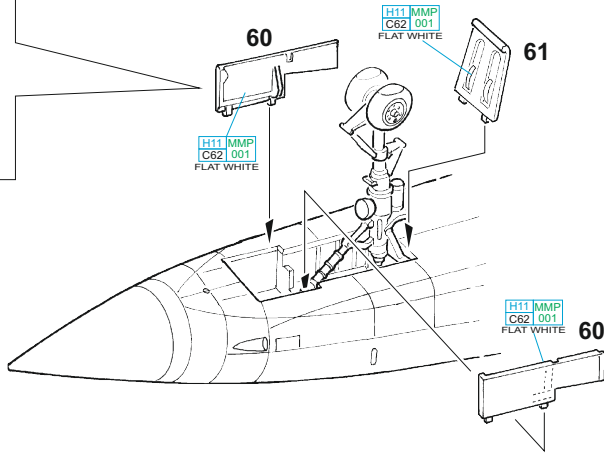

RP15

eduard
BRASSIN

H77 MMP
C137 040
TIRE BLACK

SM201
MMC
001
FINE SILVER

H11 MMP
C62 001
FLAT WHITE

71

H11 MMP
C62 001
FLAT WHITE

72

H11 MMP
C62 001
FLAT WHITE

73

H11 MMP
C62 001
FLAT WHITE

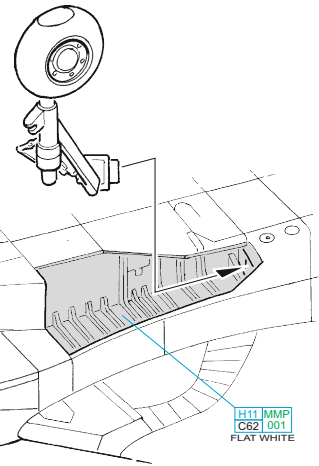

H11 MMP
C62 001
FLAT WHITE

SM201
MMC
001
FINE SILVER

66

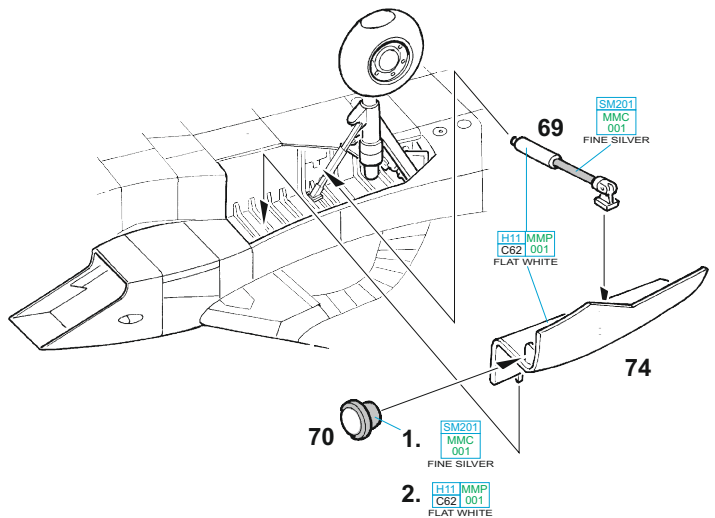
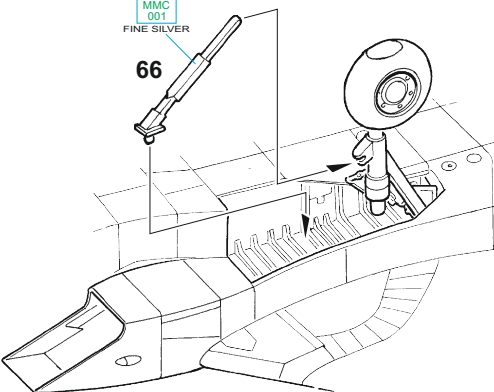

SM201
MMC
001
FINE SILVER

69

H11 MMP
C62 001
FLAT WHITE

74

70

1. SM201
MMC
001
FINE SILVER

2. H11 MMP
C62 001
FLAT WHITE

RP14
eduard
BRASS

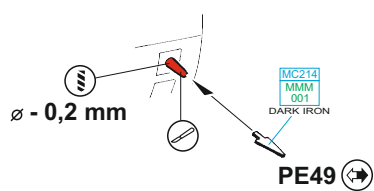
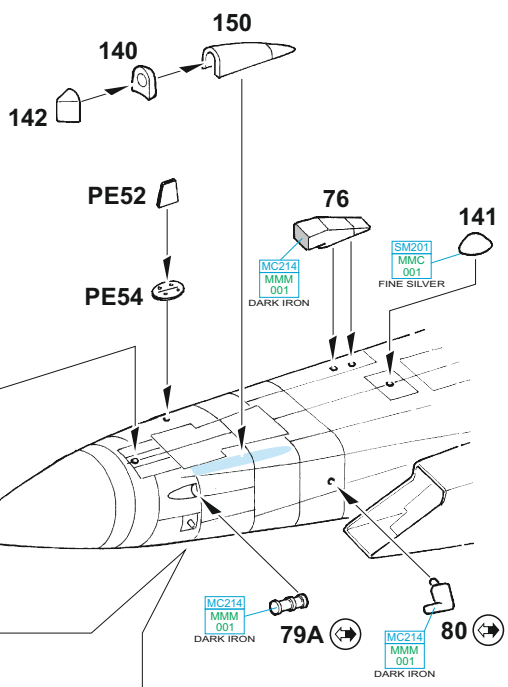
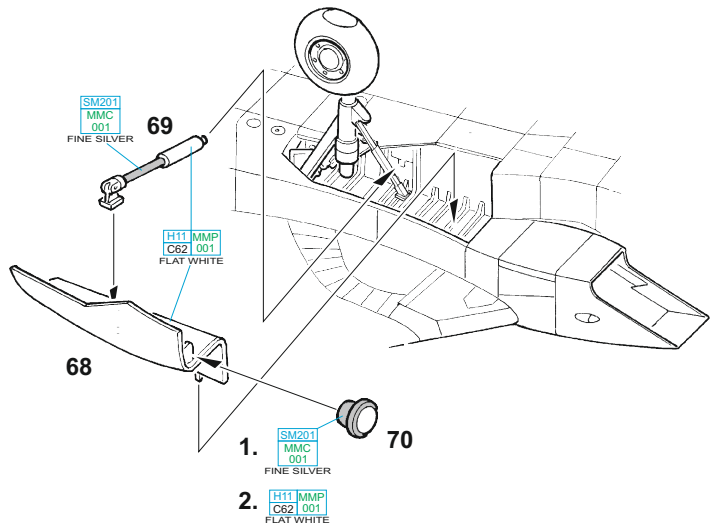
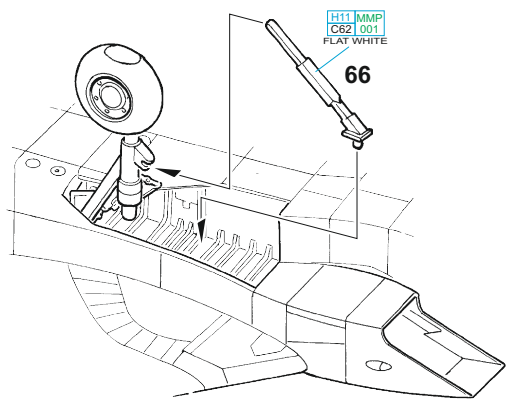
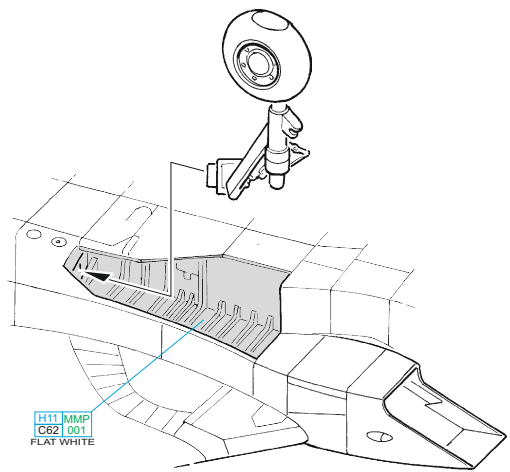
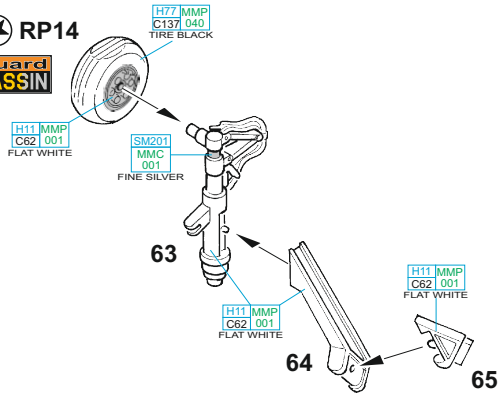

Q

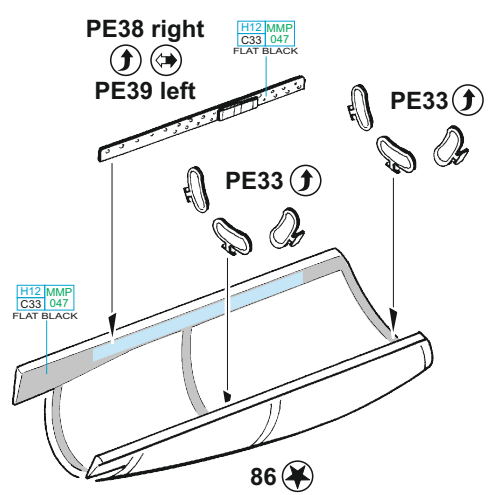
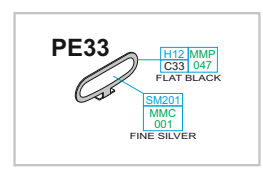

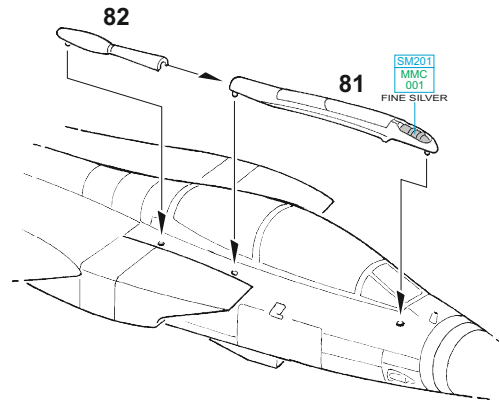
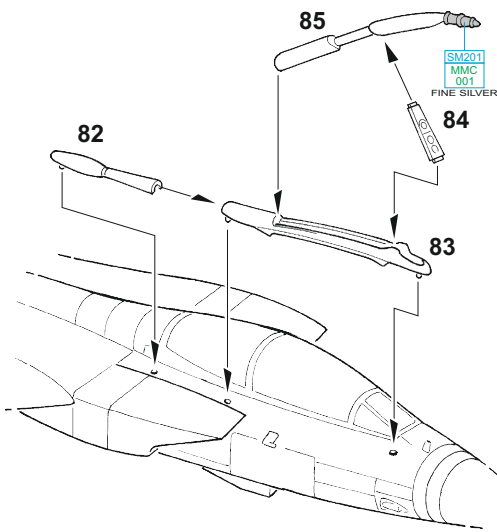
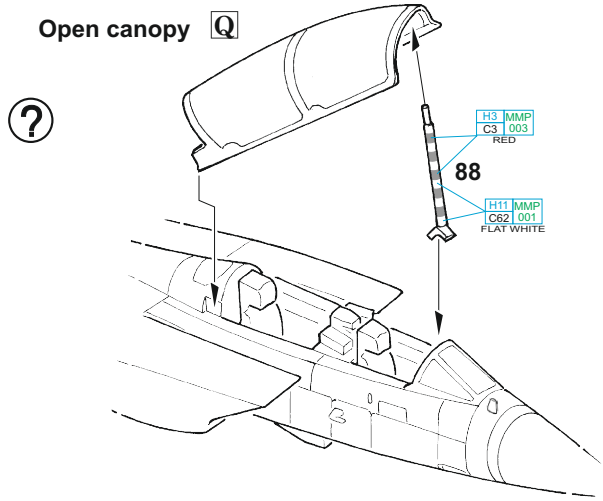
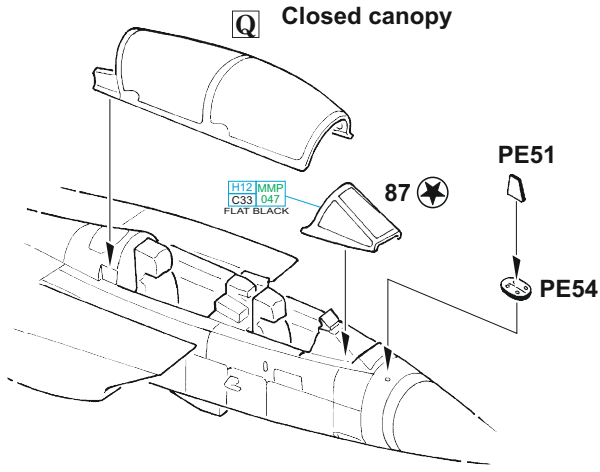

R 2 pcs.

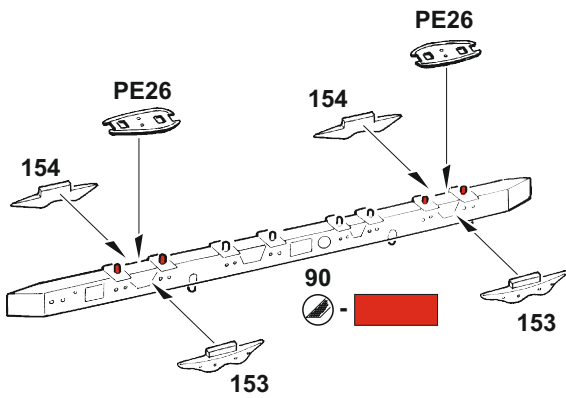

S

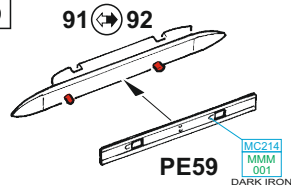

T

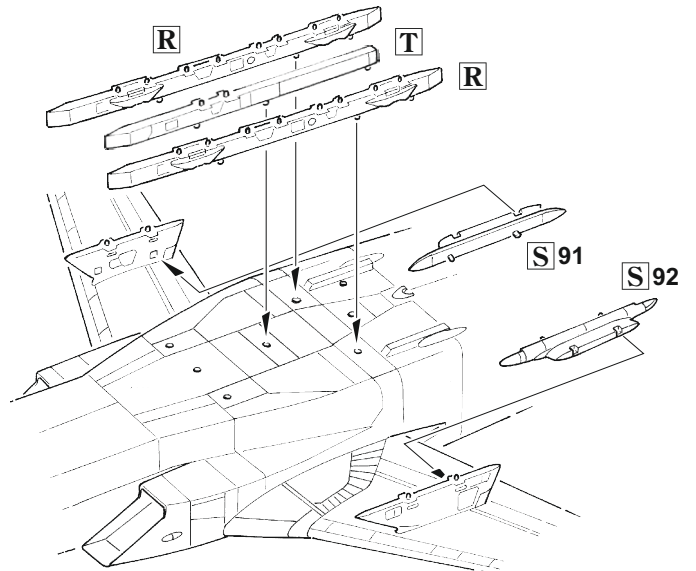
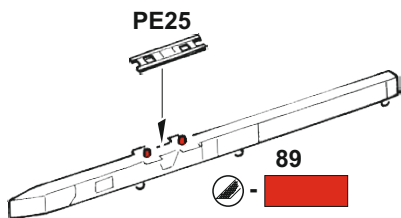

1 1500 Ltr. tank
2 pcs.

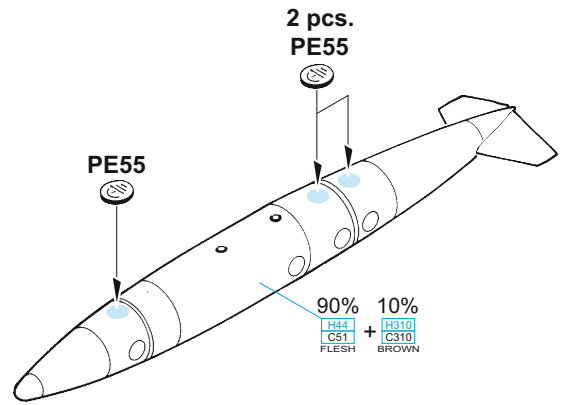
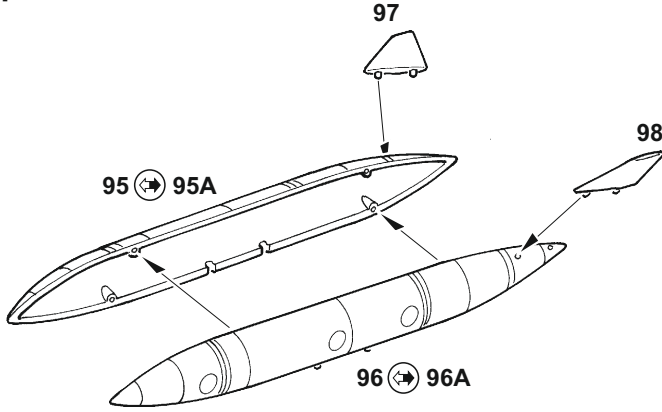

2 2250 Ltr. Hindenburger tank
2 pcs.

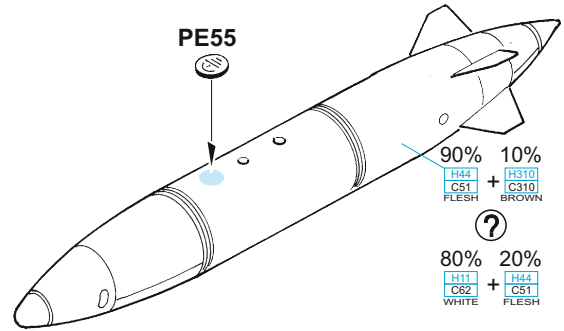
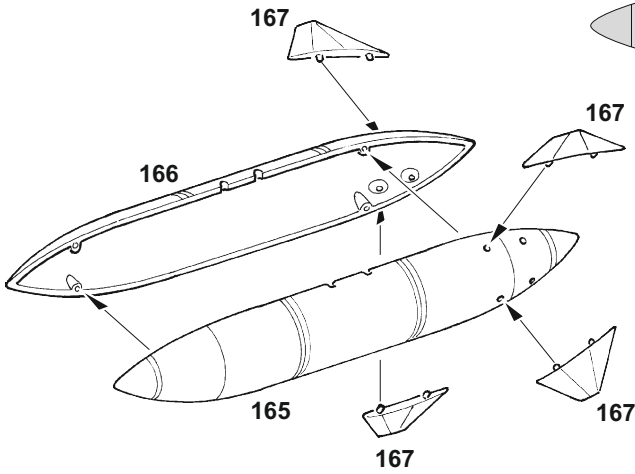

3 CPU-123 Laser guided bomb
2 pcs.

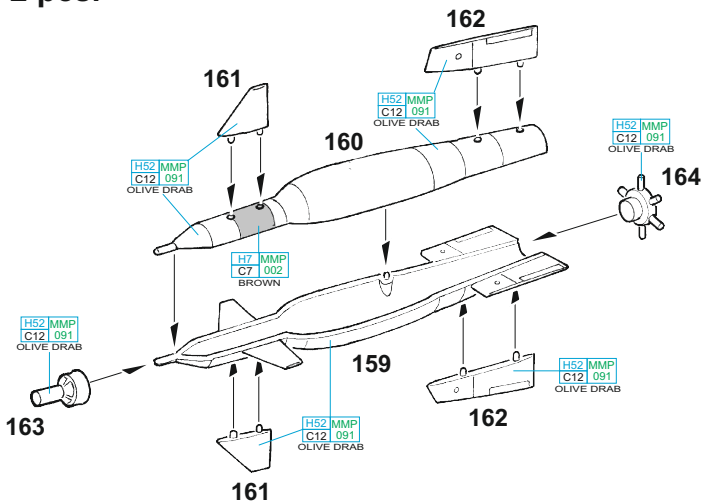

4 Sky Shadow pod

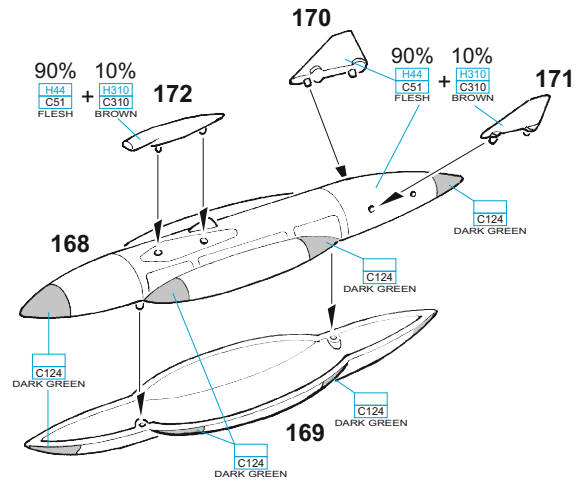

5 AIM-9
2 pcs.

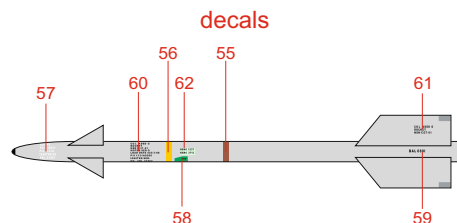
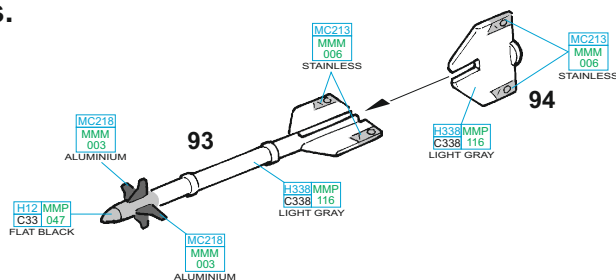

6 BOZ 101

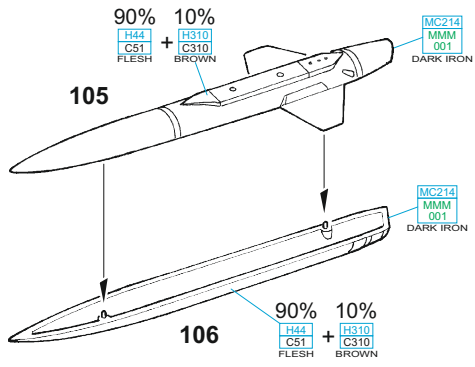

**7 1000 lb bomb
4 pcs.**

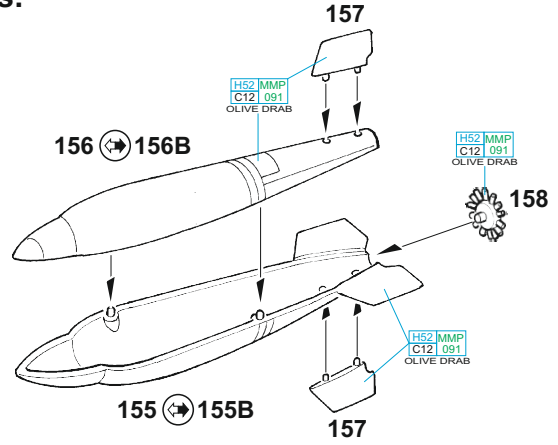

**8 ALARM
2 pcs.**

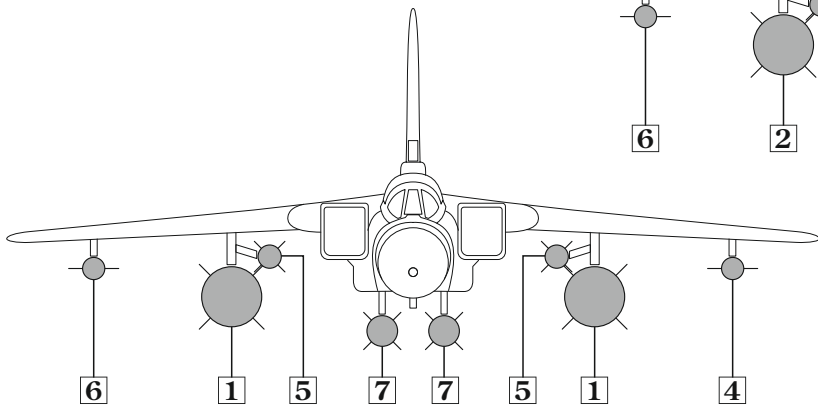
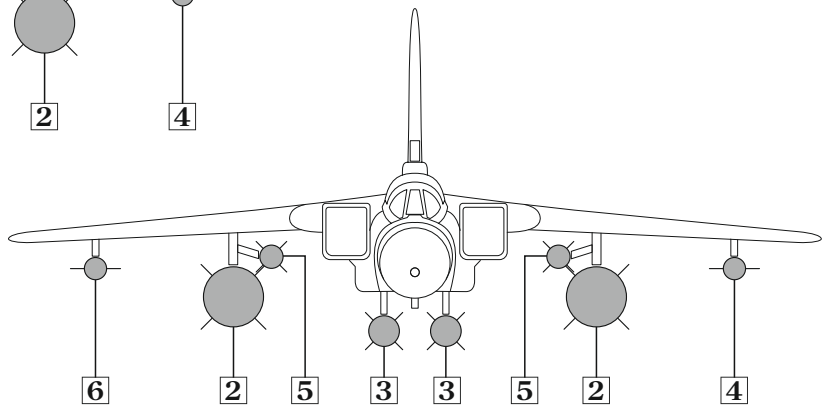
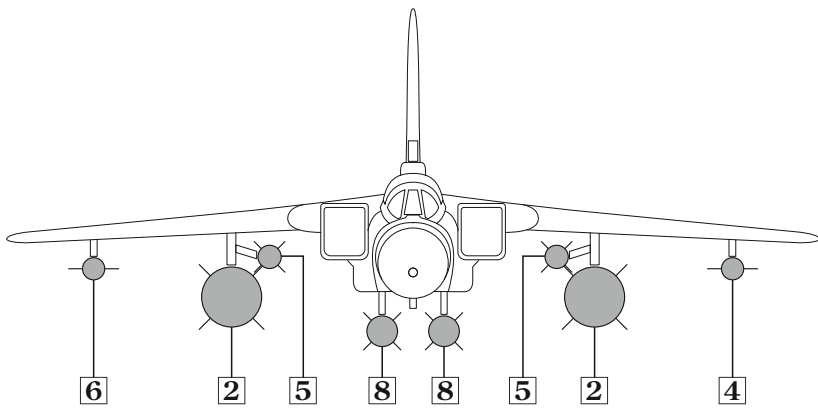
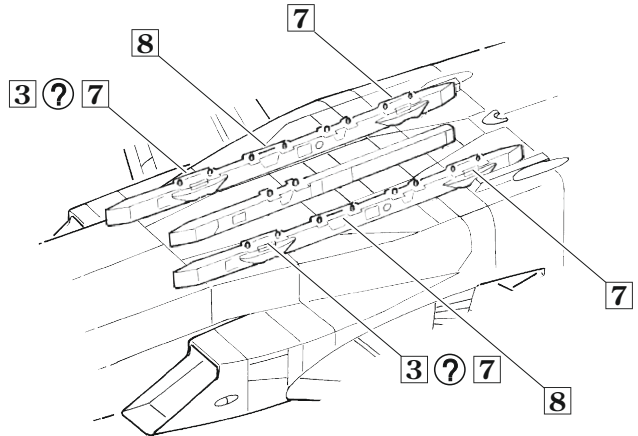
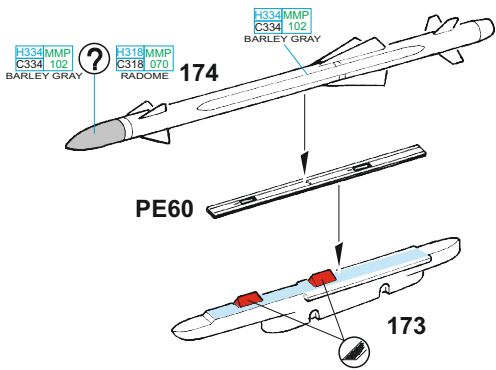

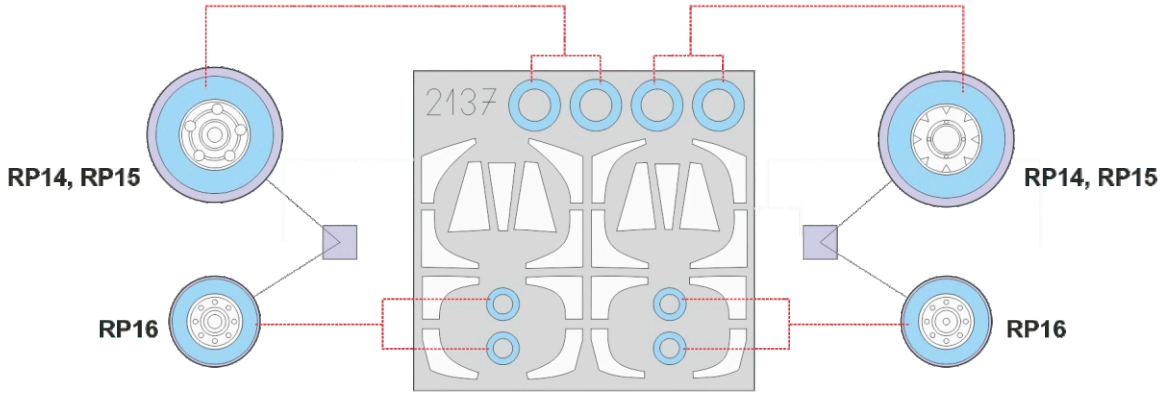

LIQUID MASK ■



1.)

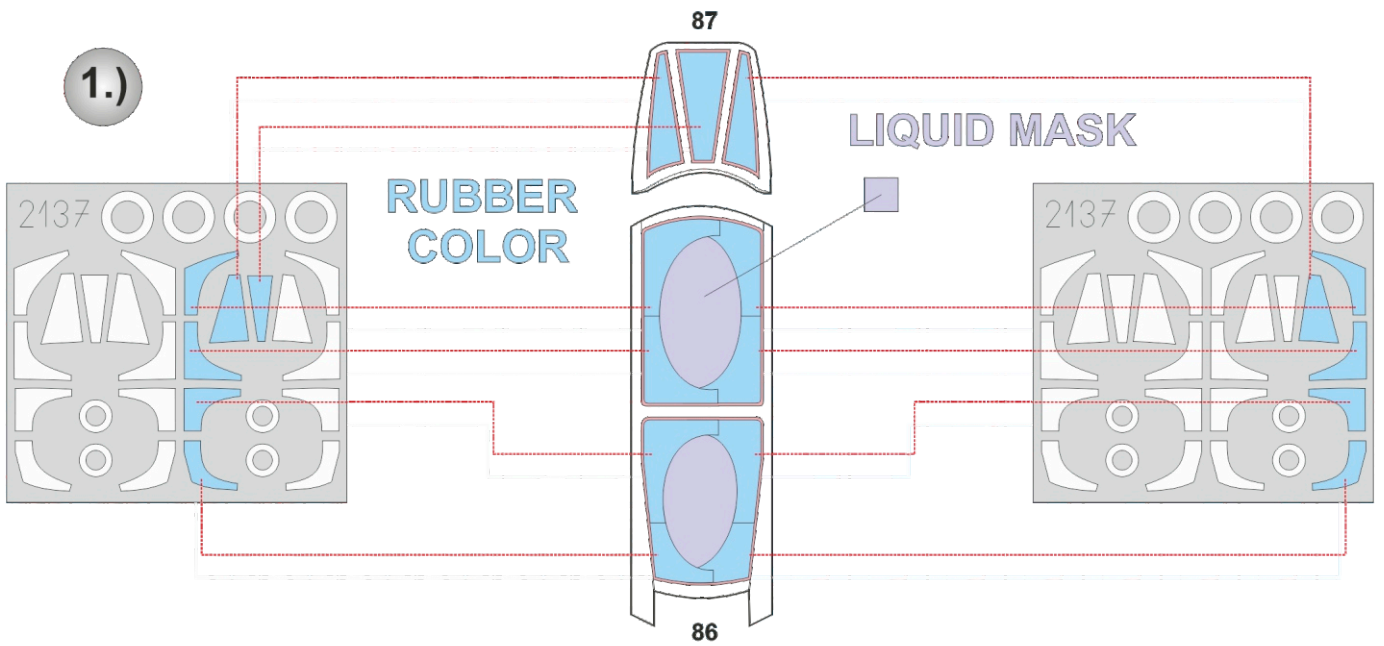

2.)

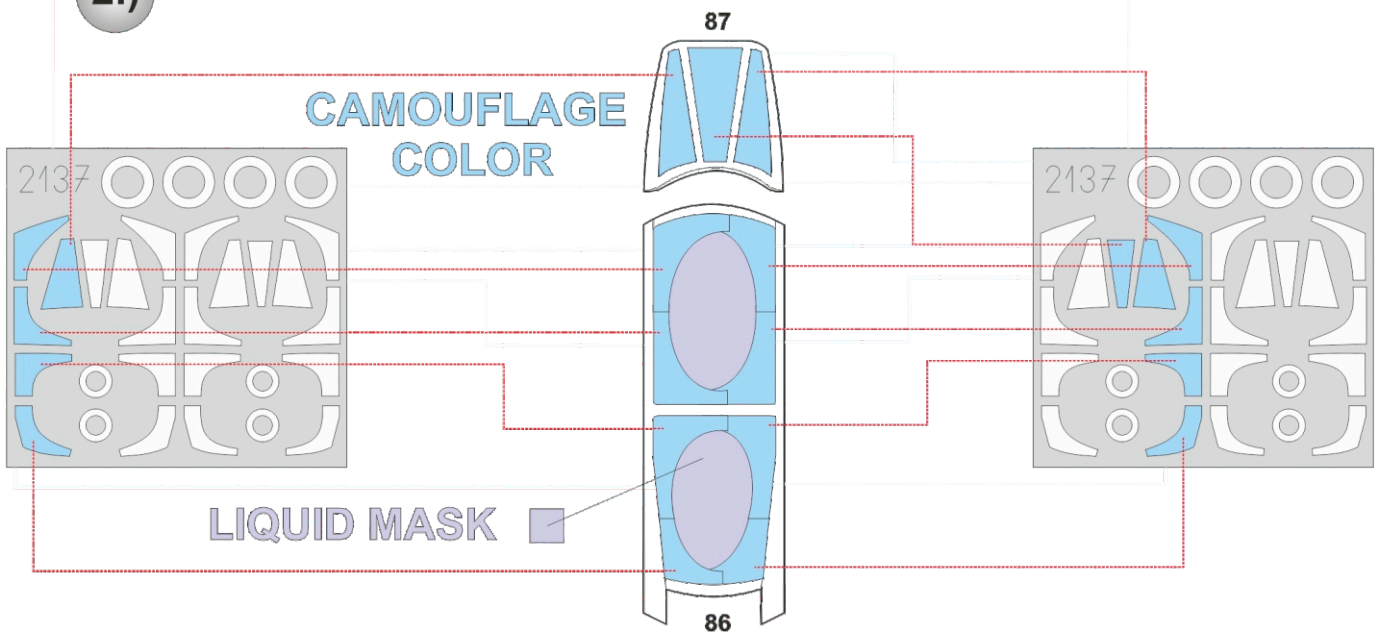

A ZA465, Foxy Killer, No. 16 Squadron, Tabuk AB, Saudi Arabia, 1991

Aircraft from No. 16 Squadron, based at RAF Laarbruch, a British airbase in Ruhrland-Vestfalia territory, deployed in late September 1990 to Muharraq airbase, Bahrain. Shortly after, ZA465 moved with others of the GR.1 fleet to the Tabuk airbase and in the course of Operation Granby ZA465/FK completed the highest number of missions achieved by any of the Tornado GR.1s during the operation, including a symbol for destroying a MiG-29. This aircraft carried a pale blue and pink sharksmouth.

ČESKOU VERZI TEXTU NALEZNETE NA
www.eduard.com
 POD KATALOGOVÝM ČÍSLEM 2137

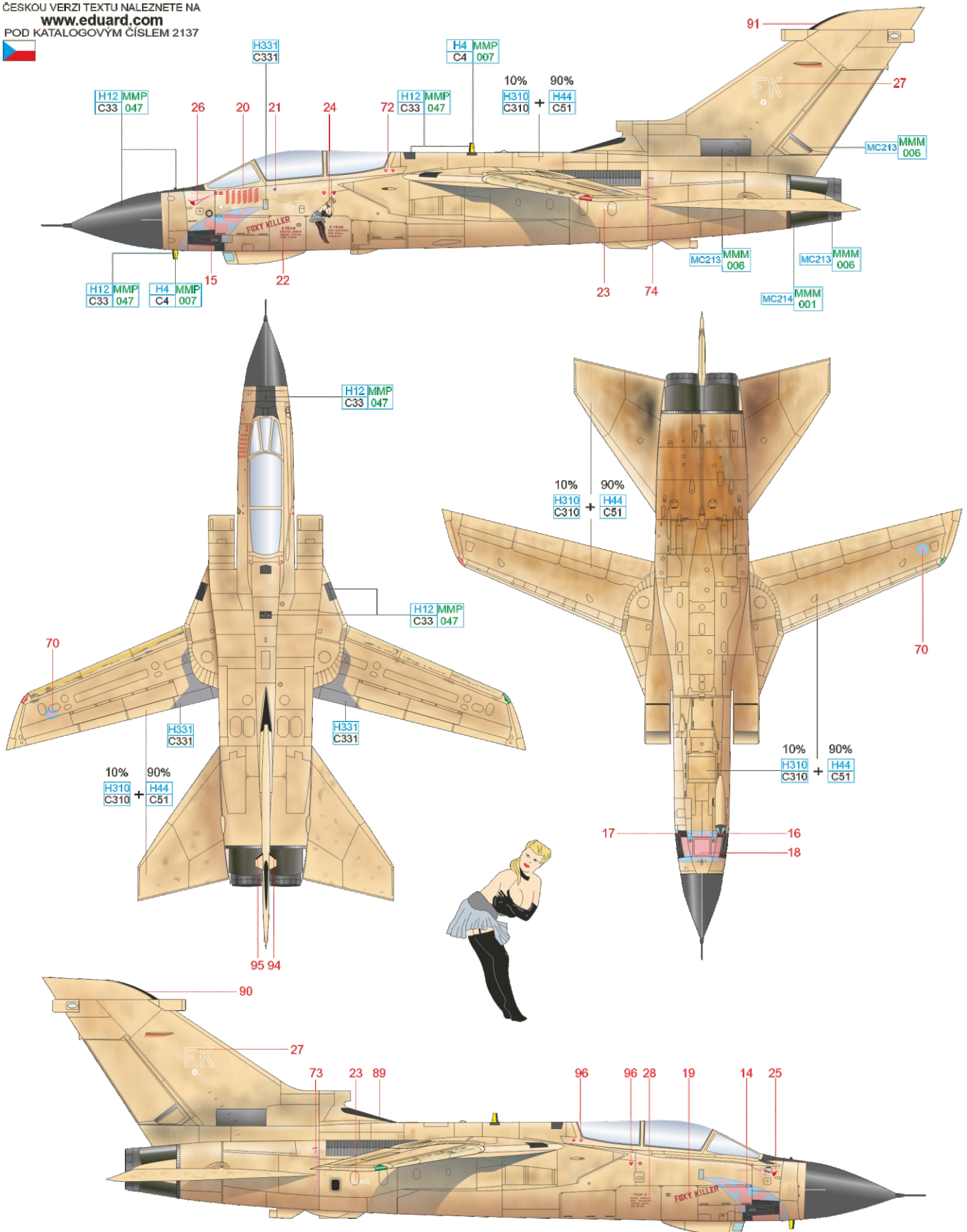

YELLOW	H4 MMP C4 007	BROWN	H310 C310	FLESH	H44 C51
BLACK	H12 MMP C33 047	DARK SEA GRAY	H331 C331	STEEL	MC213 MMM 006
				DARK IRON	MC214 MMM 001

B ZD809, Awesome Annie, No. 617 Squadron, Muharraq AB, Bahrain, 1991

Part of the forces operating out of the Muharraq airbase in Bahrain was also No. 15 Squadron detachment, supported by No. 9, 27 and 617 Squadrons. Several aircraft flying sorties out of this base had the inscription 'Hello Kuwait G' Bye Iraq' painted under the canopy. ZD809/BA was complemented with pin-up girl 'Awesome Annie' holding a bomb. By the end of the conflict, 33 mission markings were painted on the left side of the nose as well.

ČESKOU VERZI TEXTU NALEZNETE NA
www.eduard.com
 POD KATALOGOVÝM ČÍSLEM 2137

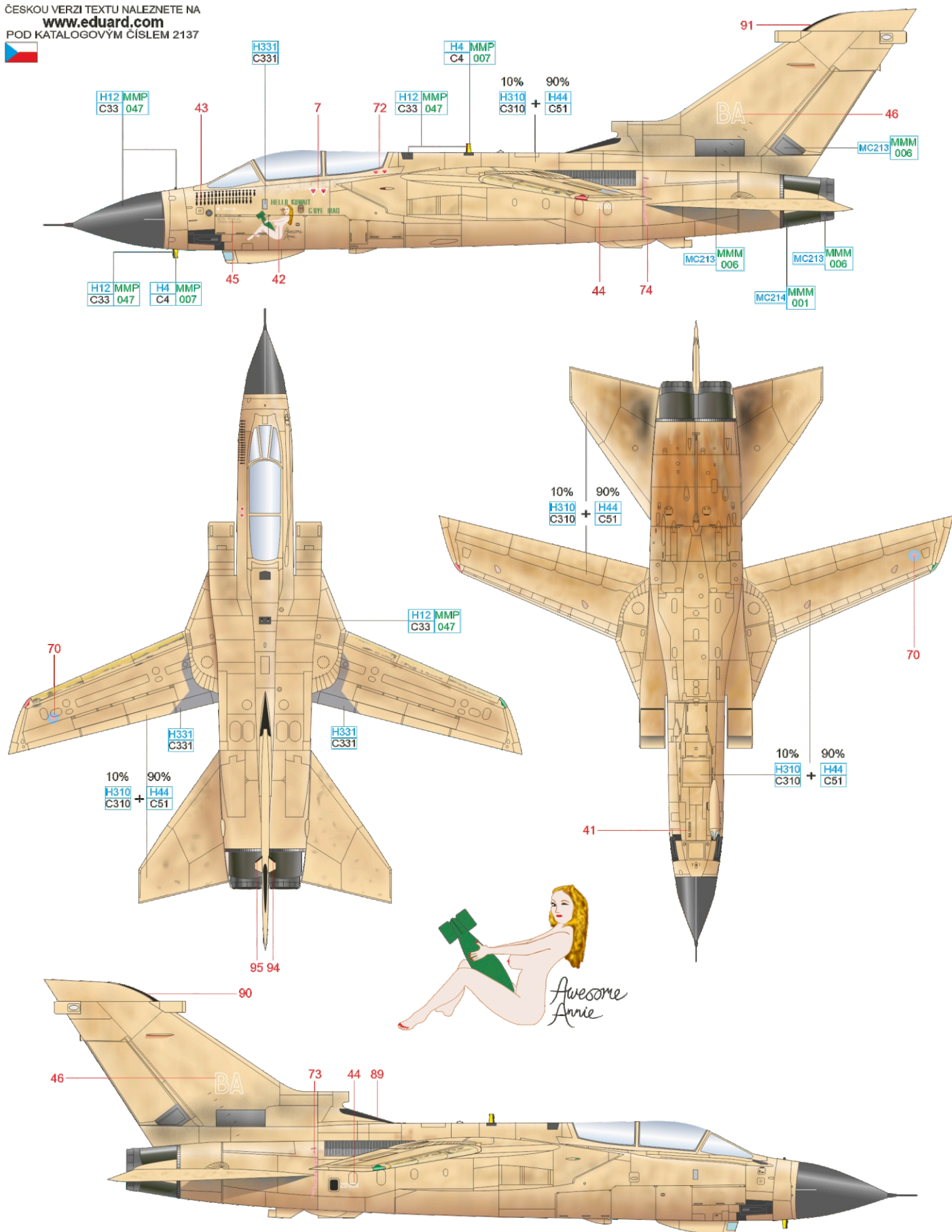

YELLOW	H4 MMP C4 007	BROWN	H310 C310	FLESH	H44 C51
BLACK	H12 MMP C33 047	DARK SEA GRAY	H331 C331	STEEL	MC213 MMM 006
				DARK IRON	MC214 MMM 001

C ZD739, Armoured Charmer, No. 9 Squadron, Tabuk AB, Saudi Arabia, 1991

ZD739/AC was one of the aircraft modified to carry the Thermal Imaging Airborne Laser Designator pod (TIALD). This device marked, or 'spiked' the targets selected to guide laser guided bombs carried by other Tornado's. There were 36 TIALD mission markings under the windshield as well as a pretty girl called 'Armoured Charmer' leaning against the bomb nose art.

ČESKOU VERZI TEXTU NALEZNETE NA
www.eduard.com
 POD KATALOGOVÝM ČÍSLEM 2137

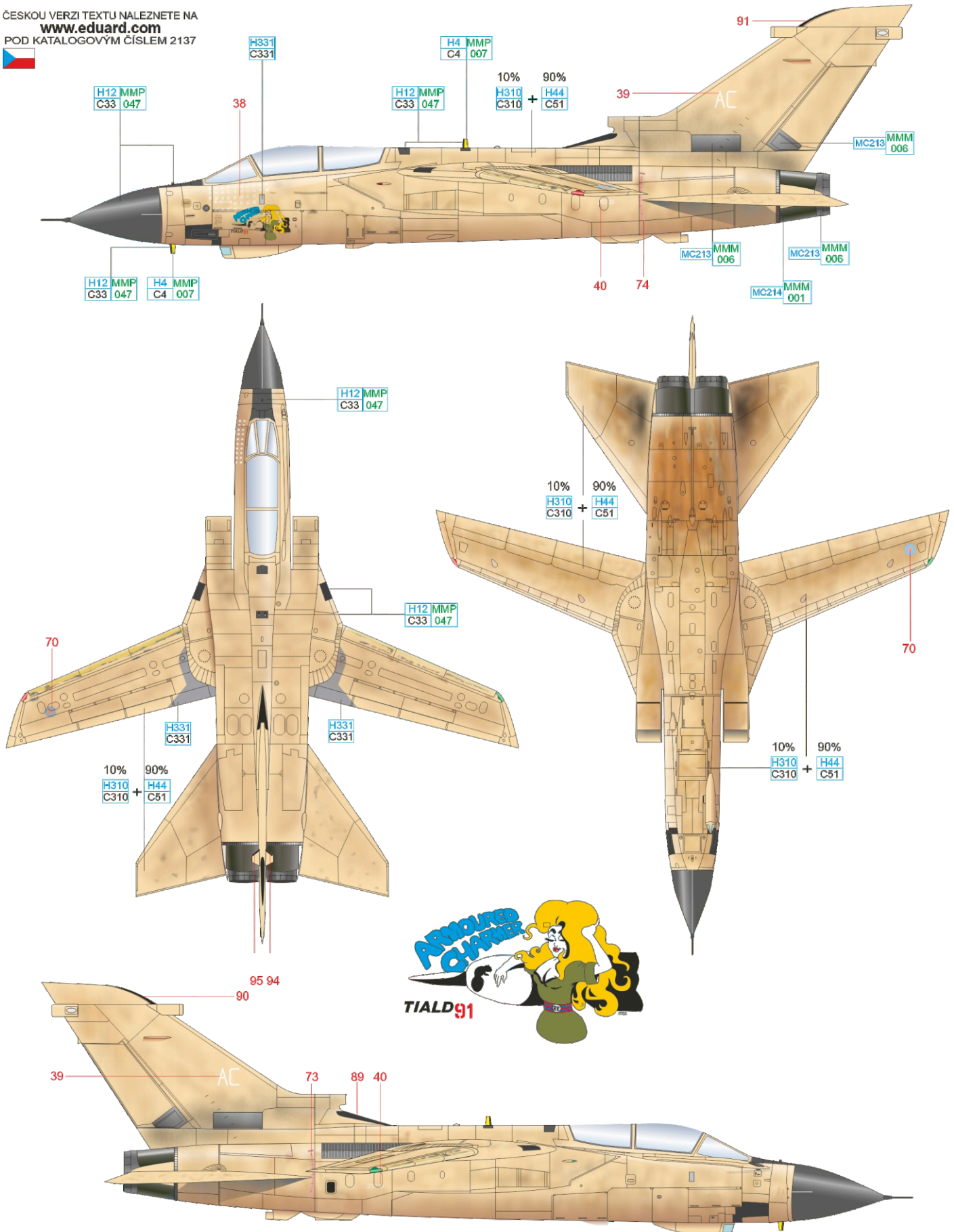

YELLOW	H4 MMP C4 007	BROWN	H310 C310	FLESH	H44 C51
BLACK	H12 MMP C33 047	DARK SEA GRAY	H331 C331	STEEL	MC213 MMM 006
					DARK IRON MC214 MMM 001

D ZA452, Gulf Killer, No. 20 Squadron, Tabuk AB, Saudi Arabia, 1991

One of the sixty Tornado GR.1s deployed by the Royal Air Force during Operation Granby was ZA452/GK, from No. 20 Squadron, operating out of Tabuk airbase, Saudi Arabia. Before the departure to the Middle East, these Tornados were over sprayed in the Alkali temporary removable paint called Desert Pink, a mixed paint to match Desert Sand FS30279. ZA452 was named 'Gulf Killer' which originated from the No. 20 Squadron tail code letters GK, painted in white outline font. A sharkmouth and a lady sitting on a Paveway II bomb were painted on the aircraft nose. The 31 mission markings were continuously added under the windshield during the operation.

ČESKOU VERZI TEXTU NALEZNETE NA

www.eduard.com

POD KATALOGOVÝM ČÍSLEM 2137

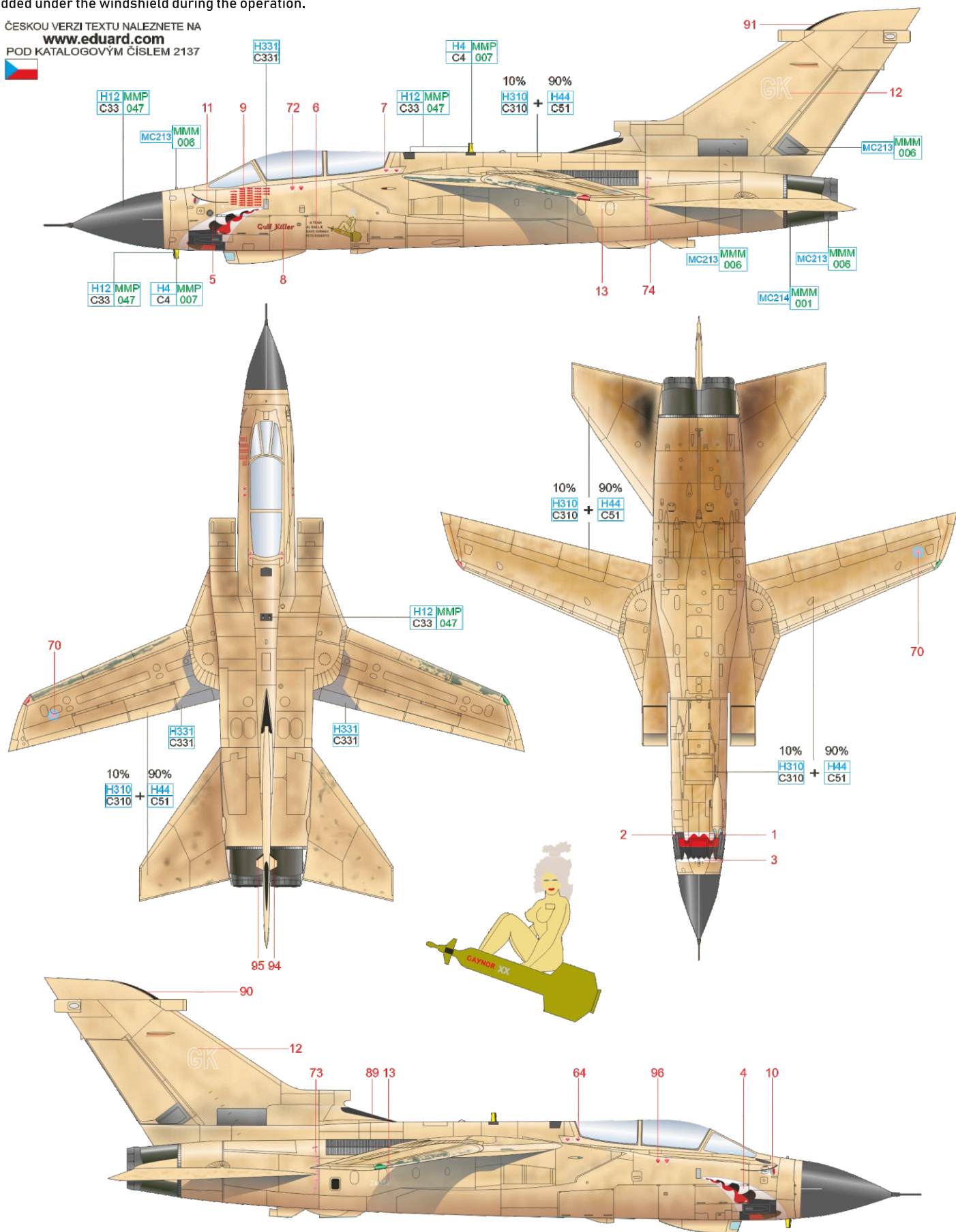

YELLOW	H4 MMP C4 007	BROWN	H310 C310	FLESH	H44 C51
BLACK	H12 MMP C33 047	DARK SEA GRAY	H331 C331	STEEL	MC213 MMM 006
				DARK IRON	MC214 MMM 001

eduard

E ZD719, Check Six, No. 9 Squadron, Dhahran AB, Saudi Arabia, 1991

ZD719/AD of No. 9 Squadron initially deployed to Tabuk airbase, but transferred to the No. 31 Squadron led detachment, which operated from Dhahran airbase in Saudi Arabia. The ground crew added a pin-up girl nose art to the well-known pilot's rule to watch your back (Check Six!) painted under the windshield. ZD719 had 5 mission markings applied.

ČESKOU VERZI TEXTU NALEZNETE NA
www.eduard.com
 POD KATALOGOVÝM ČÍSLEM 2137

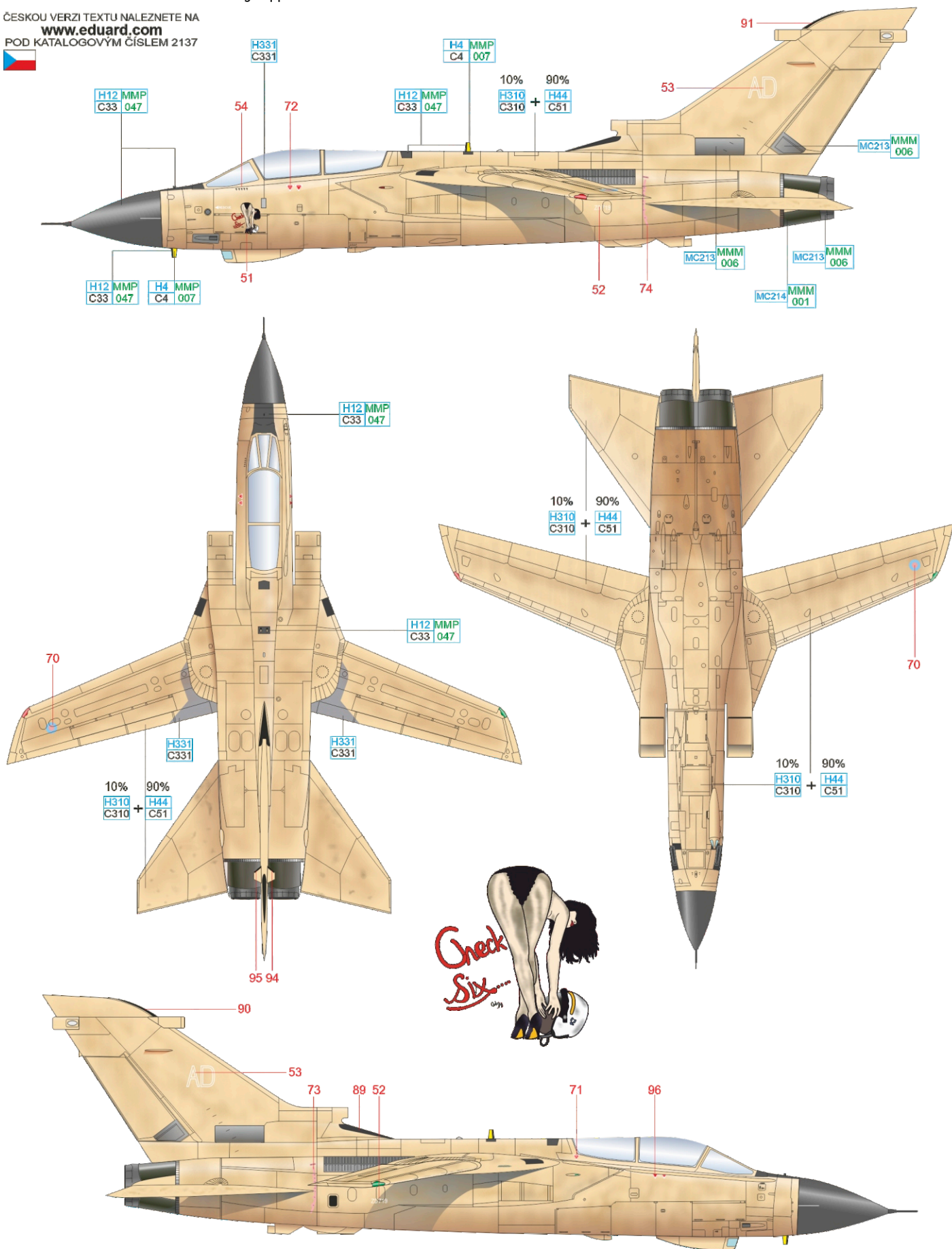

YELLOW	H4 MMP C4 007	BROWN	H310 C310	FLESH	H44 C51
BLACK	H12 MMP C33 047	DARK SEA GRAY	H331 C331	STEEL	MC213 MMM 006
					DARK IRON MC214 MMM 001

F ZD890, No. 9 Squadron, Muharraq AB, Bahrain, 1991

During the Operation Granby, Muharraq airbase in Bahrain was a home to ZD890/O, on which the ground crew painted 28 missions markings and two 'L' plates completed during the Gulf War. Same as the aircraft ZD809, this airplane carried the inscription Hello Kuwait G' Bye Iraq under the canopy as well as a reclining nude pin-up girl painting.

ČESKOU VERZI TEXTU NALEZNETE NA
www.eduard.com
 POD KATALOGOVÝM ČÍSLEM 2137

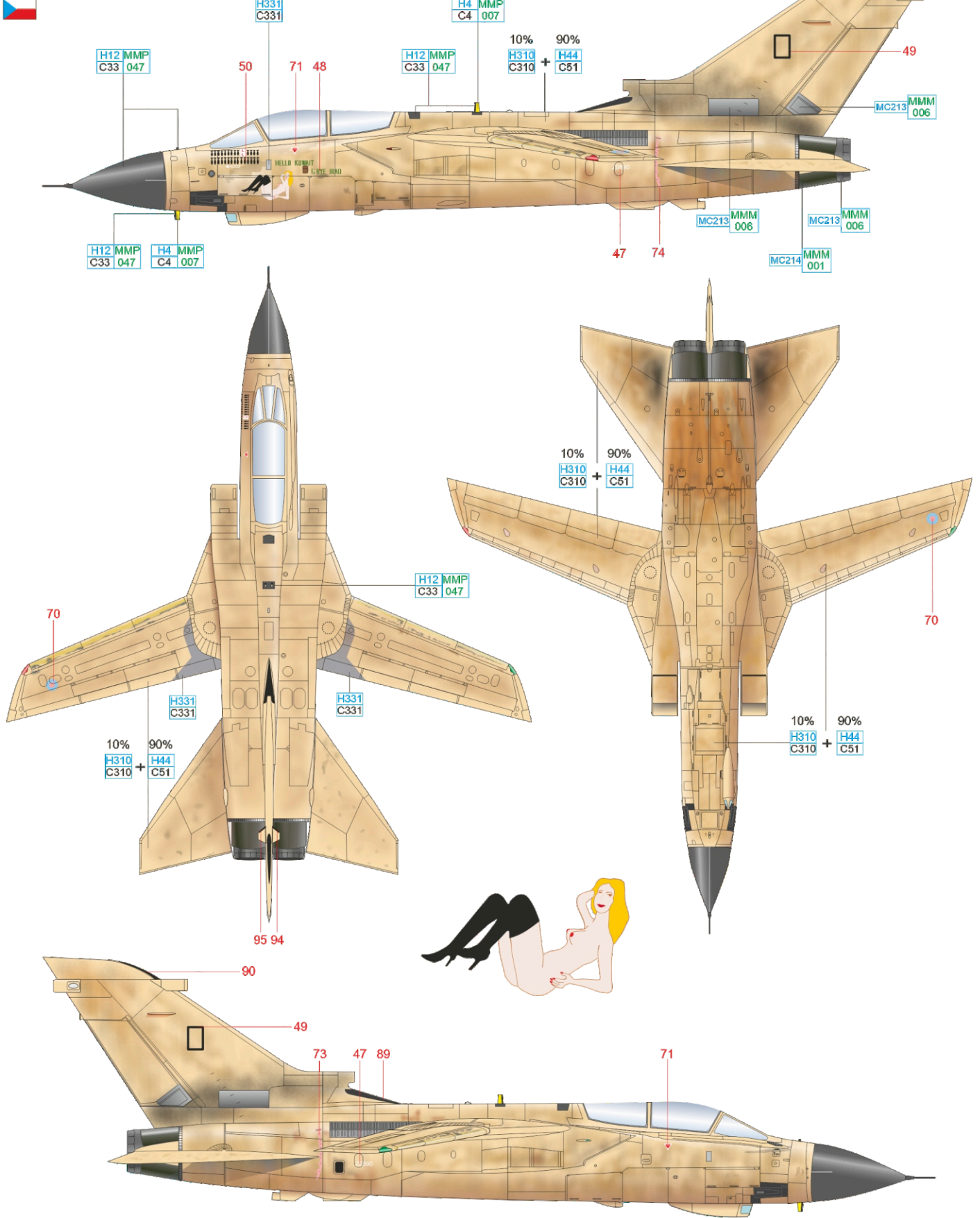

YELLOW	H4 MMP C4 007	BROWN	H310 C310	FLESH	H44 C51
BLACK	H12 MMP C33 047	DARK SEA GRAY	H331 C331	STEEL	MC213 MMM 006
				DARK IRON	MC214 MMM 001

G ZD715, Luscious Lizzie!, No. 31 Squadron, Dhahran AB, Saudi Arabia, 1991

The first twelve Tornado GR.1's, selected for Operation Granby, were deployed from RAF Brüggen airbase, located in Germany near the Holland border, to Dhahran airbase on the Saudi Arabian coast of the Persian Gulf. Led by Wg Cdr Witts, No. 31 Squadron was supplemented by elements from No. 9, No. 14 and No. 17 Squadrons and was active during the entire period of hostilities. The unit commander, Wg Cdr Jeremy Witts, was awarded DSO for his actions. ZD715/DB sported on the right fuselage side one of the most attractive pin-up girl nose art. The completed missions were marked on the same spot in the form of the bombs or palm trees.

ČESKOU VERZI TEXTU NALEZNETE NA
www.eduard.com
 POD KATALOGOVÝM ČÍSLEM 2137

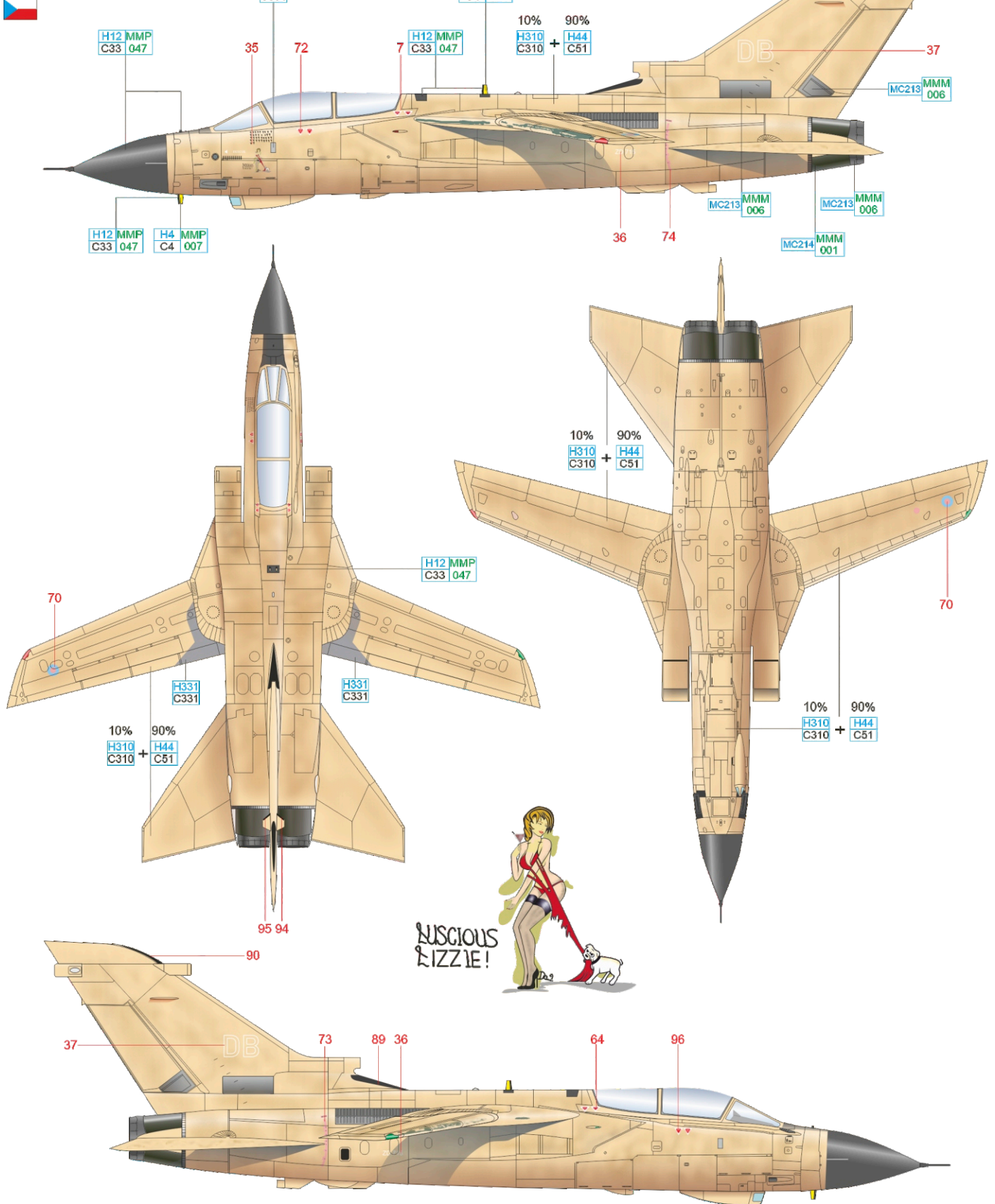

YELLOW	H4 MMP C4 007	BROWN	H310 C310	FLESH	H44 C51
BLACK	H12 MMP C33 047	DARK SEA GRAY	H331 C331	STEEL	MC213 MMM 006
				DARK IRON	MC214 MMM 001

