



Angel of Mercy



Instruction sheet

1/72

Limited Edition

2140-nav1

eduard



Carefully read instruction sheet before assembling. When you use glue or paint, do not use near open flame and use in well ventilated room. Keep out of reach of small children. Children must not be allowed to suck any part, or pull vinyl bag over the head.



Před započítím stavby si pečlivě prostudujte stavební návod. Při používání barev a lepidel pracujte v dobře větrané místnosti. Lepidla ani barvy nepoužívejte v blízkosti otevřeného ohně. Model není určen malým dětem, mohlo by dojít k požití drobných dílů.

INSTRUCTION SIGNS * INSTR. SYMBOLS * INSTRUKTION SINNBILDEN * SYMBOLES * 記号の説明

OPTIONAL
VOLBABEND
OHNOUTSAND
BROUSITOPEN HOLE
VYVRTAT OTVORSYMETRICAL ASSEMBLY
SYMETRICKÁ MONTÁŽREMOVE
ODŘÍZNOUTREVERSE SIDE
OTOČITAPPLY EDUARD MASK
AND PAINT
POUŽIT EDUARD MASK
NABARVIT

PARTS

* DÍLY

* TEILE

* PIÈCES

* 部品

PLASTIC PARTS

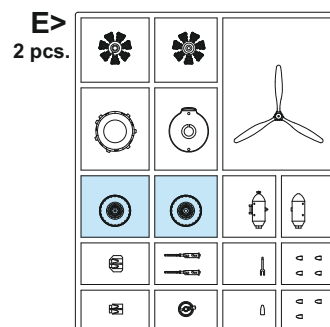
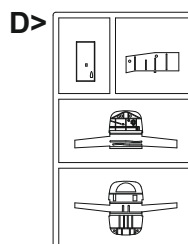
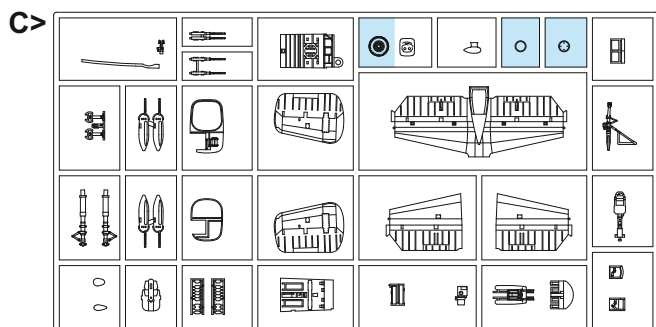
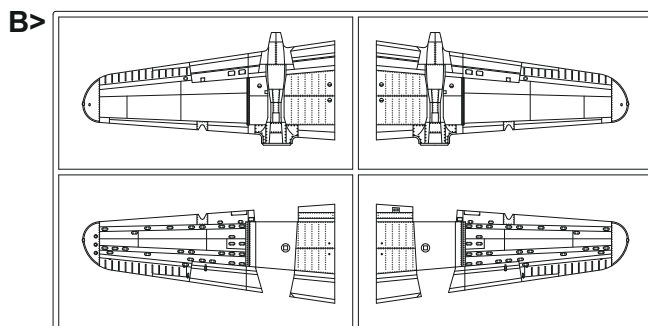
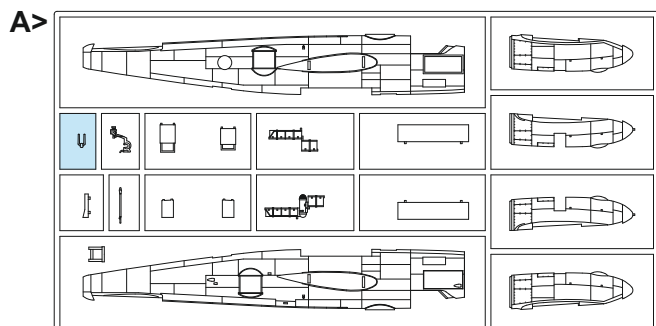

PE - PHOTO ETCHED DETAIL PARTS

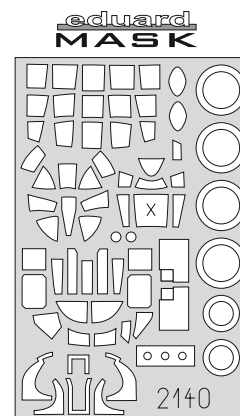
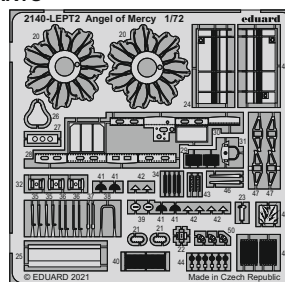
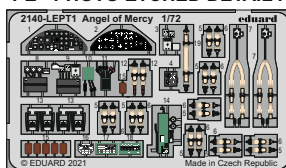
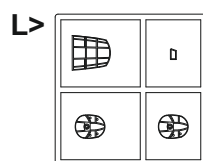
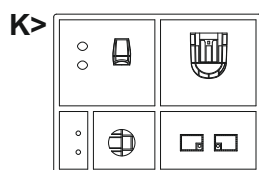

eduard BRASSIN RP - RESIN PARTS

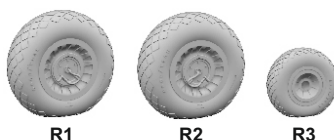
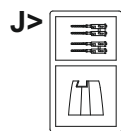
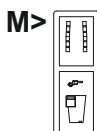

R1

R2

R3

-Parts not for use. -Teile werden nicht verwendet. -Pièces à ne pas utiliser. -Tyto díly nepoužívejte při stavbě. - 使用しない部品

COLOURS

* BARVY

* FARBEN

* PEINTURE

* 色

GSI Creos (GUNZE)		MISSION MODELS	
AQUEOUS	Mr.COLOR	PAINTS	
H4	C4	MMP-007	YELLOW
H5	C5	MMP-048	BLUE
H6	C6	MMP-004	GREEN
H8	C8		SILVER
H11	C62	MMP-001	FLAT WHITE
H12	C33	MMP-047	FLAT BLACK
H47	C41	MMP-012	RED BROWN
H52	C12	MMP-091	OLIVE DRAB
H53	C13		NEUTRAL GRAY

GSI Creos (GUNZE)		MISSION MODELS	
AQUEOUS	Mr.COLOR	PAINTS	
H58	C351	MMP-059	INTERIOR GREEN
H77	C137	MMP-040	TIRE BLACK
H327	C327	MMP-101	RED
H329	C329	MMP-041	YELLOW
Mr.METAL COLOR		METALLICS	
MC213		MMM-008	STEEL
MC214		MMM-001	DARK IRON
Mr.COLOR SUPER METALLIC		METALLICS	
SM201		MMC-001	SUPER FINE SILVER

INTERIOR COLOR - BARVA INTERIÉRU

INTERIOR

90% + 10%

[H58 MMP C351 059] INT. GREEN

[H12 MMP C33 047] FLAT BLACK

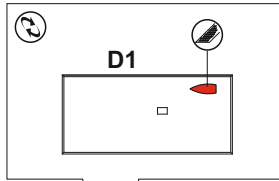

A 2 pcs.

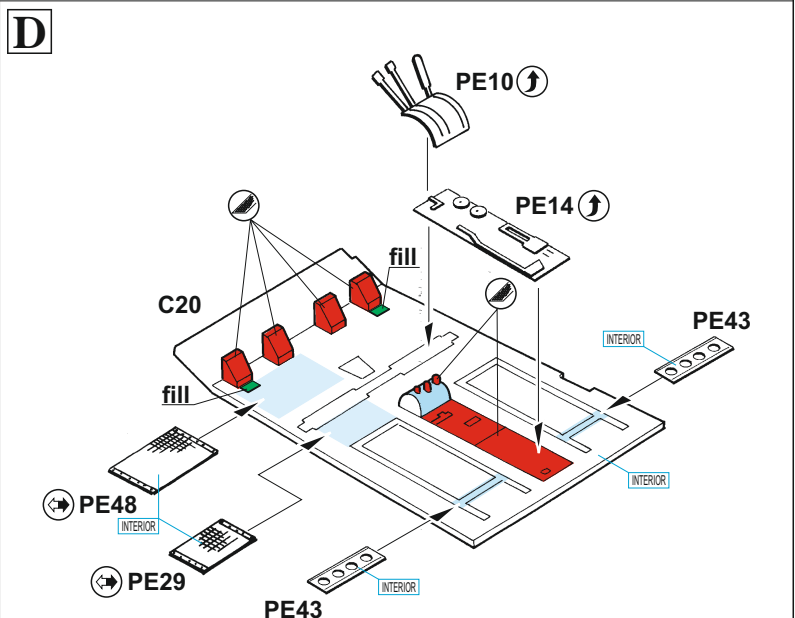
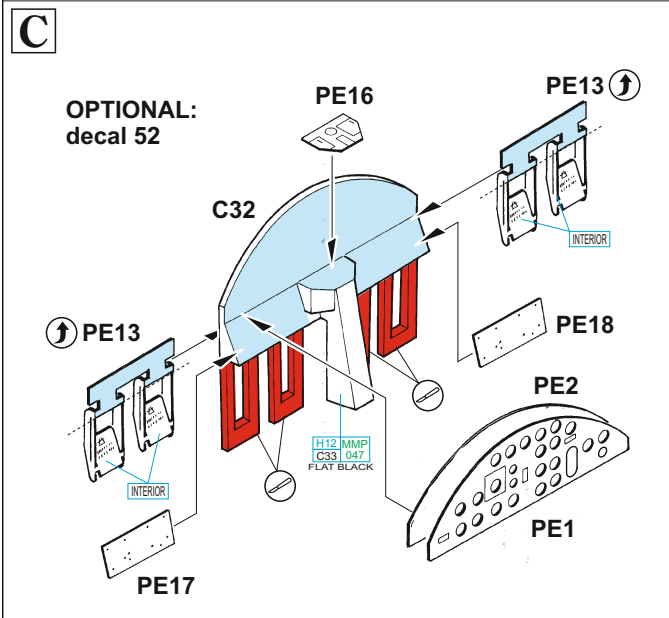
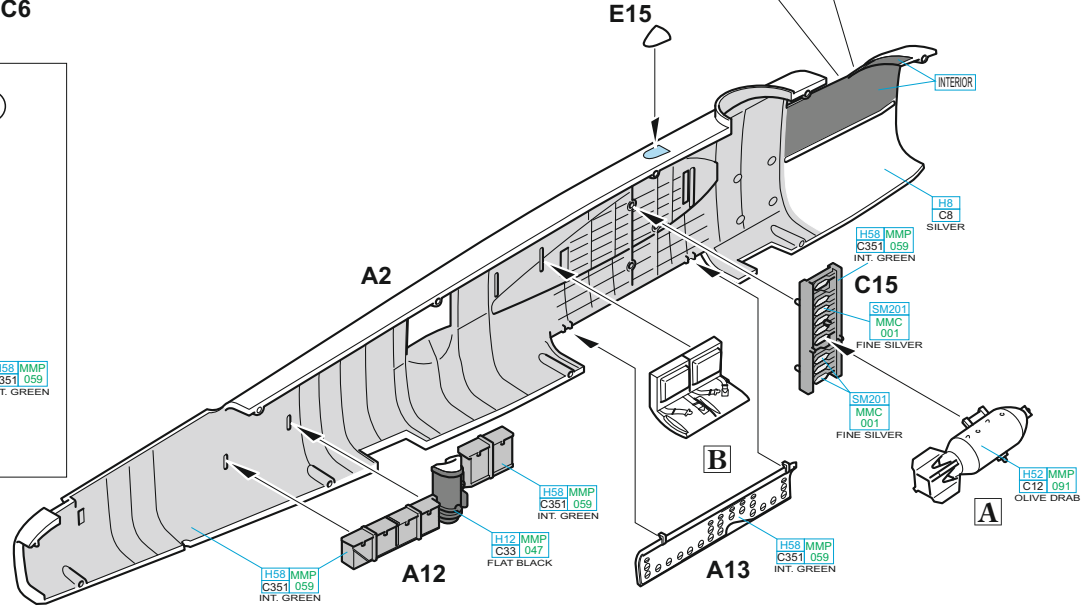
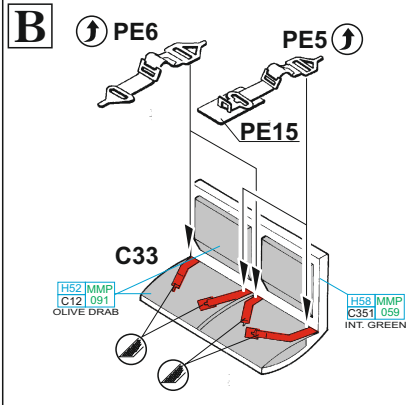
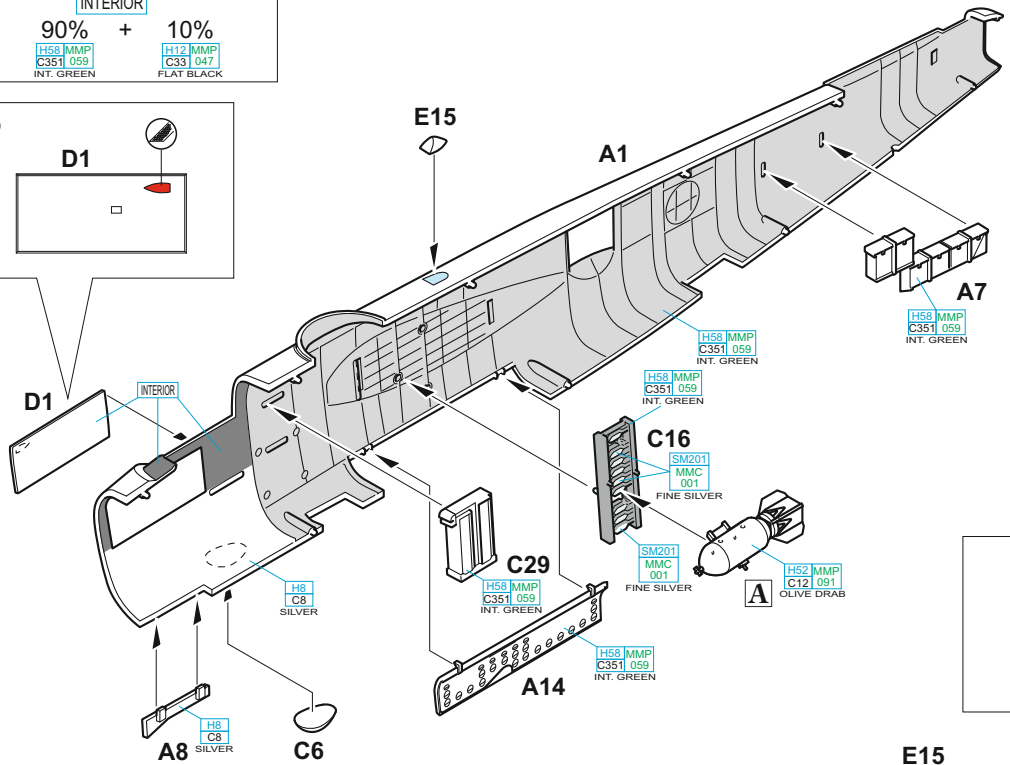
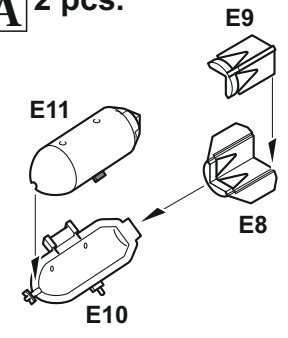

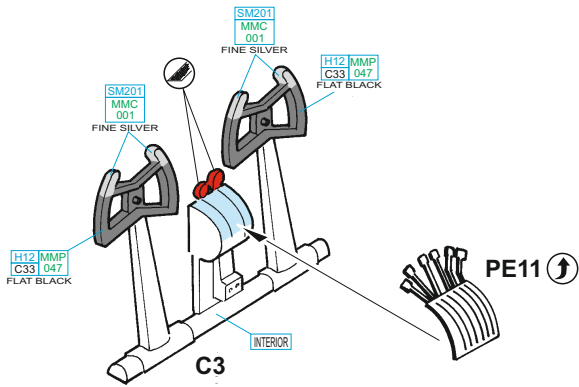
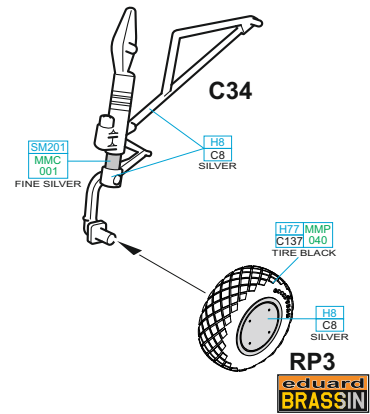
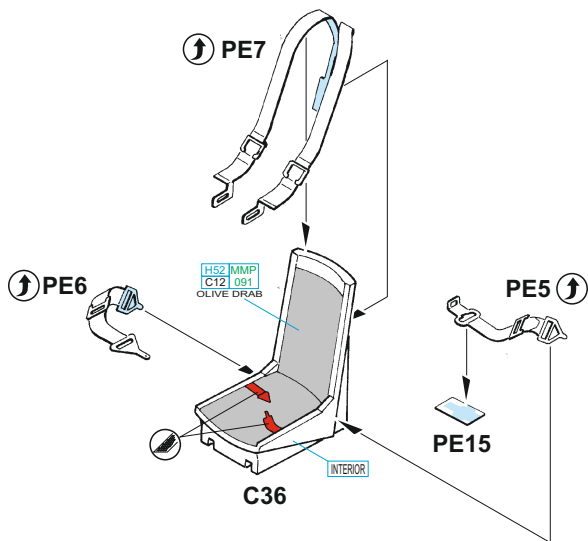
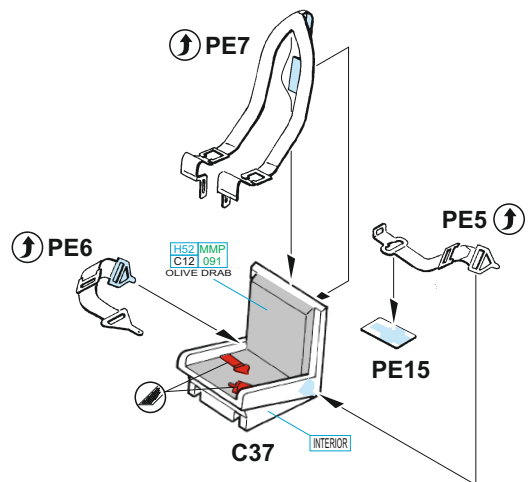
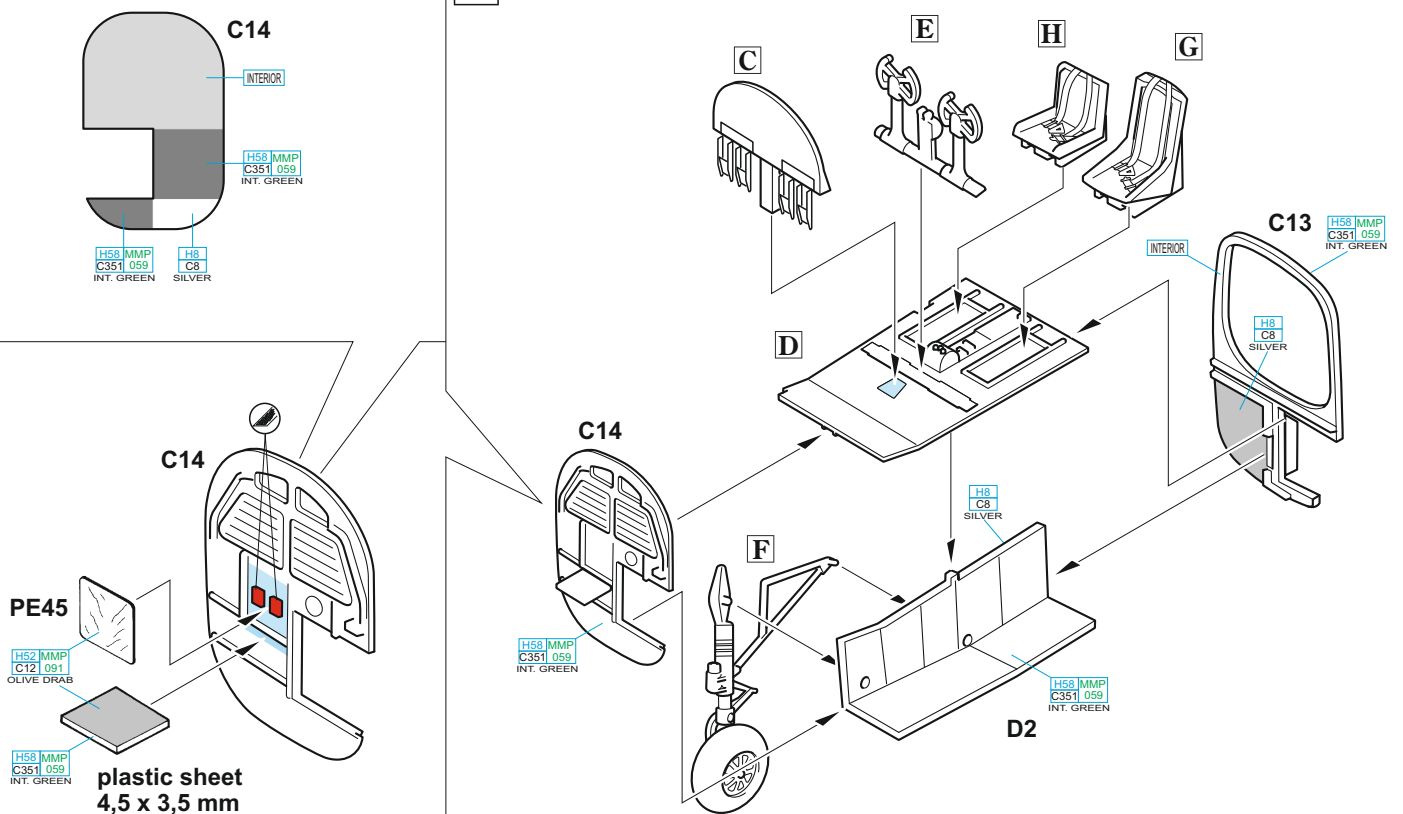
E**F****G****H****4****I**

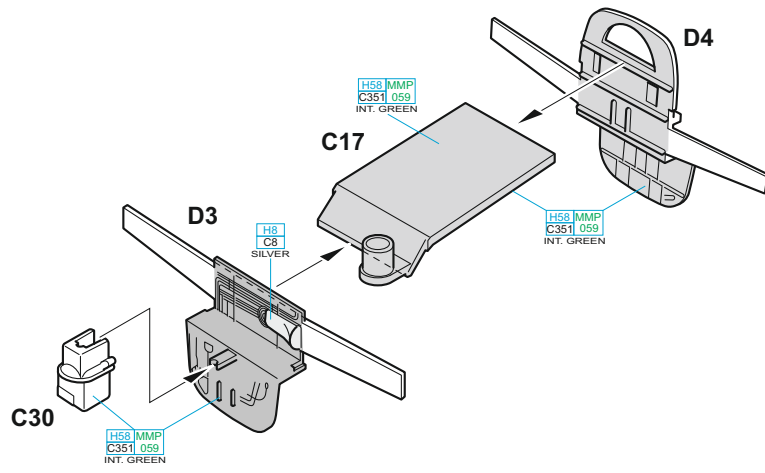
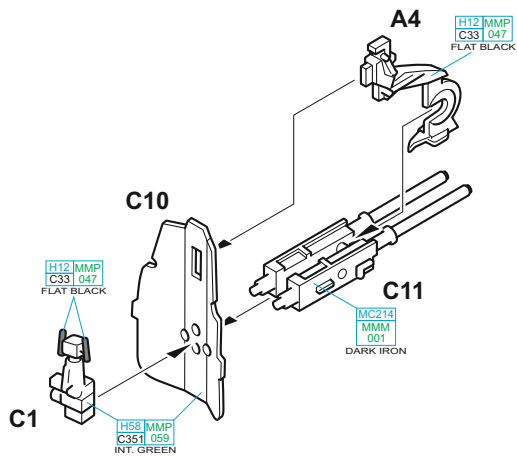
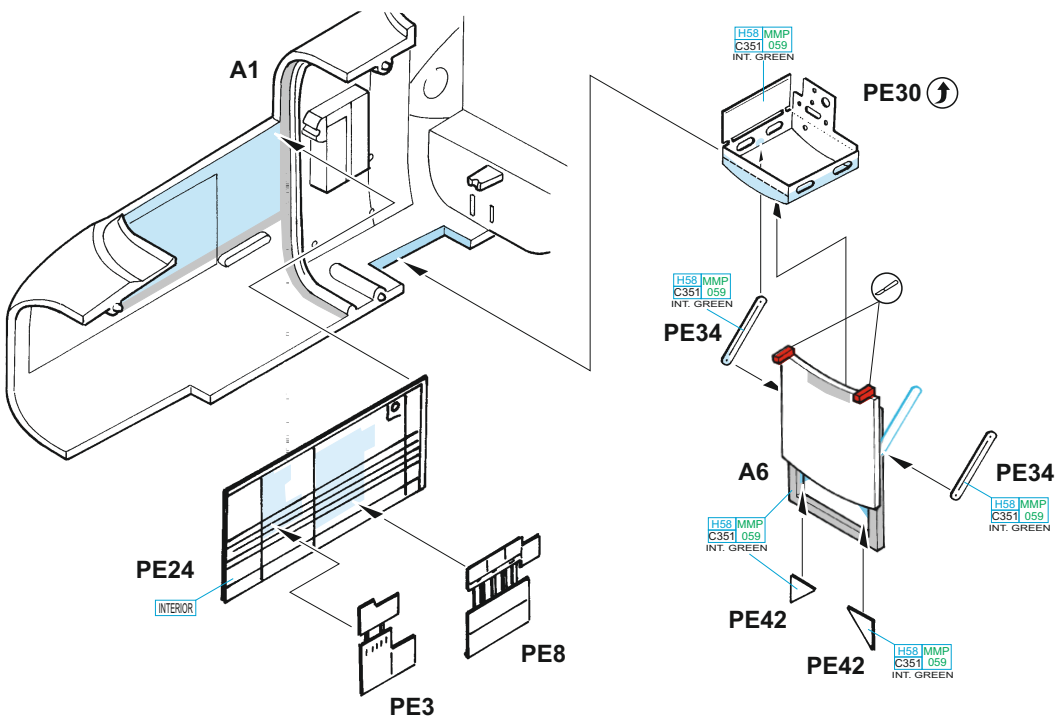
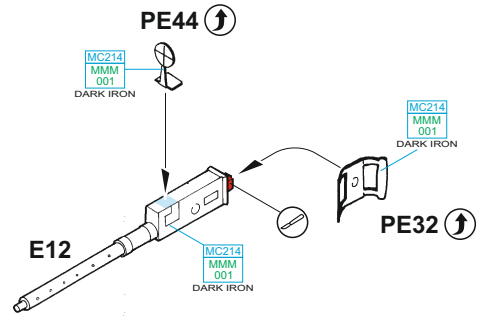
J**K****L** 3 pcs.

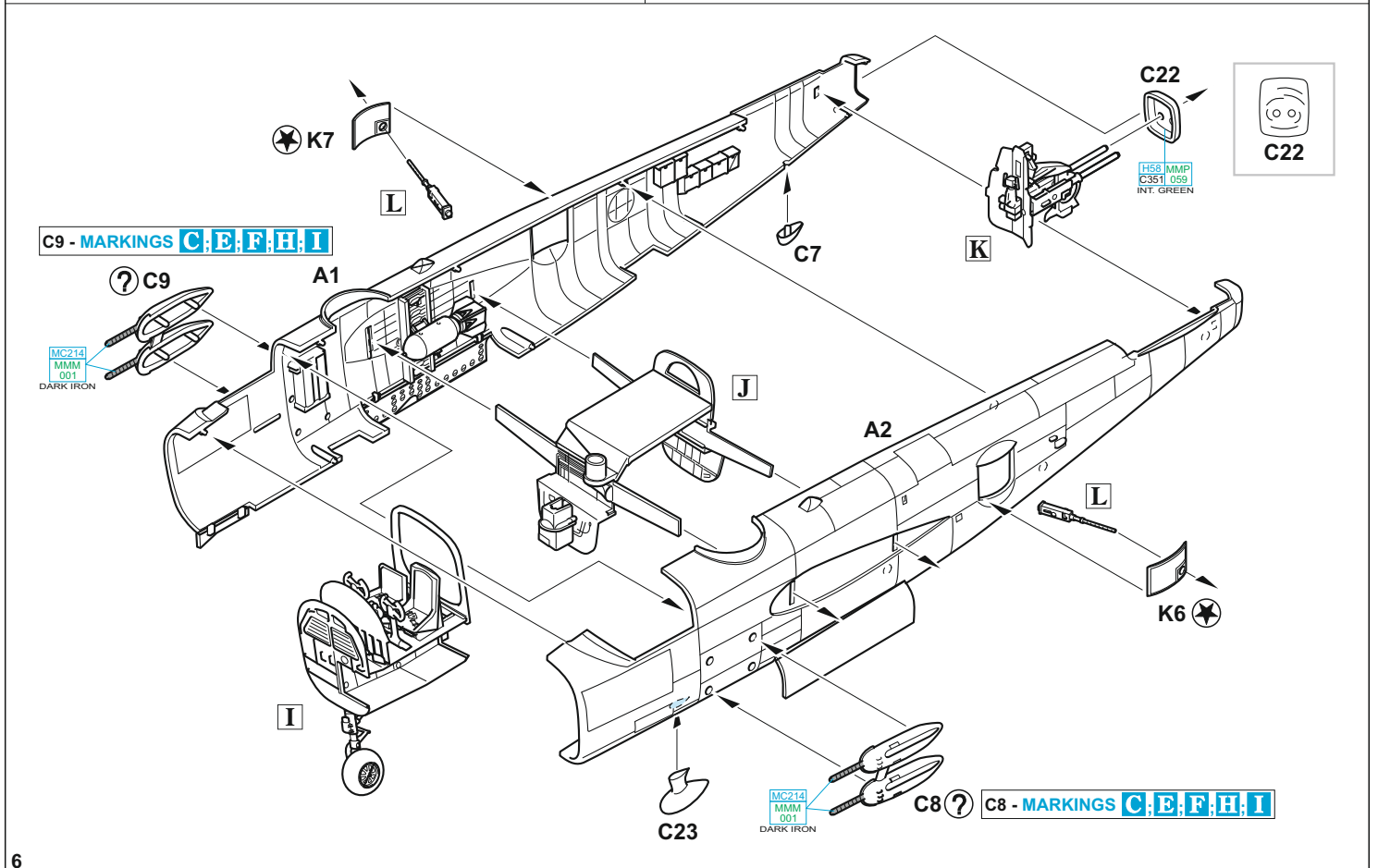
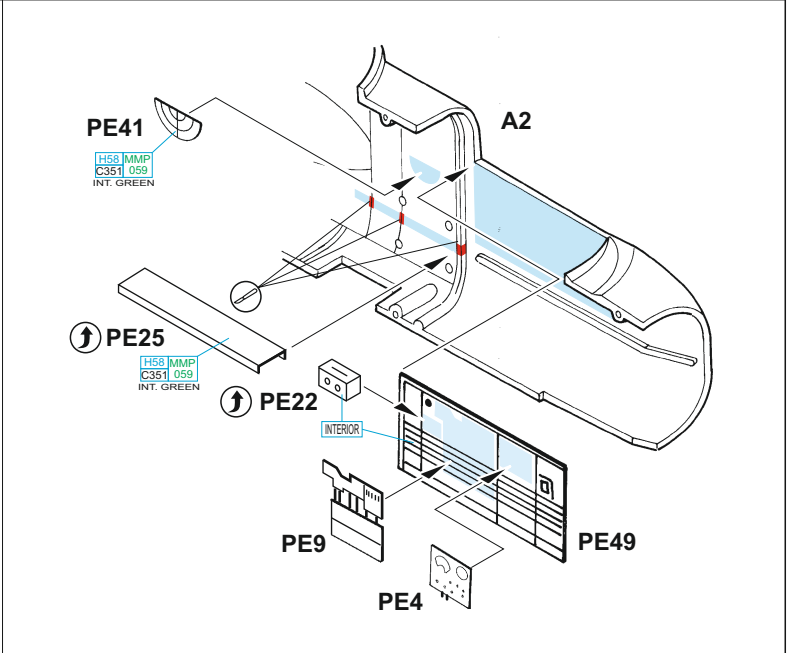
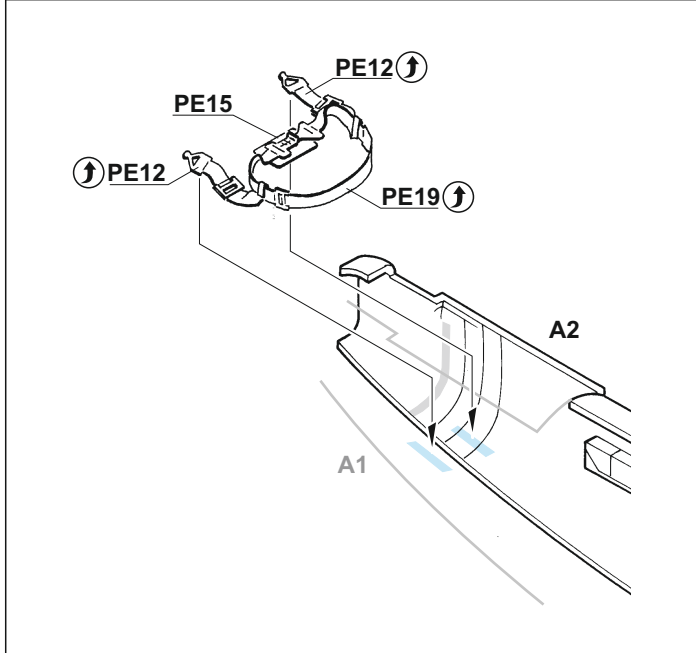
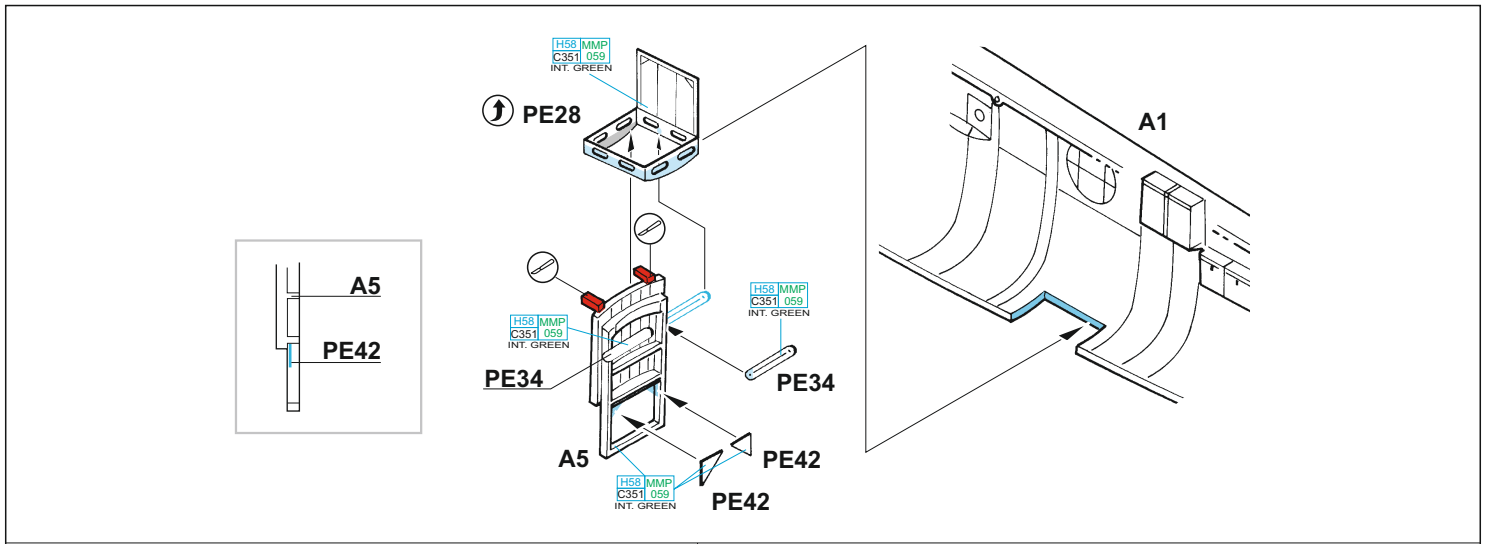

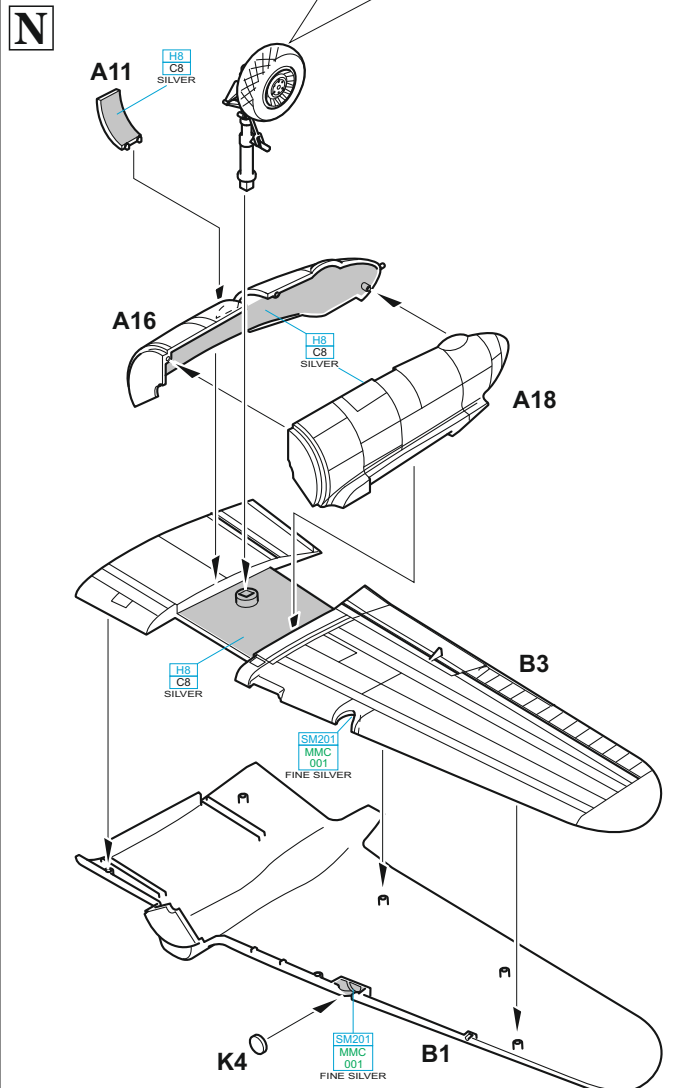
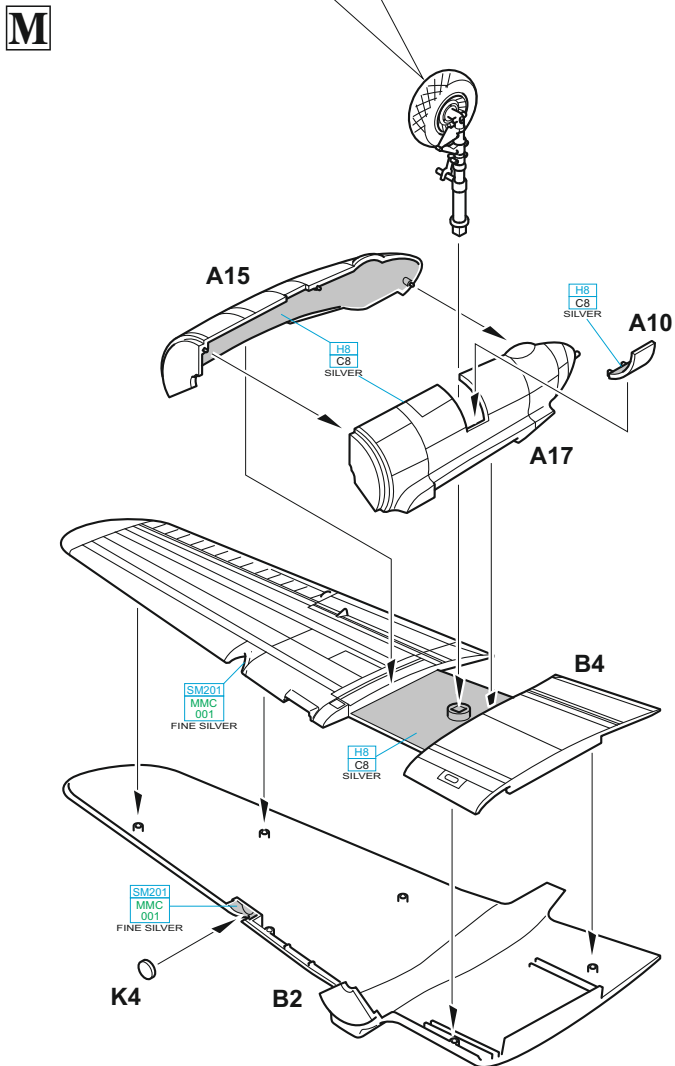
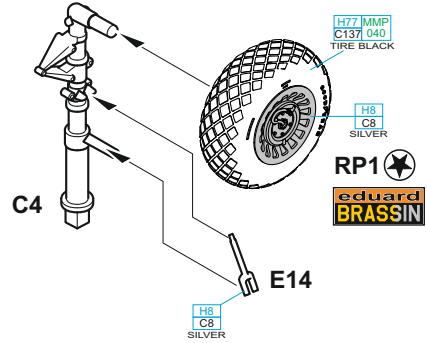
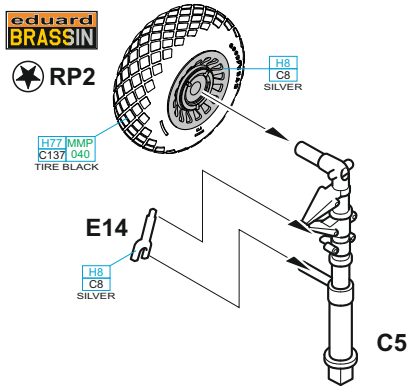
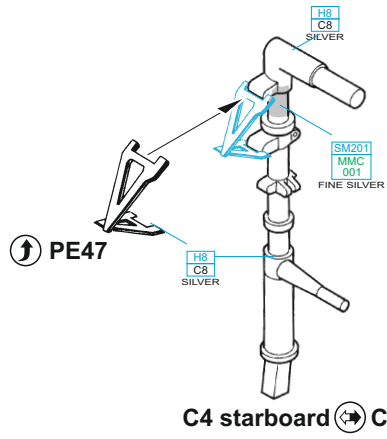
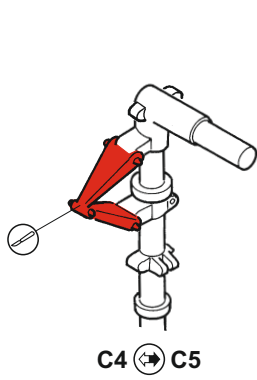

O 2 pcs.

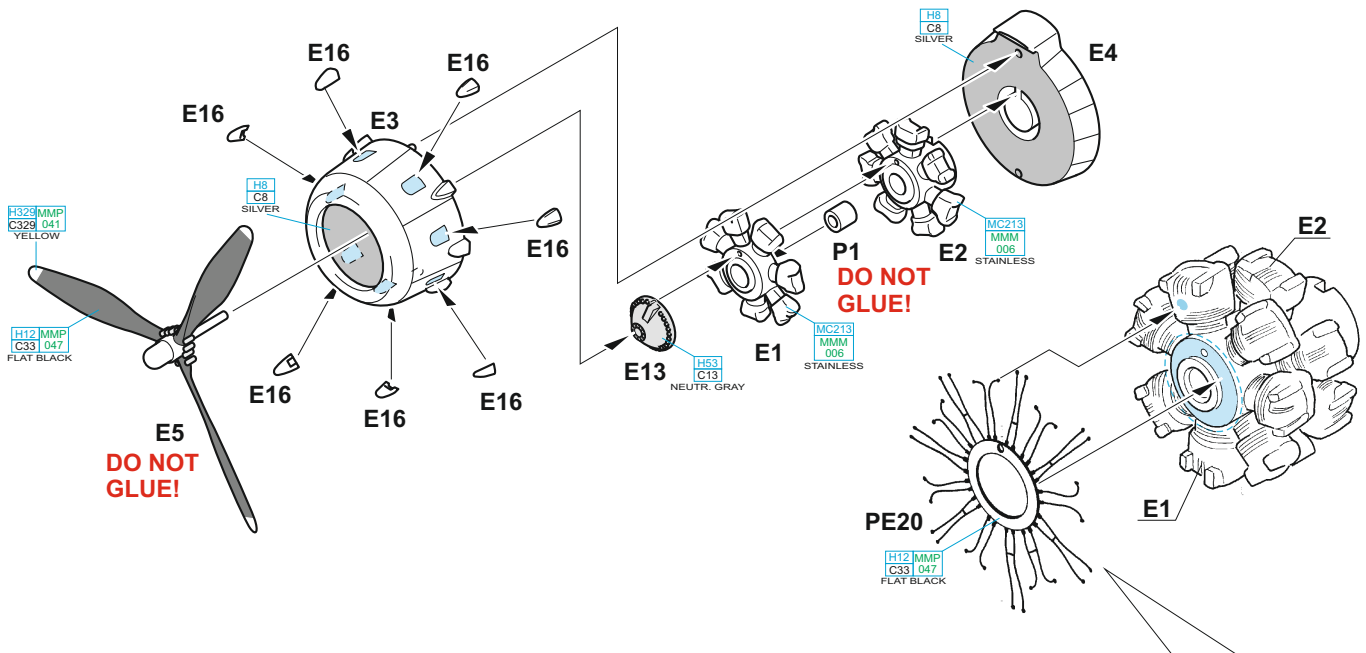

P

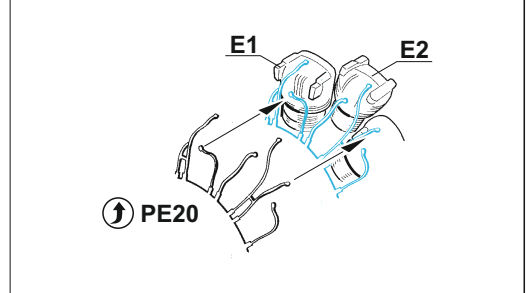
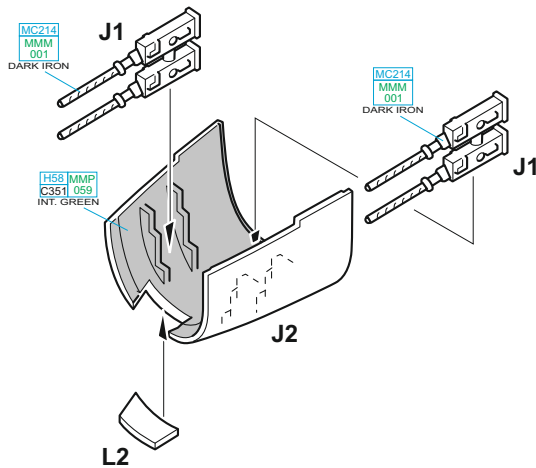

M2 port side → M1 starboard

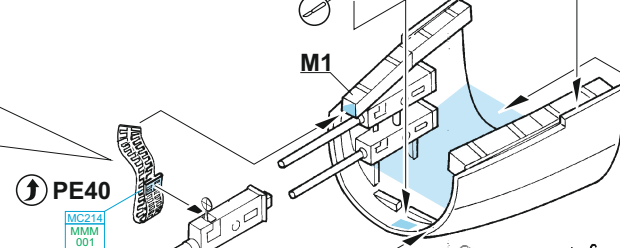
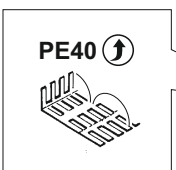
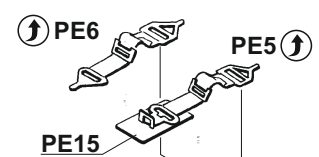
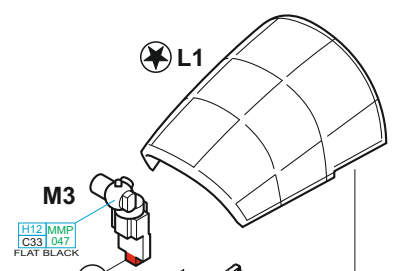
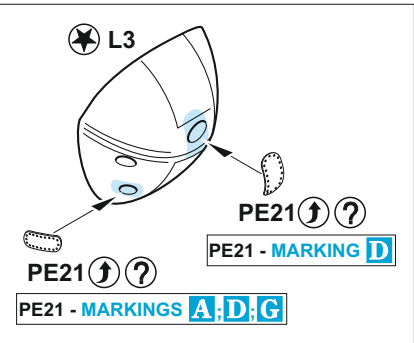
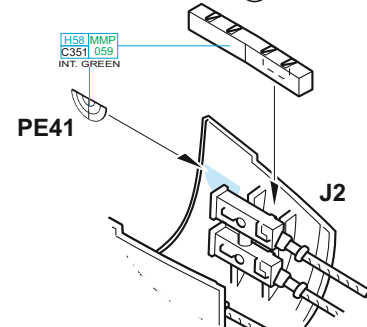

Don't forget to add the nose weight balance!

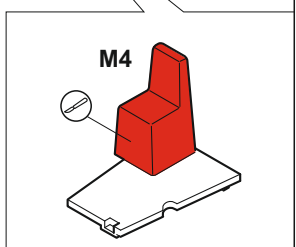
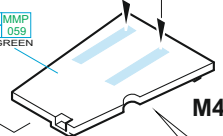

L3 - MARKINGS **A;B;D;E;G;H;I;J**

L4 - MARKINGS **C;F**

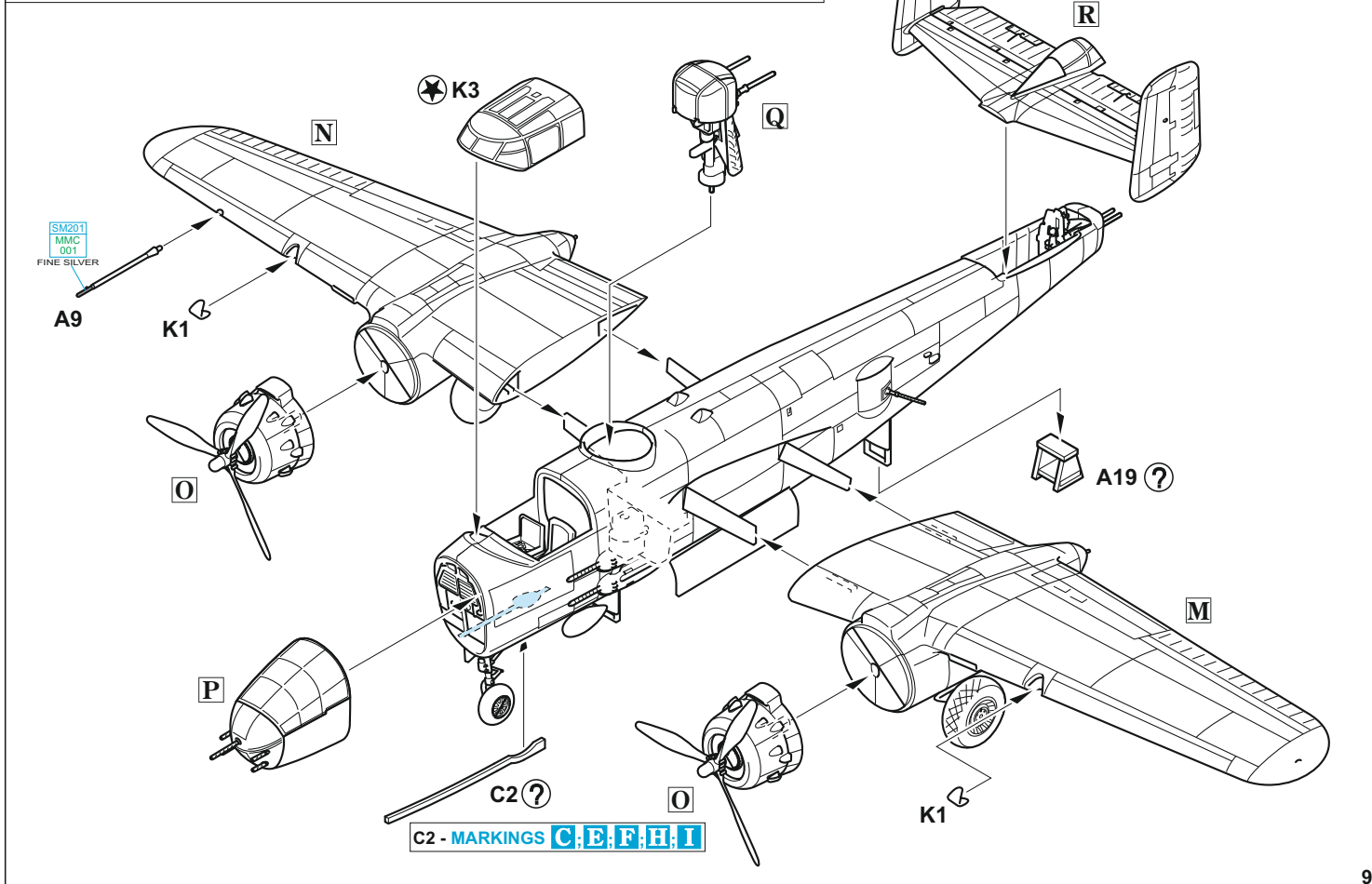
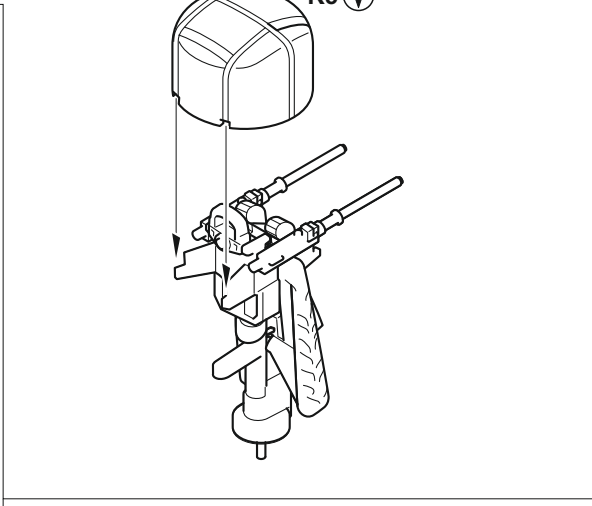
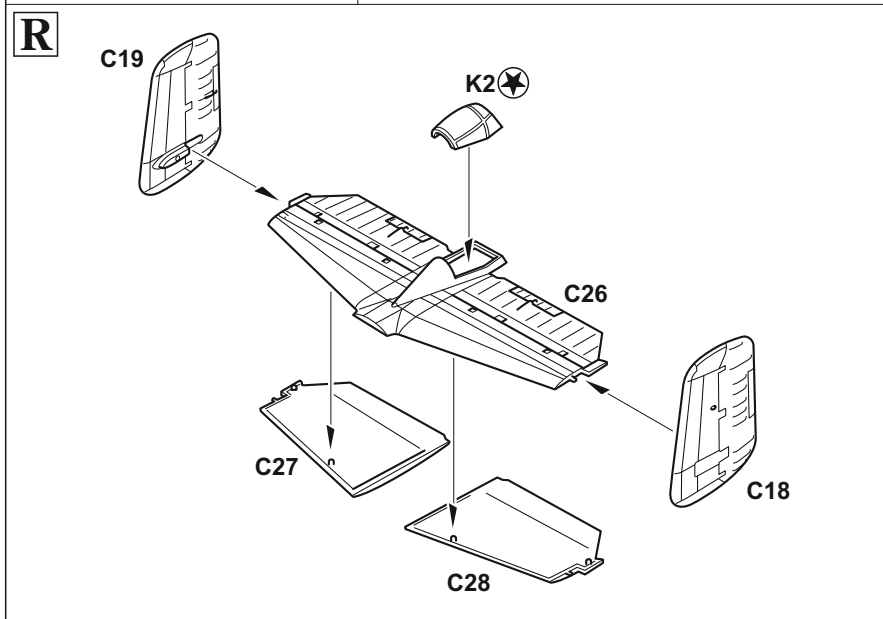
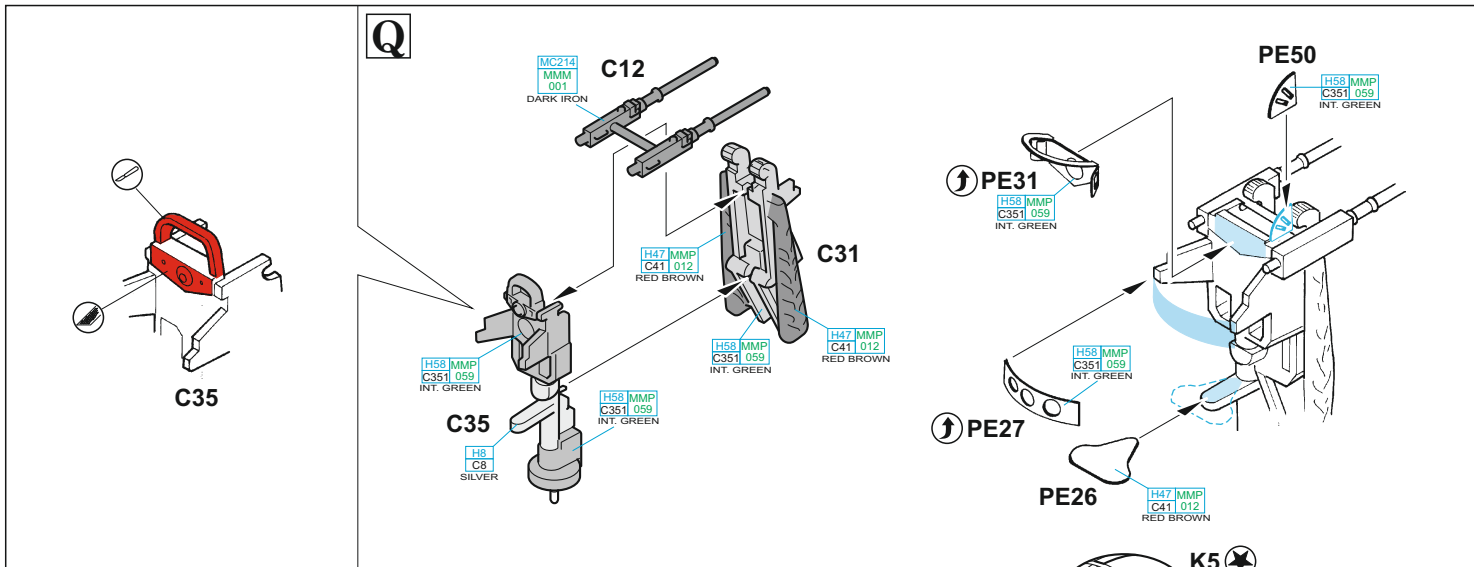

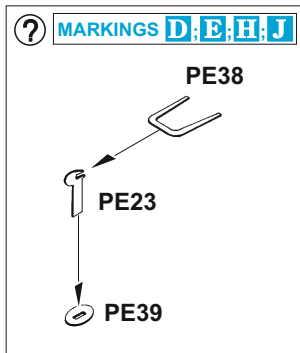
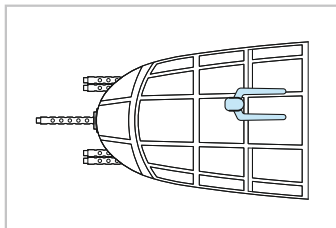
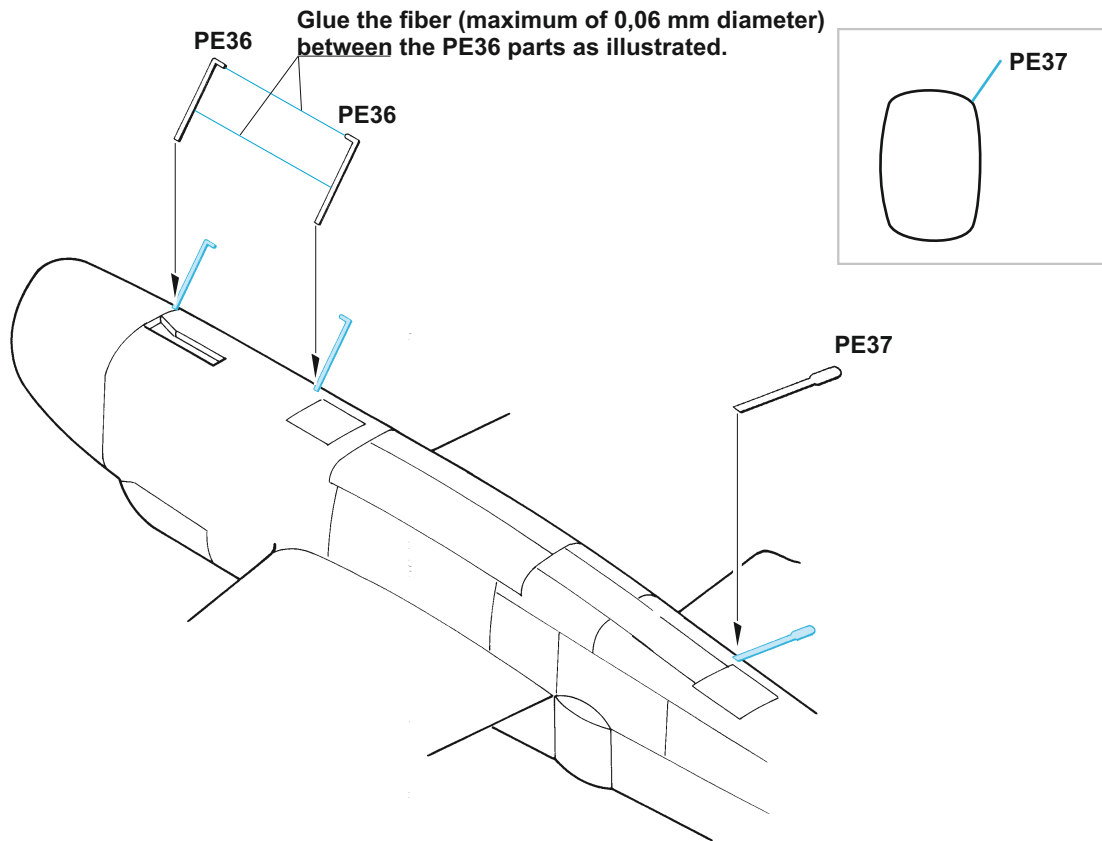

H12 MMP
C33 047
FLAT BLACK

Glue the fiber (maximum of 0,06 mm diameter) between the PE35 ends and the upper of the leading edges of the vertical stabilizers.

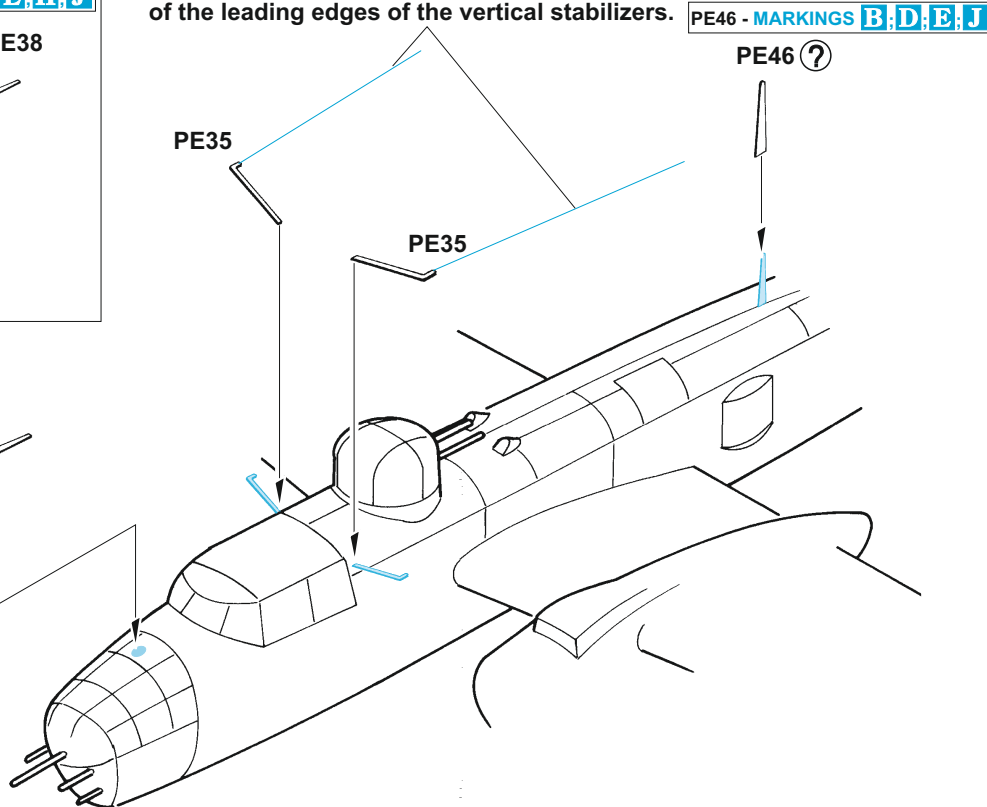

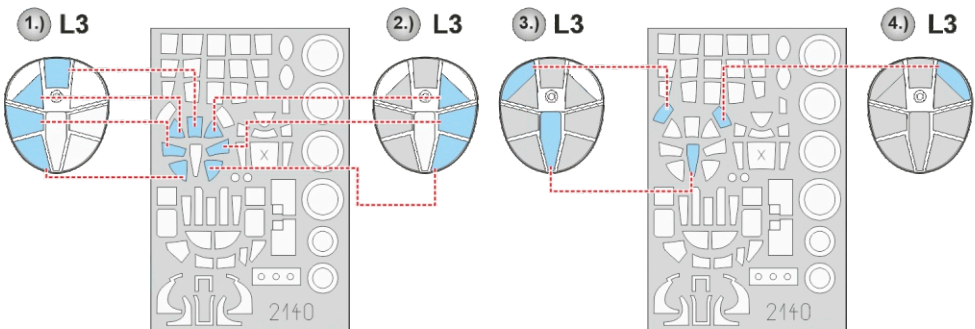
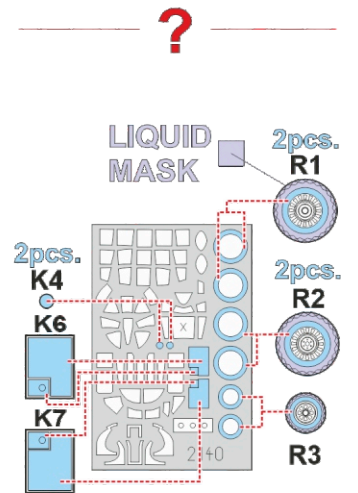
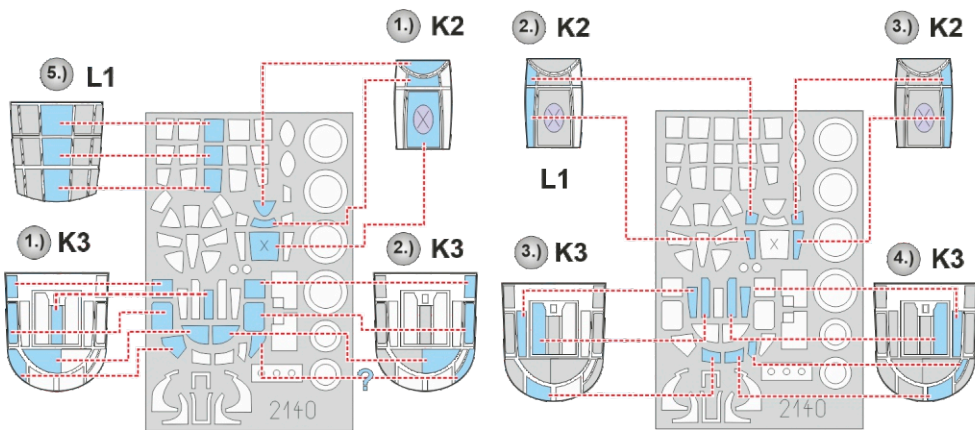
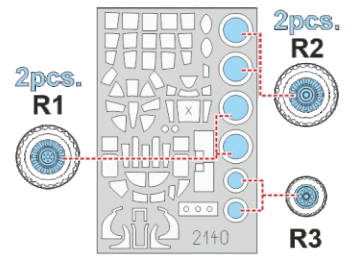
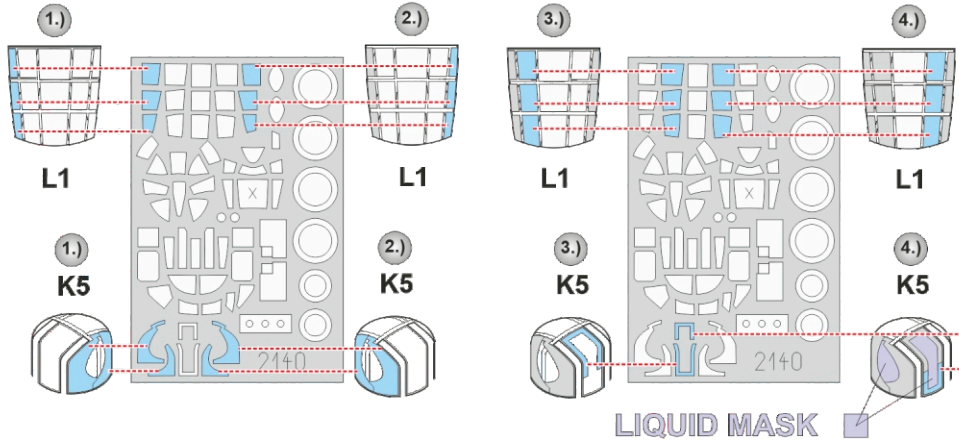
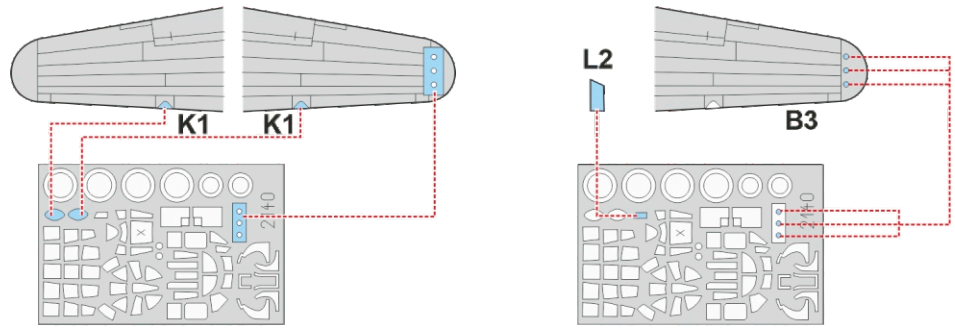

1.) INTERIOR COLOR



2.) CAMOUFLAGE COLOR



3.) REMOVE MASK

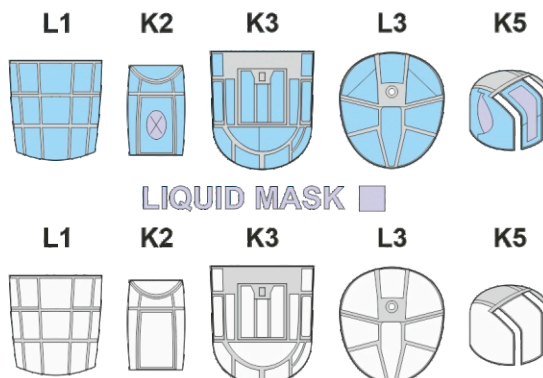

A B-25J-10-NC, 43-35982, 428th BS, 310th BG, 12th AF, Ghisonaccia, Corsica, France, April 1945

The 310th Bombardment Group was activated in March 1942 and designated as a medium bomber Group consisting of four squadrons. Delivered in June 1944, the 43-35982 ship nicknamed "Angel of Mercy" was flying with the 428th bomb squadron. She was one of 15 aircraft of the unit to fly the mission to the Rovereto on April 19, 1945. She was hit by shell fragments from AA fire and badly damaged prior to the bomb dropping. Pilot-in-command, 1/Lt. W. S. McMillan managed to keep the ship on course with help of his co-pilot W. D. McLean, enabling the bombardier to drop the bombs on the target, the railroad bridge. The hits knocked out the hydraulic system and main gear, rear gunner A. S. Hatfield was wounded. The crew decided not to risk the overseas flight to the home base at Corsica and opted for another base of the 310th BG at Fano, Italy, where they managed to land the ship with only nose landing gear open. The "Angel of Mercy" ship was left in natural metal finish, so it had the horizontal band on the vertical tail surfaces separated by black bands. The colors for 310th BG as well as for the 428th BS were yellow. The propeller spinner and the front of the engine covers were of the same color. The nose art of the nurse with a bomb under her arm was not accompanied by mission symbols on this aircraft.

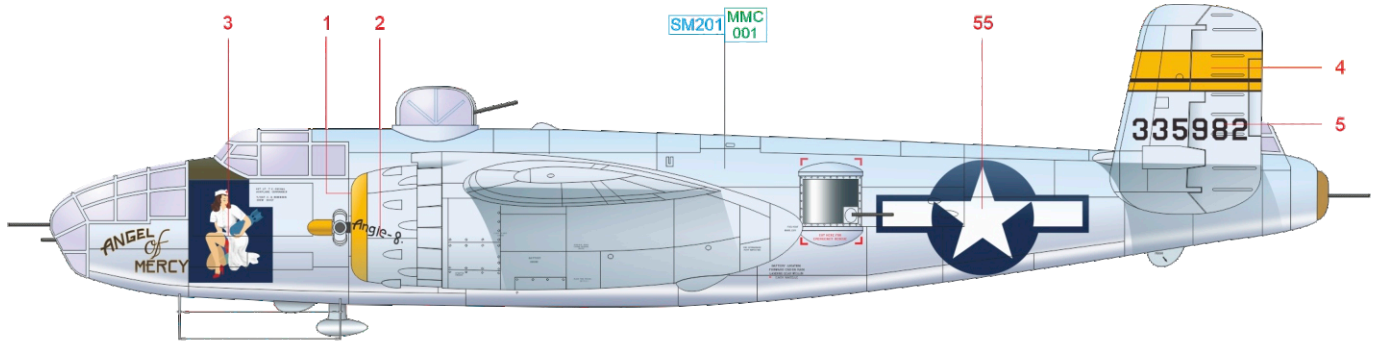

ČESKOU VERZI TEXTU NALEZNETE NA
www.eduard.com
 POD KATALOGOVÝM ČÍSLEM 2140

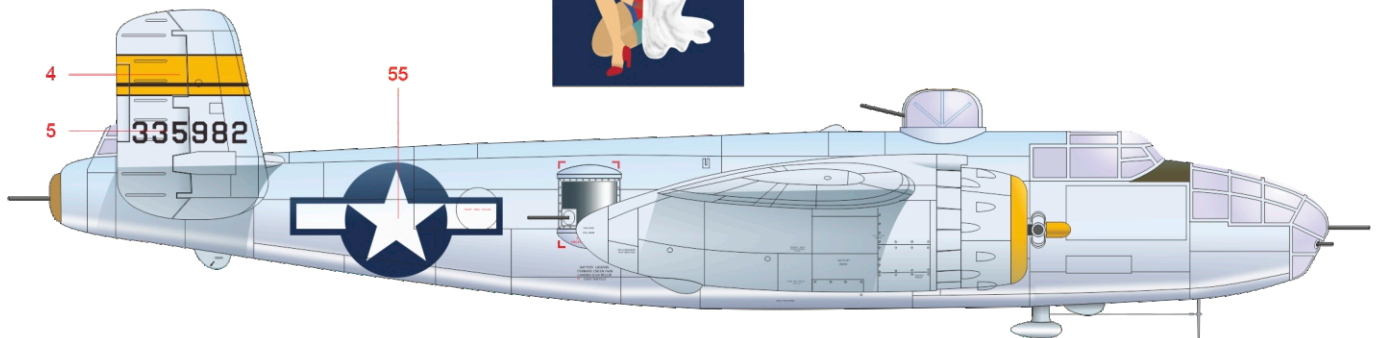
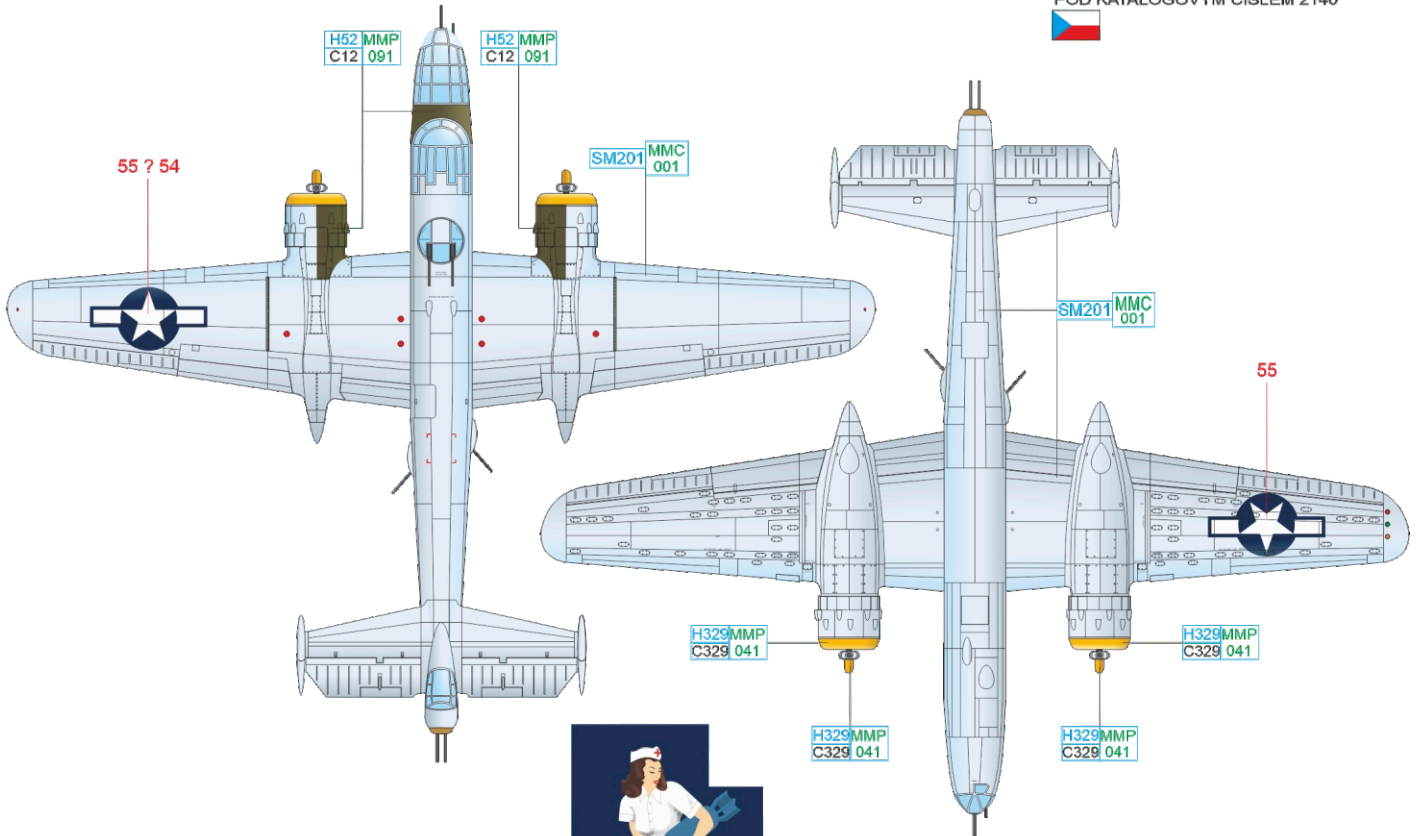

OLIVE DRAB	H52 MMP C12 091	ORANGE YELLOW	H329 MMP C329 041	SUPER FINE SILVER	SM201 MMC 001
------------	-----------------	---------------	-------------------	-------------------	---------------

B B-25J-1-NC, 43-27716, 445th BS, 321st BG 12th AF, Solenzara, Corsica, France, April 1945

Constituted as 321st Bombardment Group (Medium) on June 19, 1942 and activated on June 26, the crews of the unit prepared for overseas duty with B-25s. The 43-27716 ship got rather amusing nickname "Shit house mouse" and had the missions marked by black mice. On the engine cowl there was an inscription "Quakatown" (the town in Pennsylvania). The pilot of the ship and the Airplane Commander was 1/Lt. R. S. Elmer from December 1, 1944, to March 29, 1945. On the March 30 Elmer overhanded her to 1/Lt. R. G. Rice, who brought "Shit house mouse" to the end of the war. Until its 73rd mission the aircraft had only the Roman numeral I on the tail, after then Latin number 7 was added on the vertical fin on December 14, 1944. The ship sported Olive Drab color over the upper and side surfaces, as was a common practice. Other surfaces were left in natural metal finish. The outhouse was of brown color.

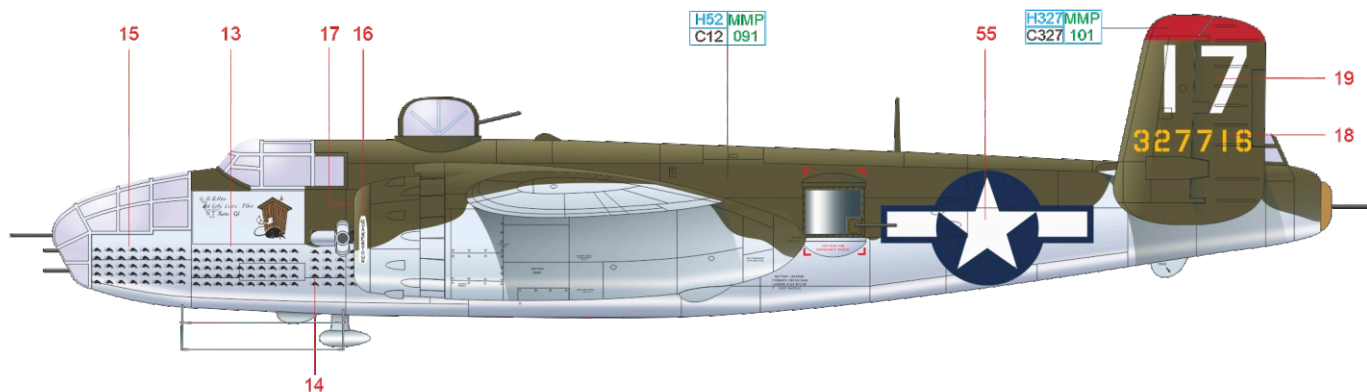

ČESKOU VERZI TEXTU NALEZNETE NA
www.eduard.com
 POD KATALOGOVÝM ČÍSLEM 2140

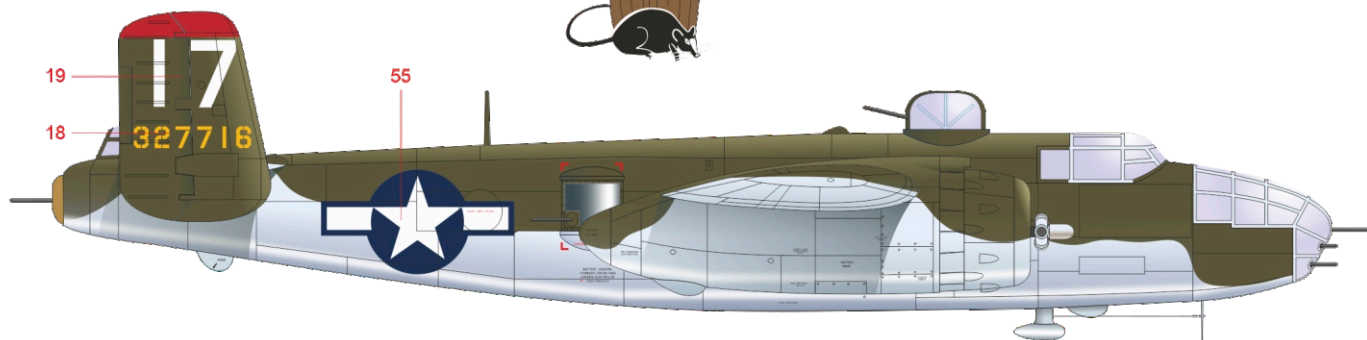
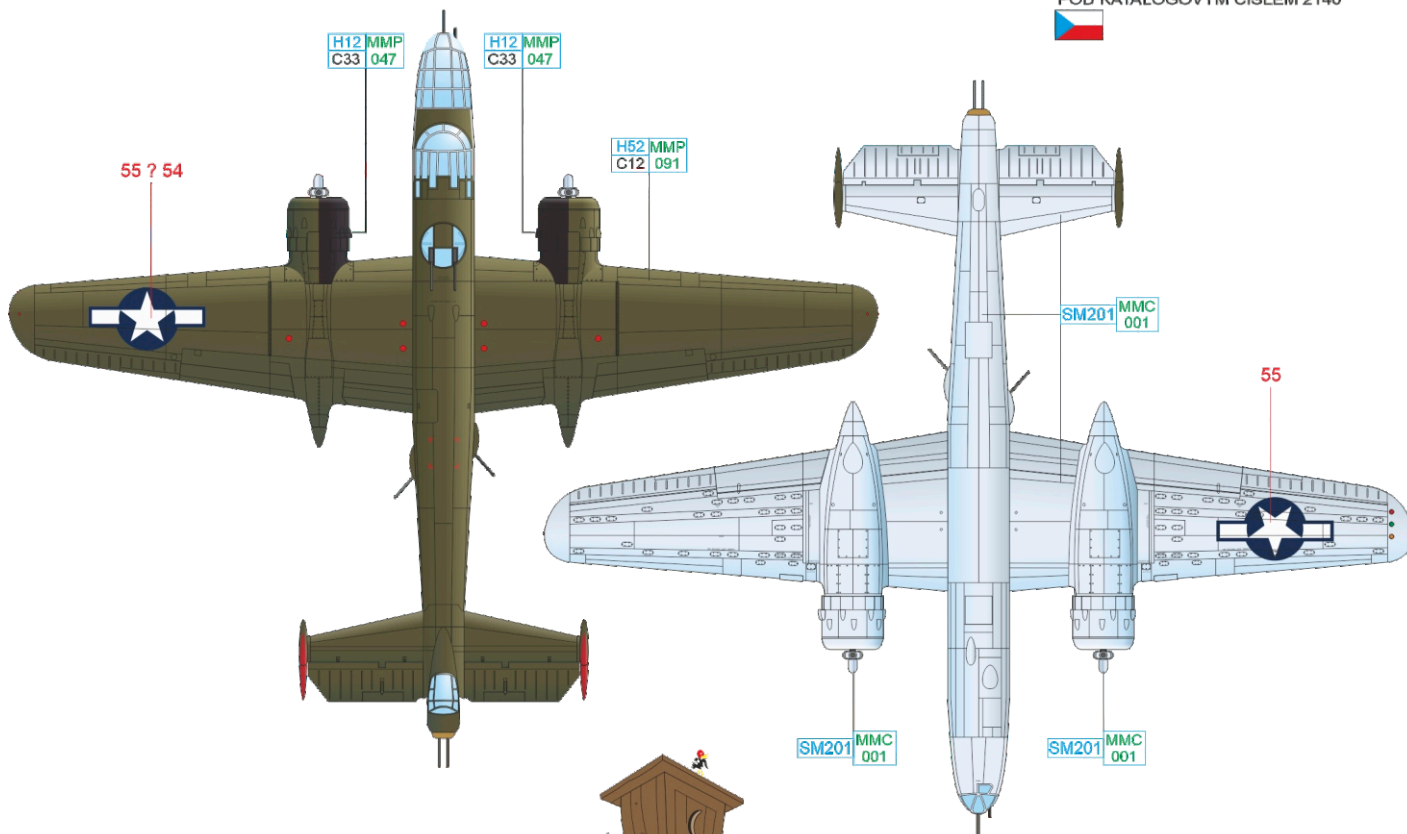

OLIVE DRAB H52 MMP C12 091 RED H327 MMP C327 101 BLACK H12 MMP C33 047 SUPER FINE SILVER SM201 MMC 001

eduard

The 345th Bomb Group was first activated at Columbia Army AB in November 1942 and was christened the "Air Apaches" in July 1944. It was the first Air Force Combat Group to be sent to the Pacific in WWII. The group consisted of four squadrons, as usual with the medium bomber groups, one of them, the 501st squadron, had the nickname "Black Panthers". The 43-28152 was assigned to the unit on October 22, 1944, and shortly afterwards nicknamed "Apache Princess" and assigned to pilot Roman Ohnemus. The ship was lost on May 27, 1945, when piloted by 2/Lt Ted. U. Hart on the mission against Ensui airfield and rail yard on Formosa. Due to a navigational error and bad weather the squadron missed the target and attacked sugar refinery and a brick plant at Mizukami and Meiji instead. The "Apache Princess" was hit by AA fire during attack and her left engine caught fire. After releasing the bombs, Hart feathered the damaged engine, but the fire spread to the bomb bay and the aircraft crash landed into the rice field. SSgt. Robert E. Bever was fatally wounded, the rest of the crew survived and became POW. There is no photo evidence of the port side of the ship, it is believed the beautiful and large nose art was only on the starboard side (although the warbird with both sides painting of heavily modified theme exists). The original painting was a masterpiece of work of gifted Sgt. George M. Blackwell. The aircraft sported the older variant of the Group's badge, the head of the Indian. It is possible it might be already replaced by later simplified badge at the time it reached its sour end.

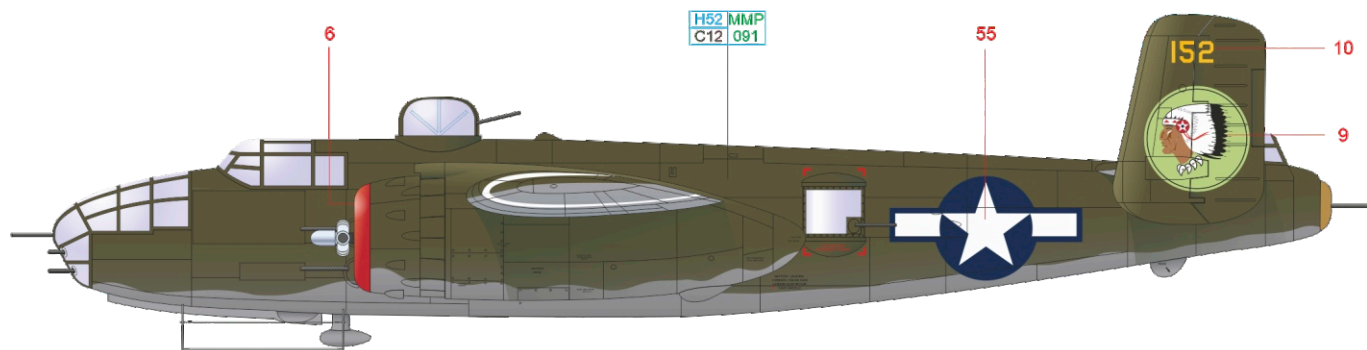

ČESKOU VERZI TEXTU NALEZNETE NA www.eduard.com
POD KATALOGOVÝM ČÍSLEM 2140

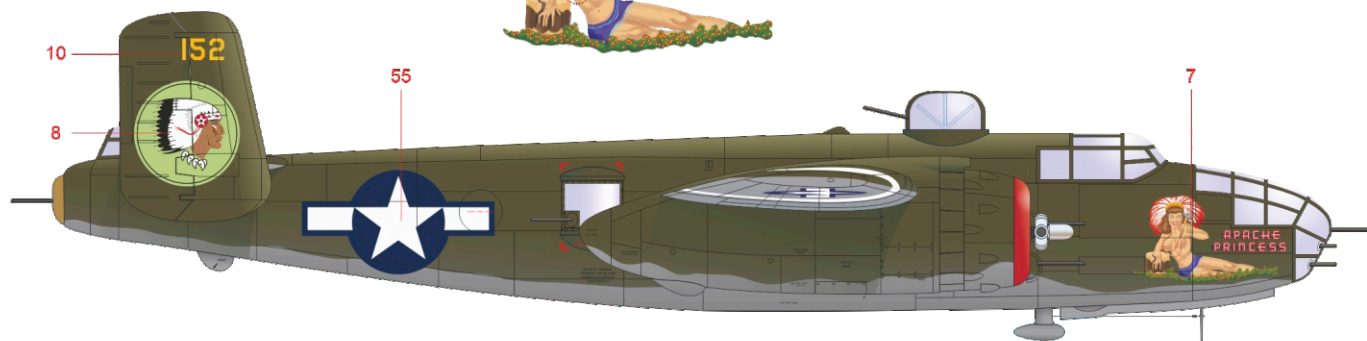
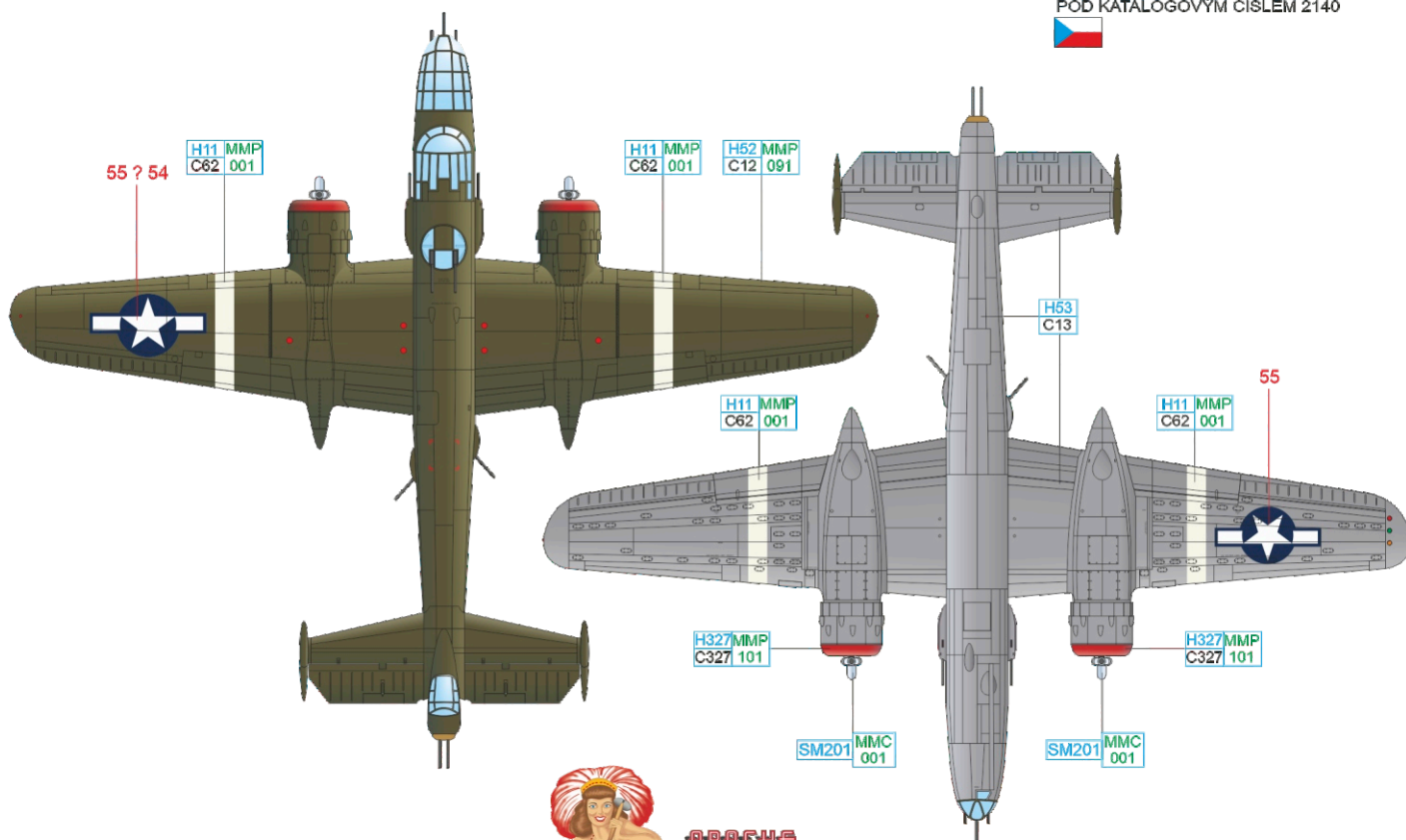

OLIVE DRAB	H52 MMP C12 091	RED	H327 MMP C327 101	NEUTRAL GRAY	H53 C13	WHITE	H11 MMP C62 001	SUPER FINE SILVER	SM201 MMC 001
------------	-----------------	-----	-------------------	--------------	---------	-------	-----------------	-------------------	---------------

D B-25J-1-NC, 43-27708, 488th BS, 340th BG, 12th AF, Corsica, France, 1945

The 340th Bomb Group was the "home" of Joseph Heller's famous Catch 22 novel as the author flew with the unit during the wartime as a bombardier. The group was activated on August 20, 1942 and arrived in the Mediterranean theater in March 1943. Assigned to the 9th AF and later to the 12th AF. On March 30, 1945, the 43-27708 ship named "Battlin' Betty" was flying the mission to bomb the Ora Rail Diversion Bridge in northern Italy. Overflying the Brenner Pass just some 400 ft over the hills, the ship was hit by flak. The shells damaged right engine and bomb bay doors and knocked out the electrical release system. Unable to drop the bombs and with one engine stopped the pilots just managed to maneuver the ship to the Venice area, where all the crew of 1/Lt Emmet W. Hughes bailed out and became POW. After captured by Italians they were handed over to Germans and forced to march 225 miles (!) to the Stalag Luft 7A in Moosburg, Germany. The "Battlin' Betty" and nice nose art of the woman with the javelin on the starboard side of the fuselage. Originally in natural metal finish the upper and side surfaces were overpainted in Olive Drab. The areas of the vertical fins with unit code and serial number were also left in bare metal, at least for some time. Joseph Heller flew several missions with this ship.

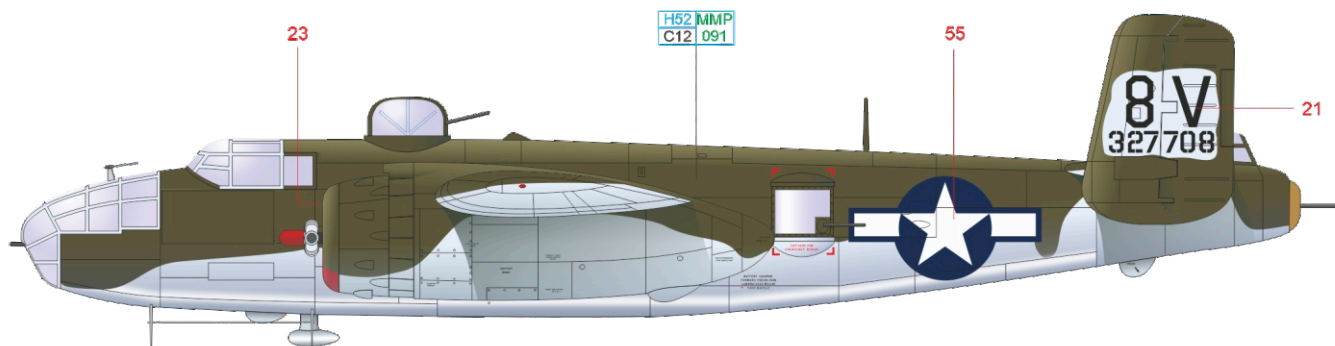

ČESKOU VERZI TEXTU NALEZNETE NA
www.eduard.com
 POD KATALOGOVÝM ČÍSLEM 2140

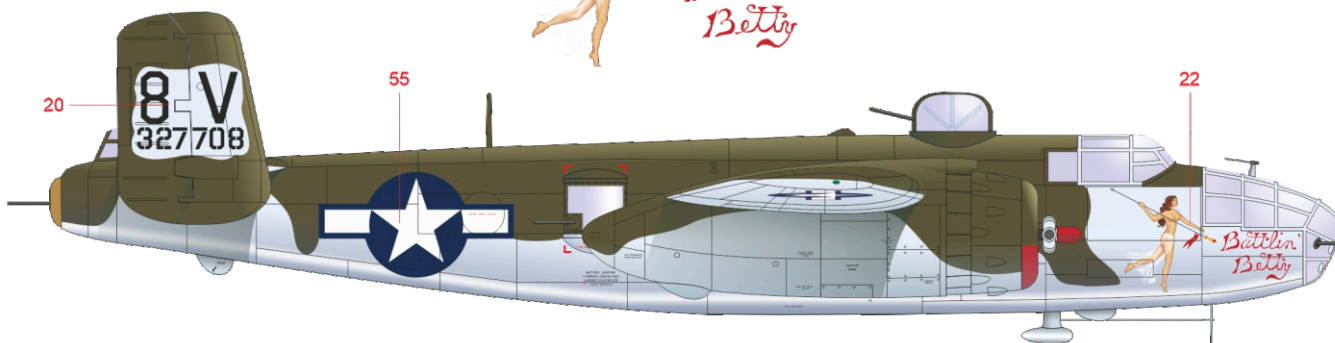
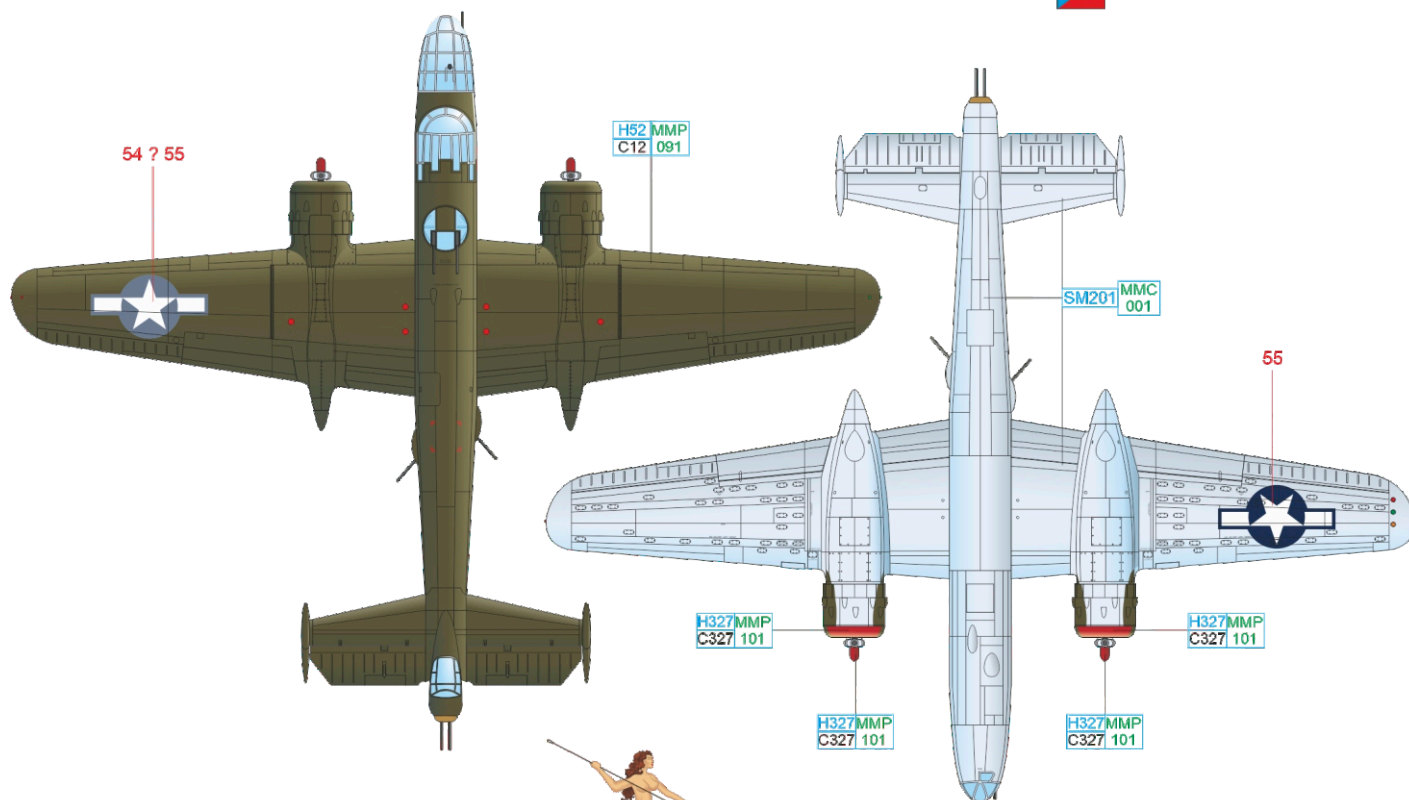

OLIVE DRAB	H52 MMP C12 091	RED	H327 MMP C327 101	SUPER FINE SILVER	SM201 MMC 001
------------	-----------------	-----	-------------------	-------------------	---------------

eduard

E B-25J-1-NC, 43-3890, 82nd BS, 12th BG, 10th AF, Fenny, India, December 1945

Constituted as 12th Bombardment Group (Light) on November 20, 1940, the unit was activated on January 15, 1941. The crews trained with B-18, B-23 and PT-17 aircraft and patrolled the west coast after the Japanese attack on Pearl Harbour. The group was redesignated as Medium in December 1941 and started flying the B-25s early in 1942. After spell with 9th AF in Mediterranean theater the group, nicknamed "Earthquakers", moved to India in February 1944 and was assigned to 10th AF. The 43-3890 was nicknamed "Milk Run" with paintings of five small, adorable bulldogs. Bulldog was a squadron's mascot, the term "Milk Run" was used for easy, low-risk missions and several other aircraft were named similarly. The painting was a job of Capt. Norman L. Harms, one of the second pilots of the unit. The "Milk Run" ship was painted in standard camouflage of Olive Drab upper and side surfaces with Neutral Gray from bottom.

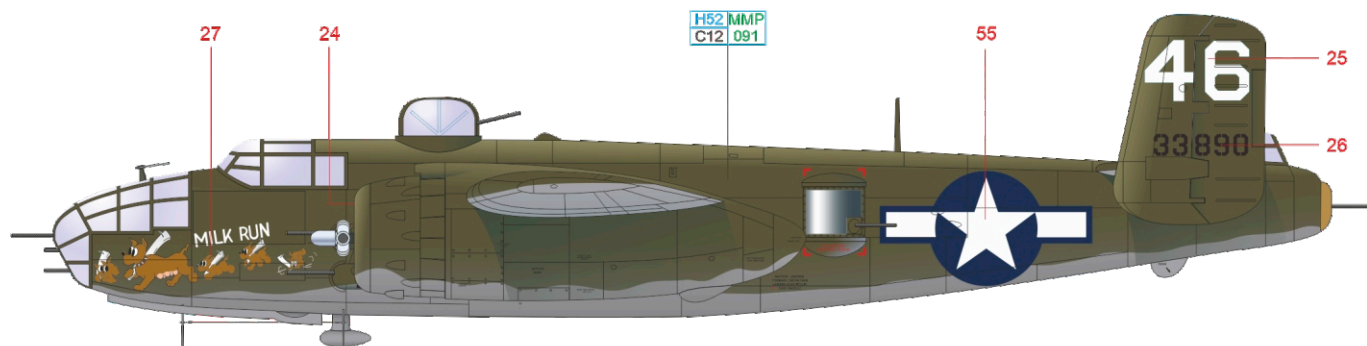

ČESKOU VERZI TEXTU NALEZNETE NA
www.eduard.com
 POD KATALOGOVÝM ČÍSLEM 2140

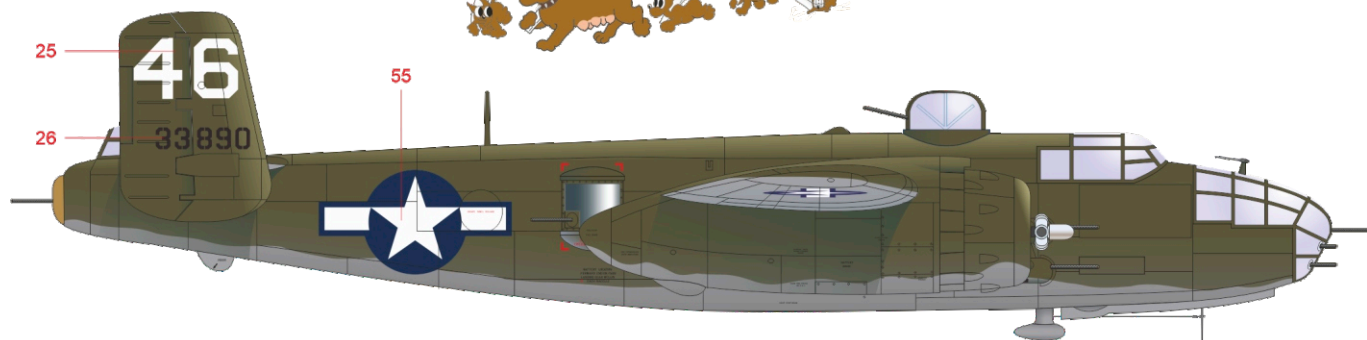
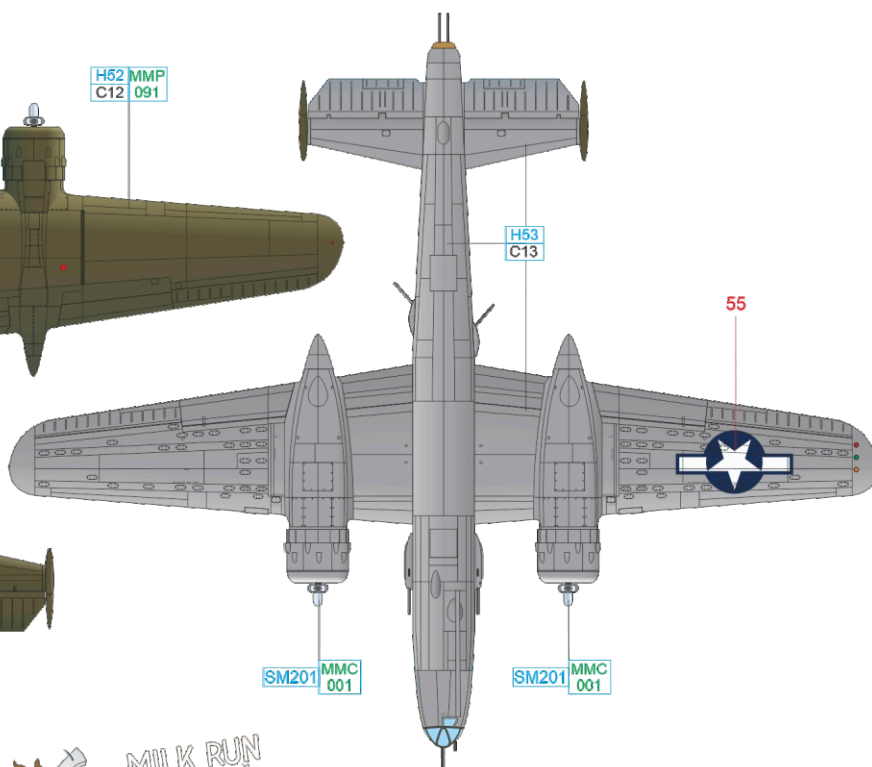
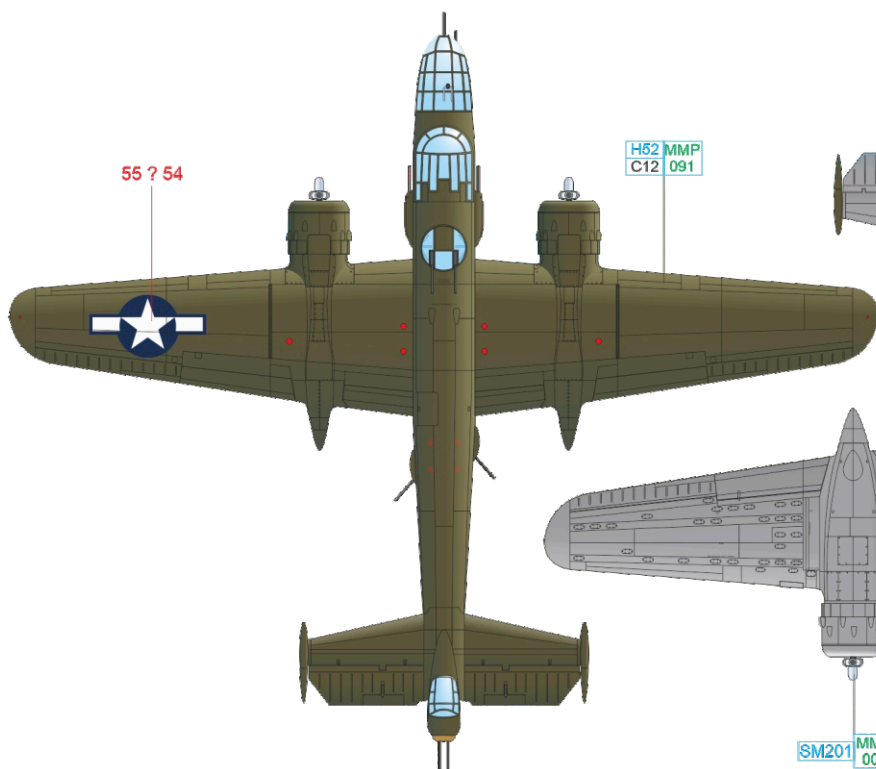

OLIVE DRAB H52 MMP C12 091 NEUTRAL GRAY H53 C13 SUPER FINE SILVER SM201 MMC 001

eduard

F B-25J-10-NC, 43-36020, 501st BS, 345th BG, 5th AF, Tacloban, Philippines, April 1945

One of the paintings of Sgt. George M. Blackwell, who decorated several other aircraft of 345th Bomb Group, was the "Reina del Pacifico" (Queen of the Pacific), the B-25J-10-NC of serial number 43-36020. The large nose art was one of the most stunning paintings on the B-25s. Blackwell started this painting at the end of November, finishing it at the beginning of December 1944. The ship was shot down during the mission over Saigon on April 28, 1945, when 2/Lt. M. R. Esty and 2/Lt M. E. Miller were in the pilot seats. All five crewmembers were killed in the subsequent crash. The ship had the paint scheme of the Olive Drab on upper and side surfaces with Neutral Gray undersides and sported the earlier variant of the Indian emblem on the vertical fins. It is not known whether or not the newer, simplified version of the Air Apaches emblem was painted on the vertical fins prior to the crash of the Reina del Pacifico.

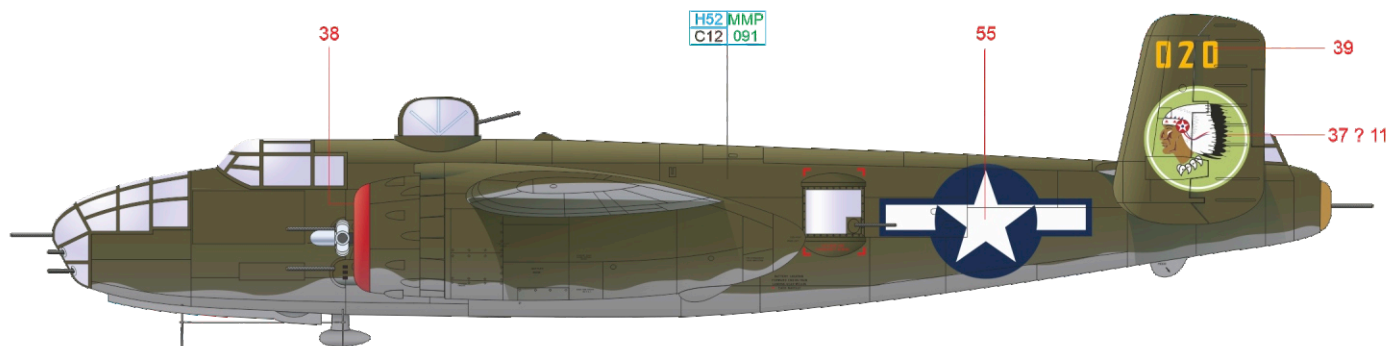

ČESKOU VERZI TEXTU NALEZNETE NA
www.eduard.com
 POD KATALOGOVÝM ČÍSLEM 2140

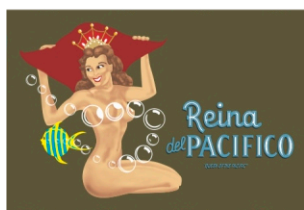
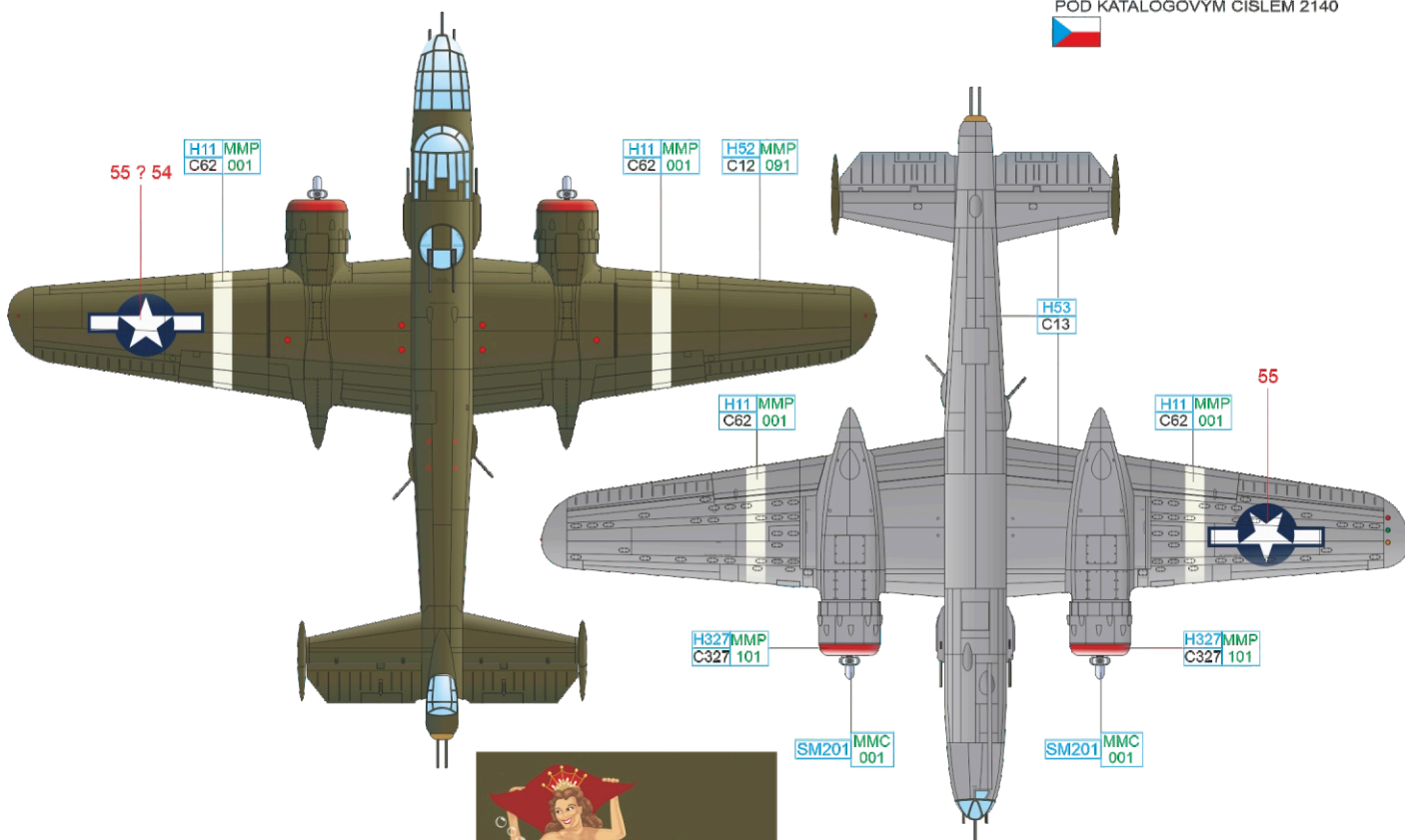

OLIVE DRAB	H52 MMP C12 091	RED	H327 MMP C327 101	NEUTRAL GRAY	H53 C13	WHITE	H11 MMP C62 001	SUPER FINE SILVER	SM201 MMC 001
------------	-----------------	-----	-------------------	--------------	---------	-------	-----------------	-------------------	---------------

The 43-27559 Mitchell nicknamed "She's Engaged" was veteran of more than 100 missions. The ship was left in bare metal and sported painting of beautiful sitting lady in summer dress painted according to one of paints of famous pre-war artist Alberto Vargas (as were many other nose arts). The original Vargas's painting was later published in the Esquire calendar of January 1946. The ship was assigned to Sgt. Elton T. Larsen as a crew chief and to Lt. John W. Allen as a pilot. The identification band on the vertical fins consisted of the upper yellow one (310th BG colour) and lower blue one (color of the 380th BS). As with other bare metal ships in 310th BG, the bands were separated by black lines. The engine nacelles had Olive Drab upper insides; the same color was painted in front of the windshield (anti-glare panel). The Olive Drab was also used as a background for the bomb marks.

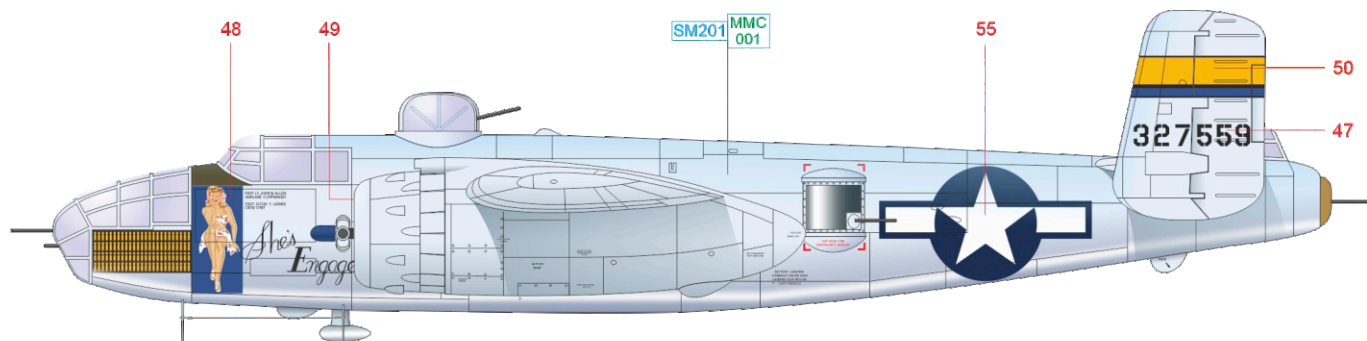

ČESKOU VERZI TEXTU NALEZNETE NA
www.eduard.com
 POD KATALOGOVÝM ČÍSLEM 2140

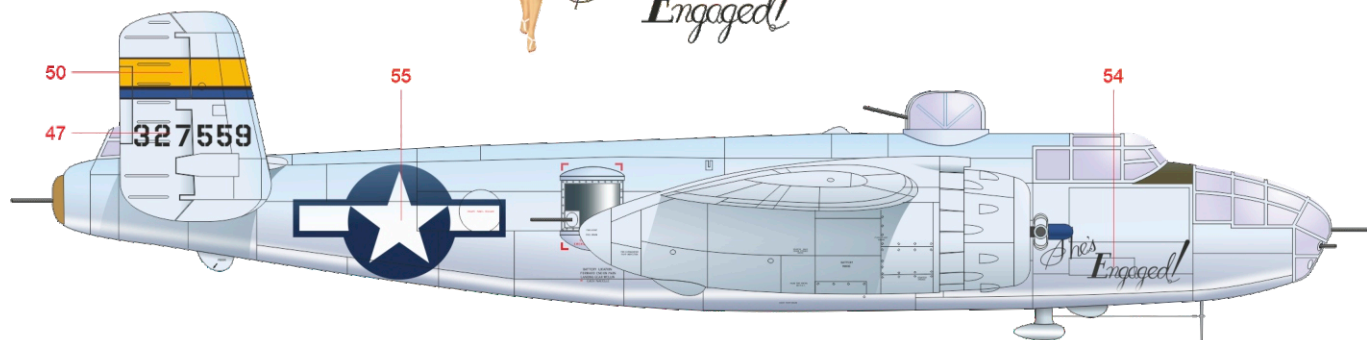
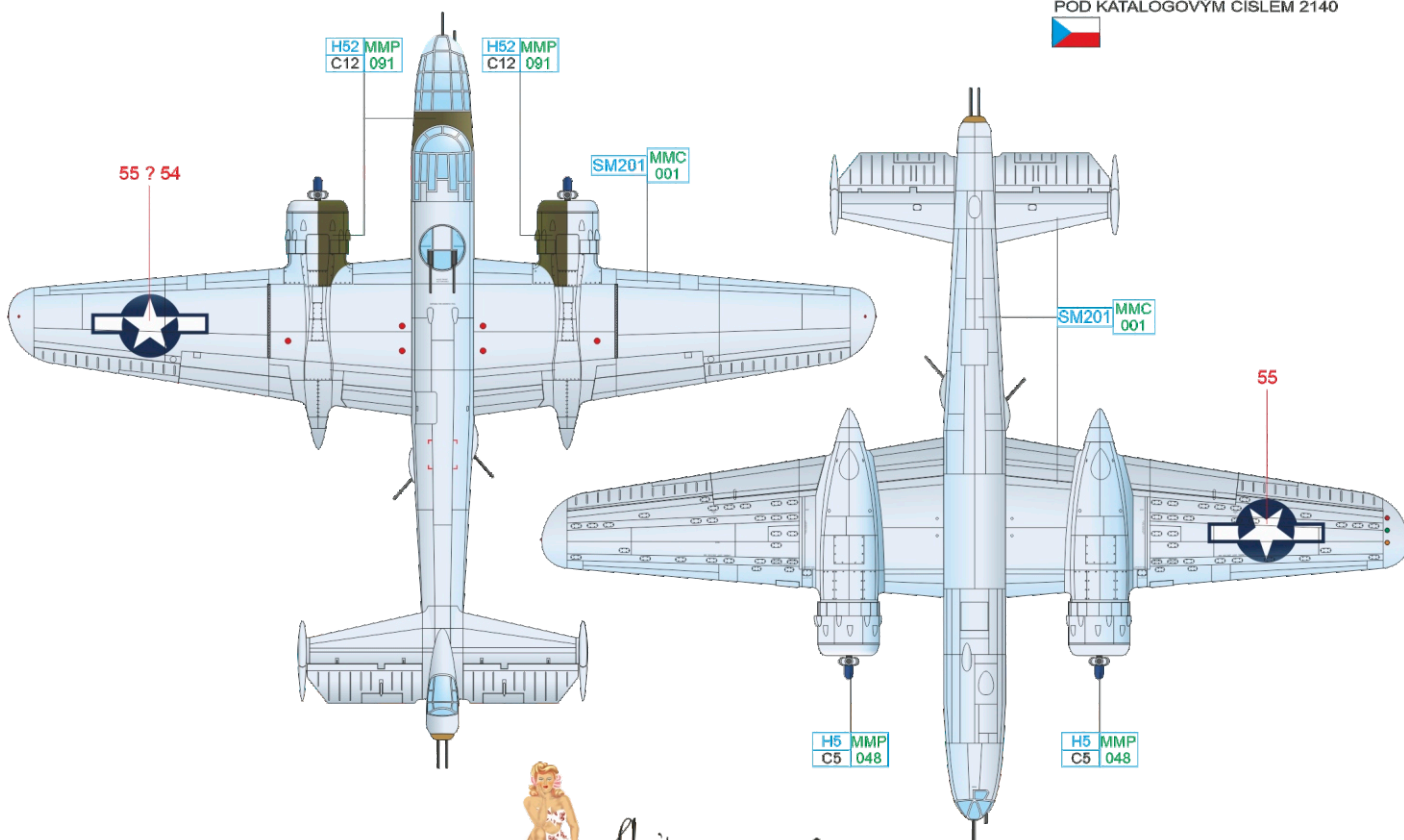

H B-25J-11, 43-36001, 75th BS, 42nd BG, 13th AF, Philippines, 1945

The 42nd Bombardment Group (Medium) was activated on January 15, 1941, from the 7th BG (Heavy) at Fort Douglas, Utah. It was later nicknamed "Crusaders". The 43-36001 ship was nicknamed "Nasty Nancy" and got painting of beautiful and scanty suited girl riding a torpedo. On April 10, 1945, the "Nasty Nancy" was assigned rather specific job. During the mission No. 48 of 42nd BG she was to fly a route over the city of Saigon in broad daylight at the height of 10,000 ft as a decoy for Japanese fighters. The plan was to lure the enemy into a trap as there were P-38s waiting for them above and ready to attack after the code sentence "Little friends, come down and play" was sent over the radio by the crew of Lt. Joseph Wright. Apart of the kills by P-38s, four Japanese fighters were shot down by gunners of the "Nasty Nancy". The rear gunner, Sgt. William Outlaw even used his .45 caliber pistol to shoot at the enemy fighters after his machine guns jammed. The ship had its nose art painted on the starboard side of the front fuselage, the color scheme was usual in Olive Drab and Neutral Gray with yellow wingtips and top of the vertical stabilizer and rudder. The groups' badge was also painted on the vertical fins.

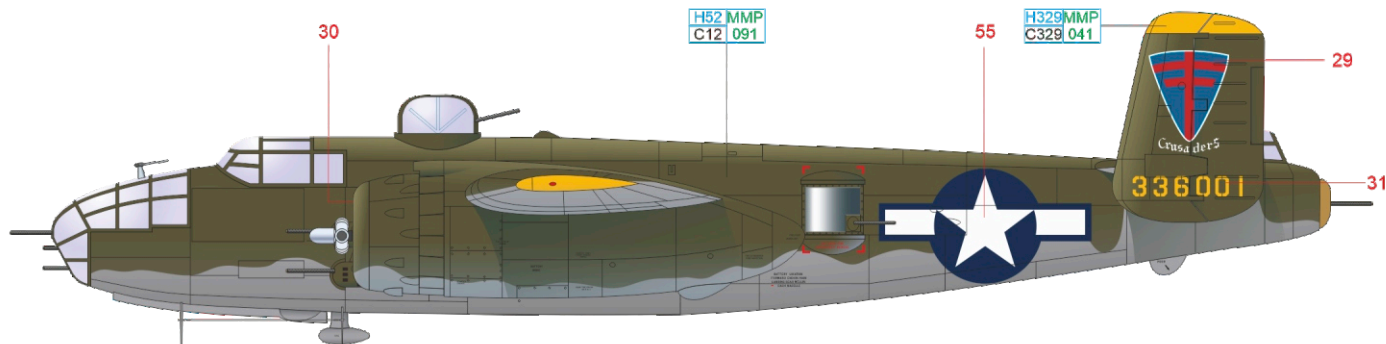

ČESKOU VERZI TEXTU NALEZNETE NA
www.eduard.com
 POD KATALOGOVÝM ČÍSLEM 2140

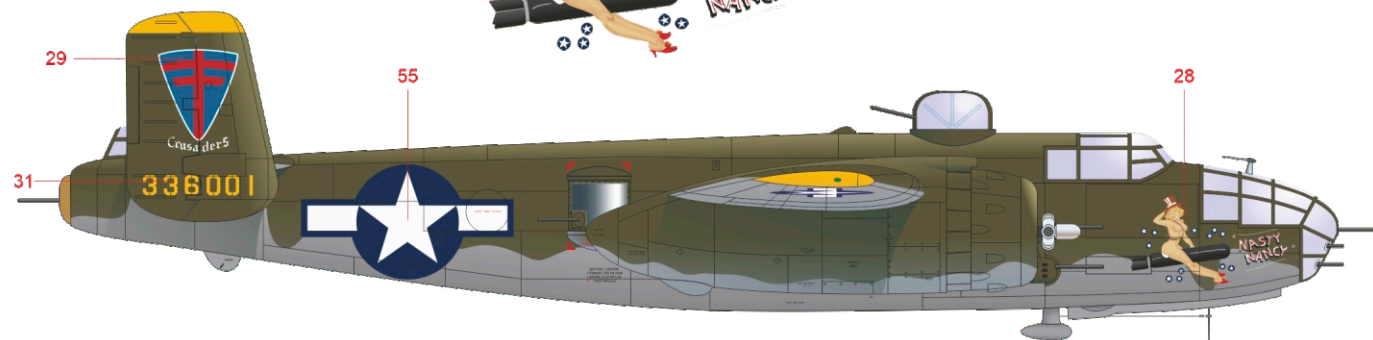
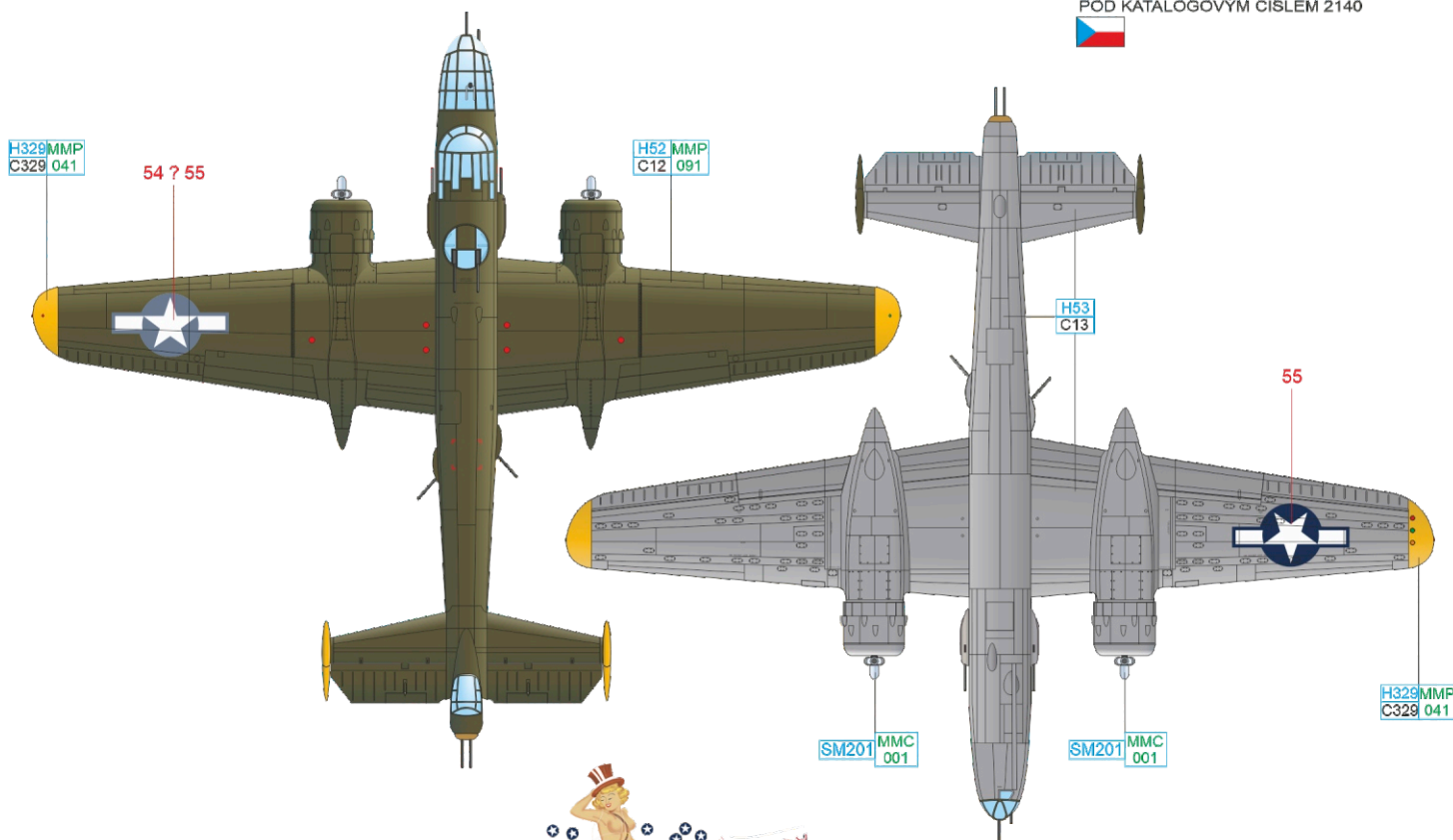

OLIVE DRAB	H52 MMP C12 091	ORANGE YELLOW	H329 MMP C329 041	NEUTRAL GRAY	H53 C13	SUPER FINE SILVER	SM201 MMC 001
------------	-----------------	---------------	-------------------	--------------	---------	-------------------	---------------

eduard

B-25J-5, 43-27952, 823rd BS, 38th BG, 5th AF, Morotai, Indonesia, November 1944

The 38th Bombardment Group (Medium) was constituted on November 20, 1940, and activated on January 15, 1941, at Langley Army Air Base, Virginia. The initial personnel were transferred from the 22nd Bombardment Group. The 38th BG consisted of four squadrons, but two of them were assigned to the 42nd BG after the Battle of Midway. The 823rd Bomb Squadron was constituted and assigned to the 38th BG in New Guinea on April 20, 1943, as well as the 822nd BS, the two bringing the 38th BG to the full strength of four squadrons again. The 823rd BS adopted the name „Terrible Tigers“ and started to decorate their aircraft correspondingly. It was also the case of the No. 952 ship, which was one of few with glass cockpit left, as many B-25Js of the 38th BG were either original strafers with solid nose or modified with the glass nose painted over. The “952” was assigned to Lt. John W. Lupardus as a pilot. The tiger’s head was partly painted over the glass part of the nose of the ship, the camo colors were standard Olive Drab and Neutral Gray. The lower part of the fin was either green or blue. The blue was assigned to the squadron, but the green was also used on some aircraft as it did not intervene with markings of other squadrons (the 405th BS used also green color, but on the upper part of the fins).

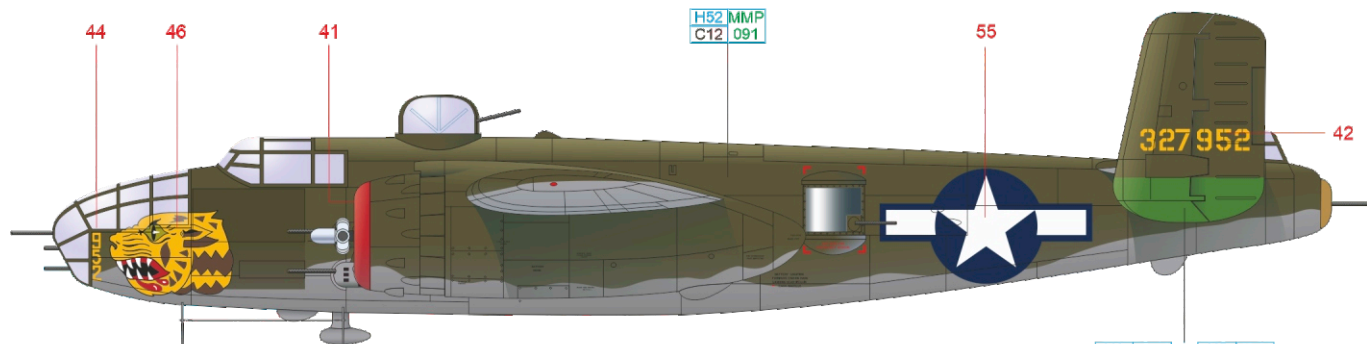

H52 MMP C12 091
H6 MMP C6 004 ? H5 MMP C5 048

ČESKOU VERZI TEXTU NALEZNETE NA
www.eduard.com
POD KATALOGOVÝM ČÍSLEM 2140

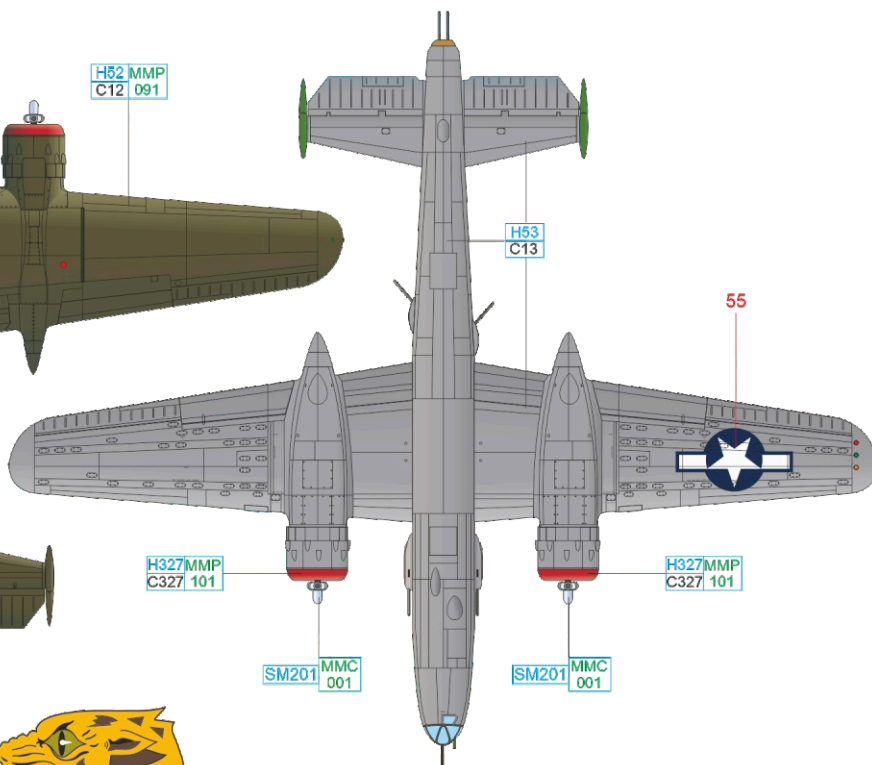
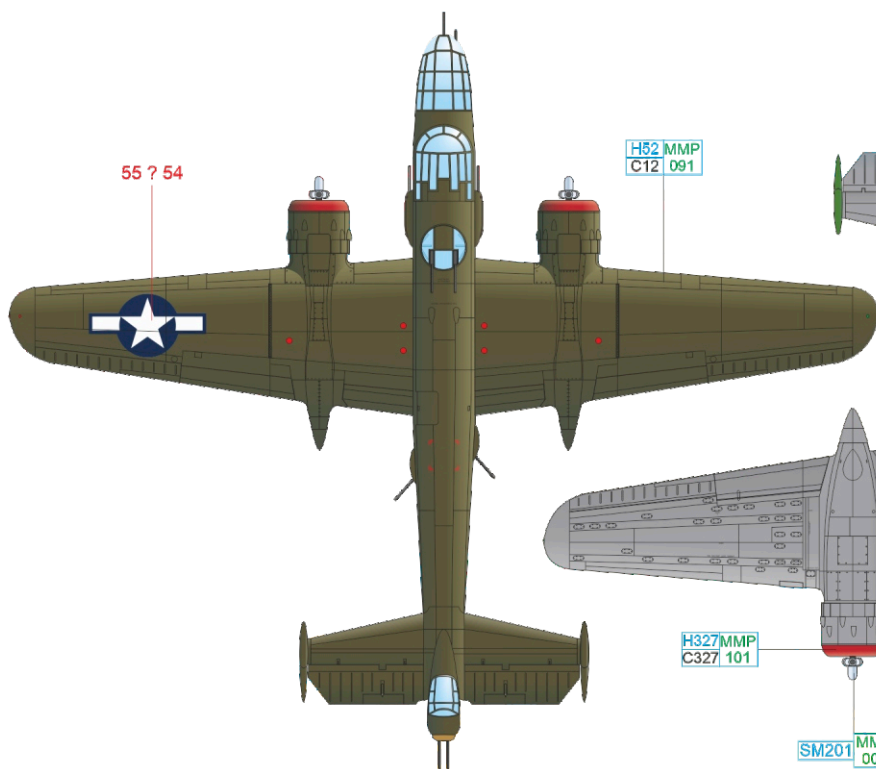

BLUE	H5 MMP C5 048	RED	H327 MMP C327 101	GREEN	H6 MMP C6 004	NEUTRAL GRAY	H53 C13	SUPER FINE SILVER	SM201 MMC 001
------	---------------	-----	-------------------	-------	---------------	--------------	---------	-------------------	---------------

J B-25J-1-NC, 43-27540, 487th BS, 340th BG, 12th AF, Alesani, Corsica, France, April 1945

One of the most famous squadrons within the 37th Bombardment Wing at the end of the war were the Dogfaces, the 487th BS. It was decided one of the squadrons of the 37th Bomb Wing should honor the bravery and misery of the soldiers on the ground, and it was decided by the personnel to do it by means of paintings of the characters of the famous cartoons of Bill Mauldin. Mauldin himself sketched twelve characters based on his often-featured infantrymen Willie and Joe. The 43-27540 ship was nicknamed "Watch Copier" according to the painting of the soldier checking his watches. Other known ships decorated in the honor of the infantrymen were for example "Uncle Willie", "Supper Unit Ration K" or "G. I. Joe". These impressive paintings were made by Sgt. Greg Moore and Sgt. Durley Bratton with assist of sergeant Gavette during January of 1945. The ship with code 7E was flown by several pilots most frequently by Lieutenants C. Cook and B. O. Lyons. The "Watch Copier" ship was painted in Olive Drab/Neutral Gray finish, supplemented with blue spinner and front of the engine nacelles. At the end of the war, she had 142 missions flown.

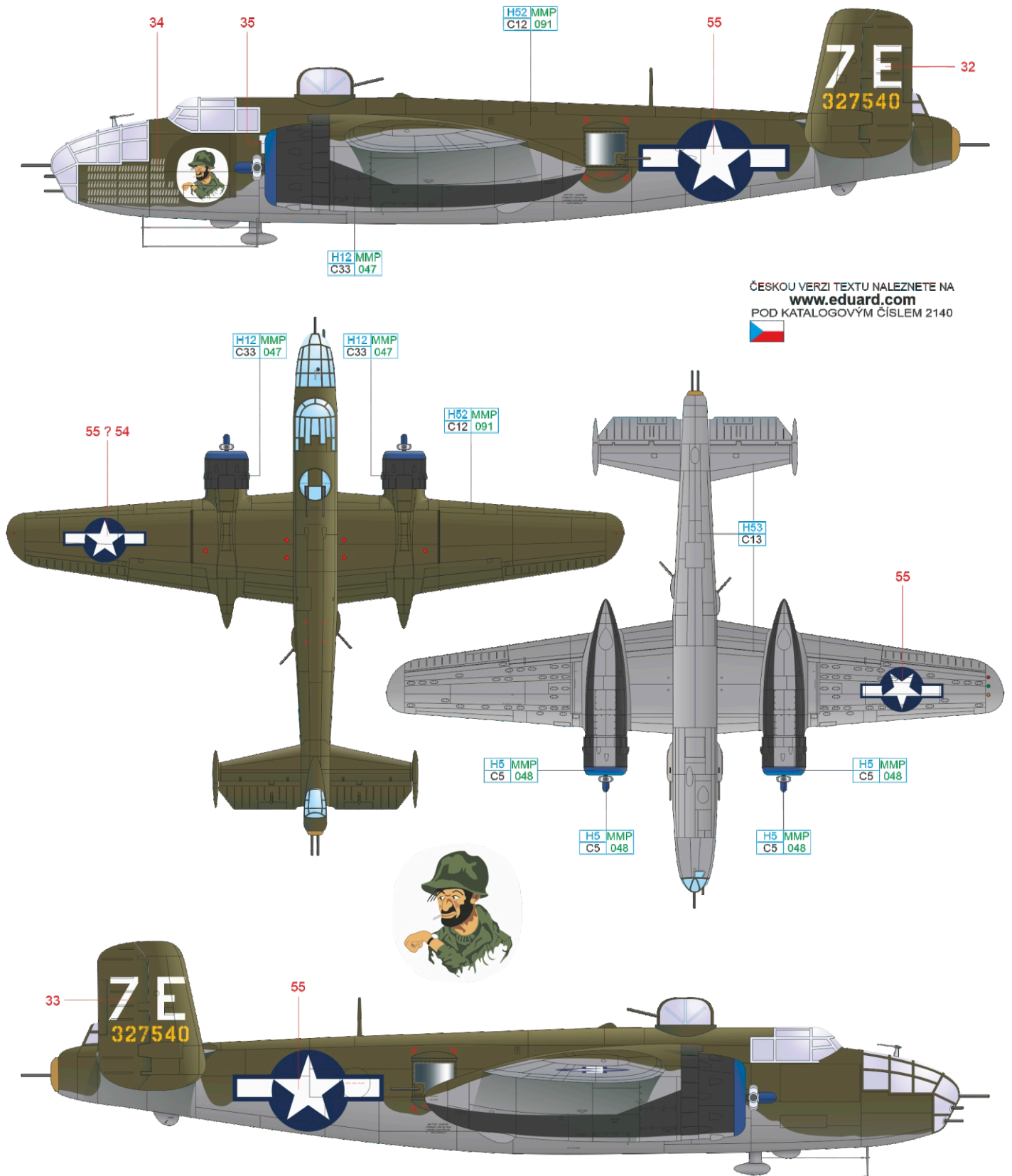

ČESKOU VERZI TEXTU NALEZNETE NA
www.eduard.com
 POD KATALOGOVÝM ČÍSLEM 2140



OLIVE DRAB	H52 MMP C12 091	LIGHT BLUE	H5 MMP C5 048	NEUTRAL GRAY	H53 C13	BLACK	H12 MMP C33 047
------------	-----------------	------------	---------------	--------------	---------	-------	-----------------

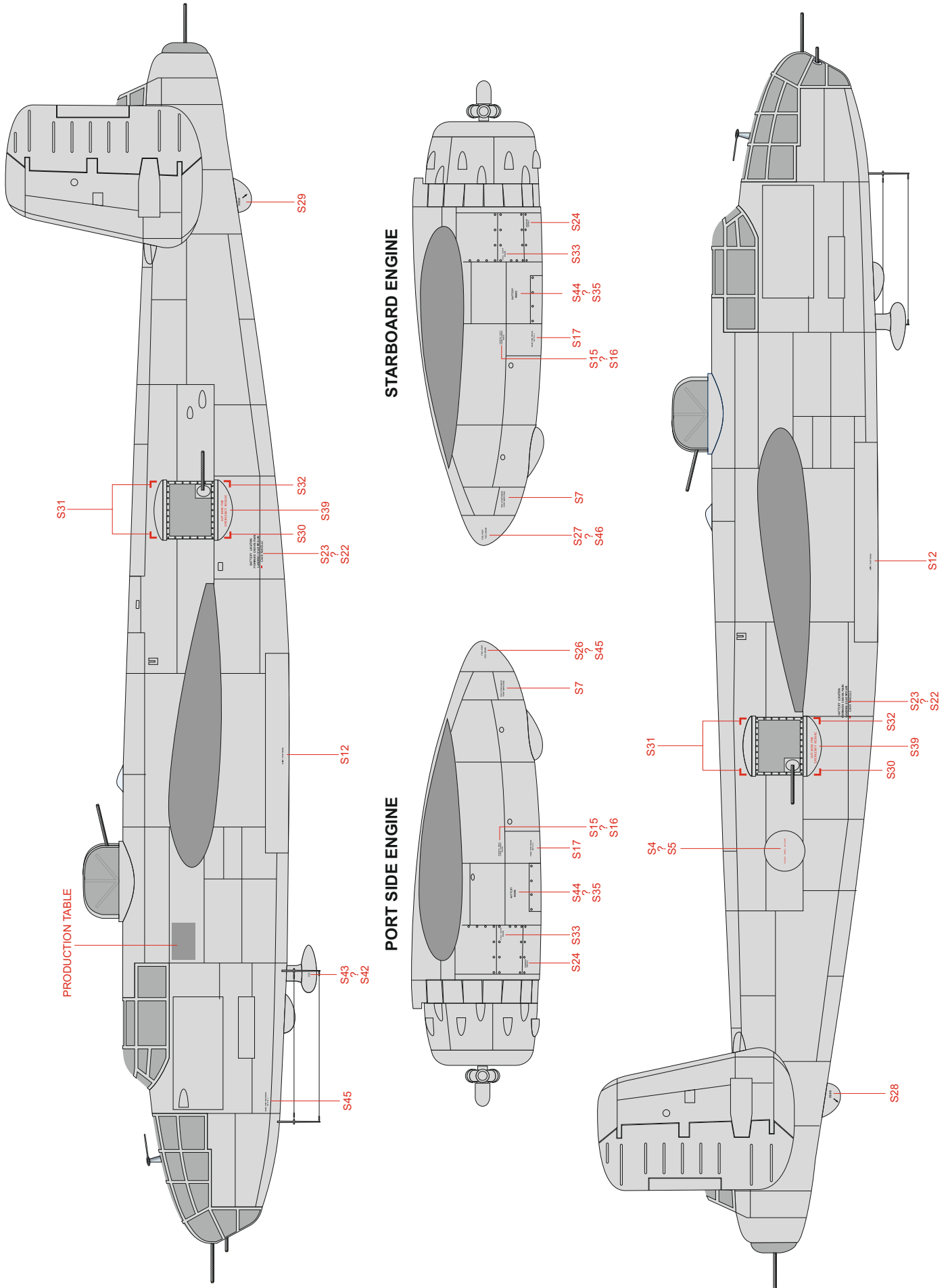

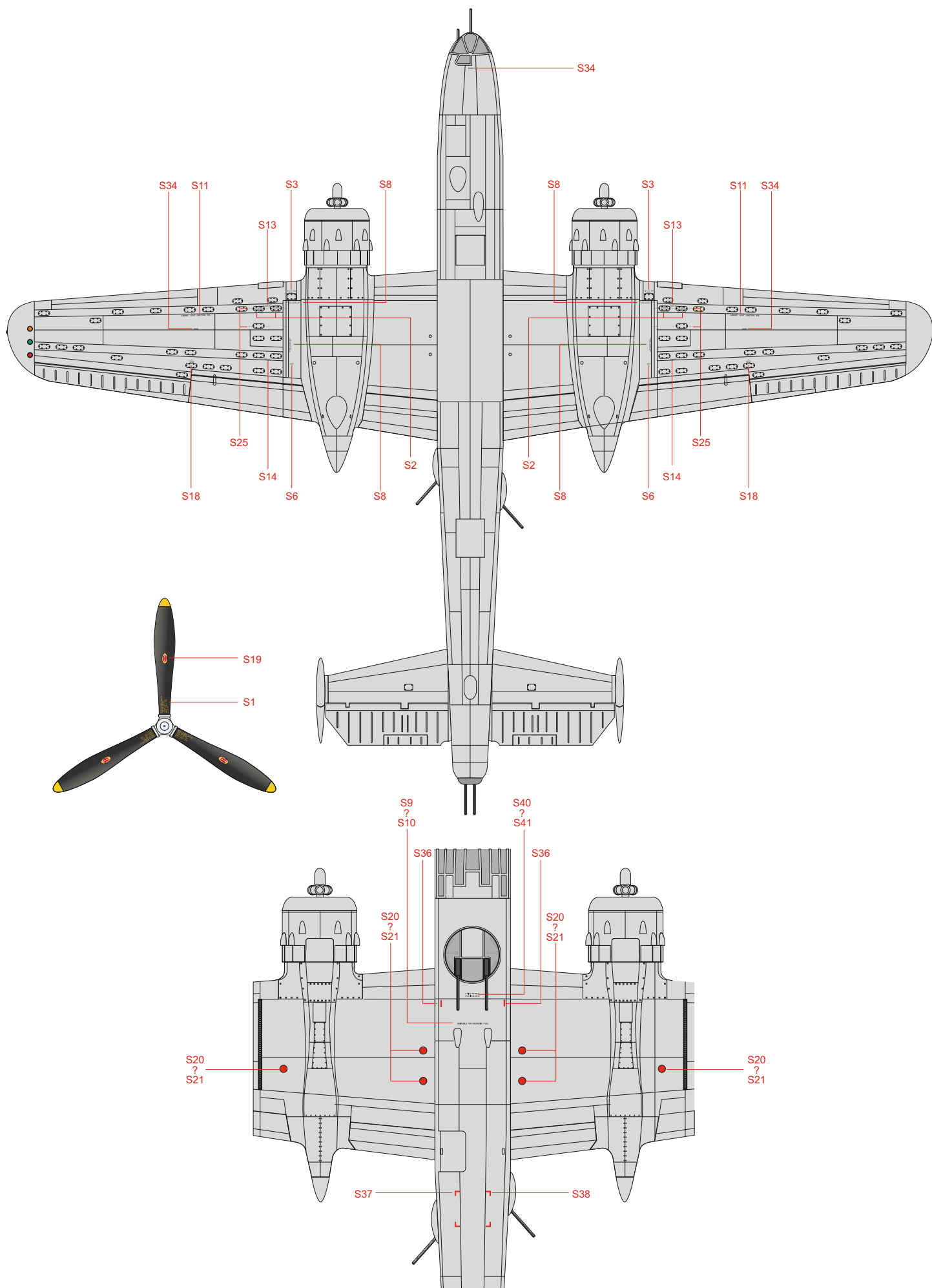

Eduard goodies for

ANGEL OF MERCY 1/72

- 72424 B-25J exterior (PE-Set)
- 72425 B-25J bomb bay (PE-Set)
- 73007 Ammunition Belts US Cal.0.50 (PE-Set)
- 672038 US 250lb bombs (Brassin)
- 672039 US 500lb bombs (Brassin)
- 672092 M-2 Browning guns (Brassin)
- 672244 US 1000lb bombs (Brassin)

Cat. No. 672038



Cat. No. 672244



Cat. No. 672039

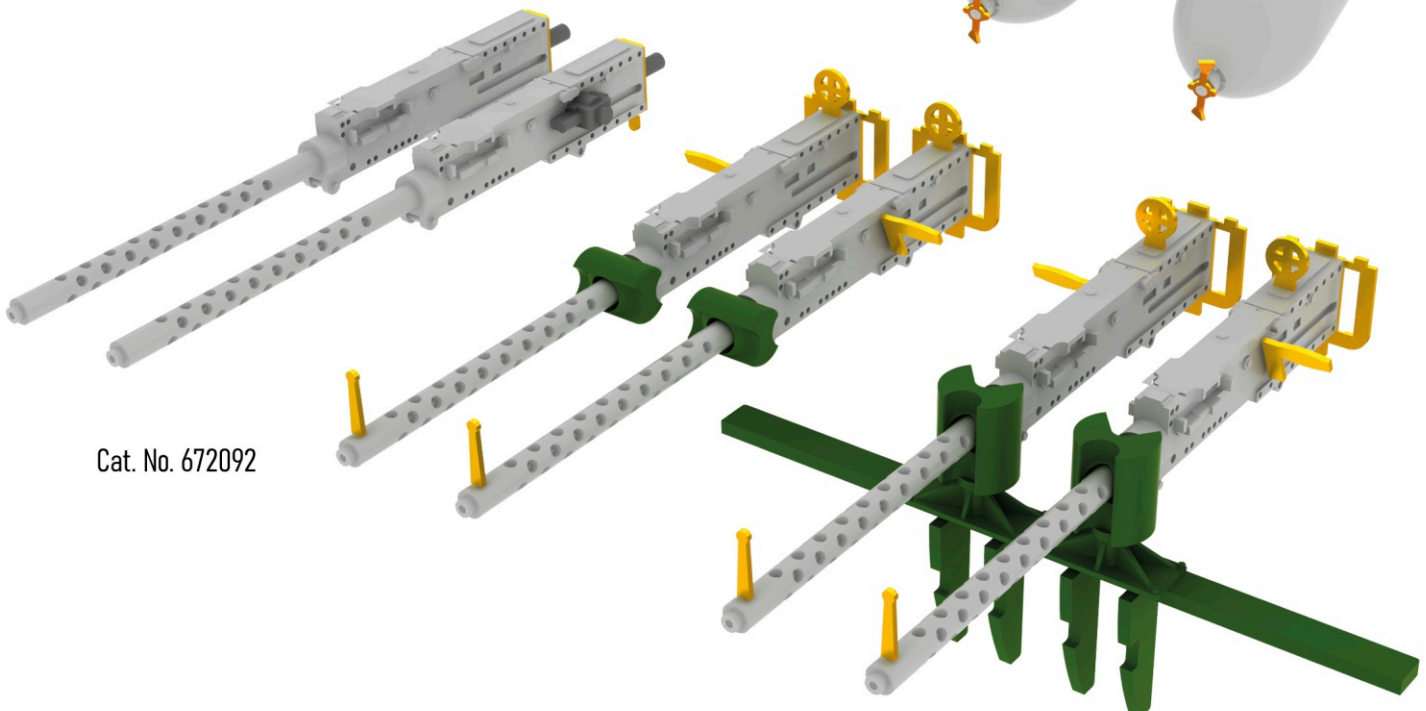

Cat. No. 672092