

SUPER44

COLORS BARVY FARBEN PEINTURE 色

GSI Creos (GUNZE)		MISSION MODELS	
AQUEOUS	Mr.COLOR	PAINTS	
[H4]	C4	[MMP-007]	YELLOW
[H11]	C62	[MMP-001]	FLAT WHITE
[H12]	C33	[MMP-047]	FLAT BLACK
[H13]	C3	[MMP-003]	FLAT RED
[H33]	C81		RUSSET
[H71]	C21	[MMP-076]	MIDDLE STONE
[H72]	C369	[MMP-078]	DARK EARTH
[H74]	C368	[MMP-080]	SKY
[H77]	C137	[MMP-040]	TIRE BLACK
[H327]	C327	[MMP-101]	RED

GSI Creos (GUNZE)		MISSION MODELS	
AQUEOUS	Mr.COLOR	PAINTS	
[H330]	C361	[MMP-077]	DARK GREEN
[H335]	C363	[MMP-094]	MEDIUM SEAGRAY
	C362	[MMP-093]	OCEAN GRAY
	C364	[MMP-079]	AIRCRAFT GRAY-GREEN
	C370		AZURE BLUE
Mr.METAL COLOR		METALLICS	
[MC218]		[MMM-093]	ALUMINIUM
Mr.COLOR SUPER METALLIC		METALLICS	
[SM201]		[MMC-001]	SUPER FINE SILVER

PLASTIKOVÁ STAVEBNICE 
 FOTOLEPTANÉ DÍLY, EXPRESS MASK,
 NEOBSAHUJE BARVY A LEPIDLO
 VYROBENO V ČESKÉ REPUBLICĚ

POZOR! OBSAHUJE DROBNÉ A OSTRÉ DÍLY
VÝROBEK NENÍ HRAČKOU

SCALE PLASTIC KIT 
 PE PARTS, MASK,
 PAINT AND GLUE NOT INCLUDED
 MADE IN CZECH REPUBLIC

CONTAINS SMALL AND SHARP PARTS.
COLLECTORS ITEM · NOT A TOY

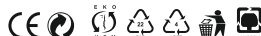

Spitfire Mk.IXc late 1/144

Cat.No. 4433



MK984, flown by S/Ldr Witold Retinger, No. 308 Squadron,
 B-61 Sint Denijs Westrem airfield, Belgium, November 1944



flown by Maj. Garth Jared, CO of 309th FS, 31st FG, USAAF,
 Pomigliano / Castel Volturno AB, Italy, late 1943/early 1944



MJ558, W/O A. Mrtvý, No. 313 Squadron, 1944

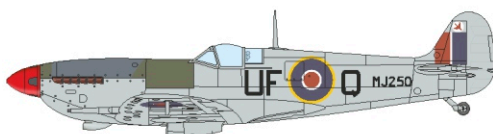

MJ250, No. 601 Squadron, Italy, Summer 1944

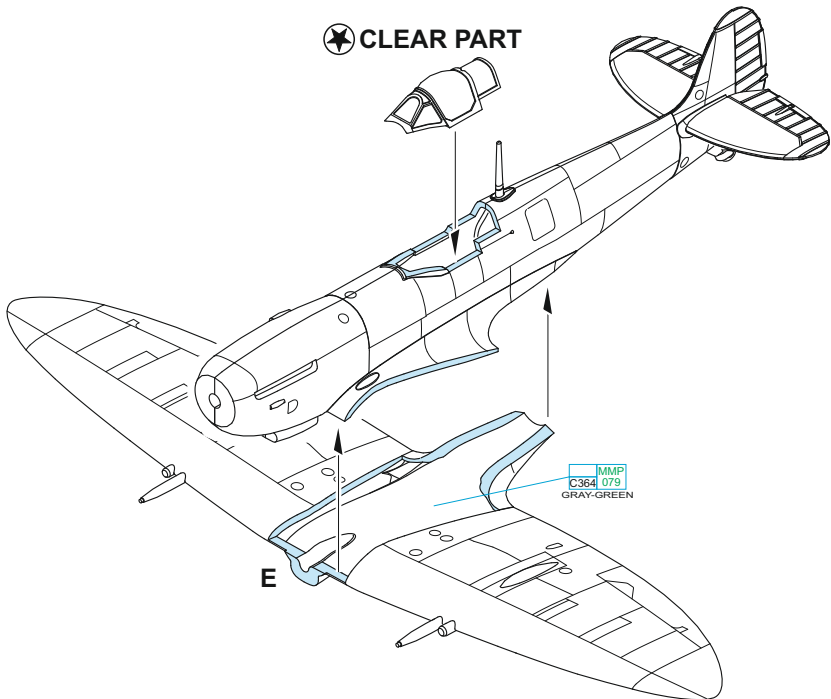
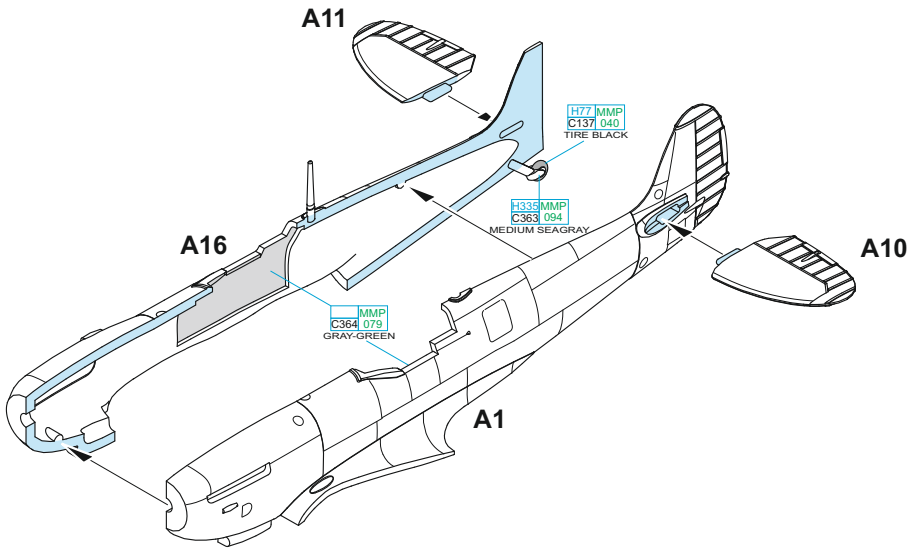

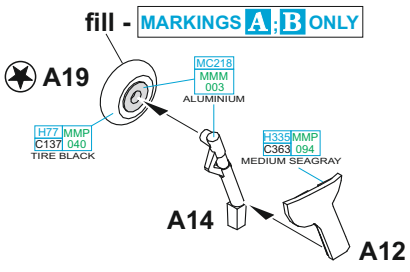
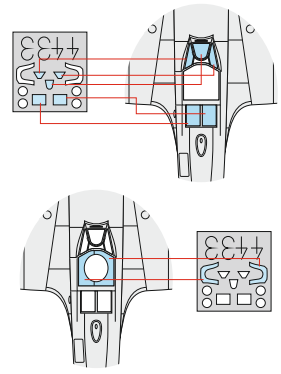
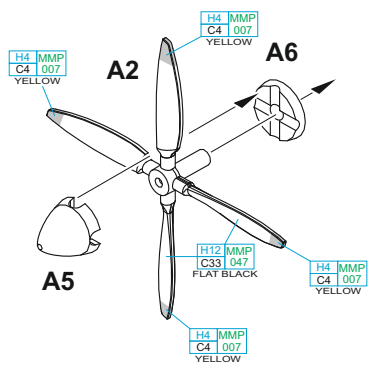
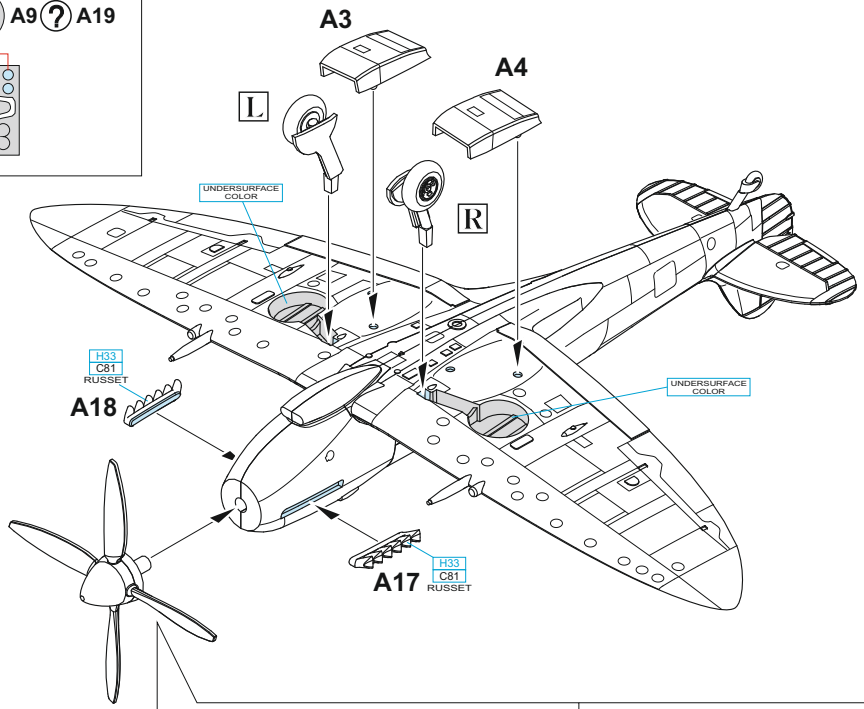
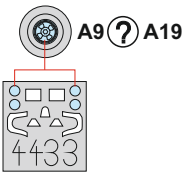
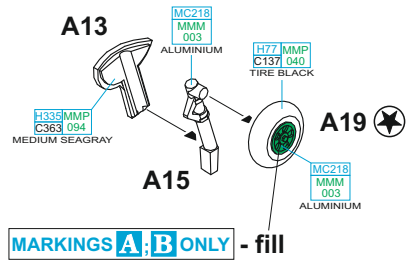
L**R**

A MK984, flown by S/Ldr Witold Retinger, No. 308 Squadron, B-61 Sint Denijs Westrem airfield, Belgium, November 1944

Witold Retinger was born on April 4th, 1918, in Wiener Neustadt. After graduation from high school he enlisted in the Aviation School in Deblin graduating in 1939. After the fighting in Poland was over he left for France from which he fled to Great Britain. There, after the necessary training, he was assigned to No. 308 Squadron. Later he served with No. 303 and No. 309 Squadrons. On March 21st, 1944 he was made commander of No. 308 Squadron with which he participated in the Normandy Invasion followed by combat over the Old Continent front. On November 16th, 1944, having completed his tour of duty, S/Ldr Retinger was sent for the period of rest. After the war he left military. In the end of 40s and most of 50s he worked for the airlines in South America. From 1957 till 1981 he worked for Pan American Airways. He passed away on June 22nd, 1982 in New York. Black and white stripes, so-called D-day stripes, were added to the camouflage of this machine at dawn of the Normady Invasion. In September 1944 the stripes were overpainted in standard camouflage colors on the wings and fuselage upper surfaces leaving them partially visible on the sides and bottom of the fuselage. Lala was the name of Retinger's girlfriend.

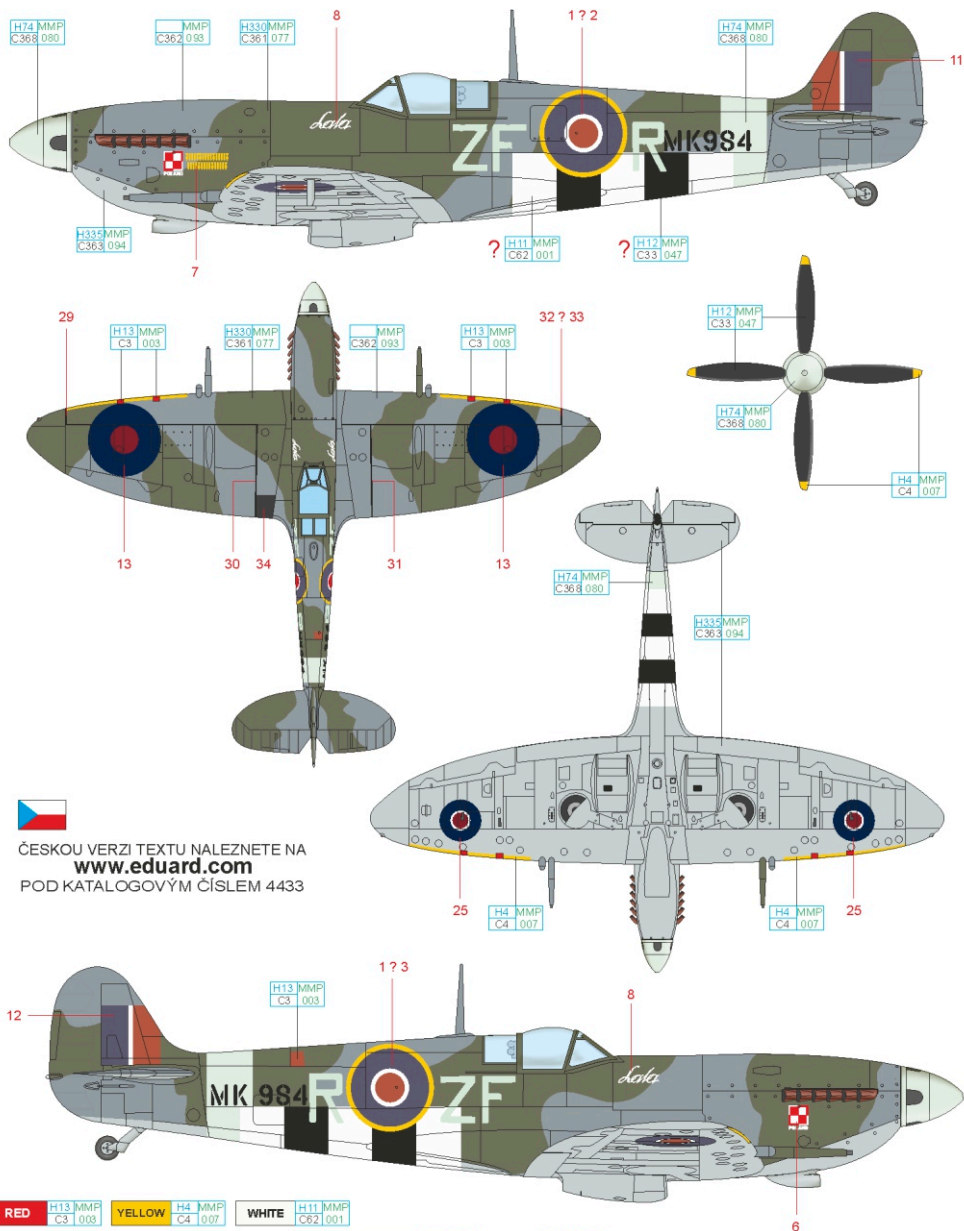

ČESKOU VERZI TEXTU NALEZNETE NA
www.eduard.com
 POD KATALOGOVÝM ČÍSLEM 4433

RED	H13 MMP C3 003	YELLOW	H4 MMP C4 007	WHITE	H11 MMP C62 001
SKY	H74 MMP C368 080	MEDIUM SEA GRAY	H335 MMP C363 094	OCEAN GRAY	MMP C362 093
		DARK GREEN	H330 MMP C361 077	BLACK	H12 MMP C33 047

B flown by Maj. Garth Jared, CO of 309th FS, 31st FG, USAAF, Pomigliano / Castel Volturno AB, Italy, late 1943/early 1944

Major Garth Jared served as the CO of 309th Fighter Squadron from November 9th, 1943, till his death on April 18th, 1944. He lost his life at the controls of a P-51B Mustang near Trieste, Italy. Jared flew this Spitfire as a personal mount in late 1943 and early 1944. The desert camouflage consists of Mid Stone and Dark Earth on upsides and Azure Blue on the undersides. British roundels on the wings were overpainted with a fresh camouflage color. Jared, being the squadron leader, had the right to use his initials as the aircraft code. Two swastikas under the canopy symbolize Jared's two confirmed kills (Me 109) achieved on December 7th, 1943. The third confirmed kill was an Fw 190 downed on February 16th, 1944. Note the unit badge on the nose.

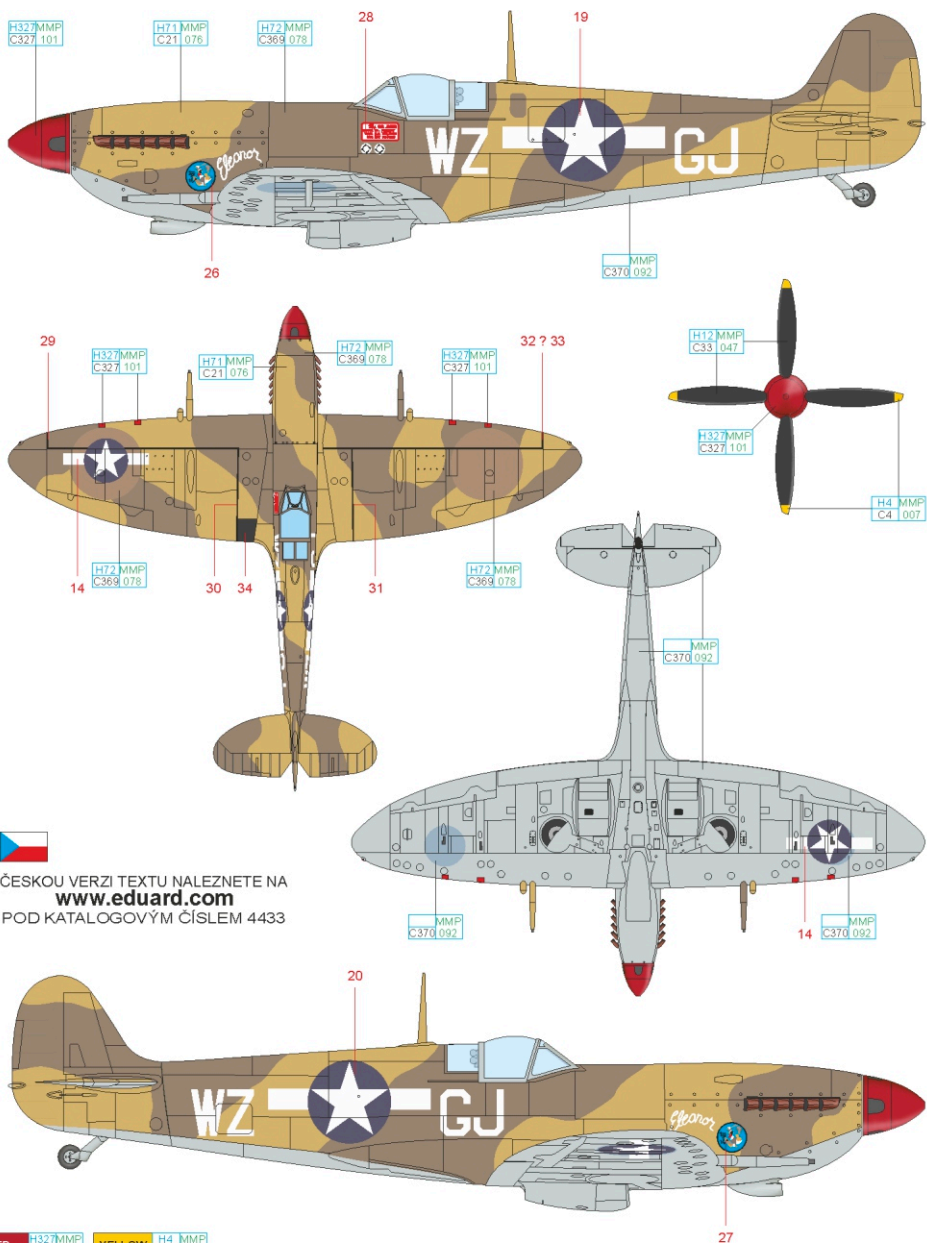

ČESKOU VERZI TEXTU NALEZNETE NA
www.eduard.com
 POD KATALOGOVÝM ČÍSLEM 4433

RED	H327 MMP C327 101	YELLOW	H4 MMP C4 007
AZURE BLUE	MMP C370 092	MIDDLE STONE	H71 MMP C21 076
		DARK EARTH	H72 MMP C369 078
		BLACK	H12 MMP C33 047

C MJ558, W/O A. Mrtvý, No. 313 Squadron, 1944

Arnost Mrtvý started his combat career in RAF in April 1941 with No. 257 Squadron flying Hurricanes at that time. His aviator's career continued flying Spitfires, first with No. 65 Squadron and since August 1941 with Czechoslovak No. 313 Squadron. After the period of rest in February 1944, he returned to No. 313 Squadron. On April 19th, 1944, he met his fate during the sortie escorting 9thAF American Marauders attacking Mallines when he was shot down by Hptm. Wilhelm Neu. His struck, no longer controlled Spitfire, crashed at Herentals nearby Antwerp. The pilot was able to bail out however his parachute was shot to pieces by flak. His victor met his own fate three days later. Hptm. Neu was shot down and killed by American fighters over the Eifel mountain range.

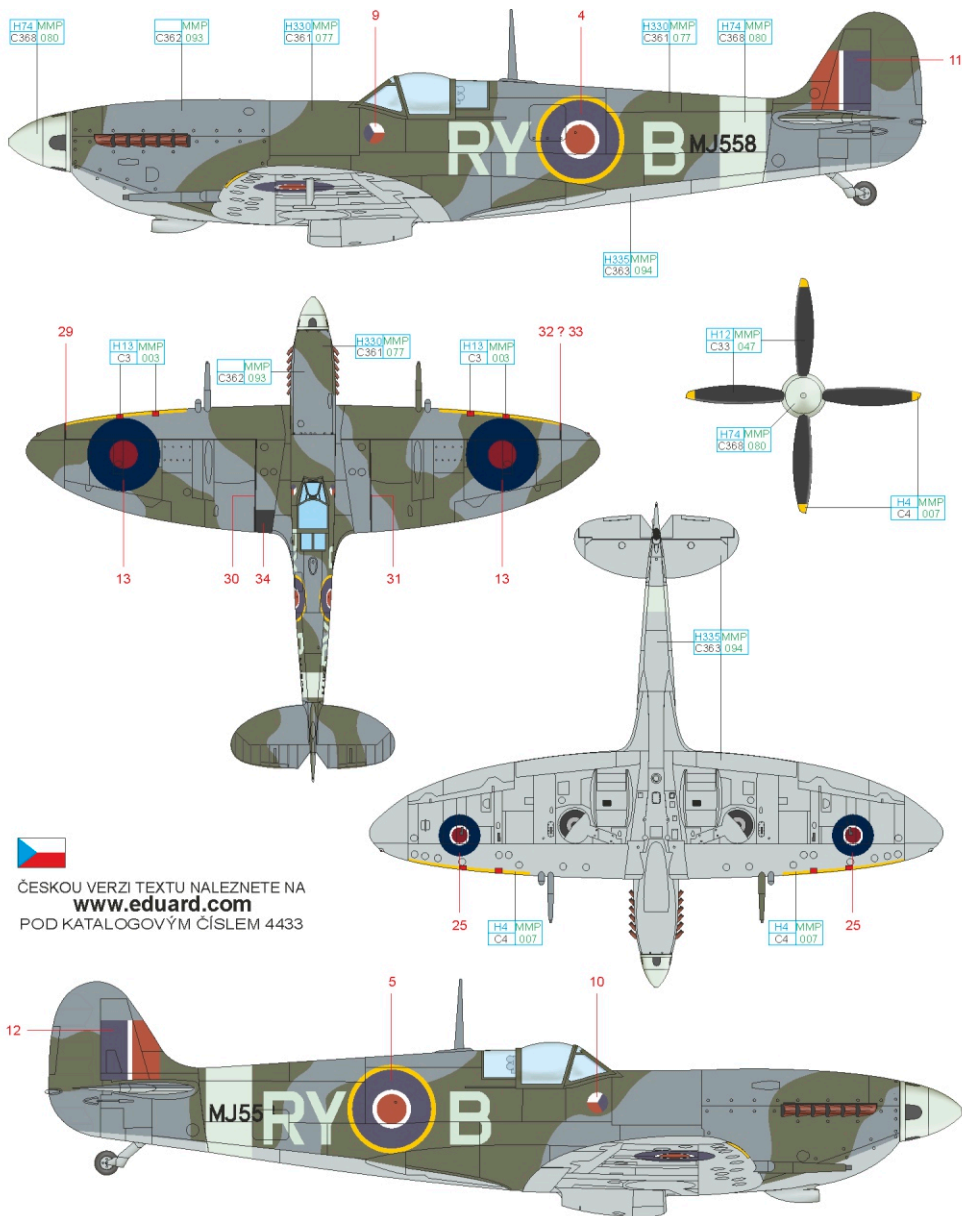

ČESKOU VERZI TEXTU NALEZNETE NA
www.eduard.com
 POD KATALOGOVÝM ČÍSLEM 4433

RED H13 MMP C3 003 **YELLOW** H4 MMP C4 007

SKY H74 MMP C368 080 **MEDIUM SEA GRAY** H335 MMP C363 094 **OCEAN GRAY** MMP C362 093 **DARK GREEN** H330 MMP C361 077 **BLACK** H12 MMP C33 047

D MJ250, No. 601 Squadron, Italy, Summer 1944

MJ250 was flown by No. 601 "County of London" Squadron from July 1944. The unit was operating from the airfields at Perugia, Loreto and Fano at that time. The aircraft was used primarily for dive-bombing operations. MJ250 survived the war but was then scrapped. MJ250 was regularly flown by F/O Desmond Ibbotson, DFC & Bar. This fighter ace is credited with 11 confirmed and four probable kills with five damaged aircraft. He died on November 19th, 1944 at the controls of Spitfire MH614. The camouflage colors were stripped down except for the upper engine and fuel tank cowling. These parts seem to be camouflaged, probably taken from another aircraft. Note the unit badge on the fin tip.

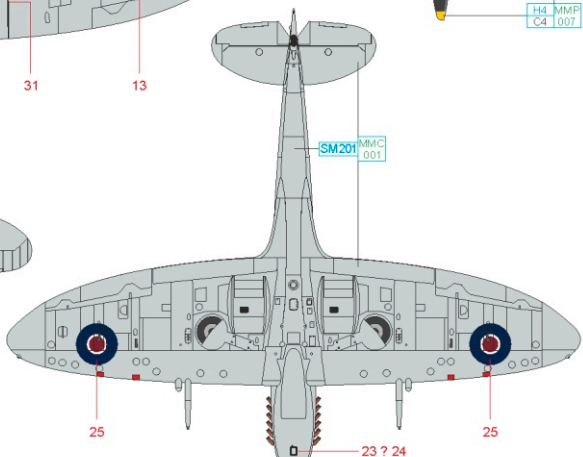
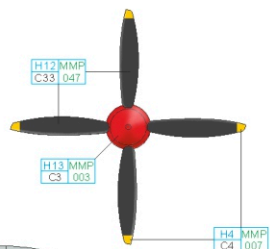
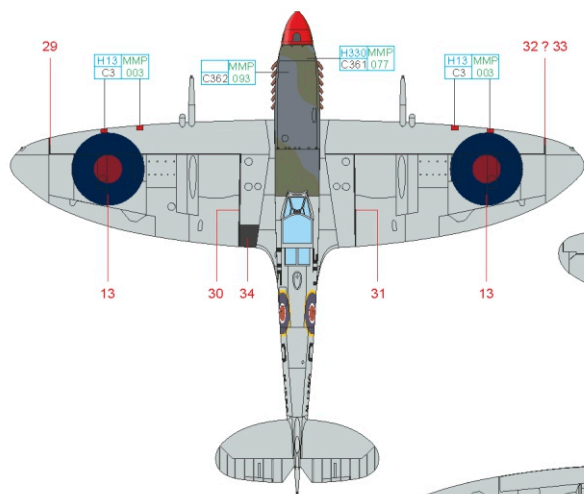
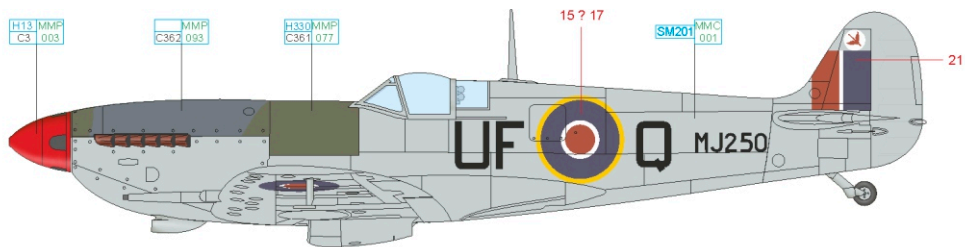

ČESKOU VERZI TEXTU NALEZNETE NA
www.eduard.com
 POD KATALOGOVÝM ČÍSLEM 4433

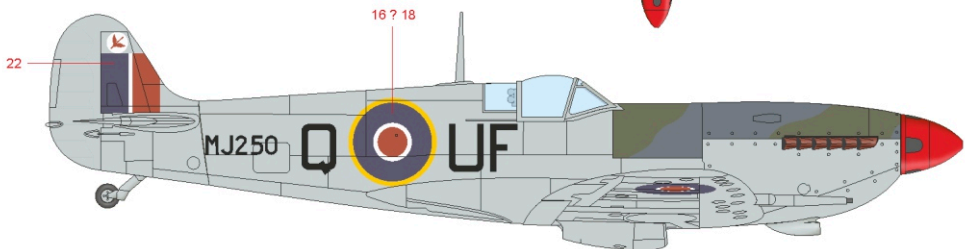

RED	H13 MMP C3 003	YELLOW	H4 MMP C4 007
SUPER FINE SILVER	SM201 MMP C 001	OCEAN GRAY	MMP C362 093
		DARK GREEN	H330 MMP C361 077
		BLACK	H12 MMP C33 047

Recommended accessories:



Cat. No. 144006
Spitfire Mk.IX
 1/144 Eduard

Fw 190D-9
 Cat. No 4461

A-4F
 Cat. No 4466

F6F-5
 Cat. No 4463

