

SUPER44

COLORS BARVY FARBEN PEINTURE 色

GSI Creos (GUNZE)		MISSION MODELS	
AQUEOUS	Mr.COLOR	PAINTS	
[H3]	C3	[MMP-003]	RED
[H11]	C62	[MMP-001]	FLAT WHITE
[H12]	C33	[MMP-047]	FLAT BLACK
[H26]	C66		BRIGHT GREEN
[H27]	C44		TAN
[H47]	C41	[MMP-012]	RED BROWN
[H51]	C11	[MMP-063]	LIGHT GULL GRAY
[H53]	C13		NEUTRAL GRAY
[H67]	C115	[MMP-057]	LIGHT BLUE
[H70]	C60	[MMP-056]	GRAY
[H77]	C137	[MMP-040]	TIRE BLACK
[H84]	C42		MAHOGANY
[H301]	C301	[MMP-099]	GRAY
[H305]	C305	[MMP-084]	GRAY

GSI Creos (GUNZE)		MISSION MODELS	
AQUEOUS	Mr.COLOR	PAINTS	
[H306]	C306	[MMP-118]	MEDIUM GRAY
[H308]	C308	[MMP-073]	GRAY
[H310]	C310	[MMP-060]	BROWN
[H321]	C321	[MMP-086]	LIGHT BROWN
[H332]	C332		LIGHT AIRCRAFT GRAY
[H335]	C338	[MMP-116]	LIGHT GRAY
[H421]	C121	[MMP-052]	BROWN VIOLET
[H422]	C122	[MMP-053]	LIGHT GREEN
	C136	[MMP-032]	RUSSIAN GREEN
	C391		INTERIOR GREEN
Mr.METAL COLOR		METALLICS	
	[MC213]	[MMM-006]	STAINLESS
	[MC214]	[MMM-001]	DARK IRON
Mr.COLOR SUPER METALLIC		METALLICS	
	[SM201]	[MMC-001]	SUPER FINE SILVER

PLASTIKOVÁ STAVEBNICE

FOTOLEPTANÉ DÍLY, EXPRESS MASK,
NEOBSAHUJE BARVY A LEPIDLO
VYROBENO V ČESKÉ REPUBLICĚ

POZOR! OBSAHUJE DROBNÉ A OSTRÉ DÍLY
VÝROBEK NENÍ HRAČKOU

SCALE PLASTIC KIT

PE PARTS, MASK,
PAINT AND GLUE NOT INCLUDED
MADE IN CZECH REPUBLIC

CONTAINS SMALL AND SHARP PARTS
COLLECTORS ITEM · NOT A TOY



8 591437 547463

MiG-21MF

1/144

Cat.No. 4435

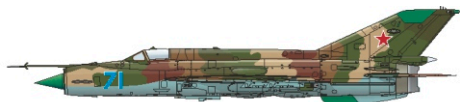

MiG-21MF, No. 71, 116. CBP (116th Combat Training Center), Privolzhsky, Soviet Union, May 1990

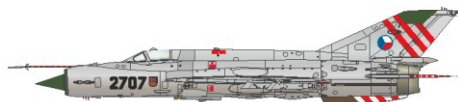

MiG-21M, 2nd Squadron, 9th Fighter-Bomber Air Regiment, Bechyne air base, October 1992



MiG-21MF, No. F_03, Tobruk, Libya, 2017

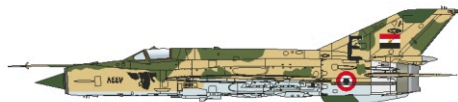

MiG-21MF, No. 8447, No. 46 Squadron, Egypt, 1973

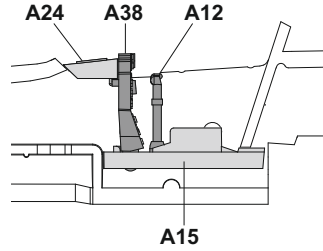
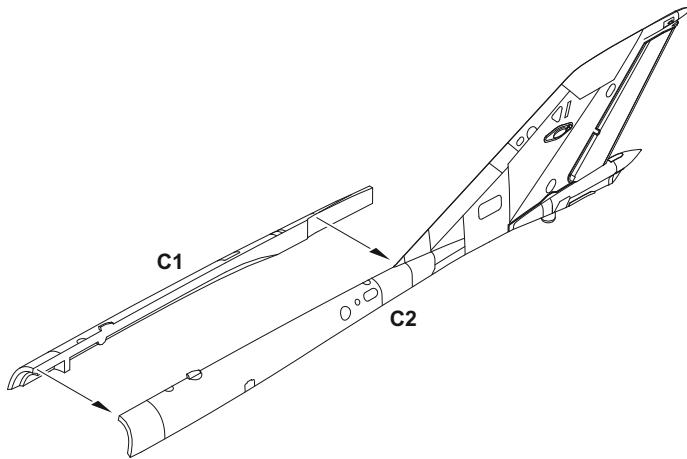
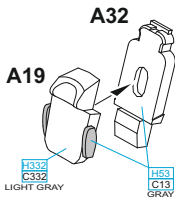
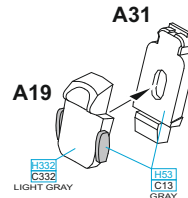
A38C391
INT. GREENH112 MMP
C33 047
FLAT BLACK**OPTIONAL:**
decal 40, 45**1** =H70 MMP
C60 056
GRAY- MARKINGS **A**; **B**H51 MMP
C11 053
GULL GRAY- MARKINGS **C**; **D****2** =H51 MMP
C11 053
GULL GRAY- MARKINGS **B**; **C**; **D**H301 MMP
C301 099
GRAY- MARKING **A****A**H112 MMP
C33 047
FLAT BLACK**A24**C391
INT. GREEN**A38****A12**H53
C13
GRAYC391
INT. GREENH53
C13
GRAY**A15****B****C****CANOPY OPEN****?****CANOPY CLOSED**

H12 MMP
C33 | 047
FLAT BLACK

A10

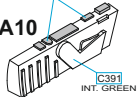

H12 MMP
C33 | 047
FLAT BLACK

A11

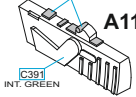

decal 41

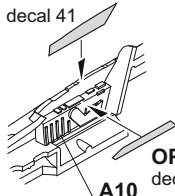

OPTIONAL:
decal 43



Don't forget
to add the nose
weight balance!

C391
INT. GREEN

A42

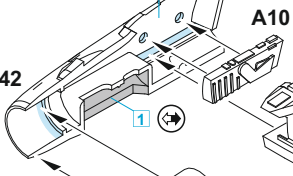

A10

A

A11

C391
INT. GREEN

A1

A37

B

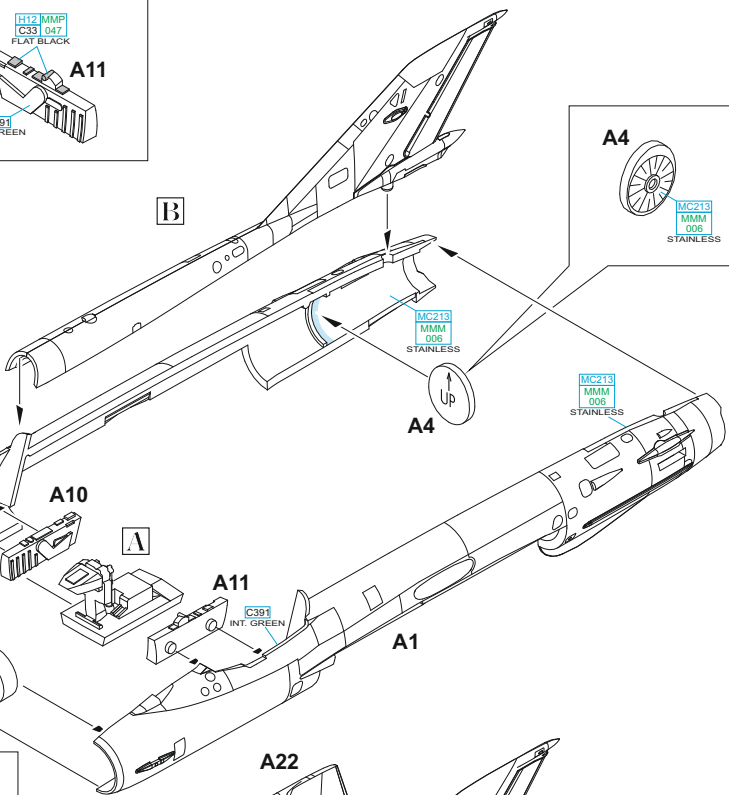

A4



MC213
MMM
006
STAINLESS

A4

MC213
MMM
006
STAINLESS

decal 42

OPTIONAL:
decal 44

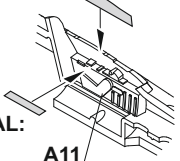

A11

A22



decal 39

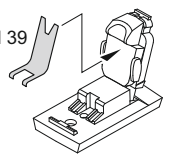

C

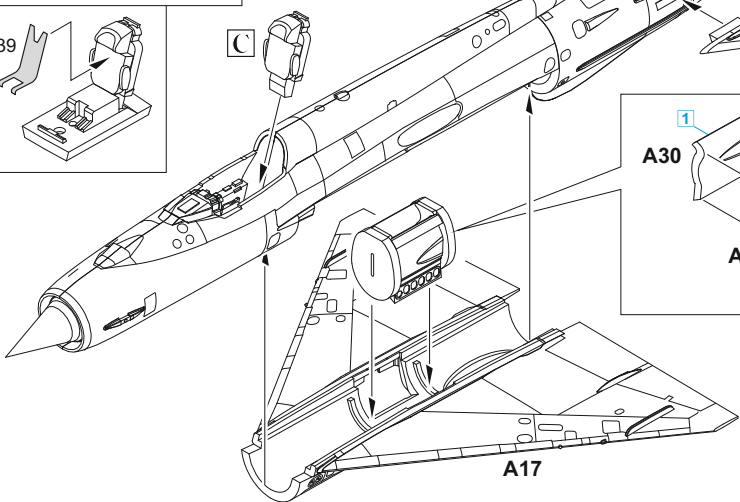

A17

1

A30

A2

A3

A29

1

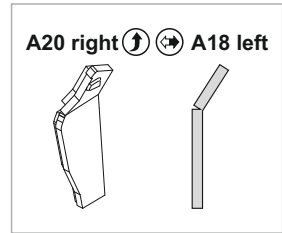
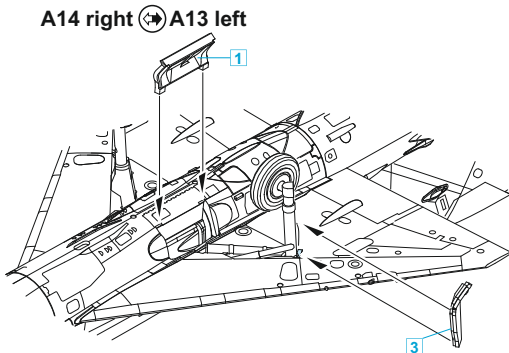
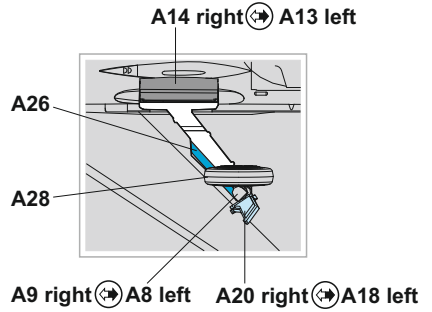
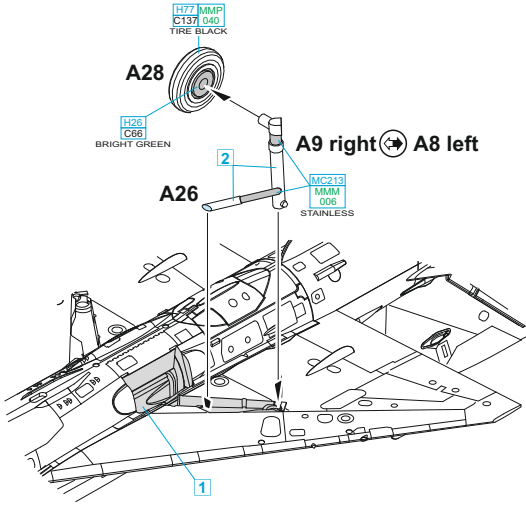

3 = **H51 MMP C11 063 GULL GRAY** - MARKINGS **A; C; D**
H70 MMP C60 056 GRAY - MARKING **B**

A20 right ↔ A18 left

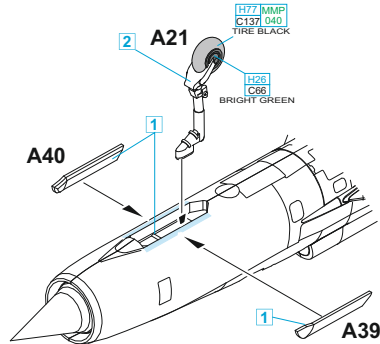
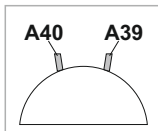

decal 30, 32, 36 - MARKING **B**

decal 31, 34, 35 - MARKINGS **A, C, D**

decal 30

decal 36 (→) decal 32

(?)

(?)

decal 34

decal 35 (→) decal 31

B1

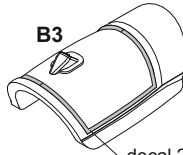
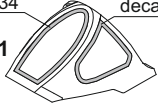

decal 28

(→)

decal 29

(?)

B3

decal 46

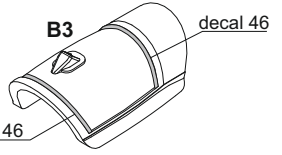

CANOPY OPEN

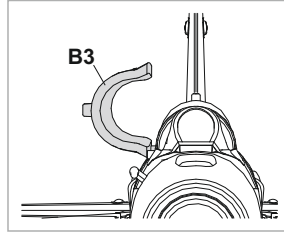
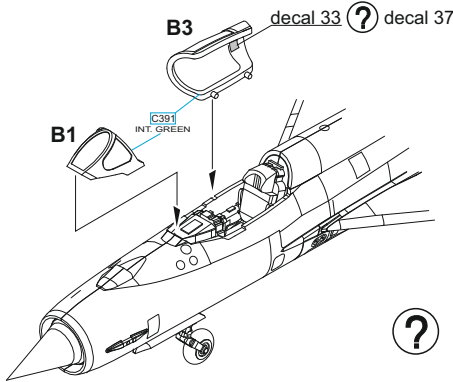

(?)

CANOPY CLOSED

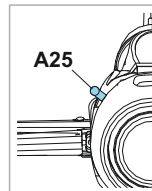
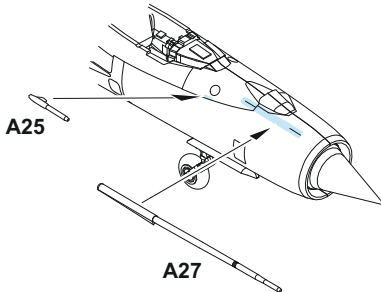
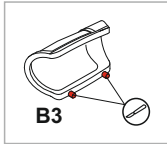
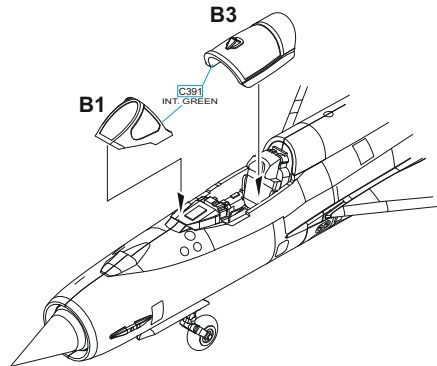

B3

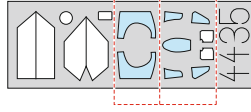
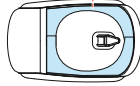

B1

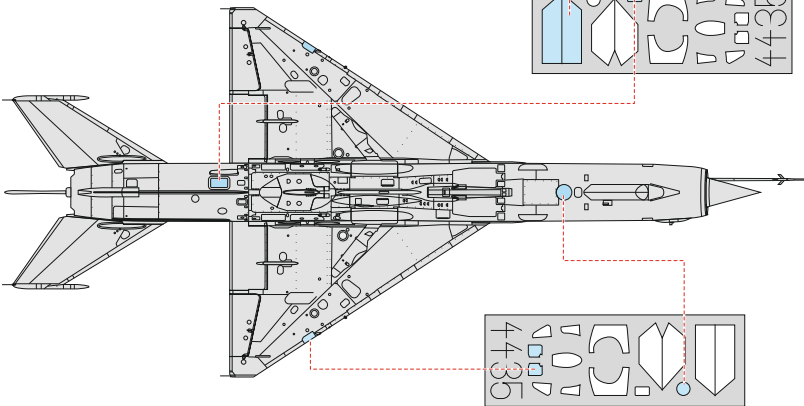
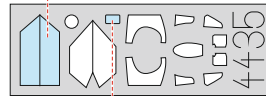
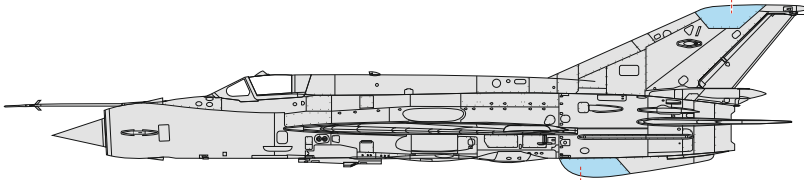
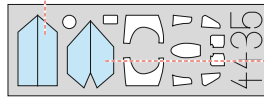
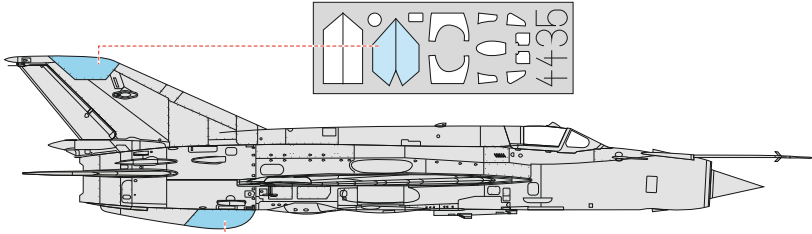

A MiG-21MF, No. 71, 116. CBP (116th Combat Training Center), Privilzhzsky, Soviet Union, May 1990

Despite the MiG-21MFs manufactured at Gorky, being intended for client states of the Soviet Union, several of these aircraft made it into Soviet service nonetheless. The only unit known to have flown the type was the 116th Combat Training Centre, based at Privilzhzsky Air Base, near Astrakhan. The aircraft was camouflaged on the upper surfaces in two shades of green and brown, supplemented by a tan. The bottom surfaces were in bluegrey. This unit used the aircraft for combat training of pilots on completion of their basic part of the curriculum.

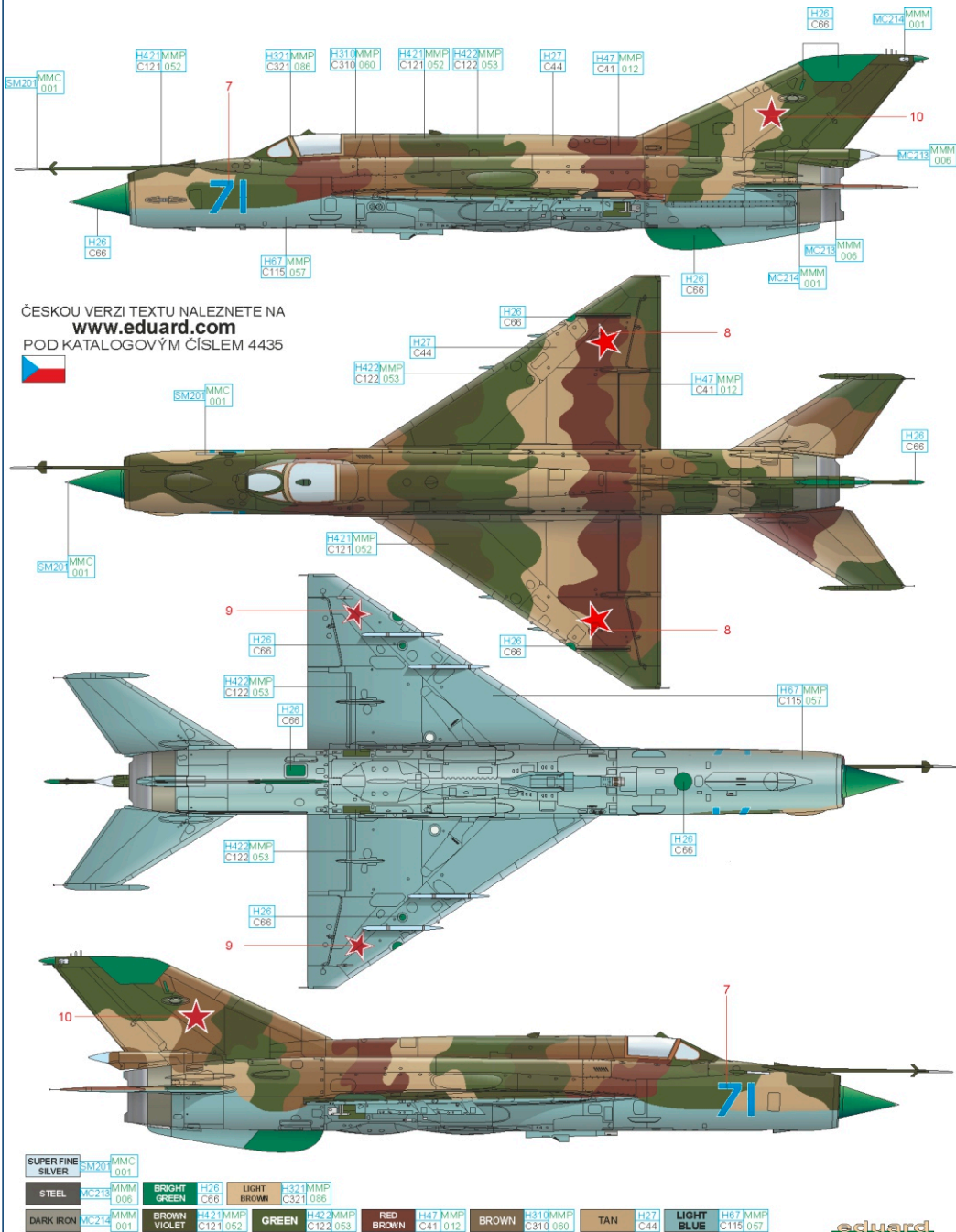

B MiG-21M, 2nd Squadron, 9th Fighter-bomber Regiment, Bechyně, October 1992

In the fall of 1989 all MiG-21MF and also L-29, Mig-21F, PF and UM flying with the 2nd Squadron of the 9th Fighter Regiment received the coat-of-arms of the city of Bechyně painted on their noses. In addition the aircraft crew chief decorated this airplane with the wide red stripes painted on the vertical and horizontal surfaces and pitot tube. After the Czechoslovakia split the aircraft was allocated to Slovakia.

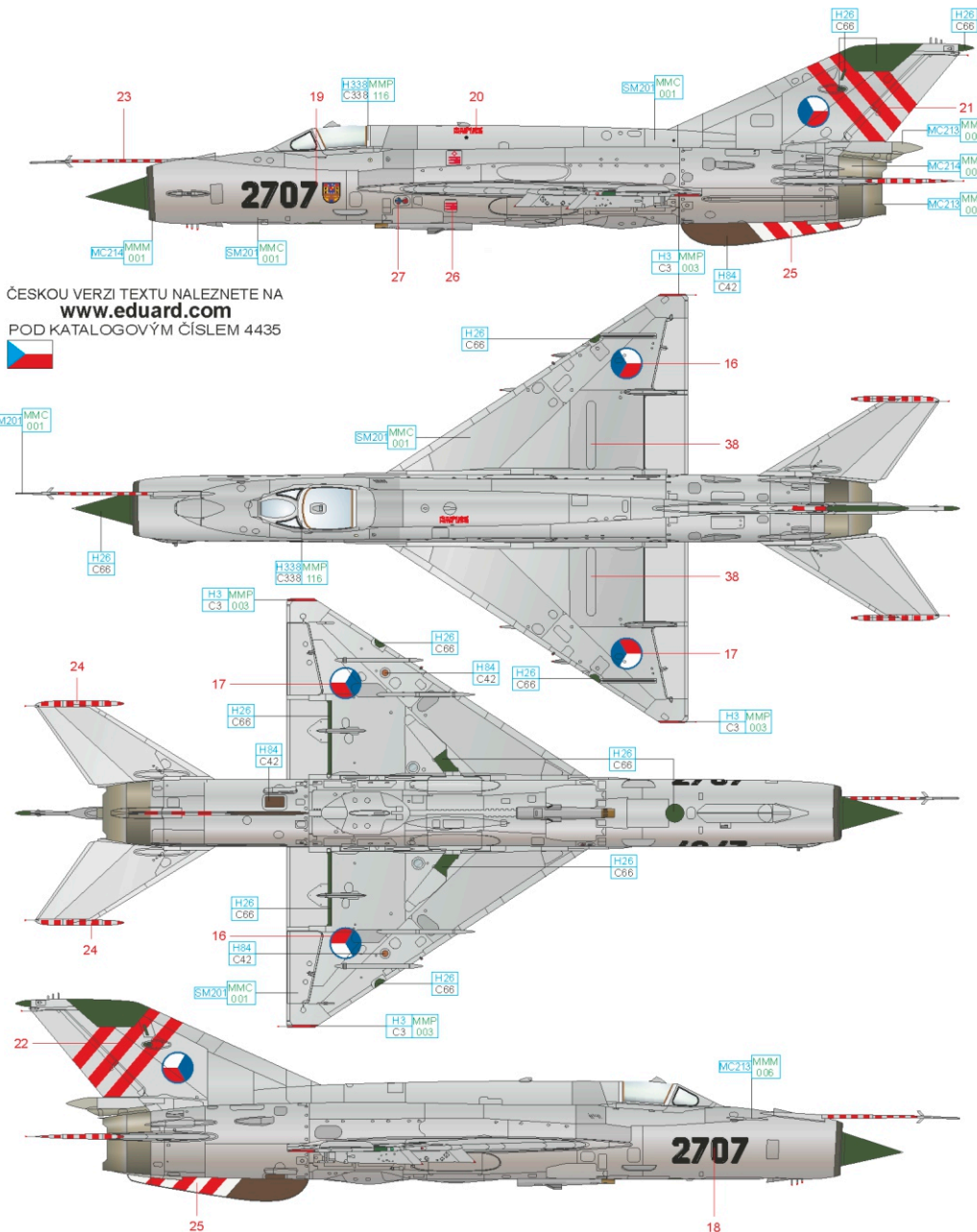

ČESKOU VERZI TEXTU NALEZNETE NA
www.eduard.com
 POD KATALOGOVÝM ČÍSLEM 4435



STEEL	MC213 MMM 006	LIGHT GRAY	H338 MMP C338 116	BRIGHT GREEN	H26 C66
DARK IRON	MC214 MMM 001	SILVER CHROME	SM201 MMC 001	MAHOGANY	H84 C42
				RED	H3 MMP C3 003

D MiG-21MF, No. 8447, No. 46 Squadron, Egypt, 1973

This is an aircraft from No 46 Squadron as it appeared during combat exercises prior to the Yom Kippur War in 1973. For the purposes of quick identification, aircraft carried a large black, outlined in white, letter on the fin. The nose carries a rendering of the goddess Nekhbet, protector of Upper Egypt. Aircraft coded 8447 survived the Yom Kippur War and was photographed in this guise at Cairo in October 1975.

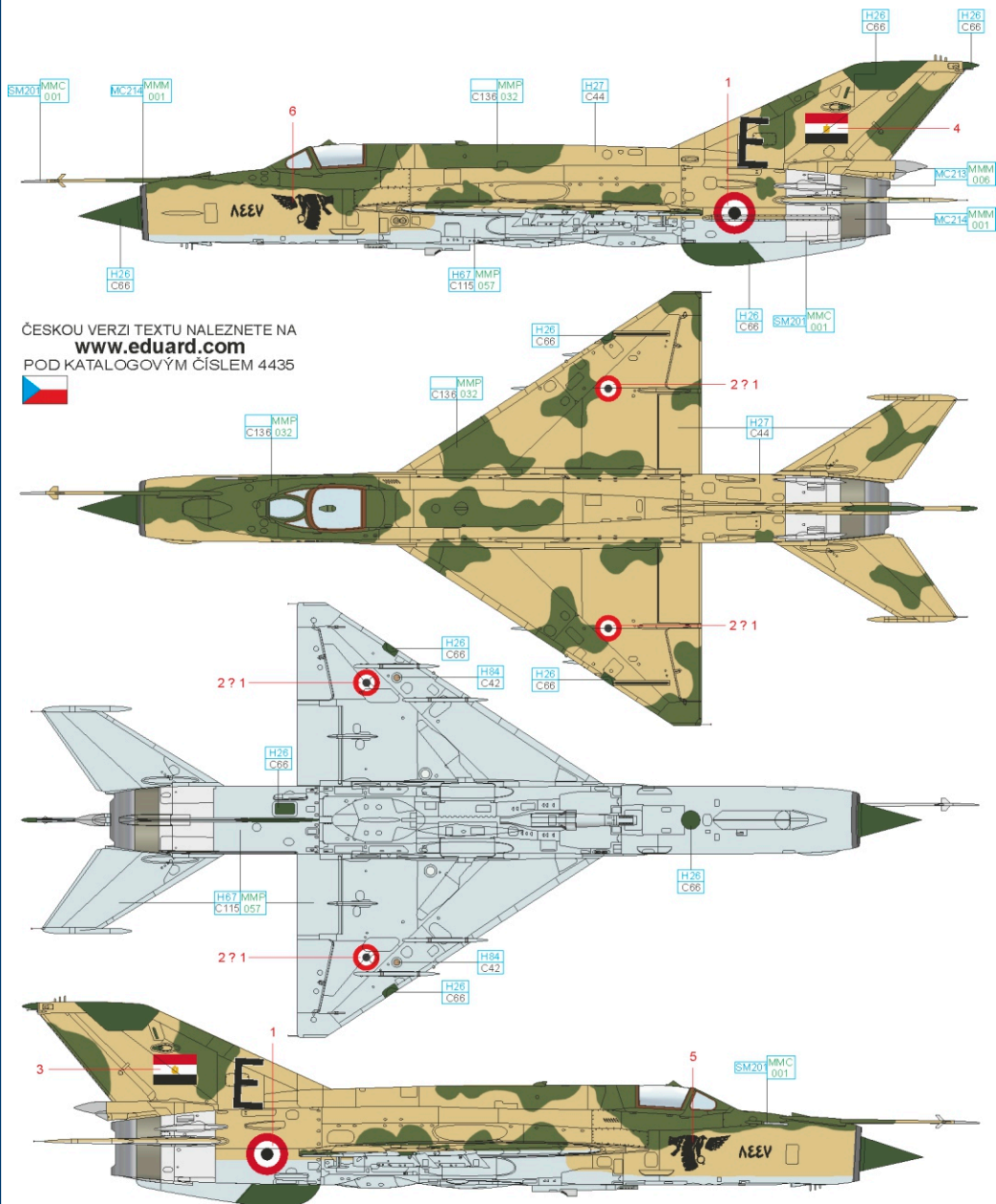

ČESKOU VERZI TEXTU NALEZNETE NA
www.eduard.com
 POD KATALOGOVÝM ČÍSLEM 4435



MAHOAGANÝ H84 C42 RED BROWN H47 MMP C41 012

STEEL X213 M/M 006 DARK IRON X214 M/M 001 SUPER FINE SILVER SM201 M/M C 001

TAN H27 C44 LIGHT BLUE H67 MMP C115 057

GREEN MMP C136 032 BRIGHT GREEN H26 C66

eduard

Recommended accessories:

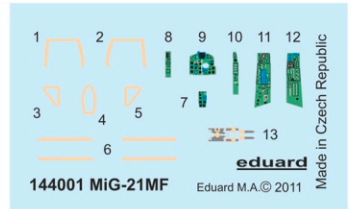
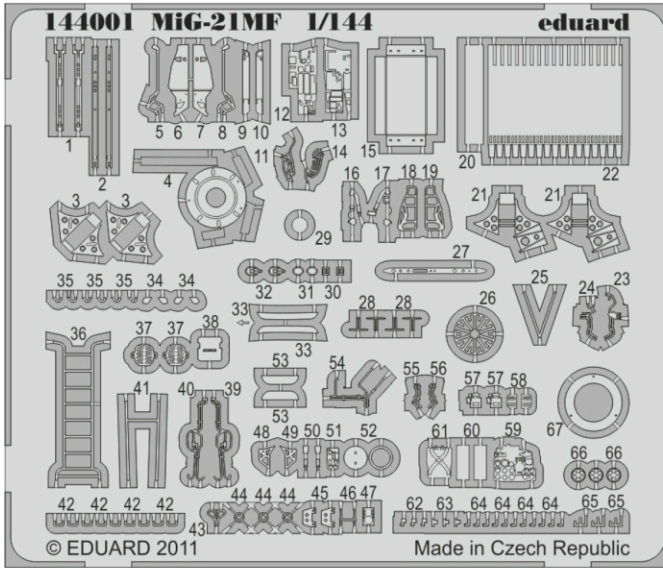

Cat. No. 144001
MiG-21MF
 1/144 Eduard

