

SUPER44

COLORS BARVY FARBEN PEINTURE 色

GSI Creos (GUNZE)		MISSION MODELS	
AQUEOUS	Mr.COLOR	PAINTS	
[H3]	C3	[MMP-003]	RED
[H6]	C6	[MMP-004]	GREEN
[H12]	C33	[MMP-047]	FLAT BLACK
[H26]	C34		SKY BLUE
[H26]	C65		BRIGHT GREEN
[H47]	C41	[MMP-012]	RED BROWN
[H66]	C119	[MMP-119]	SAND YELLOW
[H67]	C115	[MMP-115]	LIGHT BLUE
[H77]	C137	[MMP-040]	TIRE BLACK

GSI Creos (GUNZE)		MISSION MODELS	
AQUEOUS	Mr.COLOR	PAINTS	
[H308]	C308	[MMP-073]	GRAY
[H340]	C340		FIELD GREEN
Mr.METAL COLOR		METALLICS	
[MC214]		[MMM-001]	DAKIR IRON
[MC218]		[MMM-003]	ALUMINIUM
Mr.COLOR SUPER METALLIC		METALLICS	
[SM201]		[MMC-001]	SUPER FINE SILVER 2
[SM204]			SUPER STAINLESS 2

PLASTIKOVÁ STAVEBNICE

FOTOLEPTANÉ DÍLY, EXPRESS MASK,
NEOBSAHUJE BARVY A LEPIDLO
VYROBENO V ČESKÉ REPUBLICE

POZOR! OBSAHUJE DROBNÉ A OSTRÉ DÍLY
VÝROBEK NENÍ HRAČKOU

SCALE PLASTIC KIT

PE PARTS, MASK,
PAINT AND GLUE NOT INCLUDED
MADE IN CZECH REPUBLIC

CONTAINS SMALL AND SHARP PARTS.
COLLECTORS ITEM · NOT A TOY



MiG-15bis

1/144

Cat.No. 4445

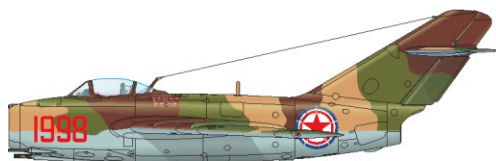

flown by Maj. Mikhail Ivanovich Mikhin, 518th IAP, North Korea,
May 1953

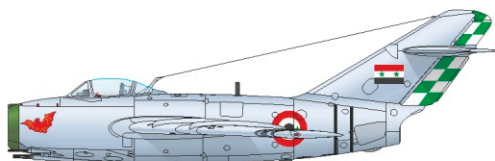

No. 20 Squadron, Egypt, Late 50s / Early 1960

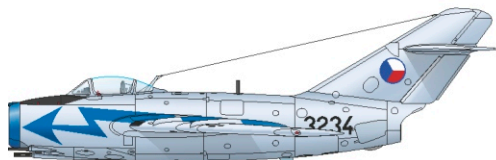

c/n 613234, flown by kpt. Oldřich Paldus, 15. slp, Cottbus Airfield,
German Democratic Republic, August 30th, 1957

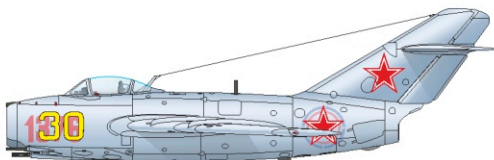

c/n 1315376, ex 64th IAK, Soviet Union, mid 50'

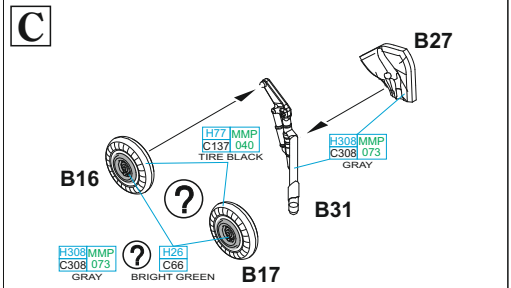
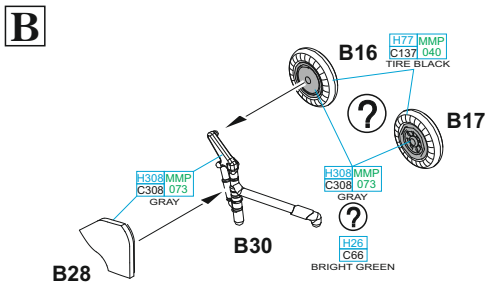
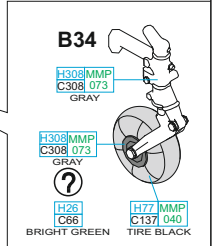
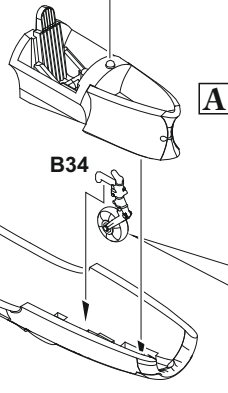
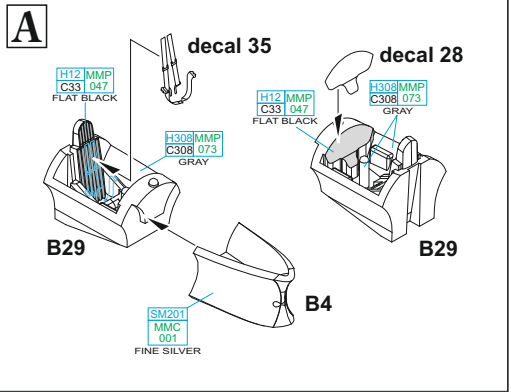
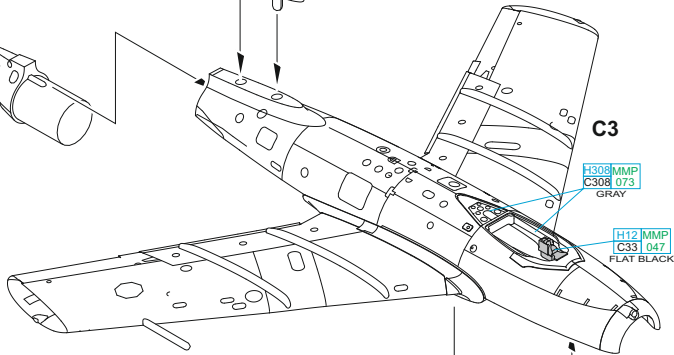
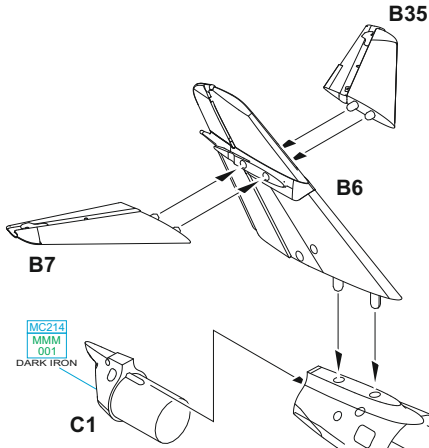

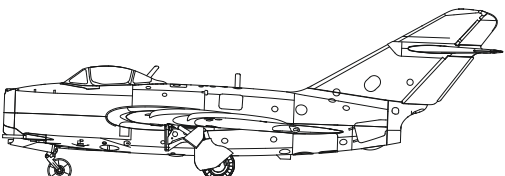
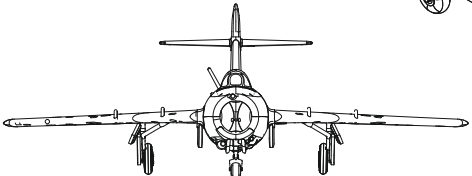
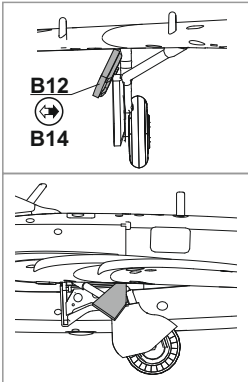
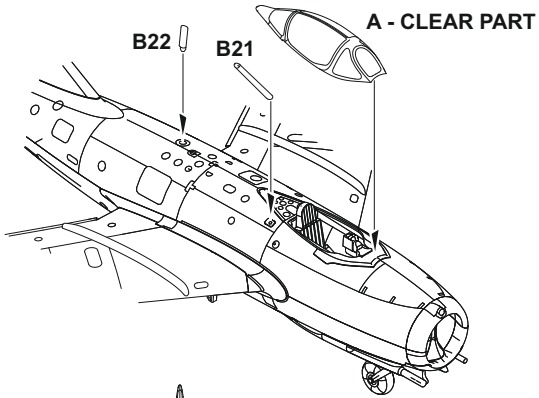
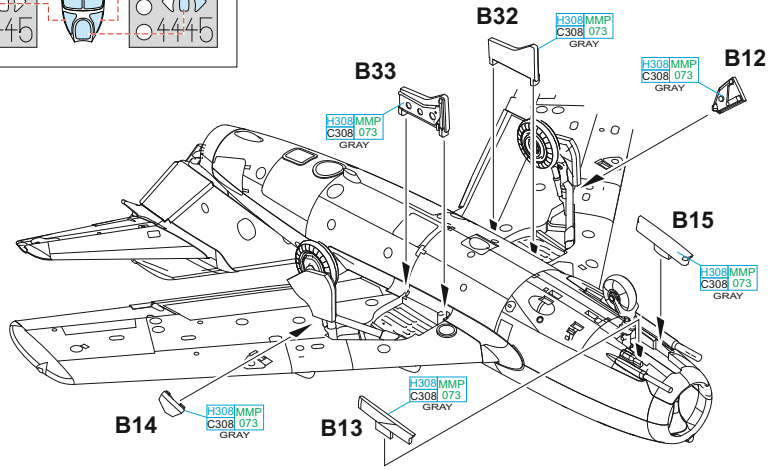
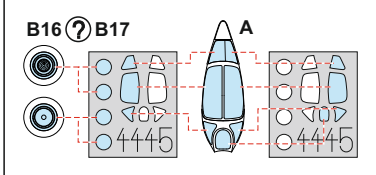
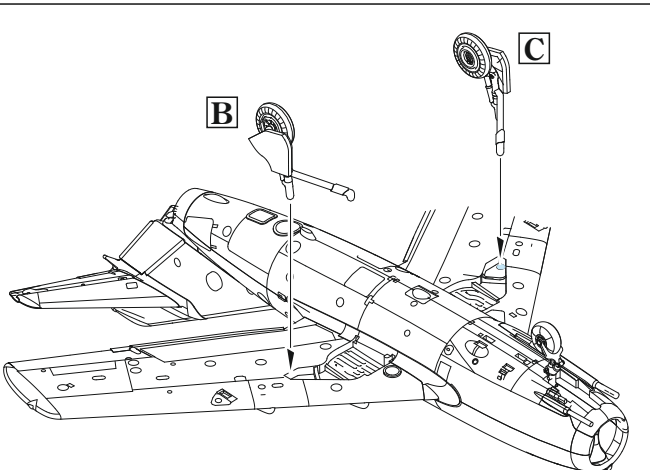
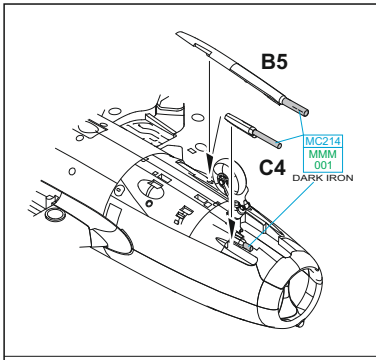

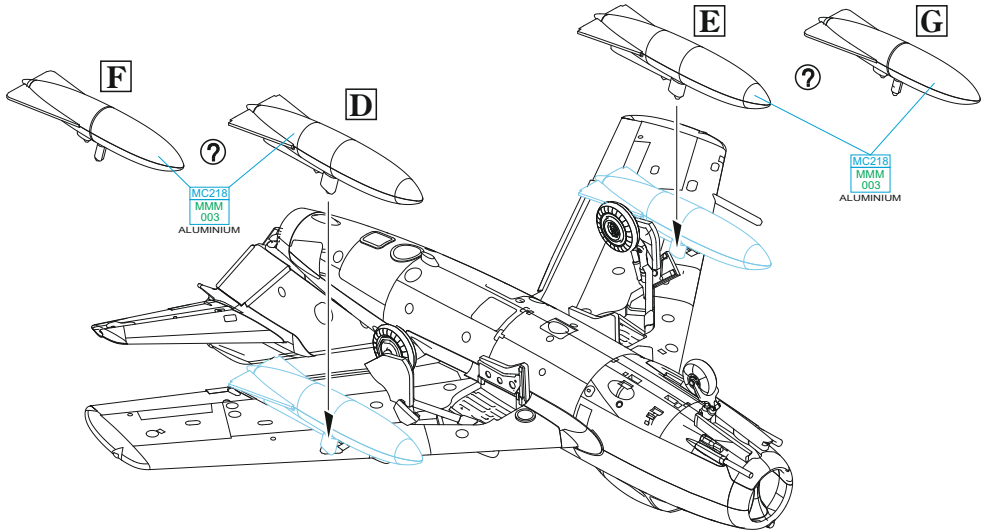
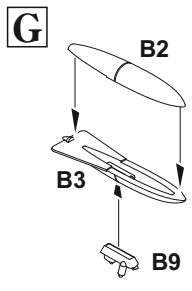
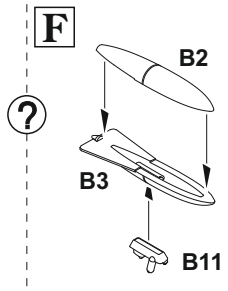
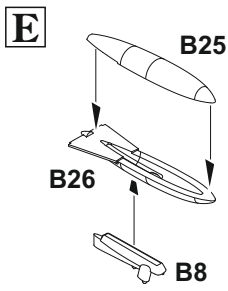
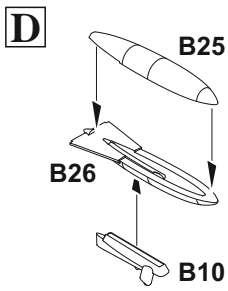

? TO CHOOSE EXTERNAL FUEL TANKS OPTION PLEASE FOLLOW YOUR REFERENCE

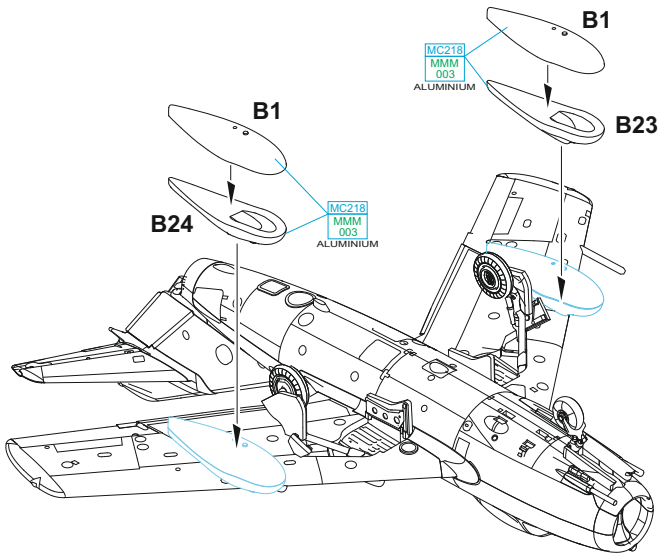

A flown by Maj. Mikhail Ivanovich Mikhin, 518th IAP, North Korea, May 1953

Mikhail Mikhin was born on October 25th, 1923 and right after the graduation from the high school he started his pilot training finishing it in the end of 1944. He did not manage to participate in any combat during the World War Two, however he participated in the air combat over Korea where he was deployed in July 1952 with the entire 518. IAP. The unit remained in the combat zone until the end of hostilities, Major Mikhin shot down 9 enemy aircraft in total (7 x F-86, 2 x F-84) for which accomplishment he was awarded the title Hero of the Soviet Union on July 14th, 1953. He remained in the active service of the Red Army Air Force after the Korean War and retired with the rank of Major General in 1980. He passed away on March 25th, 2007 in St. Petersburg.

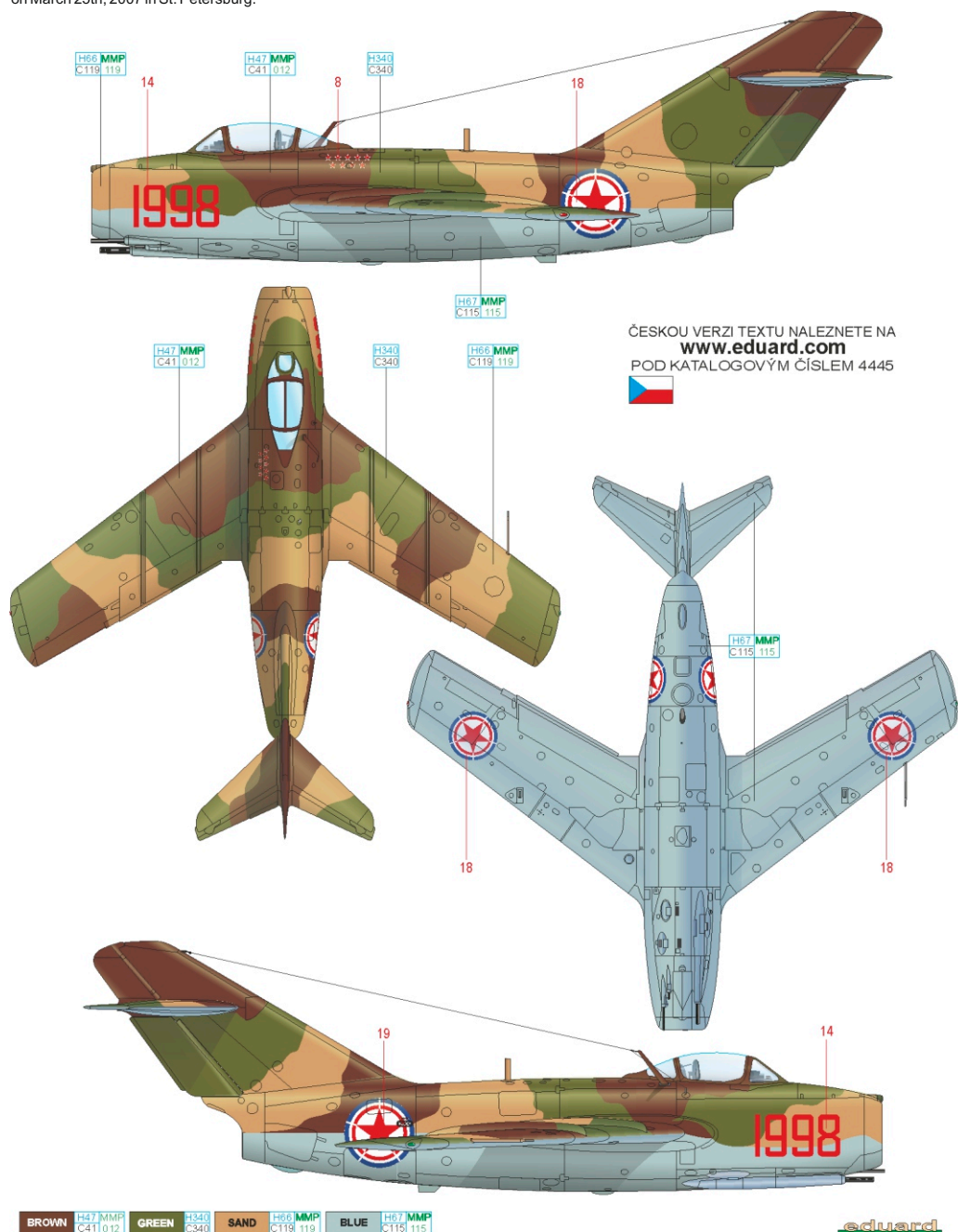

B No. 20 Squadron, Egypt, Late 50s / Early 1960s

Egypt purchased a total of 110 MiG-15bis aircraft from Czechoslovakia. This particular aircraft served with No. 20 Squadron of the United Arab Republic Air Force. The United Arab Republic was a federation of Egypt and Syria that lasted from 1958 to 1961. Egypt kept this name till 1971. No. 20 Squadron was based at Deversoir, El Qabrit and Inshas air bases.

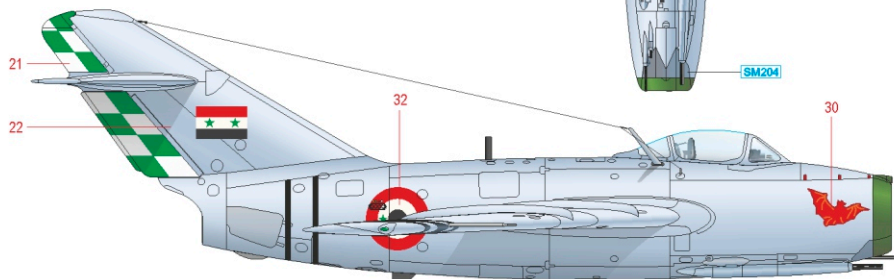
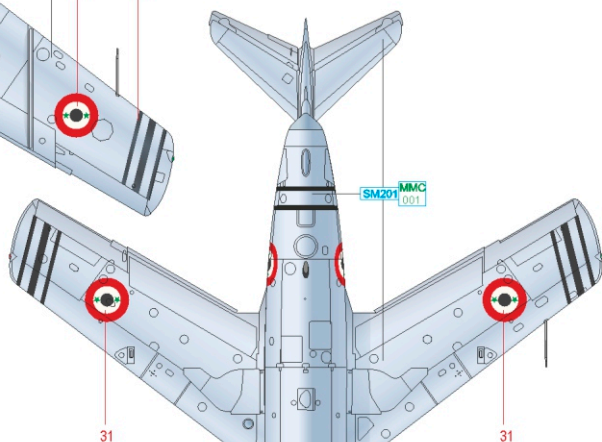
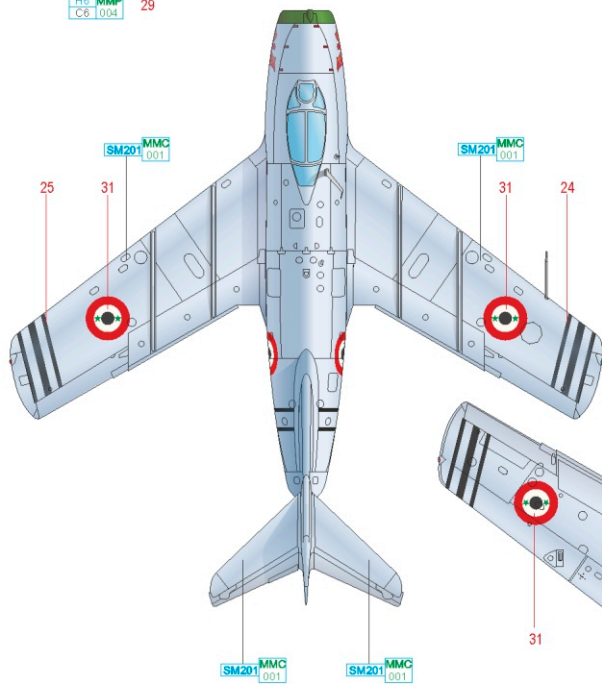
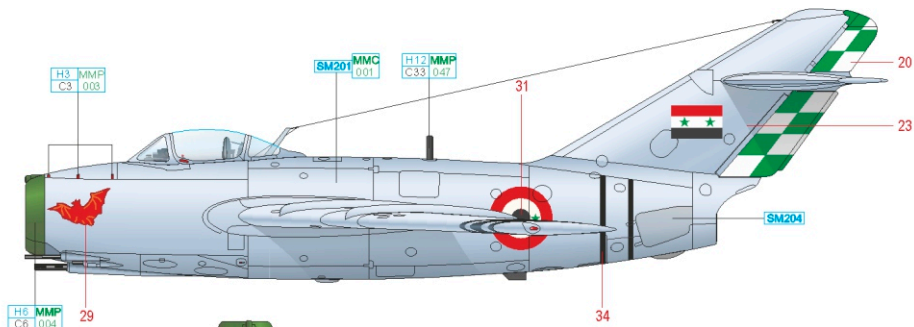

ČESKOU VERZI TEXTU NALEZNETE NA
www.eduard.com
 POD KATALOGOVÝM ČÍSLEM 4445



RED	H3 MMP C3 003	BLACK	H12 MMP C33 047	SUPER STAINLESS	SM204	SUPER FINE SILVER	SM201 MMC 001
GREEN	H6 MMP C6 004						

C/n 613234, flown by kpt. Oldřich Paldus, 15. slp, Cottbus Airfield, German Democratic Republic, August 30th, 1957

A group of three MiG-15bis from 15th FR, Zatec Air Base, took part in the 2nd Cultural and Sport Celebration that was organized in Cottbus, German Democratic Republic in late August, early September, 1957. The distinctive blue marking was applied on these aircraft especially for this event. During the display, a tragedy nearly occurred when MiGs 3234 and 3233 collided in mid-air. 3234 lost the tip of its left horizontal stabilizer, but the pilot managed to maintain control over the aircraft till he could set it down. Two of pilots of this display team, Oldřich Paldus and Vaclav Polasek headed to 11th FR in 1958, when 15th FR was disbanded. In 1959 Capt. Jaromir Palecny joined them – all three pilots were not tall at all, so the team was unofficially dubbed 'Trio Prckos' ('The Three Squirrels' in English).

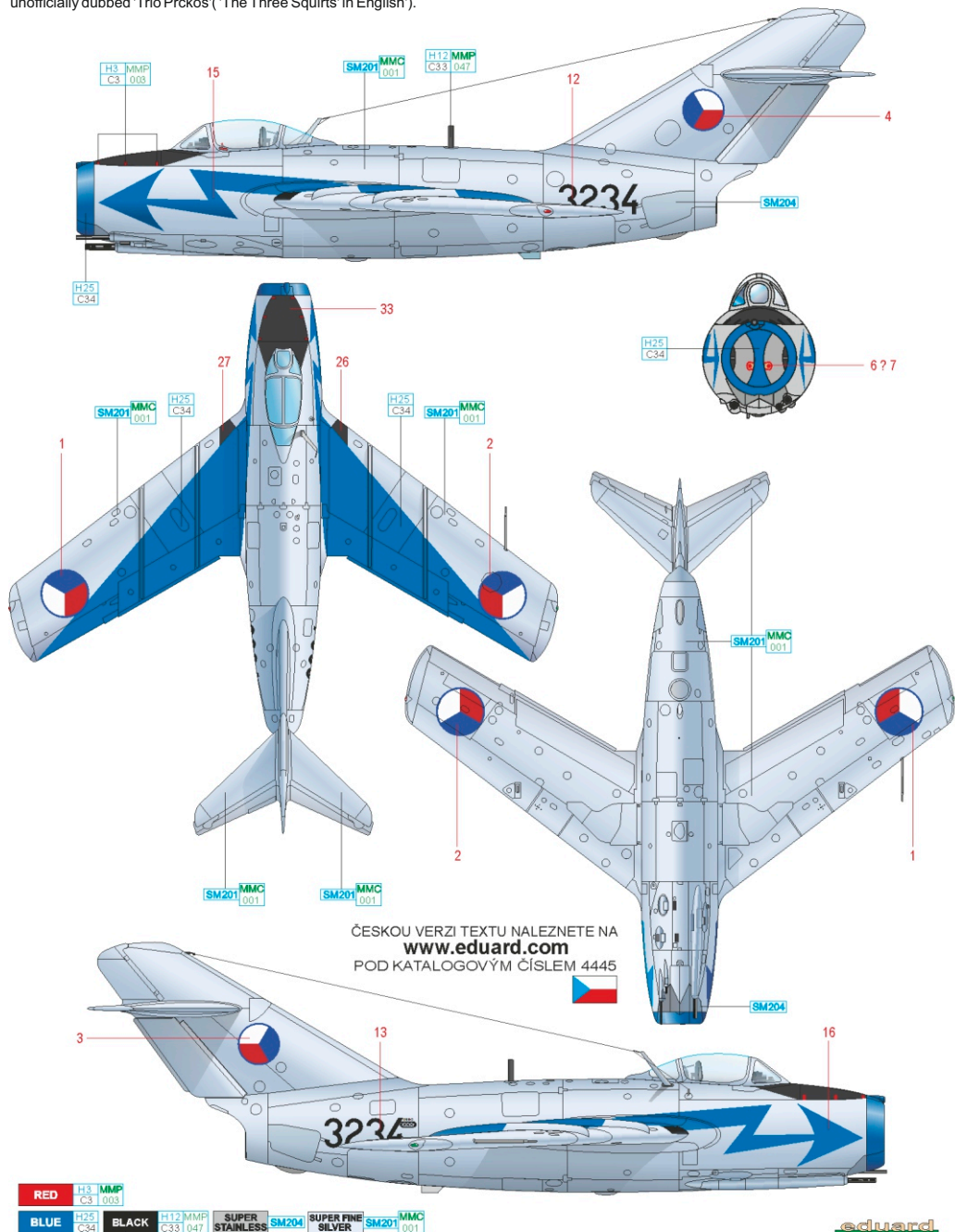

D c/n 1315376, ex 64th IAK, Soviet Union, mid 50'

This MiG formerly took part in the Korean War – the communist attempt to occupy the entire Korean peninsula. It wore red number '1976' on its fuselage. Back in the USSR, it was simply overpainted with the yellow 30, as well as replacing the North Korean national insignia. The North Korean national insignia was simply an extension of the Soviet red star, removing the white outline and adding the red and blue circles. Based on photographic evidence, the insignia was applied on the fuselage only. It is possible these were painted on the lower surface of the wings as well.

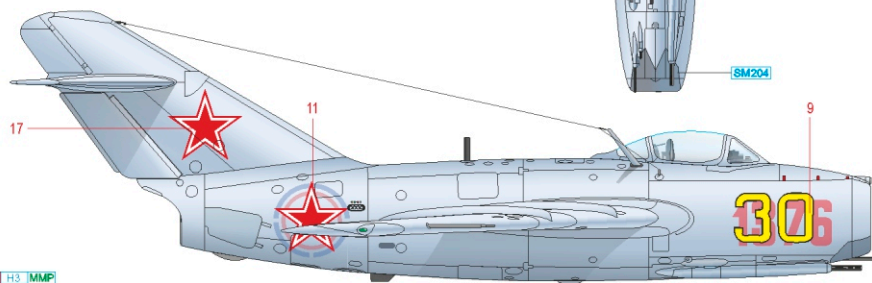
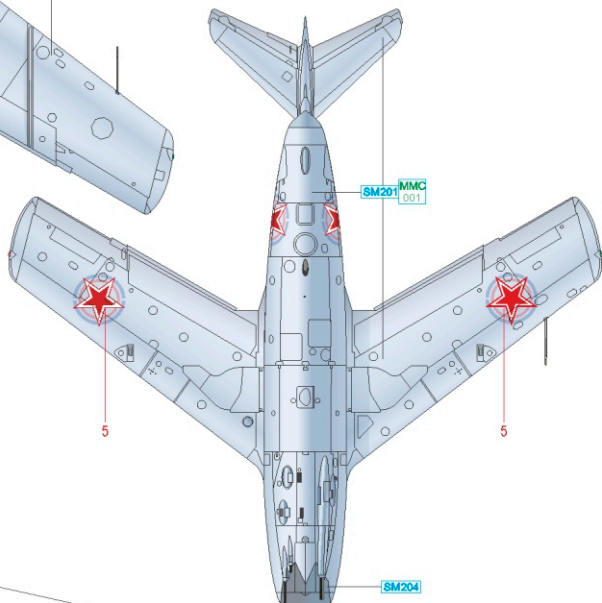
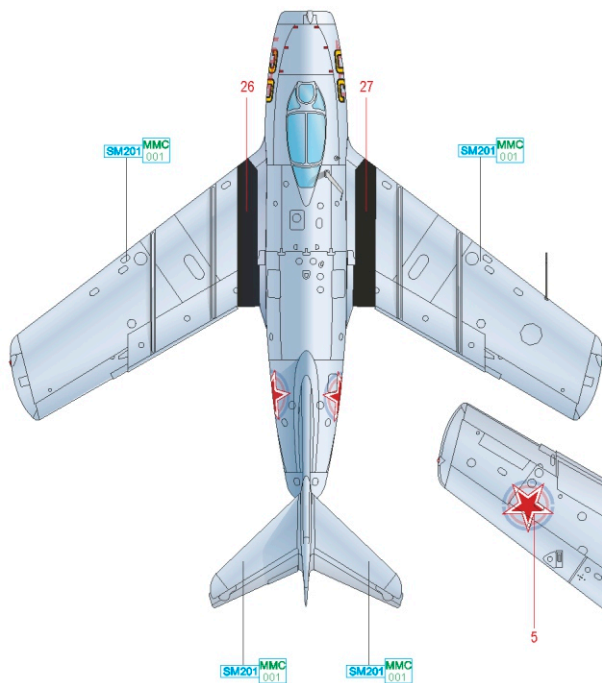
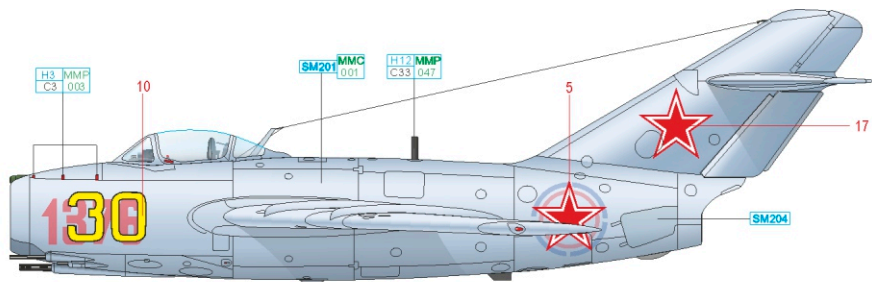

ČESKOU VERZI TEXTU NALEZNETE NA
www.eduard.com
POD KATALOGOVÝM ČÍSLEM 4445



RED H3 MMP C3 008

BLACK H12 MMP C33 047

SUPER STAINLESS SM201

SUPER FINE SILVER SM201 MMC 001

eduard