

L-29 Delfin

eduard

1/72 Scale Plastic Model Kit

ProfiPACK
edition



item No. 7096

The onset of military jets necessitated new training airplanes, preparing student pilots for demanding machinery. The L-29 Delfin became a very successful design for this purpose.

The Czechoslovak Ministry of National Defense (MNO) specified the tactical and technical requirements for a future jet trainer in 1955, demanding use of the domestic turbojet M710 engine with one stage axial-flow compressor, which was under development at the time.

The project took off under the C-29 designation with Zdeněk Rublič starting the work on the design immediately. Later on, Karel Tomáš joined him as a second main designer, and both were assisted by younger prospect Jan Vlček, who, in 1960, took the lead role in further development, as both the main designers retired. Later on Vlček used his experience from L-29 in design of successor L-39 Albatros.

Shortly after the start of pre-design work the C-29 attracted attention of Soviet officials, who were acquainted with the project in early stage of development. The reason was obvious: while Czechoslovakia needed only some 100 of trainers, the demand of Soviet Union promised orders of thousands of them. The first consultations between Czech and Soviet representatives took place in Moscow in May 1956 and the requirement for turbojet engine with a robust radial-flow compressor instead of axial-flow one emerged as one of the main requests from Soviet side. A subsequent meeting in September 1956 confirmed it definitively, so engine designers of the Motorlet Jinonice company started work on engine M701 with radial-flow compressor.

Other demands from the Soviets included extension of the flight endurance from 70 minutes to 120 minutes and also reduction of the landing speed from 105 mph (170 km/h) to 81 mph (130 km/h) was required. The wing area had to be increased from 17.5 m² to 19.8 m² with original split flaps replaced by the more efficient slotted flaps to achieve such a low speed safely.

First time airborne

At the beginning of 1957, production of the first five prototypes of L-29 (as the project was newly designated), was approved. Three of these were to be used for flight tests, one for structural tests and one, uncompleted, served as technological demonstrator. Since the M701 was not yet available, substitution had to be sought elsewhere and, as there was no suitable engine within the WP countries, it needed to be sourced from western (i.e. NATO) countries with the need to circumvent existing embargoes. Attempts to acquire two British Armstrong Siddeley Viper engines ended with smuggling them through Switzerland by Jaroslav Bejšovec, employee of the state owned Foreign Trade Company (PZO). The engines lacked technical documentation and also some parts like starter or gearbox, so they had to be manufactured locally without any technical support from the engine producer.

The prototype No. 3 took off for the very first time on April 5, 1959 at 2:50 pm with Rudolf Duchoň behind the controls. The XL-29.03 proved it was easy to fly, but later on, at higher speeds, problems with tail vibrations and aileron flutter emerged. During the attempts to solve the problems, prototype No. 1 was prepared to start flight tests with new M701 engine. The XL-29.01

conducted its maiden flight on July 12, 1960 and later on also prototypes Nos. 2 and 3 got the new M701 turbojet. At the end of 1960 representatives of the MNO approved production of ten aircraft provided several lasting problems would be adjusted.

Comparative trials success

The grounds for the success of L-29 lies in victory in comparative trials with two competitors: the Polish TS-11 Iskra and the Soviet Jak-30. The trials took place on August 21, 1961 in Soviet Monino and the Czechoslovak team showed up with the prototype No.3 upgraded with most of latest changes adopted already for serial production. Although the L-29 proved to be inferior to the competitors in terms of performance, it demonstrated best flying characteristics and had also upper hand in operational reliability. Hence was L-29 found as the most suitable for pilot training and declared winner of the trials.

After the return of the XL-29.03 from Monino (September 28, 1961), work began on some last adjustments. The horizontal stabilizer was changed and the air brakes got eight, then sixteen circular holes. During 1962, the production of the first ten aircraft was under way and starting with 11th example a new front fuselage was adopted (by 9,8 inch/ 25 cm longer). Also the rudder was changed and air brakes returned to unperforated variant. The intergovernmental agreement on L-29 delivery was signed between Czechoslovakia and Soviet Union in February 1963 and it put production under high stress as the USSR demanded the delivery of 2500 pieces over five years. Because of that, final assembly took place not only in Aero Vodochody (total production of 1943 L-29s), but also in second factory Let Kunovice (total production of 1722 L-29s, all destined for the USSR and other WP countries). The next development of the L-29 led to the L-29 R reconnaissance variant, the L-29 A aerobatics lightweight version and one seater L-29 RS used for advanced training. The trade name Delfín (Dolphin) was adopted in 1963,

Dolphin Warrior

Although the L-29 was a dedicated trainer, it has also been involved in several combat operations during its service, because it was exported to African and Middle Eastern markets with unstable countries. The first non WP customer was Syrian Arab Republic in 1964. The L-29 was used in combat for very first time in Nigeria, flown by government forces against the rebels led by General Ojukwu in 1967. Upon rebellion in Uganda, the L-29s attacked ground targets with rockets and bombs when used against the governmental forces of General Amin in 1978. L-29s were also used by Egypt in the Arab-Israeli wars. They were modified to allow two pylons, each with four 80mm rockets, under each wing. It was quite rough modification of the wing design, which luckily went well...

All in all, the Aero L-29 Delfín served successfully with 24 air forces and many of them are still in flight condition in private hands. With the total of 3665 examples produced, the L-29 Delfín is so far the mostly produced jet trainer in history.

ATTENTION



UPOZORNĚNÍ



ACHTUNG



ATTENTION



注意



Carefully read instruction sheet before assembling. When you use glue or paint, do not use near open flame and use in well ventilated room. Keep out of reach of small children. Children must not be allowed to suck any part, or pull vinyl bag over the head.



Před započítím stavby si pečlivě prostudujte stavební návod. Při používání barev a lepidel pracujte v dobře větrané místnosti. Lepidla ani barvy nepoužívejte v blízkosti otevřeného ohně. Model není určen malým dětem, mohlo by dojít k požití drobných dílů.

INSTRUCTION SIGNS * INSTR. SYMBOLS * INSTRUKTION SINNBILDEN * SYMBOLES * 記号の説明

OPTIONAL
VOLBABEND
OHNOUTSAND
BROUSITOPEN HOLE
VYVRTAT OTVORSYMETRICAL ASSEMBLY
SYMETRICKÁ MONTÁŽREMOVE
ODRÍZNOUTREVERSE SIDE
OTOČITAPPLY EDUARD MASK
AND PAINT
POUŽÍT EDUARD MASK
NABARVITPLEASE, CHECK THE LATEST VERSION OF THE INSTRUCTIONS ON www.eduard.com

PARTS



DÍLY



TEILE



PIÈCES



部品

PLASTIC PARTS

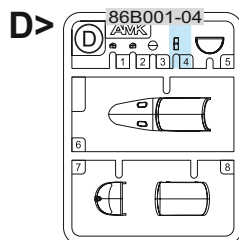
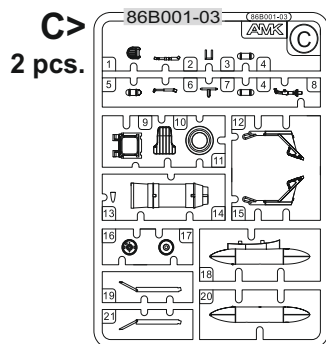
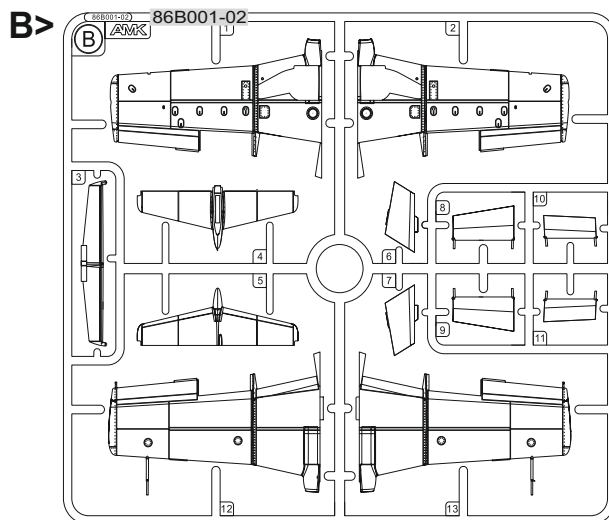
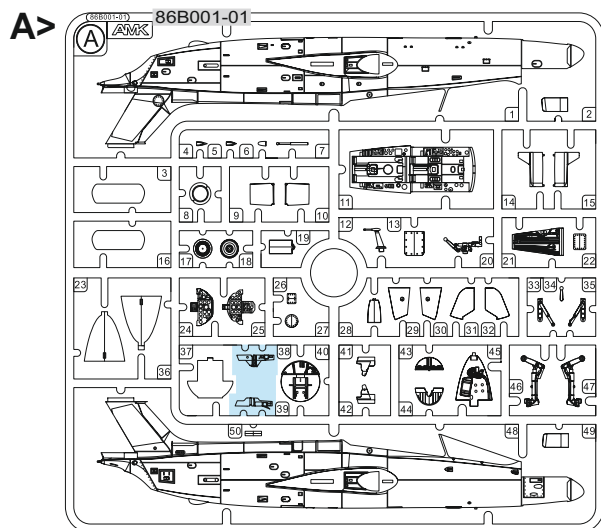

FILM

□ □ □ □
7096
L-29 Delfin

PE - PHOTO ETCHED DETAIL PARTS

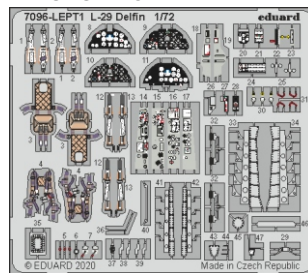
eduard
MASK

-Parts not for use. -Teile werden nicht verwendet. -Pièces à ne pas utiliser. -Tyto díly nepoužívejte při stavbě. - 使用しない部品

COLOURS



BARVY



FARBEN



PEINTURE



色

GSI Creos (GUNZE)		
AQUEOUS	Mr.COLOR	
H3	C3	RED
H11	C62	FLAT WHITE
H12	C33	FLAT BLACK
H25	C34	SKY BLUE
H47	C41	RED BROWN
H52	C12	OLIVE DRAB
H67	C115	LIGHT BLUE
H76	C61	BURNT IRON
H77	C137	TIRE BLACK
H90	C47	CLEAR RED
H94	C138	CLEAR GREEN
H302	C302	GREEN
H313	C313	YELLOW
H317	C317	GRAY
H323	C323	LIGHT BLUE

GSI Creos (GUNZE)		
AQUEOUS	Mr.COLOR	
H328	C328	BLUE
H332	C332	LIGHT AIRCRAFT GRAY
H334	C334	BARLEY GRAY
H337	C337	GRAYISH BLUE
H338	C338	LIGHT GRAY
H413	C113	YELLOW
	C92	SEMI GLOSS BLACK
	C128	GRAY GREEN
Mr.METAL COLOR		
MC213		STAINLESS
Mr.COLOR SUPER METALLIC		
SM201		SUPER FINE SILVER
Mr.COLOR GX		
GX05		SUSIE BLUE

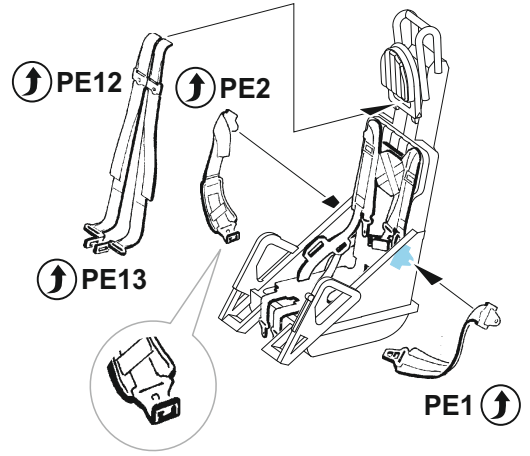
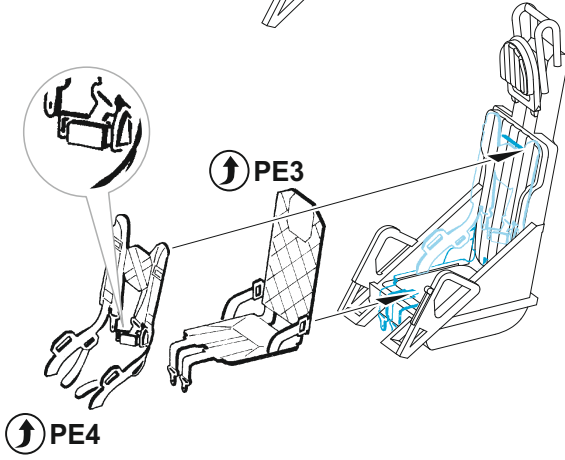
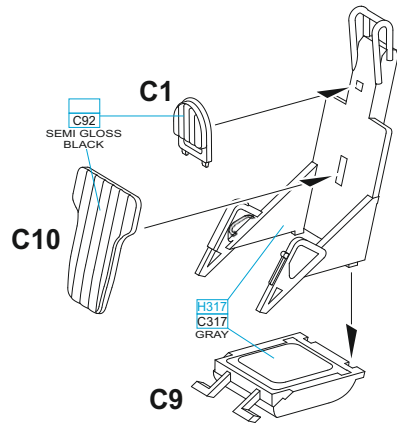
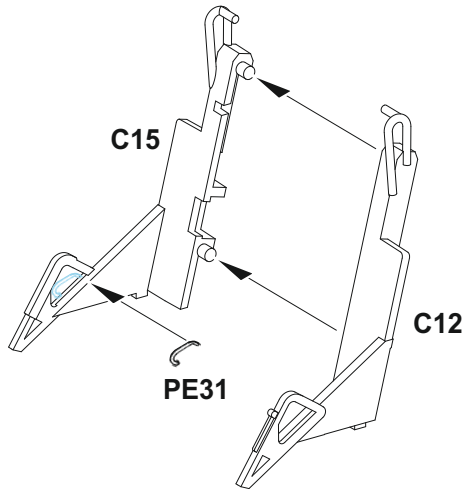
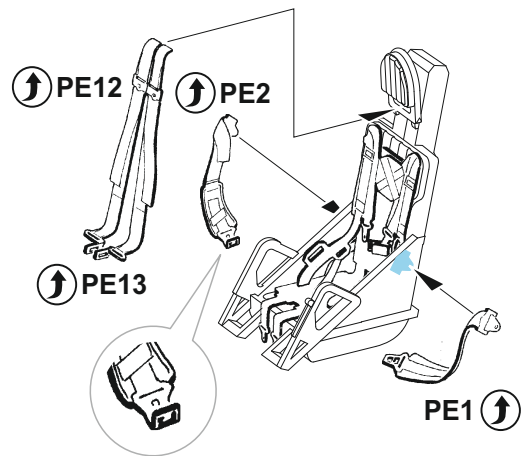
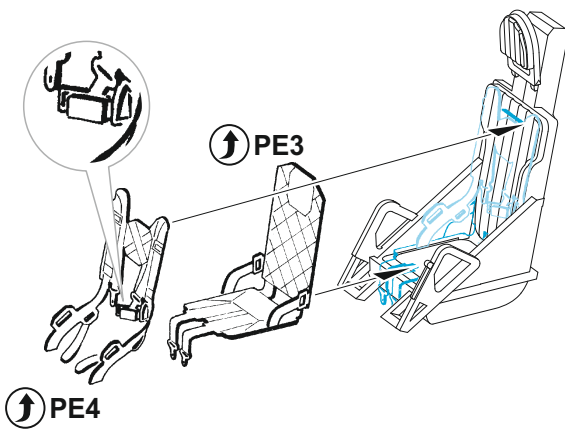
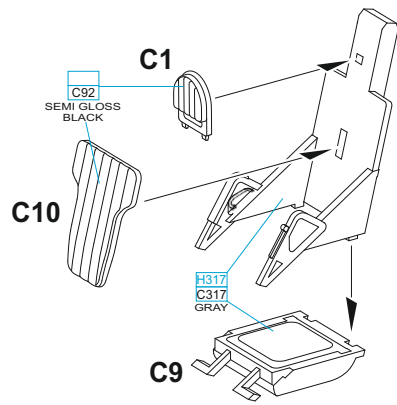
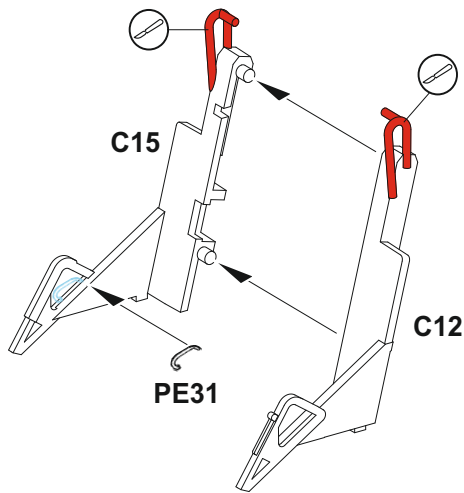
A**B**

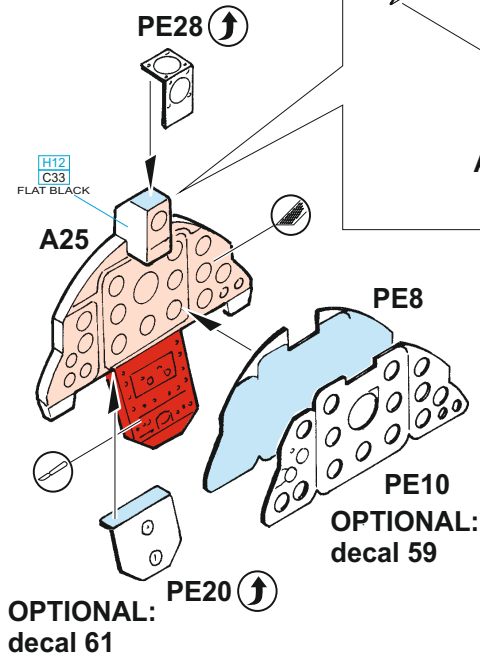
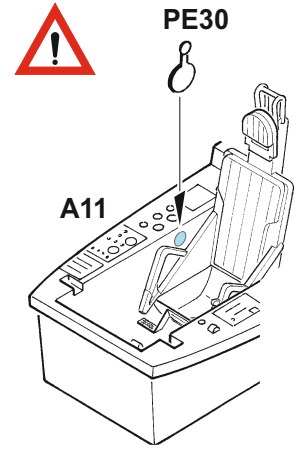
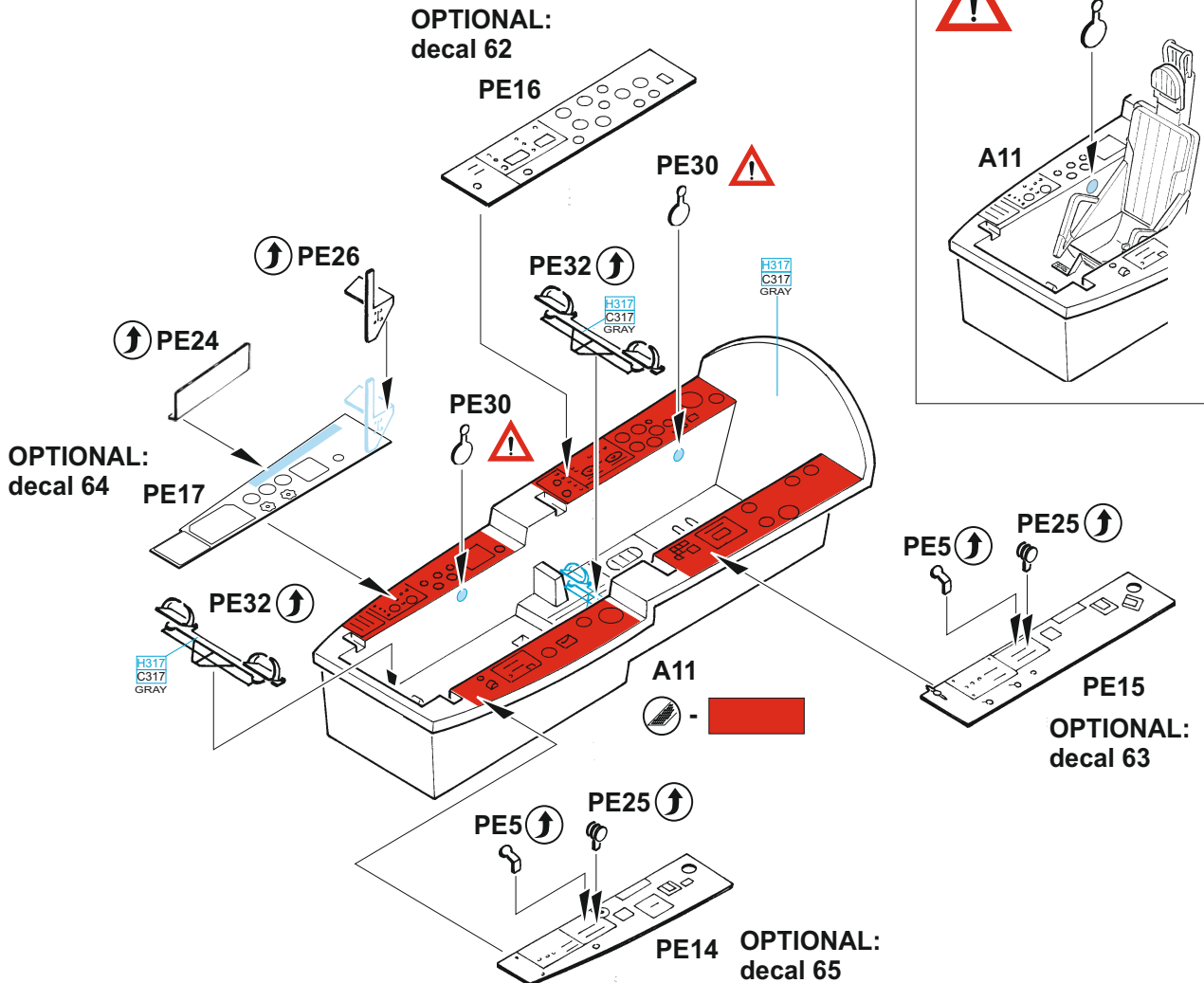
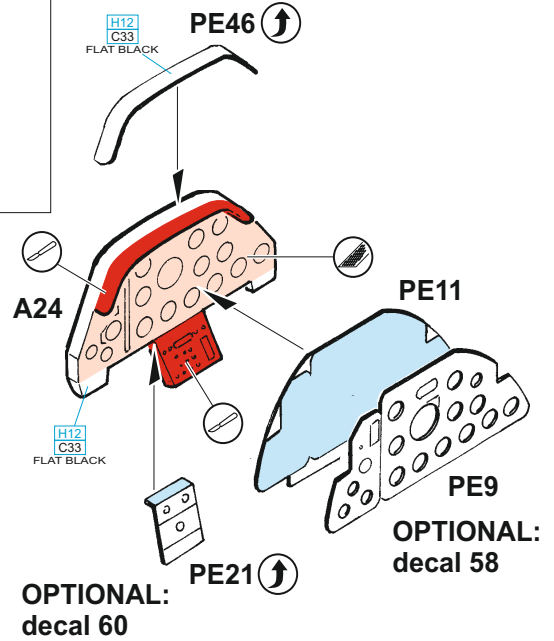
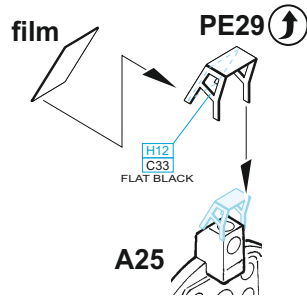
C**D**

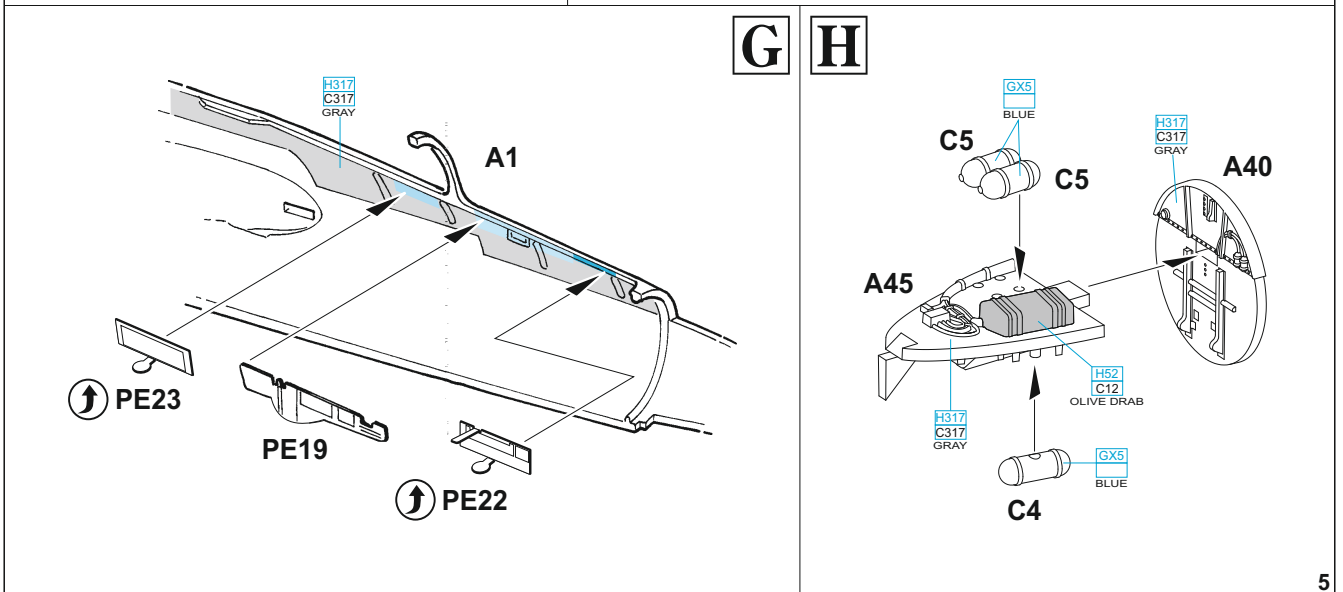
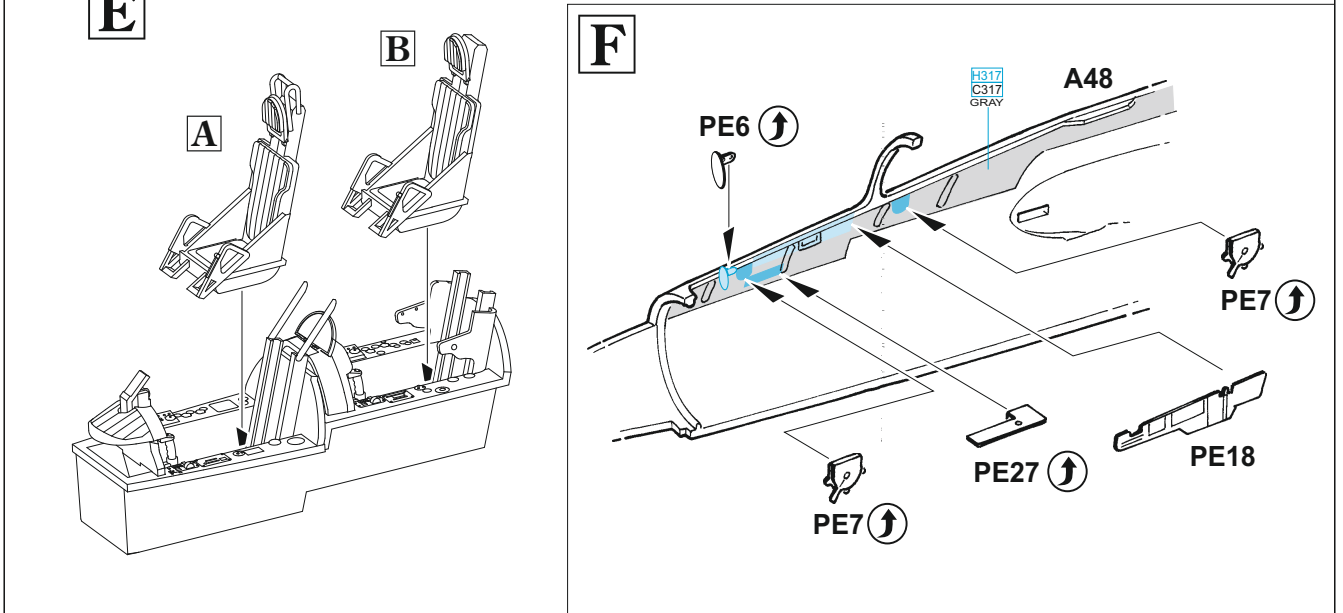
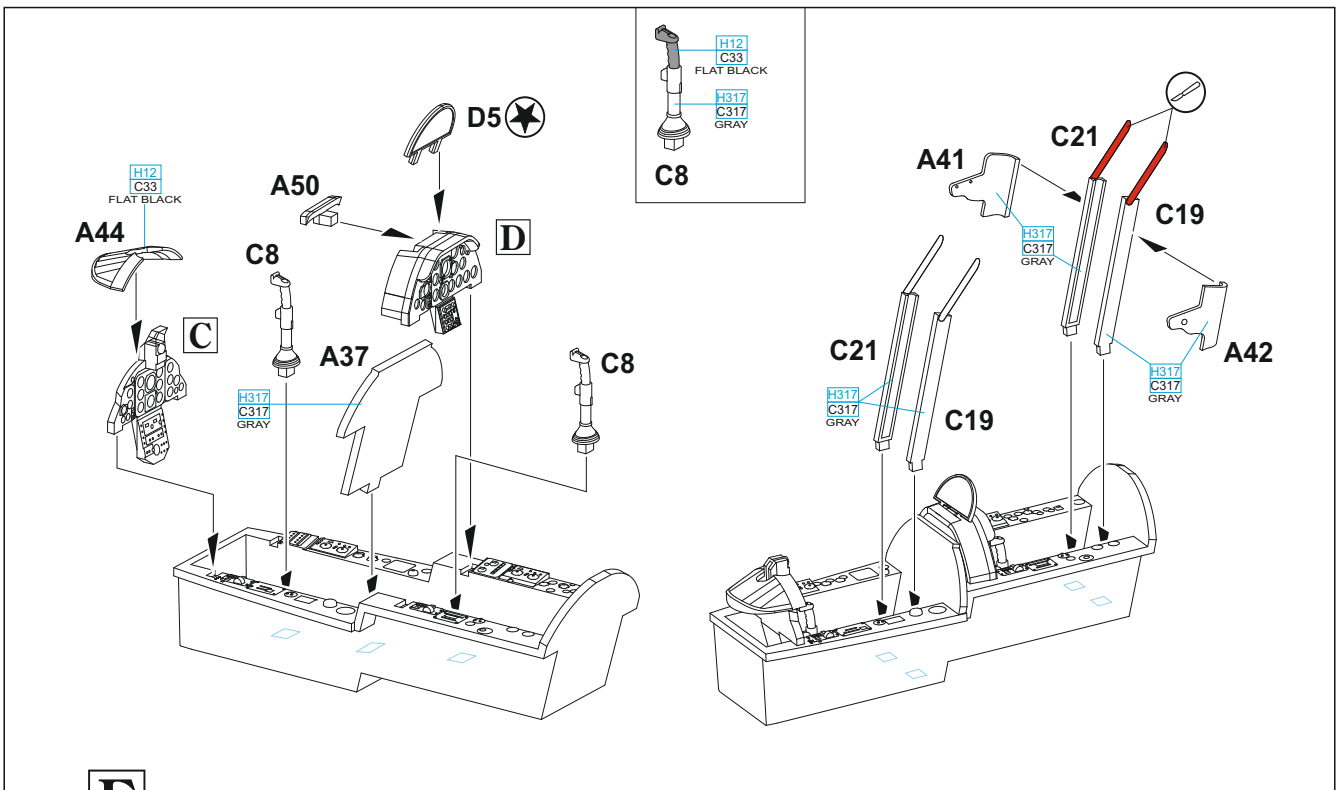

I

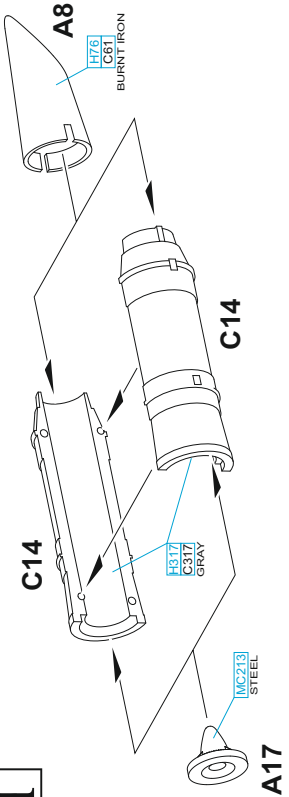

J

MARKING **D** ONLY

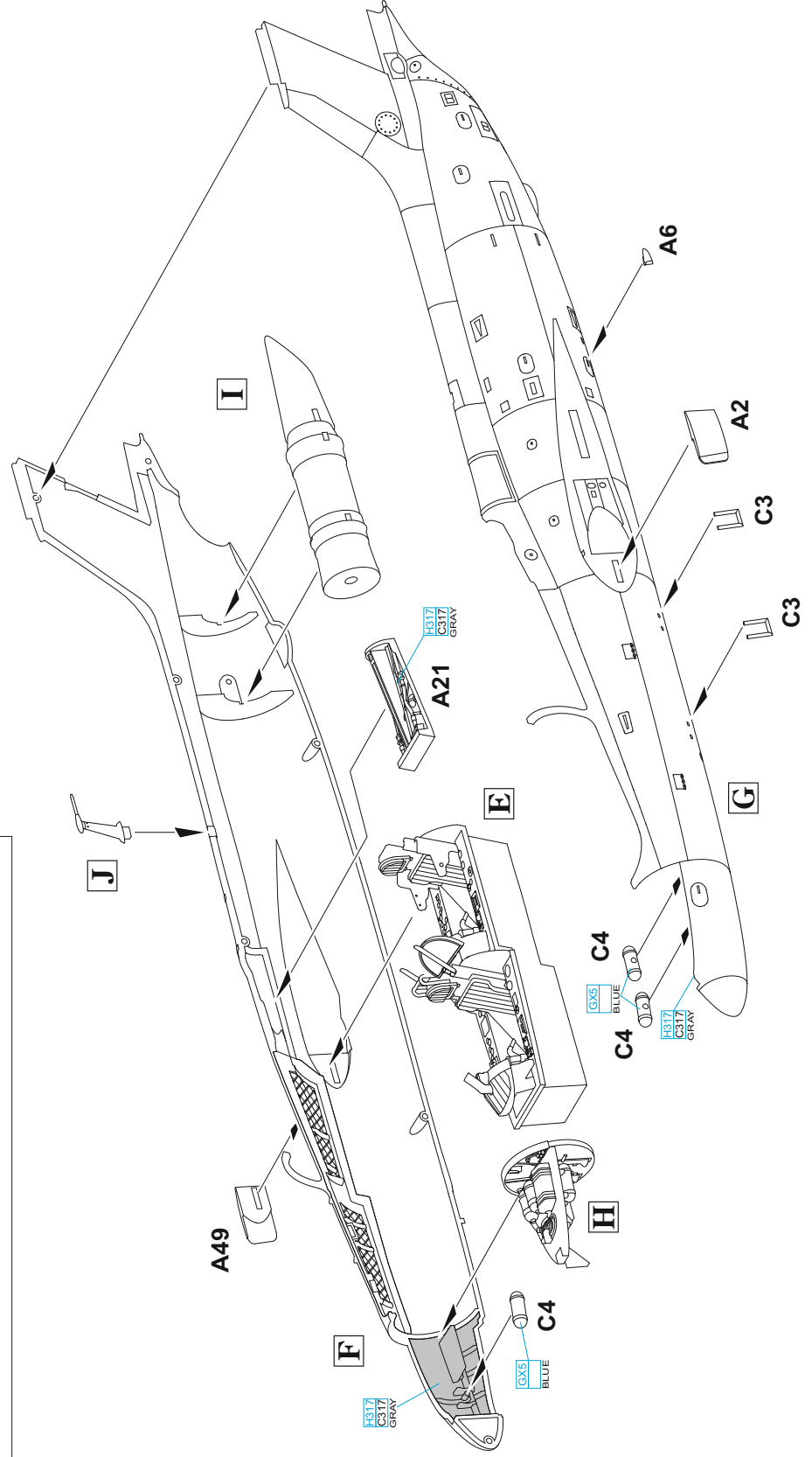
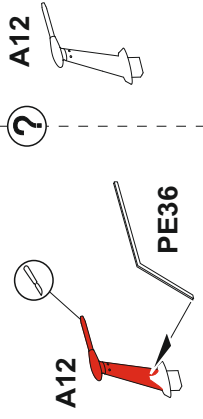

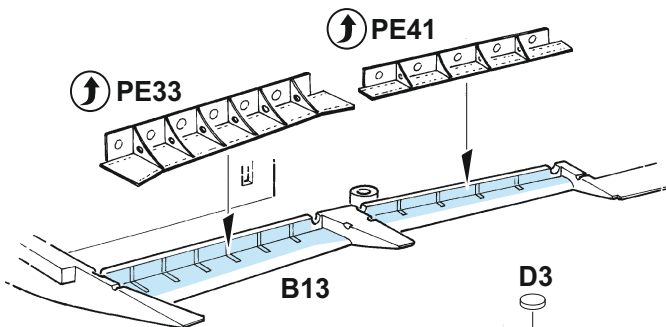
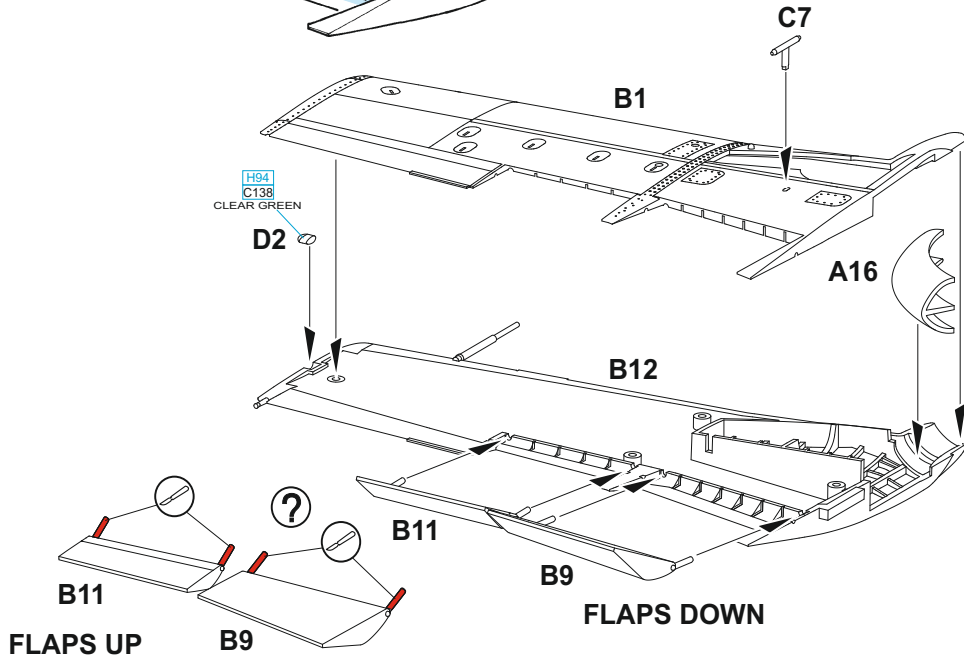
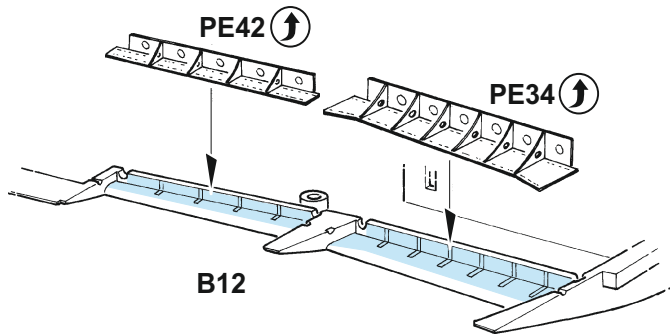

MARKINGS
A:B:C:D
ONLY

SM201 FINE SILVER

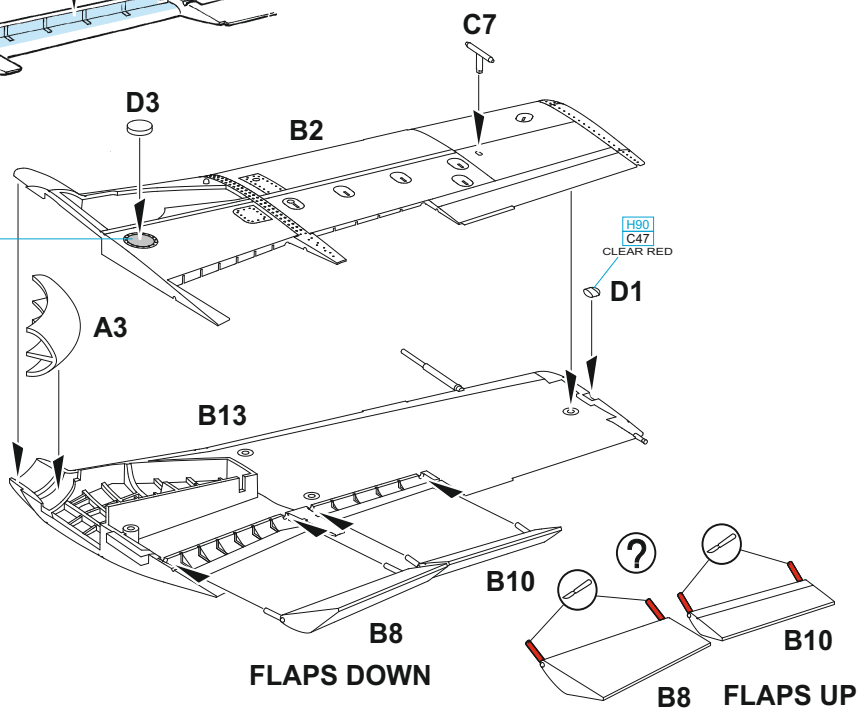

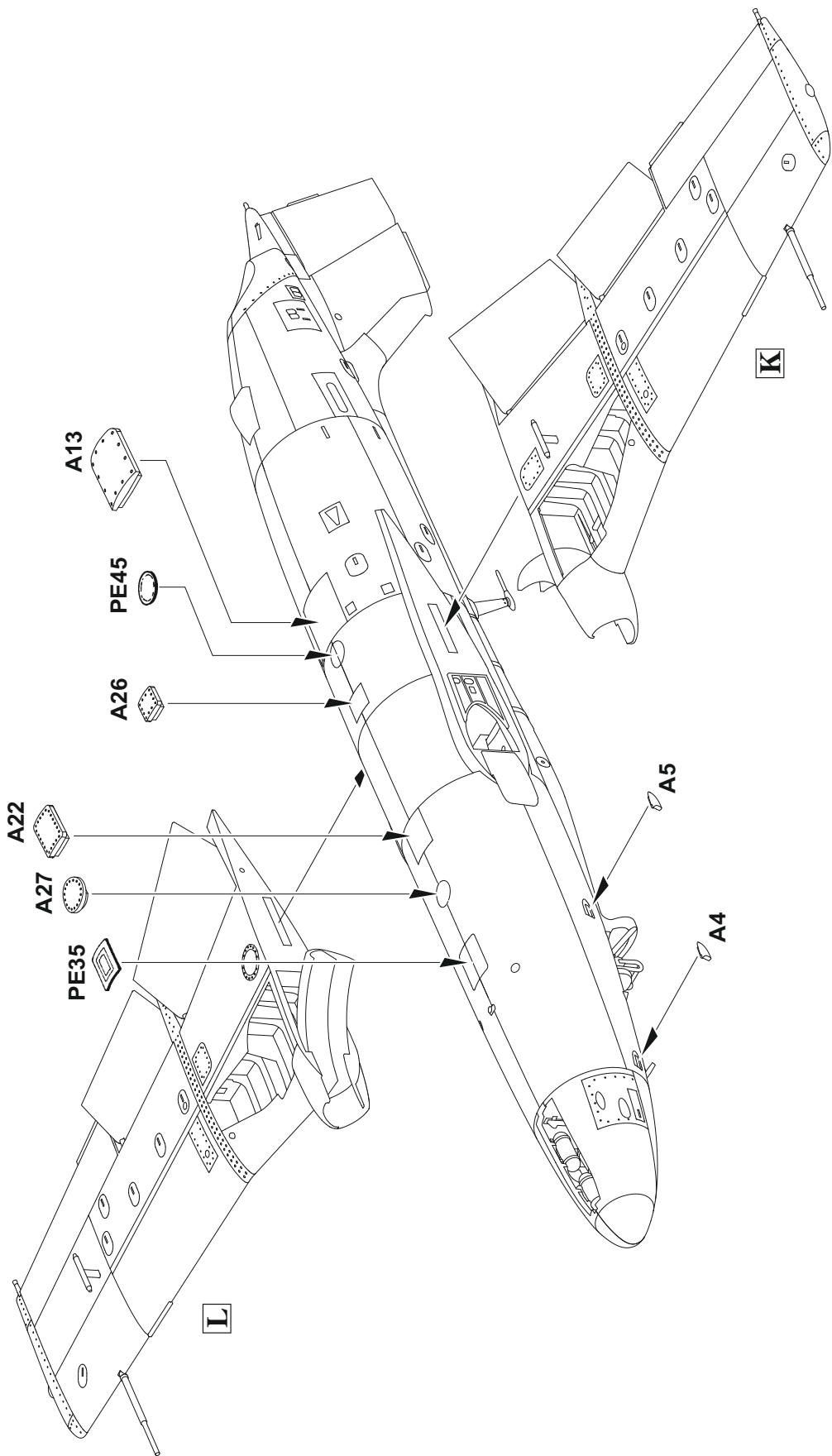

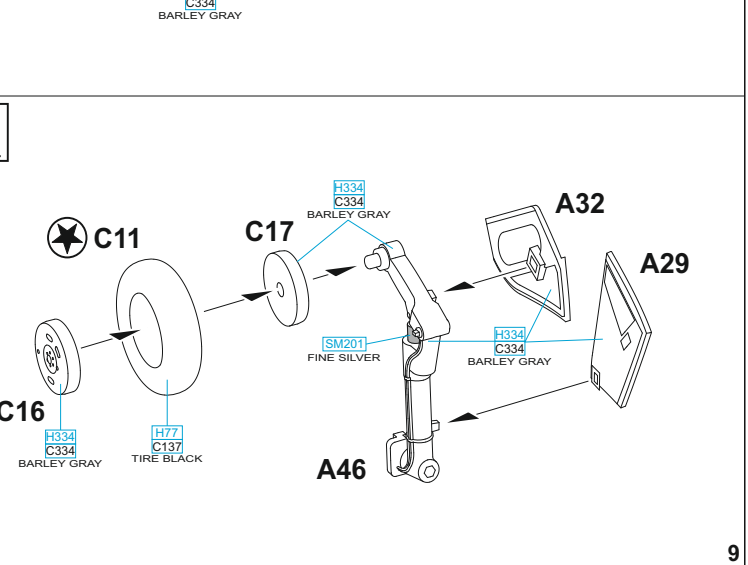
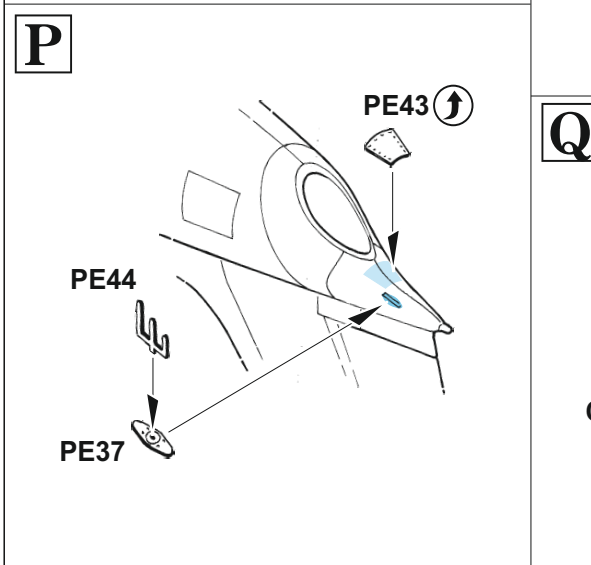
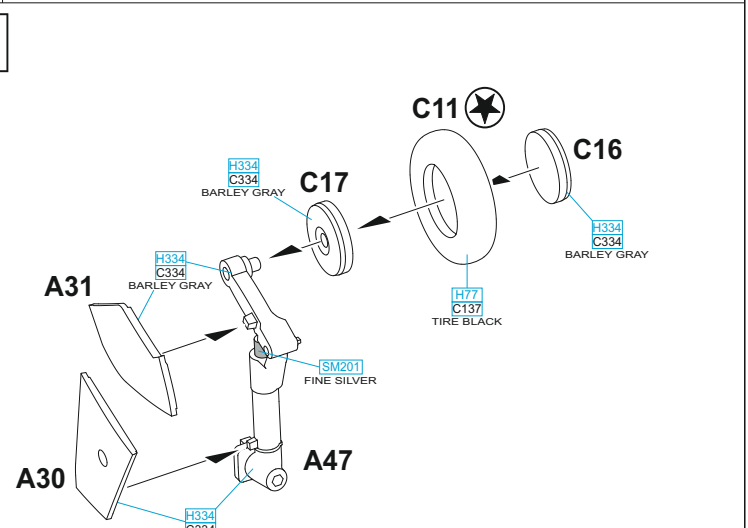
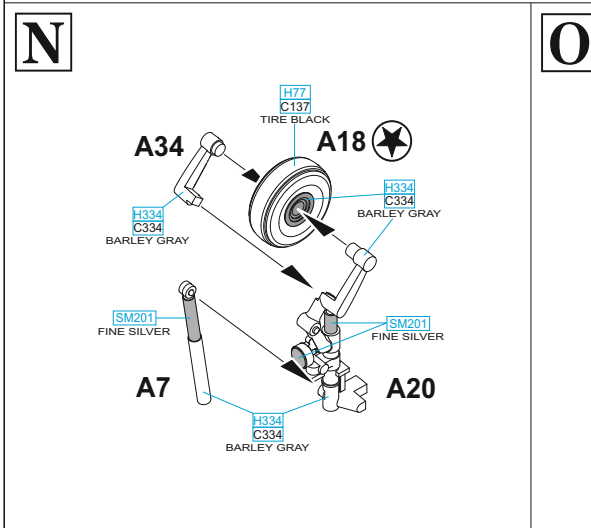
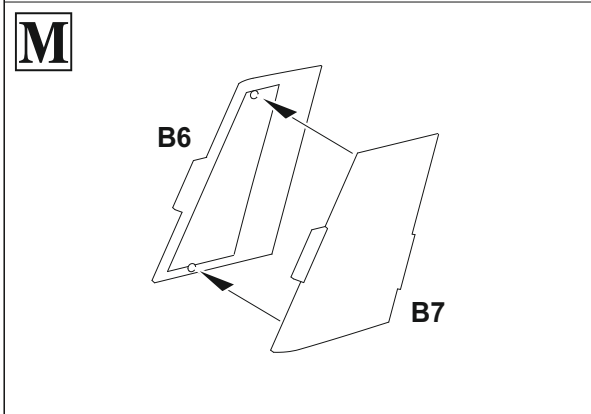
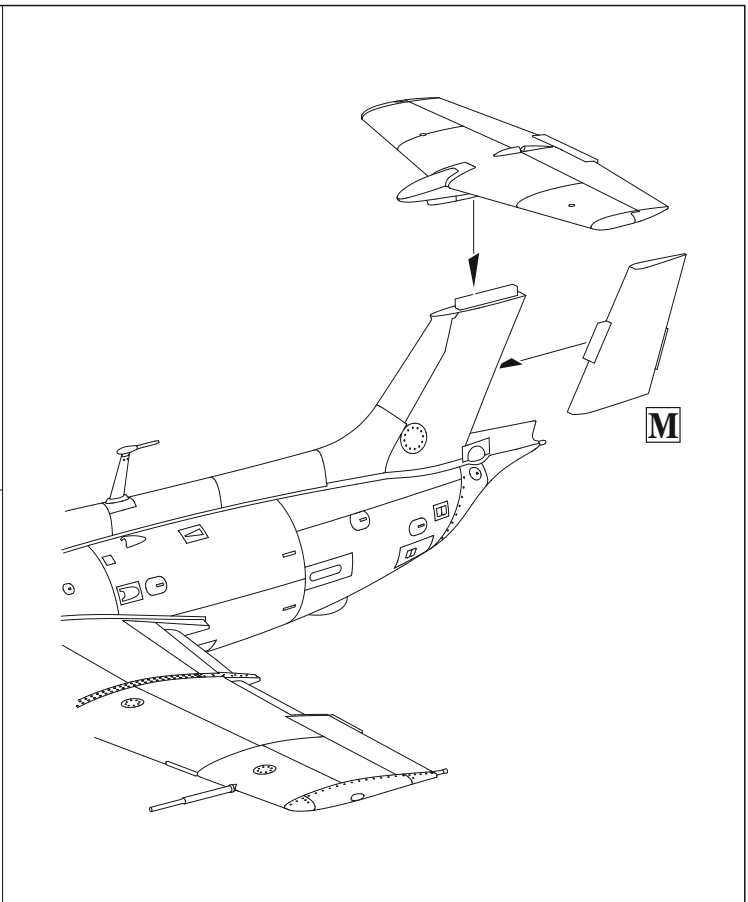
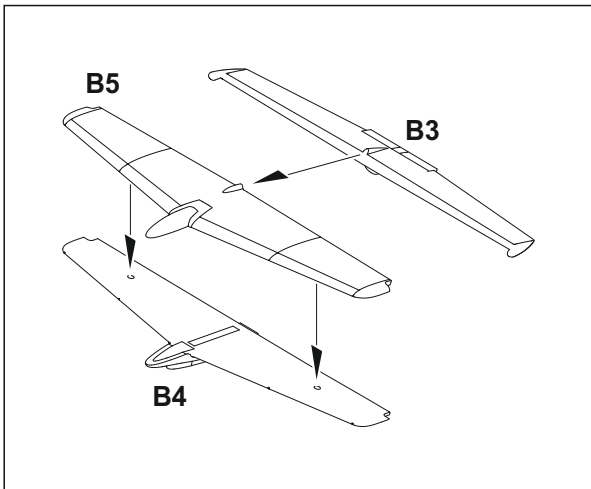

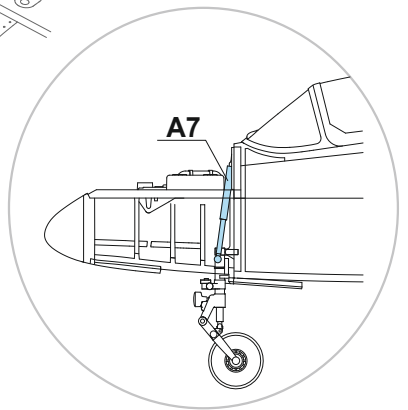
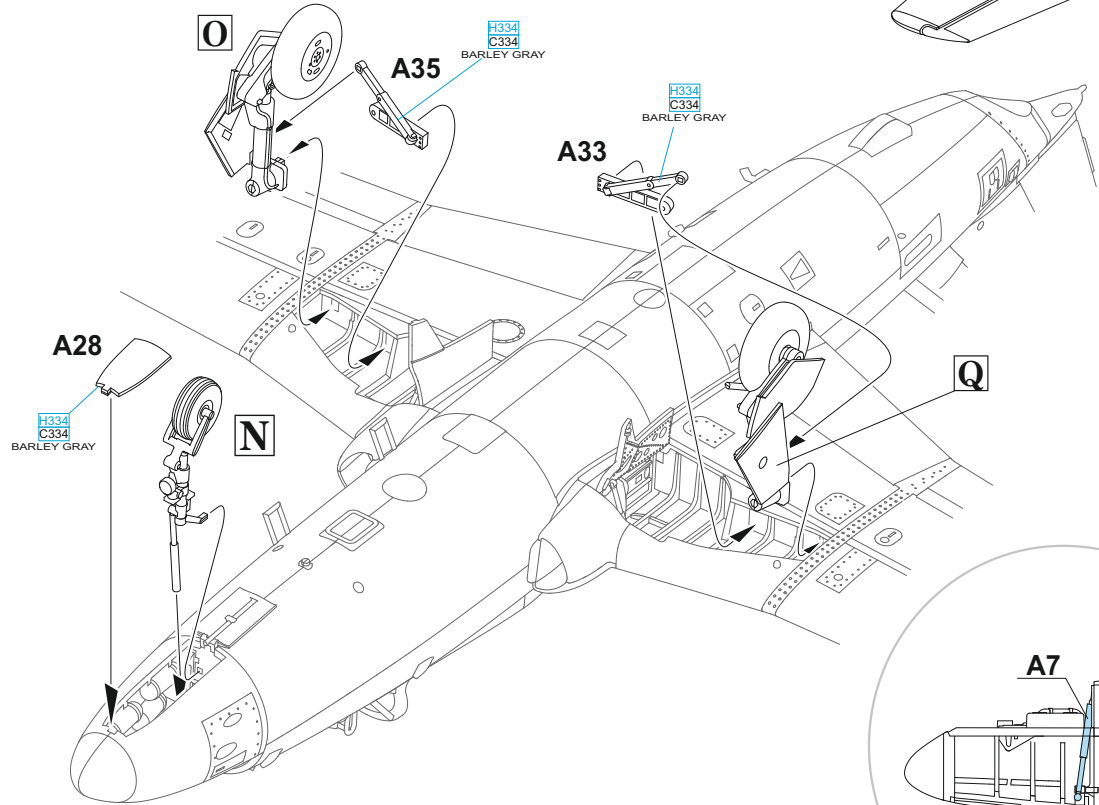
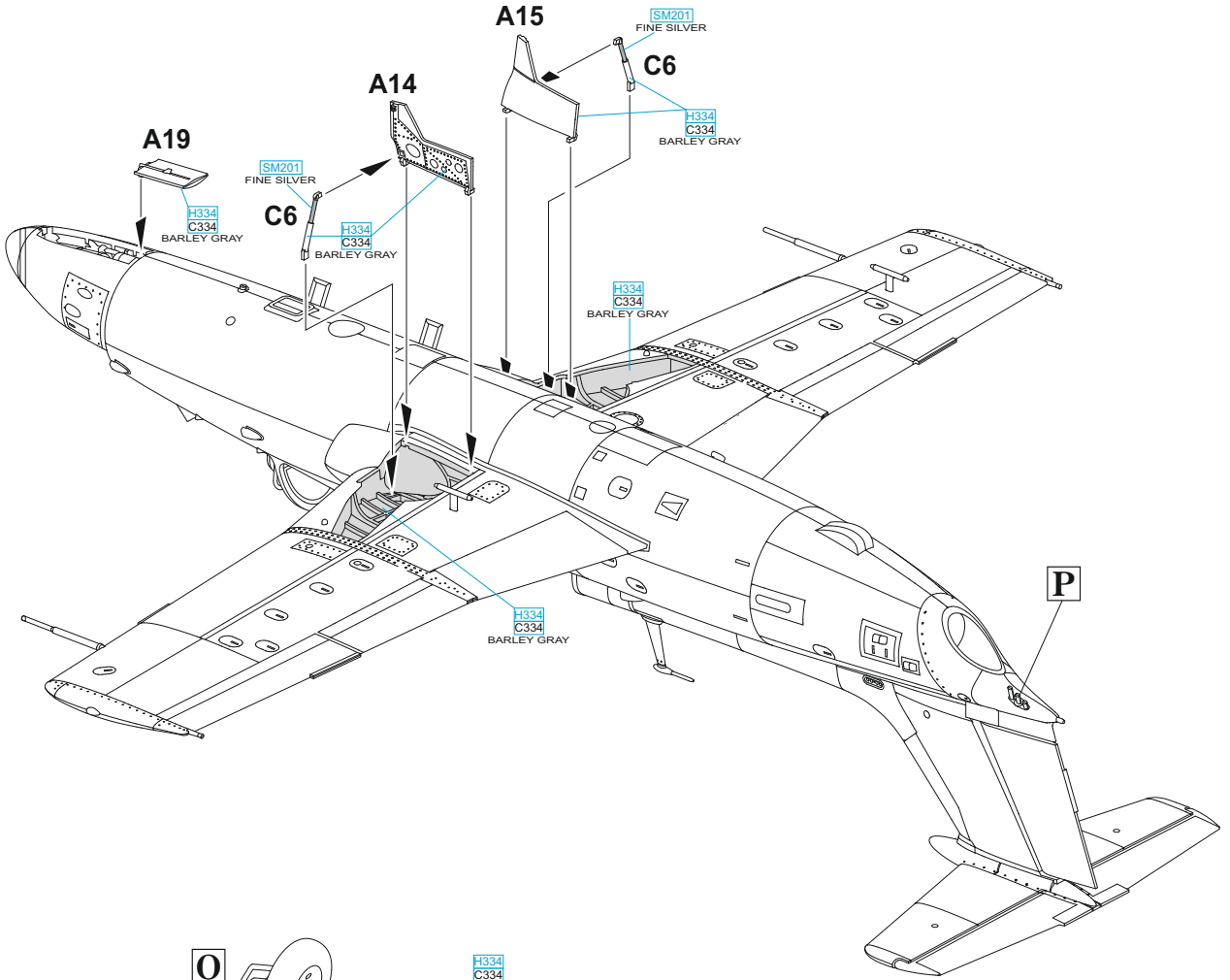

PE39

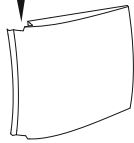

A9

PE38



C13

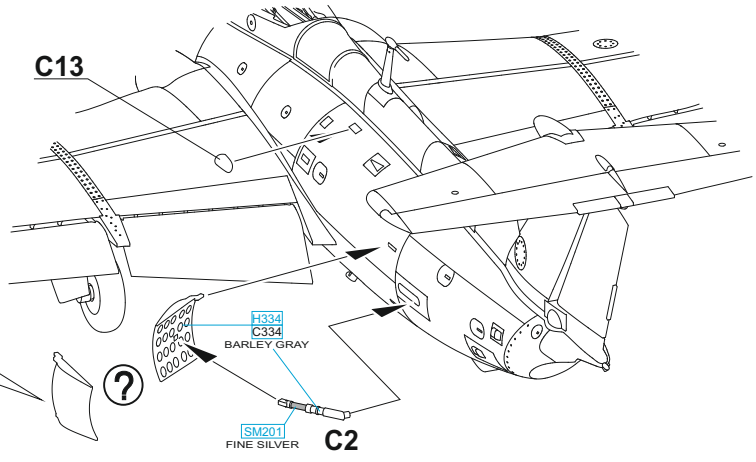

SM201
FINE SILVER

C2

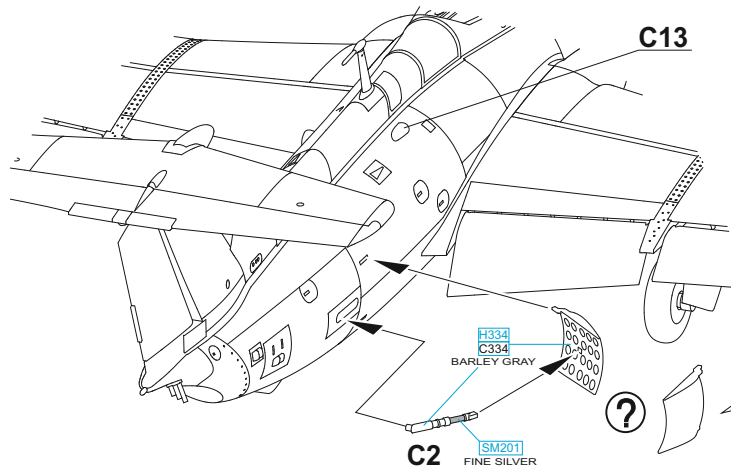

?

C2
SM201
FINE SILVER

PE39

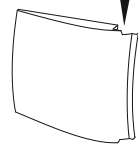

A10

PE38



2 pcs.

C20

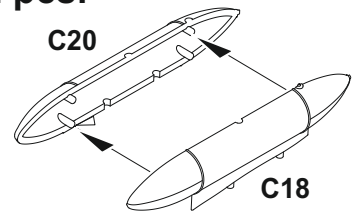

C18

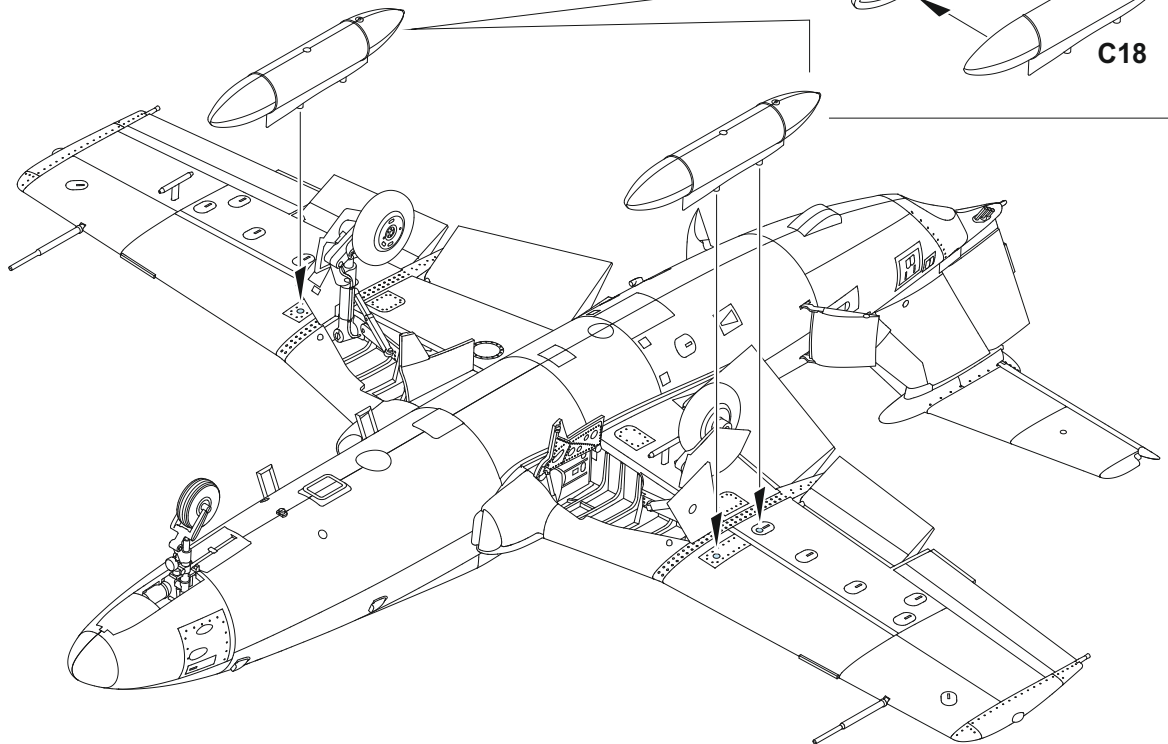

?

A23

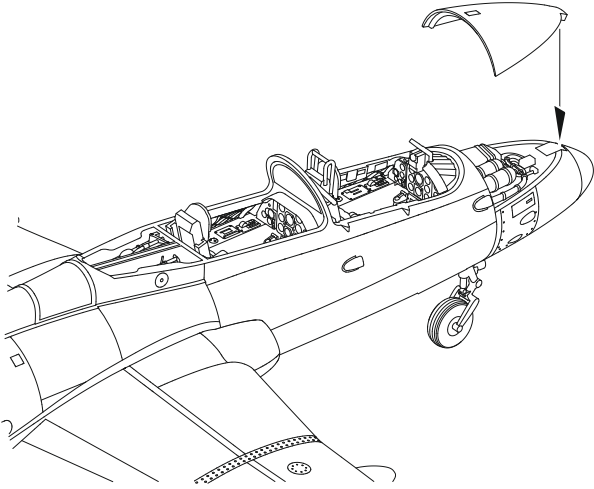

A36

H334
C334
BARLEY GRAY

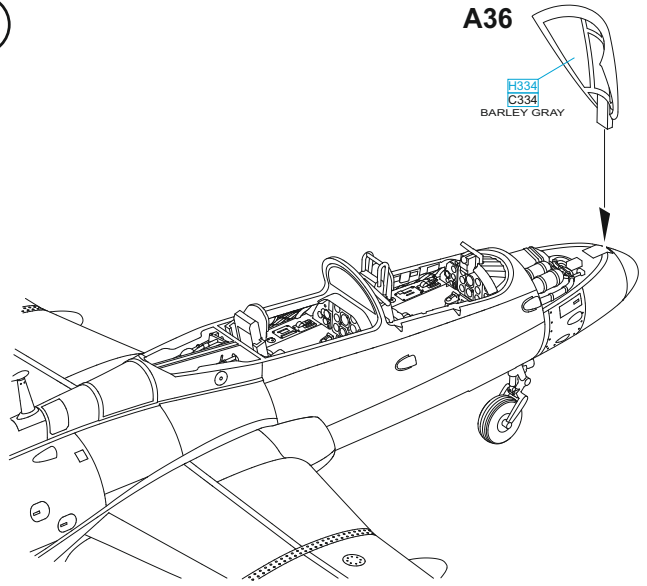

R

PE47

H317
C317
GRAY

D7

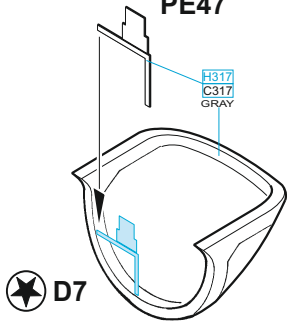

S

D6

H317
C317
GRAY

A43

H317
C317
GRAY

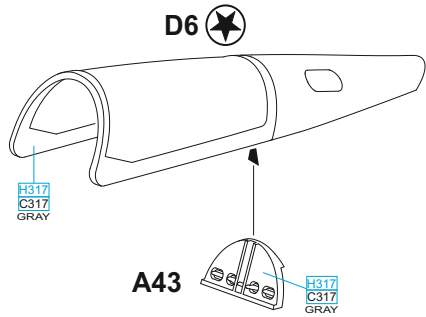

CLOSED CANOPY

S

D8

H317
C317
GRAY

R

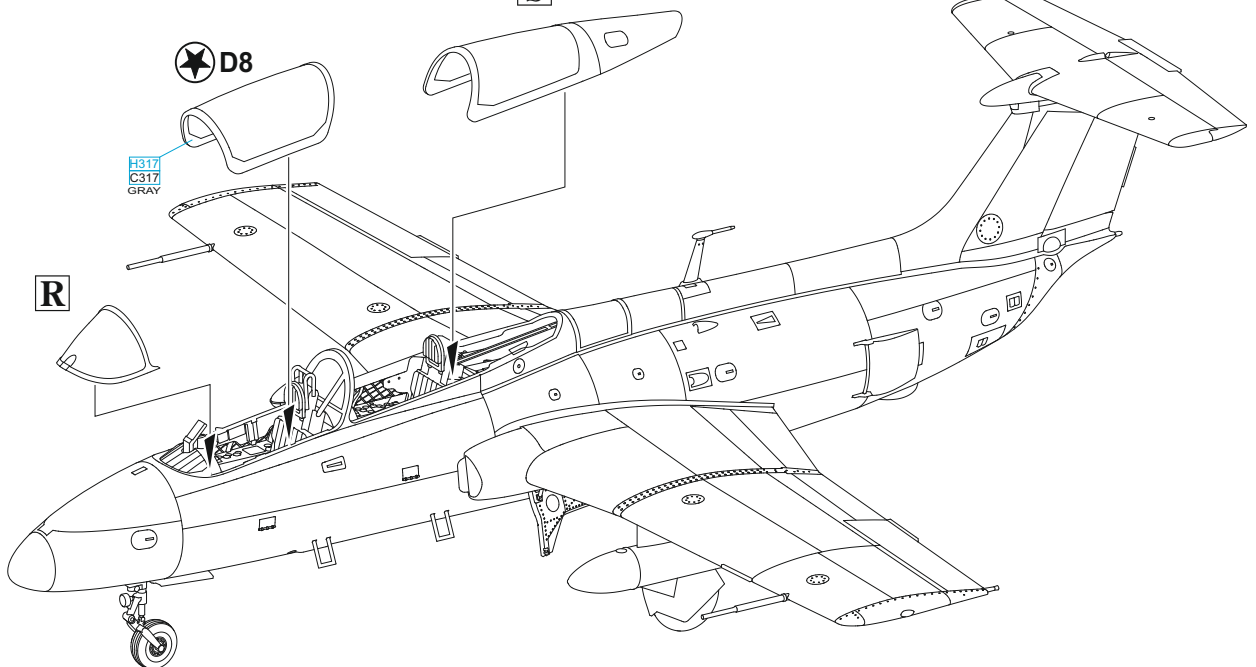

OPEN CANOPY

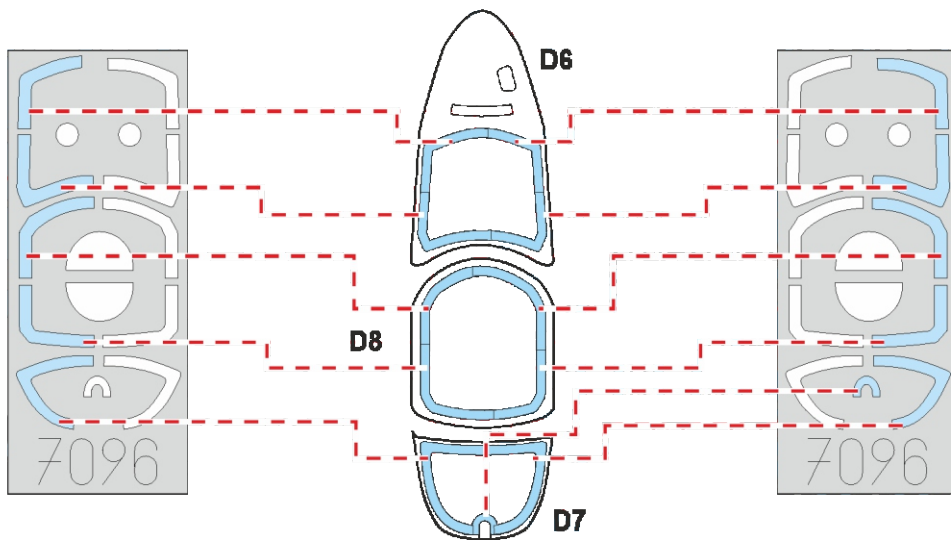
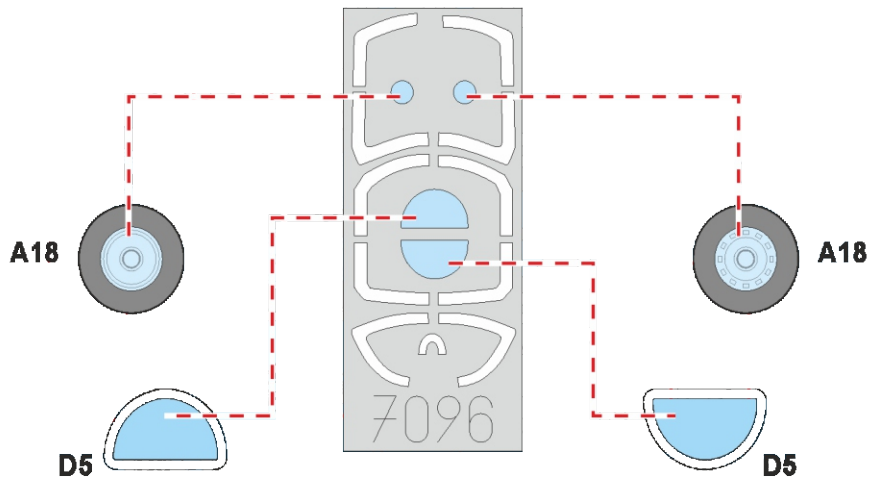
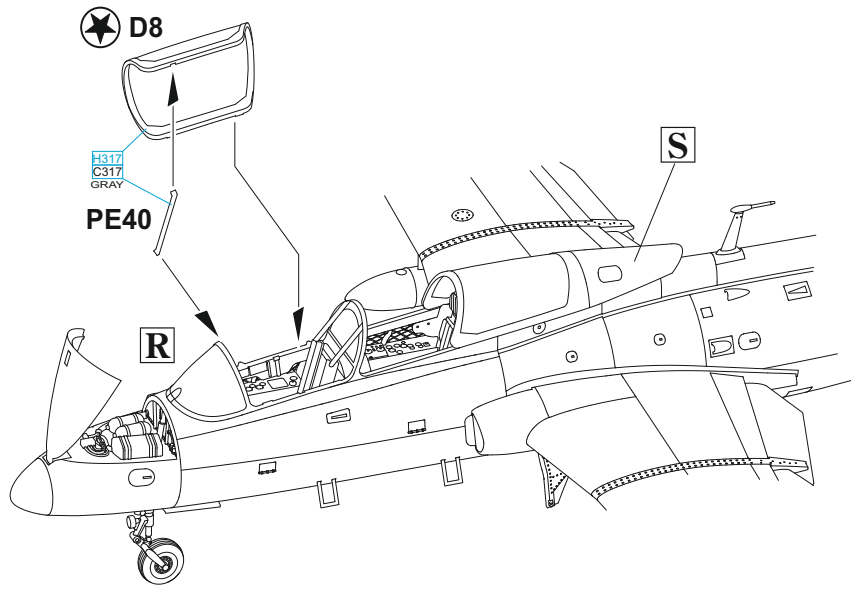

A 2853, 1st Flight, 11 Fighter Regiment, Žatec, Czech Republic, 1993

This Delfin received its striking coloring at the beginning of June 1993. It was created by the ground crew under the leadership of kpt. Ing. Karel Krejčí and it was introduced to the public on July 10 of the same year at an airshow in Žatec. After the disbandment of the 11 Fighter Regiment, the aircraft was transferred to the 1 Training Regiment at Přešov. The entire aircraft, including the drop tanks, was cleaned and degreased and the national insignia and fuselage number were covered by tape. After that, the aircraft was painted yellow, followed by the black tiger stripes.

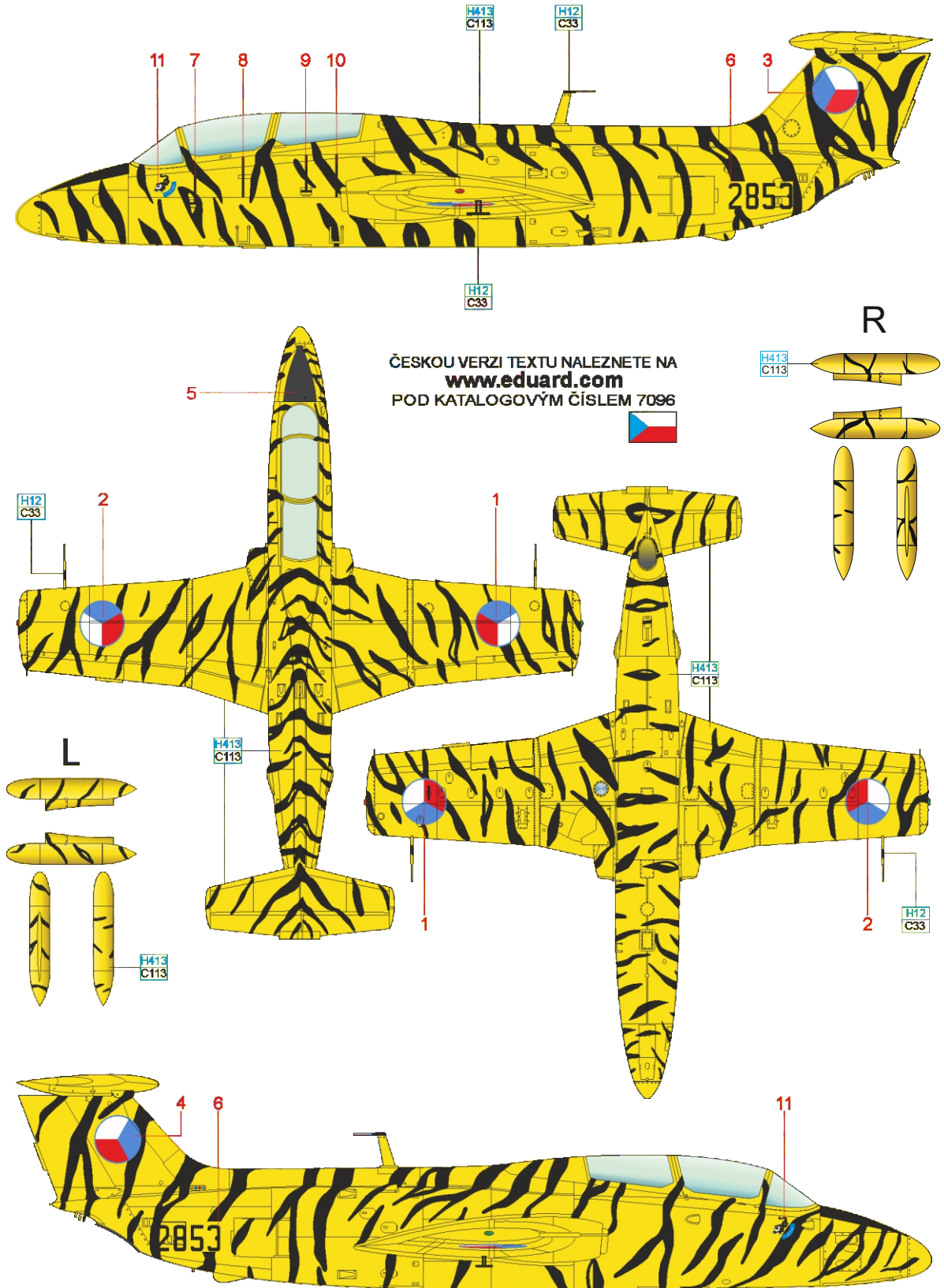

BLACK H12 C33 YELLOW H413 C113

eduard

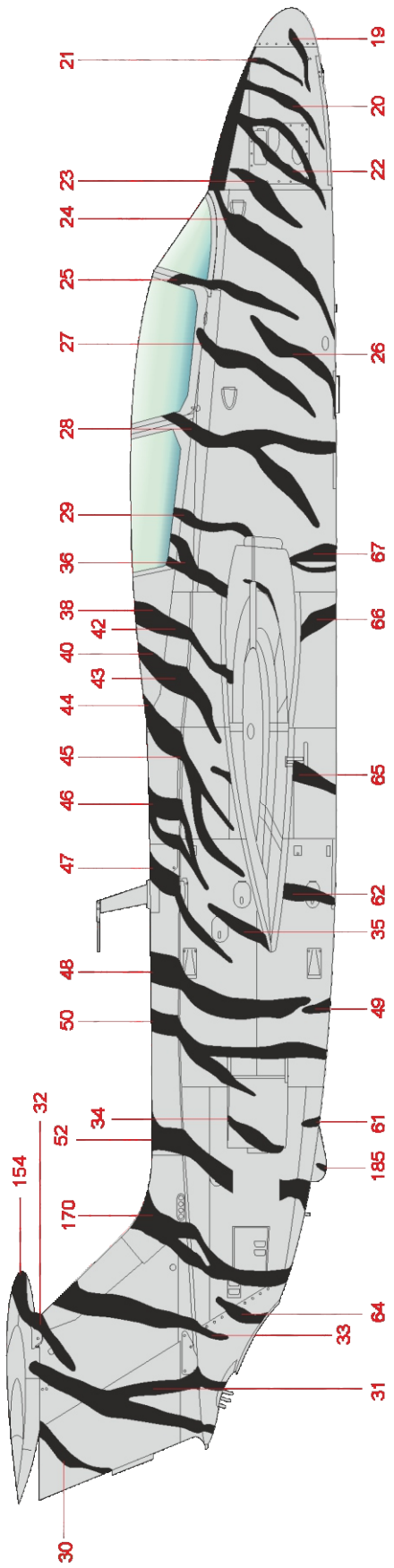
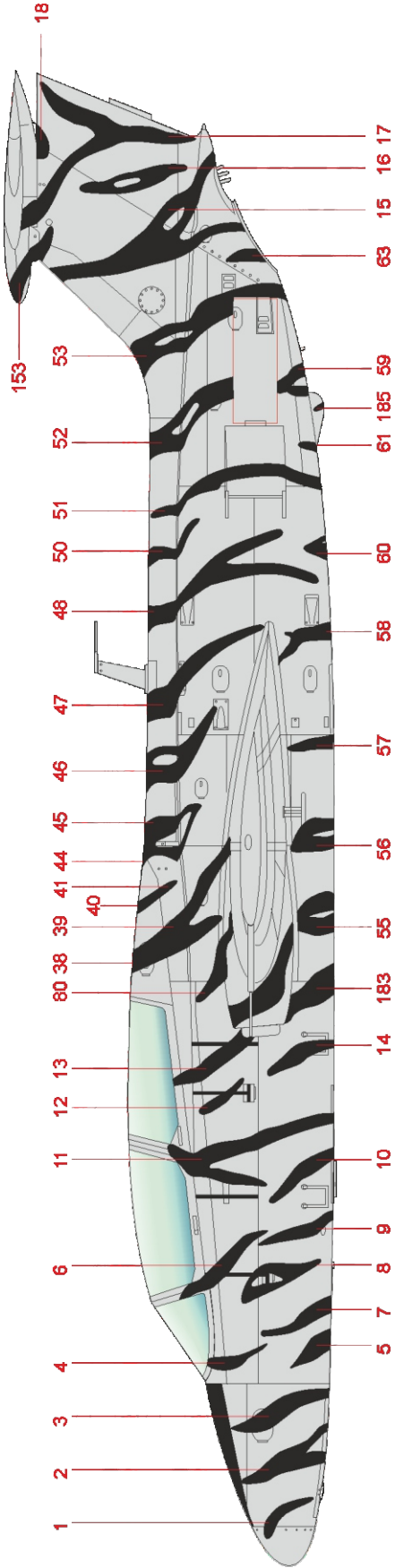

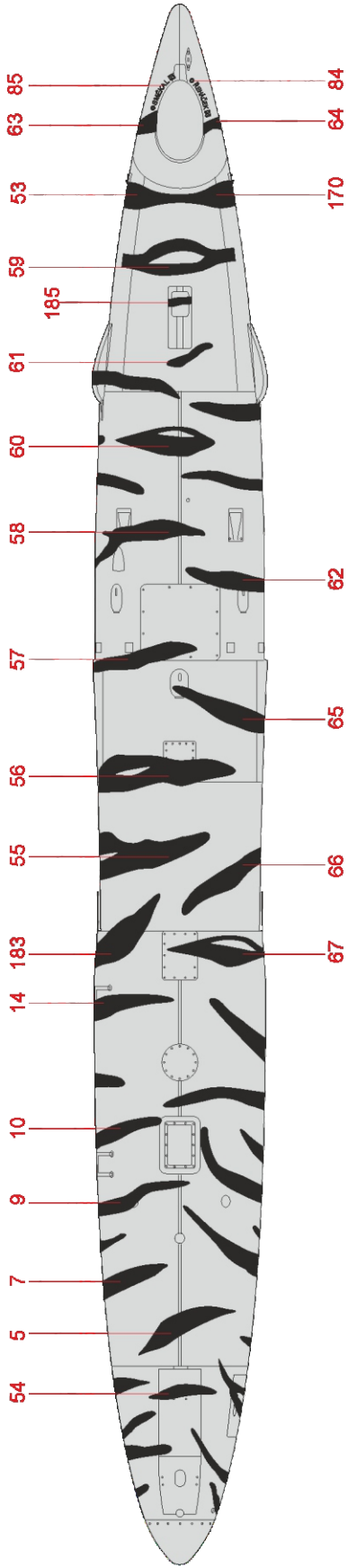

L

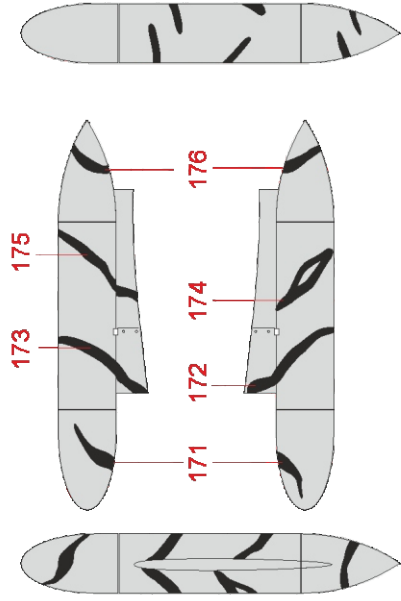

R

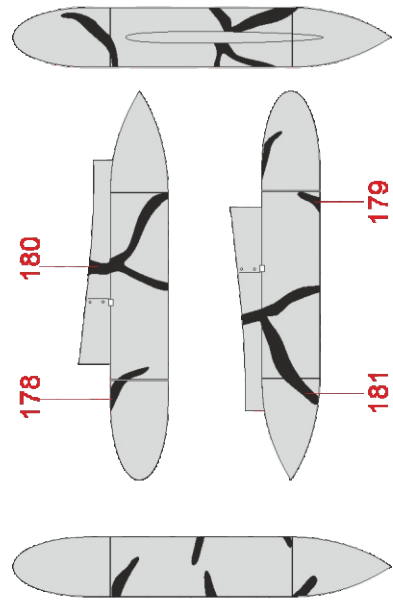

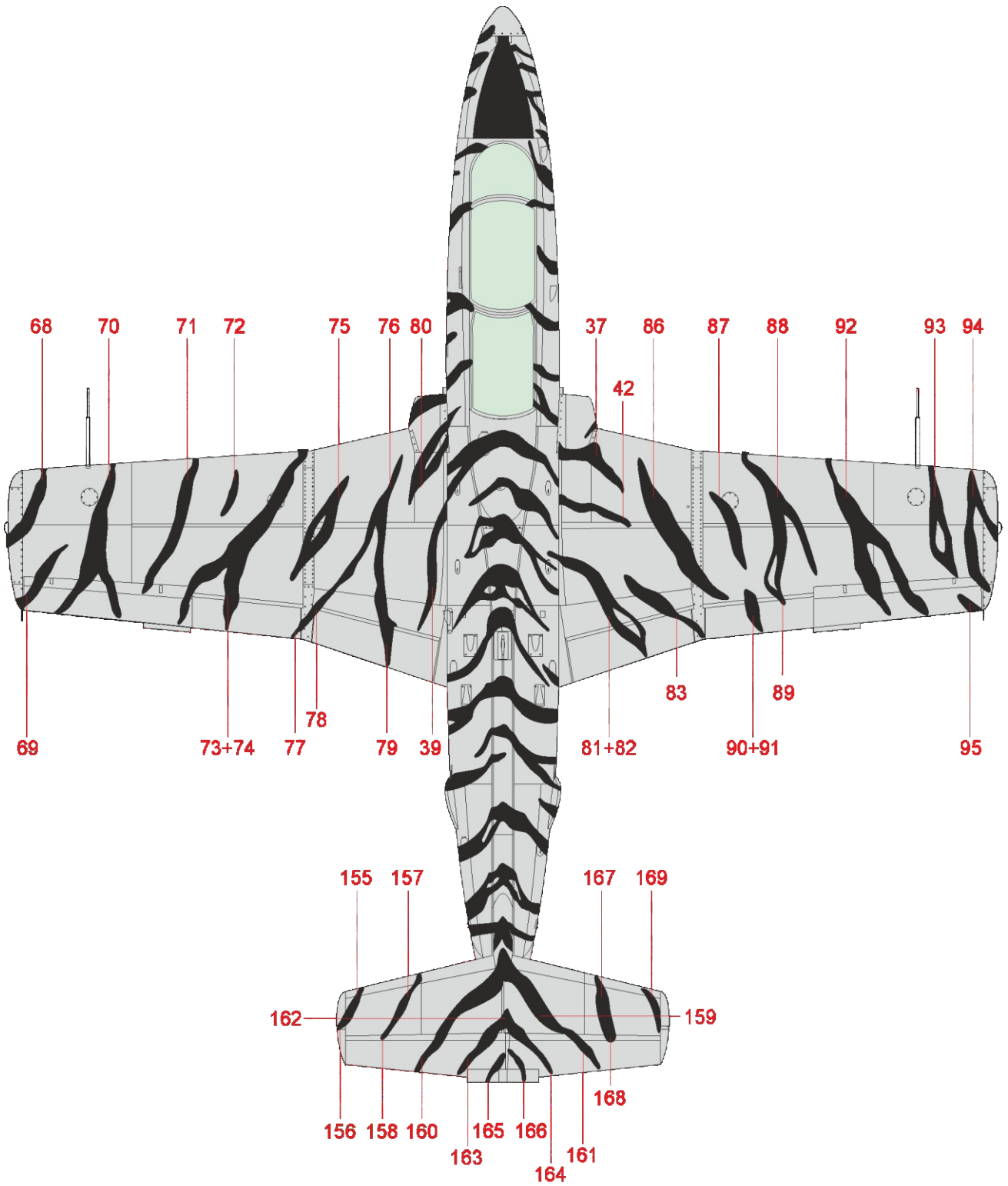

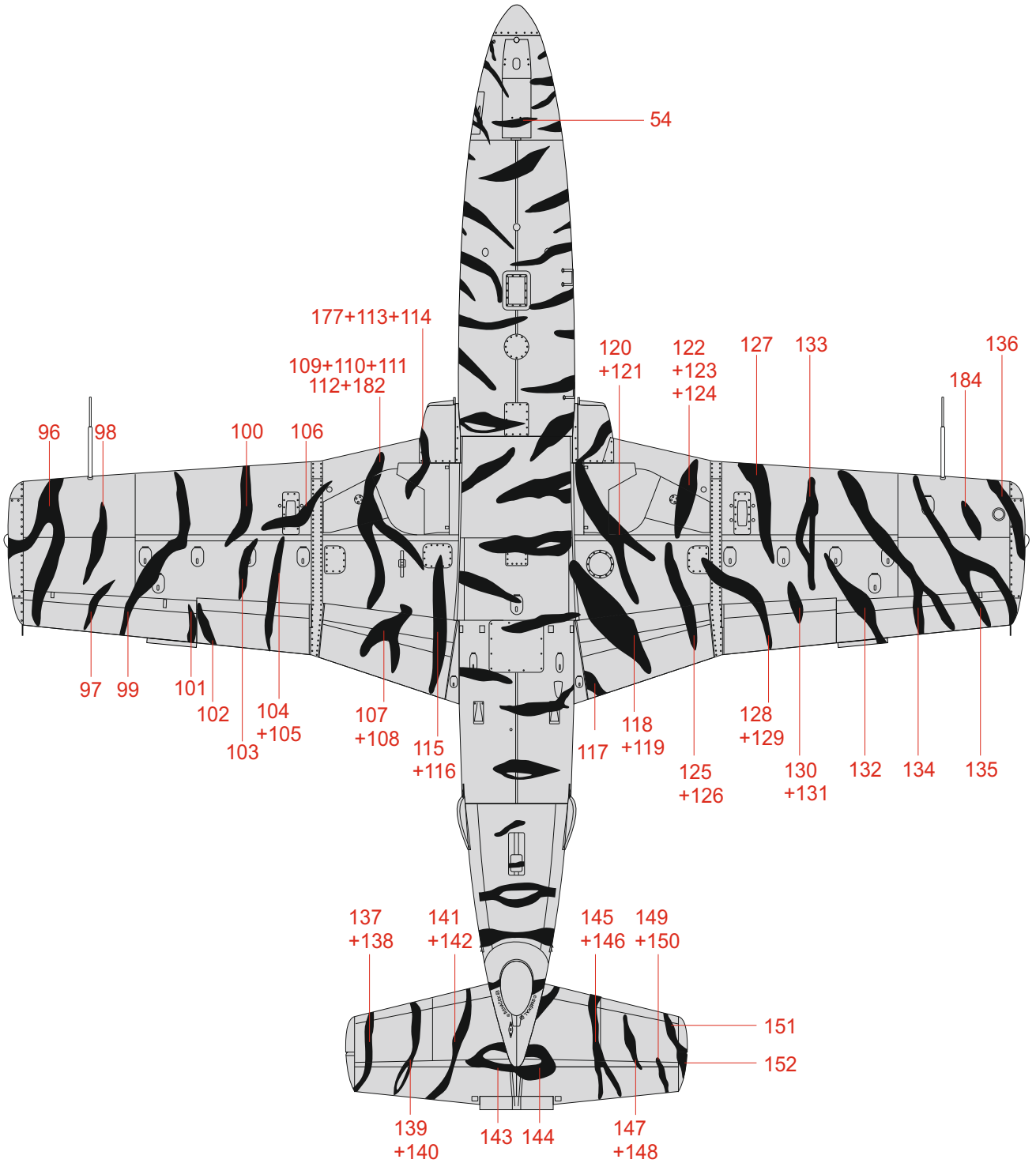

B 3250, International Fighter Pilots Academy, Košice, Slovak Republic, 1993

The International Fighter Pilot Academy was formed at the beginning of 1993 at Košice as an official training unit allowing civil clients to take part in aerial exercises on military aircraft, including helicopters. One of the aircraft that were used in this role and were also funded for in the budget of the Slovak Air Force, was this L-29. The fuselage of this Delfin was painted grey, while the wings received a striking scheme consisting of red, white and blue segments reminiscent of past aerobatic schemes. The IFPA badge was carried under the windscreen on both sides of the aircraft.

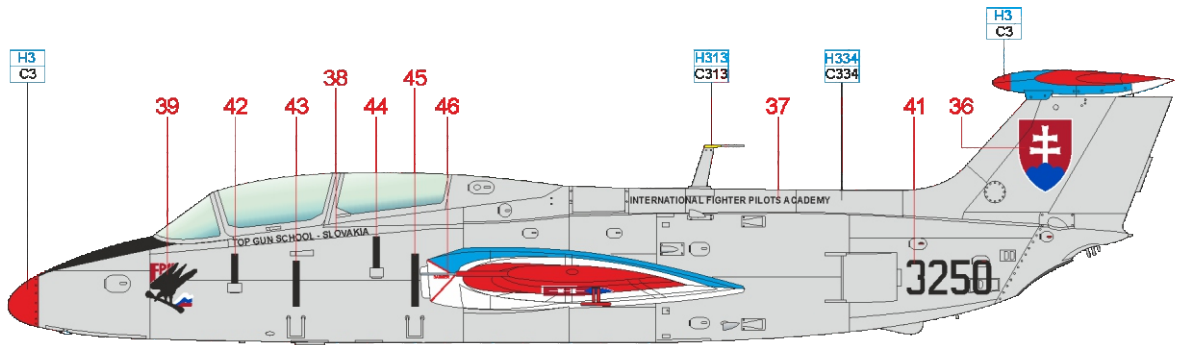

ČESKOU VERZI TEXTU NALEZNETE NA
www.eduard.com
 POD KATALOGOVÝM ČÍSLEM 7096

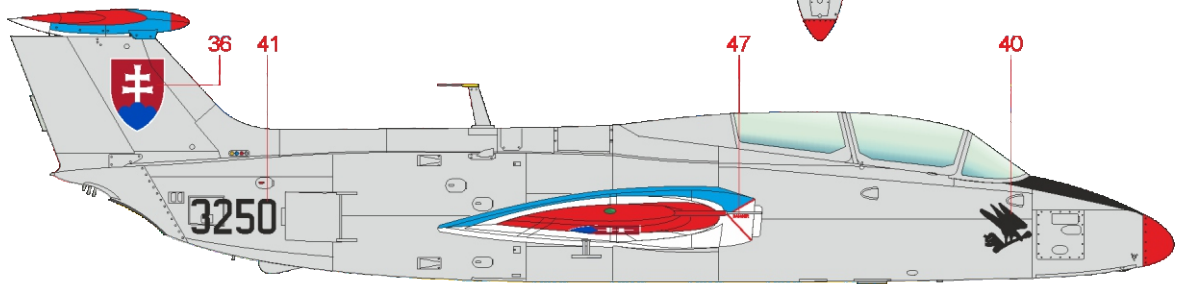
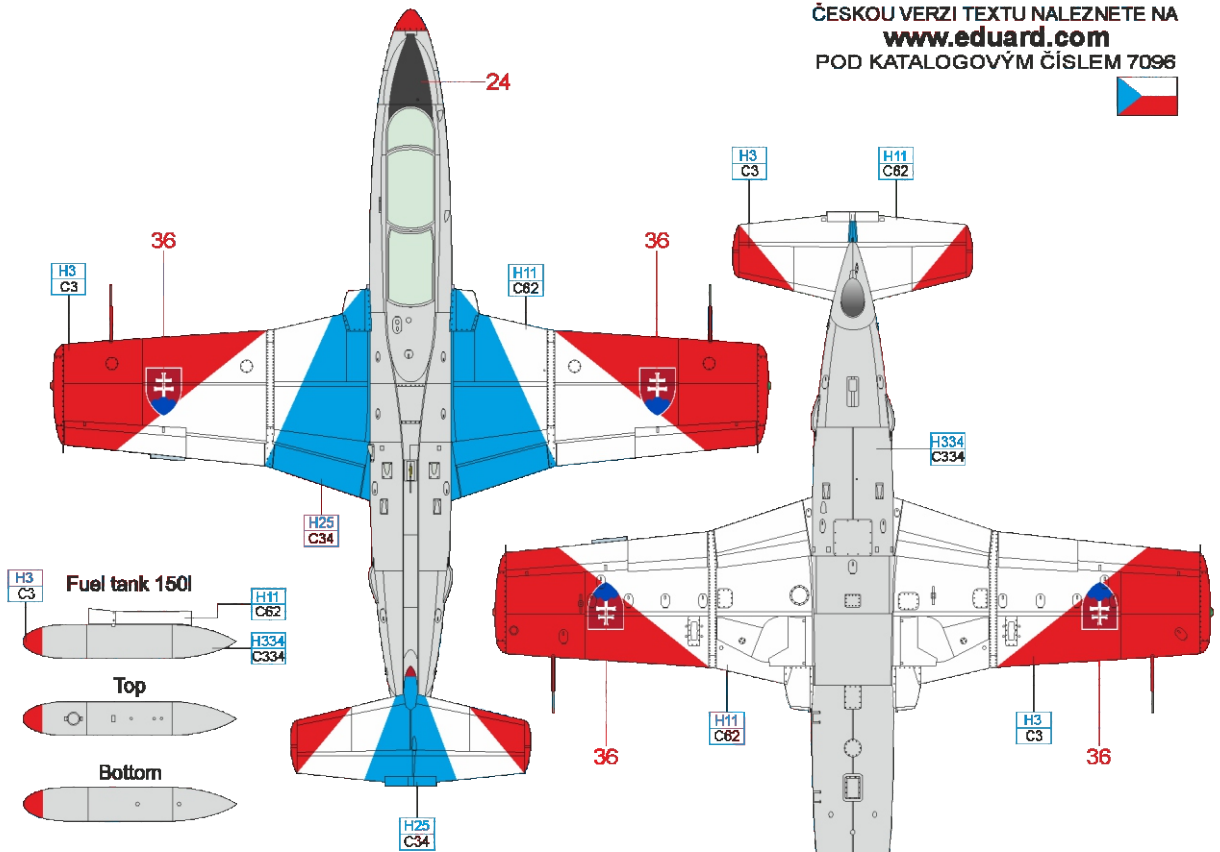

BARLEY GRAY	H334 C334	RED	H3 C3	SKY BLUE	H25 C34	WHITE	H11 C62	YELLOW	H313 C313
-------------	-----------	-----	-------	----------	---------	-------	---------	--------	-----------

C 101 Fighter Reconnaissance Wing, Szolnok Air Base, Hungary, Summer 1978

The L-29 factory number 591378 was built in 1965 and delivered to Hungarian AF to serve at Szolnok Air Force Base with 101 Fighter Reconnaissance Wing. In the first part of its active life the aircraft flew in natural metal colors with Red 378 board number. The aircraft returned twice to Czechoslovakia for overhaul in the Trenčín factory, in 1971 and 1978. After the second overhaul it received a new camouflage scheme represented here. These are Czech colors which were very different from Hungarian AF official coloring. Later several new patches of dark green were added by Hungarian technicians as repairs. It is interesting that this aircraft is still in service but this time in private hand in USA as N21KE. After withdrawal from Hungarian AF in March 1983 it was sold in summer of 1984 and had a colorful after-life, flying in VVS colors as 09 with red star. With breakup of the Soviet Union, it received YL-PAD registration to be shipped eventually to Scotland in mid 1990s and kept in open storage for many years. It was sold again and shipped to the US, after refurbishment flew as Red 09 from Minnetonka.

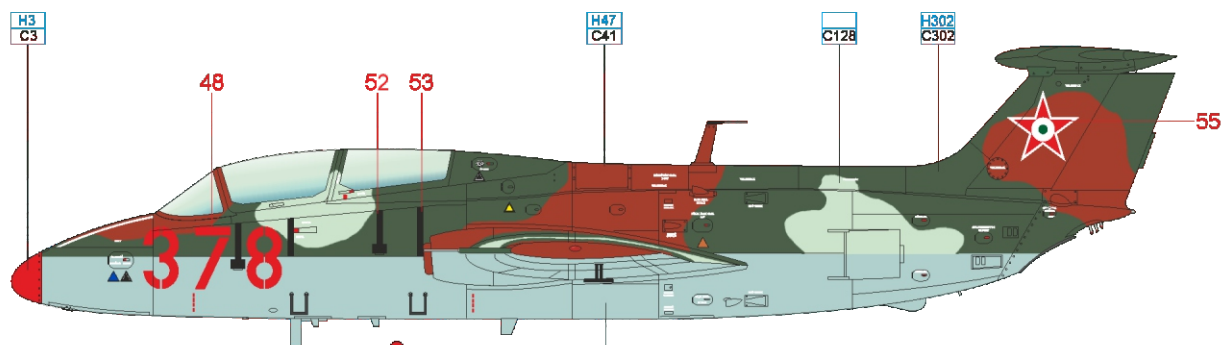

ČESKOU VERZI TEXTU NALEZNETE NA
www.eduard.com
 POD KATALOGOVÝM ČÍSLEM 7096

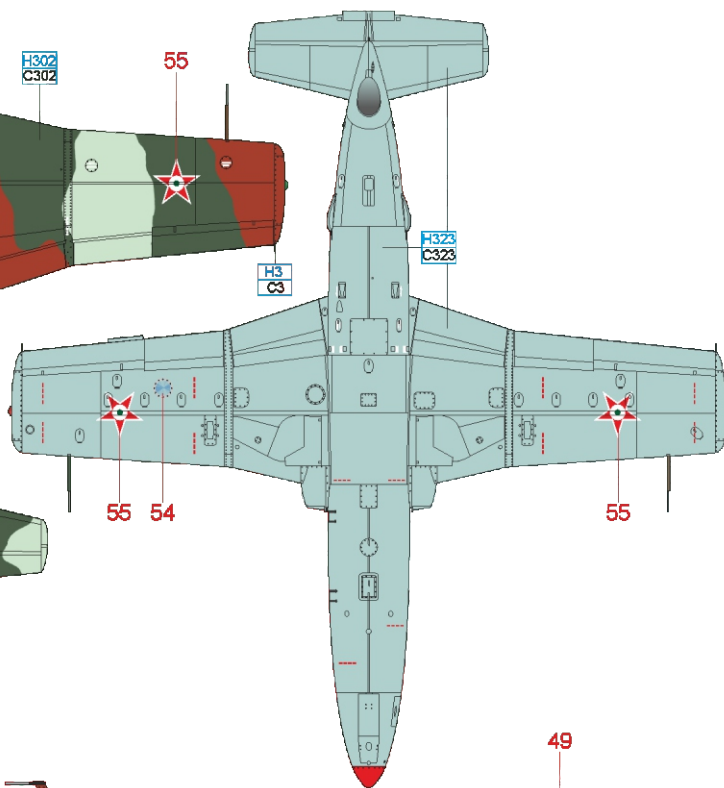
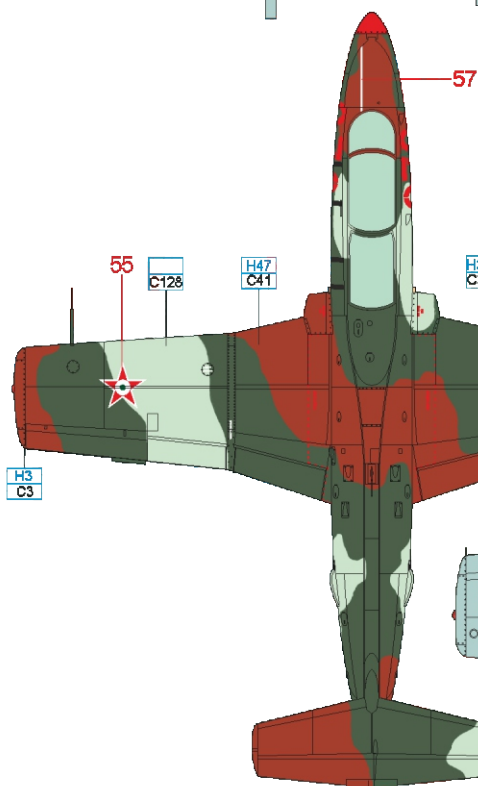

Researched by Gabor Szekeres

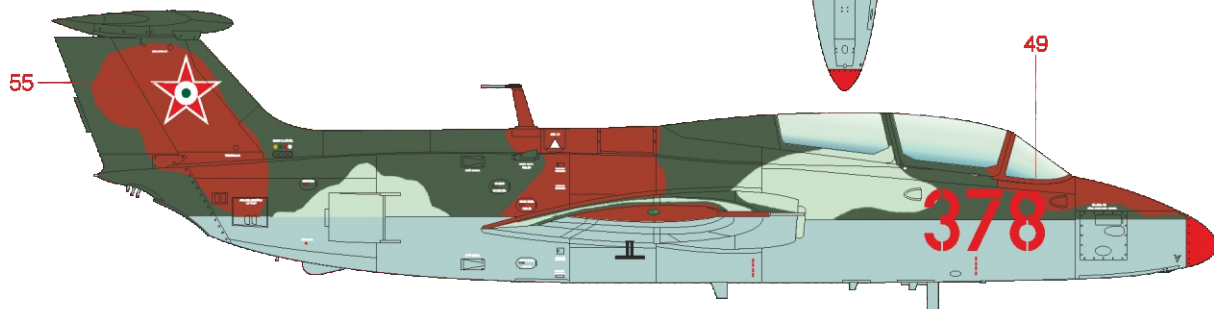

LIGHT BLUE	H323	GRAY	H47	GREEN	H302	RED	H3
BLUE	C323	GREEN	C128	BROWN	C41	BROWN	C3

D Reno AFB, United States of America, 2009

The American company Tactical Air Services owns two L-29 Delfins and these are used to train army and navy elements by simulating incoming anti-shipping or air-to-surface rounds. During RIMPAC 2010 (Rim Of The Pacific – the largest international naval exercise) they were photographed on the deck of LHD-6 Bon Homme Richard. Aircraft N179EP is camouflaged similarly to the aircraft operated by the Russian Air Force, including Russian stars on the wings and fin.

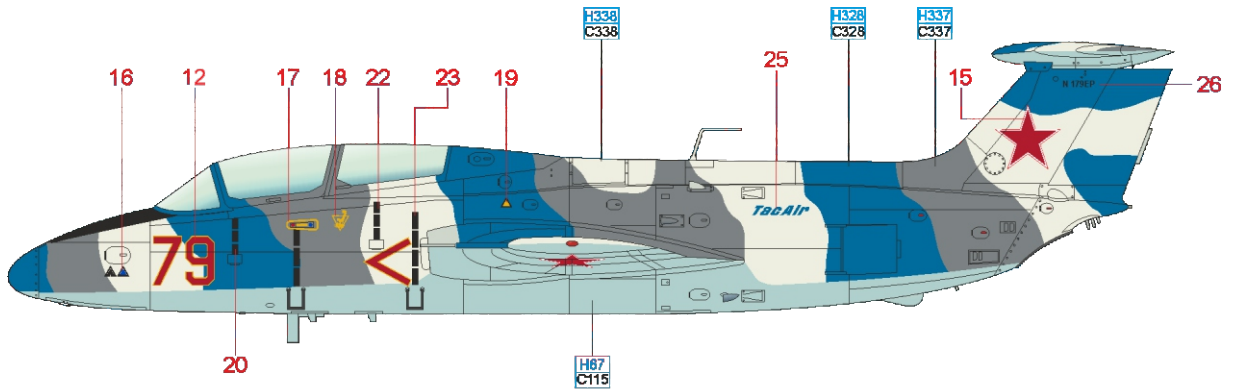

ČESKOU VERZI TEXTU NALEZNETE NA
www.eduard.com
 POD KATALOGOVÝM ČÍSLEM 7096

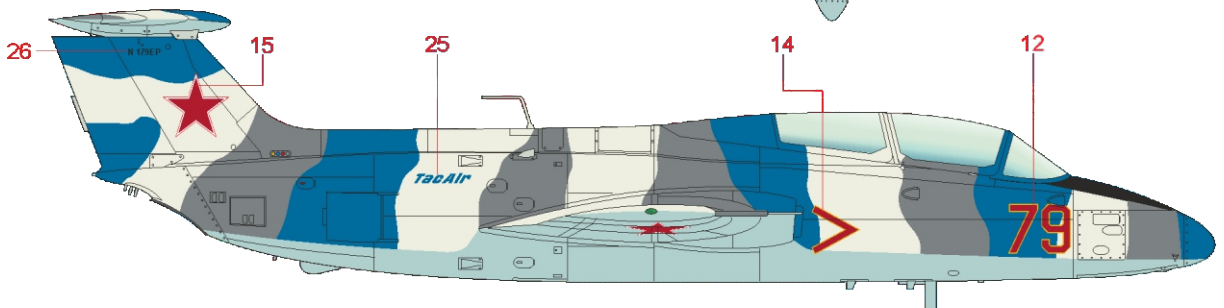
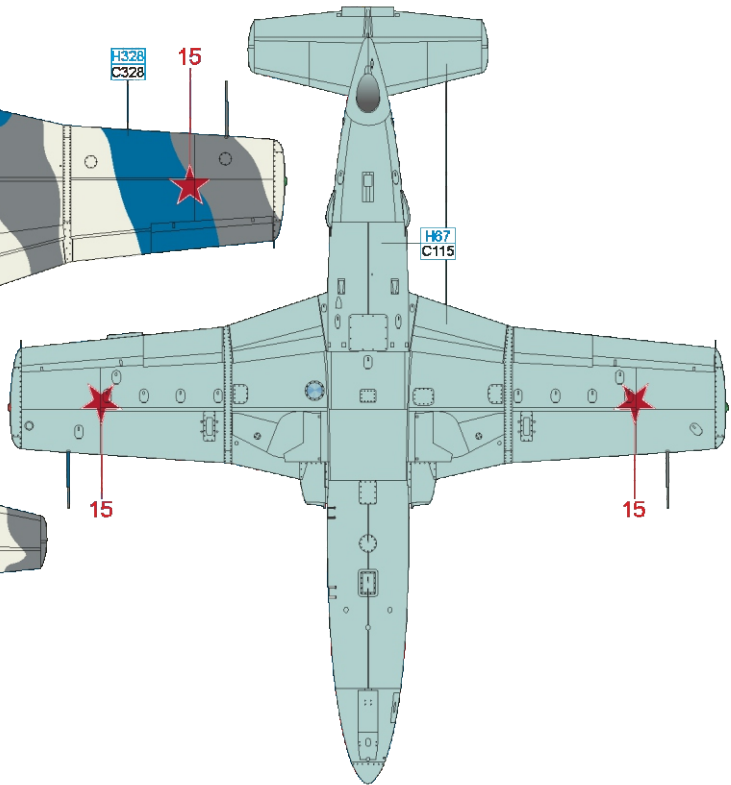
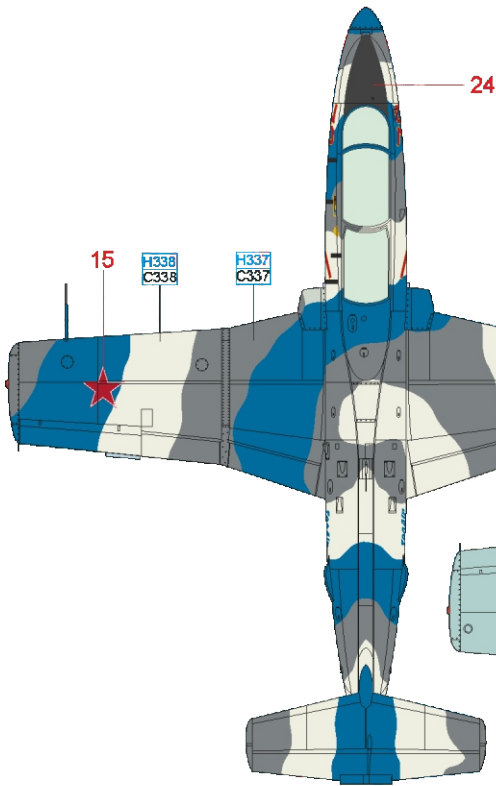

LIGHT BLUE	H67 C115	LIGHT GRAY	H338 C338	GRAY	H337 C337	BLUE	H328 C328
------------	-------------	------------	--------------	------	--------------	------	--------------

E 3246, 3rd Flight, 1 Fighter Regiment, Planá Air Base, Czechoslovakia, 1969–1970

While most L-29s served as trainers with training units, some aircraft were allocated to combat units to help in maintaining pilot's ratings at a minimal expense. One such aircraft was this L-29 coded 3246, which was assigned to 3 Squadron of the 1 Fighter Regiment based at České Budějovice. The aircraft served there right from its acceptance in 1969 up to the mid-eighties. Later, it was transferred to a training regiment in Košice and stayed operational up to 2003. During 1969–70, the Squadron emblem was painted on the nose consisting of a devil on a dark blue background, the same as used on MiG-21PFMs of the unit. The red trim was part of the standard scheme in which the L-29s were delivered to the main client, the Soviet Union.

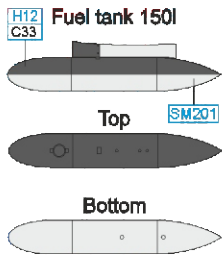
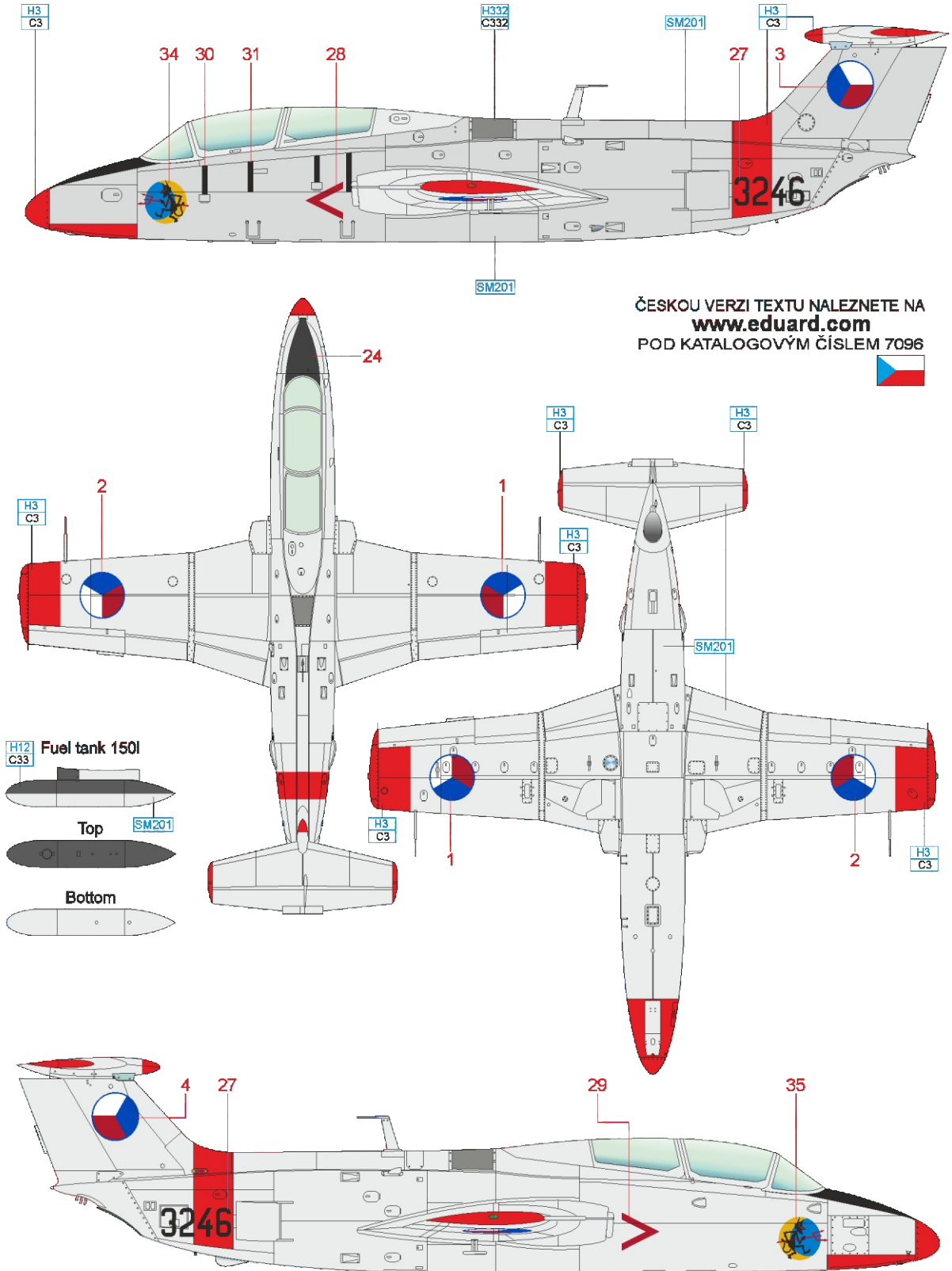

SUPER FINE SILVER SM201 RED H3 C3 LIGHT AIR. GRAY H332 C332 BLACK H12 C33

