

# Albatros D.V

eduard

1/72 Scale Plastic Model Kit

**WEEKEND**  
edition



item No. 7406

The Albatros D.V was not what it meant to be. The successor to the D.III did not improve the performance significantly, while the structural problems, already known with the predecessor, got even worse. All in all the D.V was nothing more than an interim solution before the Fokker D.VII replaced it on the production lines ending the tale of the Albatros scouts in Great War.

The D.V represents the final step in the development of the Albatros scouts family originating to the D.I type introduced in August 1916. The development led to the D.II and D.III scouts, which were of wide use with the Jagdstaffeln but as the development of opponents intensified, also the German Luftstreitkräfte needed to raise their game. Albatros was the main supplier of the fighter aircraft at the time, and it was no wonder the Idflieg made an order for an improved version in April 1917 to stop the supremacy of the new British scout, the S.E.5a.

#### Just a small step

The chief designer Robert Thelen was already aware of the situation, but the result of his work, the D.IV did not mature to the production stage. On the other hand, it proved the more streamlined fuselage would be the next important step in the development. The resulting D.V resembled the D.III closely and also used the same 170 hp (127 kW) Mercedes D.IIIa engine, but the fuselage got elliptical cross-section and saved some 71 lb (32 kg) of weight compared to the predecessor. The tailplane remained unchanged from the D.III as the prototype D.V retained the standard rudder of the Johannisthal-built D.III, but the production examples used the enlarged rudder of the OAW-built D.III. Other changes included a larger spinner and ventral fin, the upper wing was 4.75 in (120 mm) closer to the fuselage and the lower wing joined with the fuselage without a fairing.

The wings themselves were almost identical to those of the standard D.III, as Thelen retained the sesquiplane concept adopted with the D.III. The only visible difference to the wings of D.III was a revised routing of the aileron cables that kept them fully within the upper wing. As the wings stayed nearly unchanged, the Idflieg decided to conduct the structural tests on the fuselage only. The move proved to be a big mistake...

The first production batch contract called for 200 D.Vs in April 1917, the other contract for next 400 aircraft followed in May and 300 more were ordered in July. All of them were produced in the main Johannisthal Albatros factory, while the subsidiary OAW factory at Schneidemühl kept production of D.III.5s.

Early examples of the new D.V featured a large headrest, but this feature was usually removed at Jagdstaffeln, as it limited pilot's rear view. Starting from second production batch, the headrest was deleted at the factory level.

#### The disaster

The new D.V entered service in May 1917 and it did not take long for pilots and personnel to realise the structural problems with

the lower wing, already known with D.III got even worse with the new aircraft. The Idflieg decided to conduct the new structural tests only to find these voices were right. More to it, also problems with the upper wing surfaced and required additional bracing. And as if these were not enough the structural problems also appeared with the new fuselage, which sometimes cracked because of the hard landing. And all these problems were not counterbalanced by better performance.

The D.V offered just a little performance increase over its predecessor, so many pilots still preferred the D.III. The most famous of them all, Manfred von Richthofen, even spoke his thoughts out in the letter written in July 1917. He described the D.V as "so obsolete and so ridiculously inferior to the English that one can't do anything with this aircraft".

Albatros tried to respond with the D.Va type, featuring stronger wing spars and ribs. Also the fuselage was reinforced. The changes added some weight inevitably so the D.Va was 51 lb (23 kg) heavier than D.III, while the problems were still not fully solved. To further strengthen the wing, the D.Va added a small diagonal brace connecting the forward interplane strut to the leading edge of the lower wing. That was one of two visible differences between D.V and D.Va. The second one was the same aileron cable linkage as used with D.III. The change was made to provide a swifter control response. The more powerful Mercedes D.IIIaü developing 180 hp (130 kW) helped to offset the added weight somehow.

#### Better than nothing

The Idflieg placed order for 262 D.Va aircraft in August 1917, which was followed by orders for 250 more in September and 550 in October. Also OAW subsidiary was given the order to build 600 D.Va aircraft. The orders just reflected the situation at the end of 1917, as the Idflieg had no other option. The Pfalz D.III did not bring too much change in the game and the Fokker Dr.I was getting obsolete not to mention its own structural problems.

Production of the D.Va ceased in April 1918, freeing the production capacity of both Albatros factories for the new Fokker D.VII, which solved all the problems the Jagdstaffeln were suffering performance-wise during the winter of 1917 and spring of the 1918.

Despite all its shortcomings and general obsolescence, some 900 D.Vs and 1,612 D.Vas were built. Their numbers were decreasing rapidly and by August 31, 1918 only some 400 Albatros fighters of all types remained in the frontline use.

ATTENTION



UPOZORNĚNÍ



ACHTUNG



ATTENTION



注意



Carefully read instruction sheet before assembling. When you use glue or paint, do not use near open flame and use in well ventilated room. Keep out of reach of small children. Children must not be allowed to suck any part, or pull vinyl bag over the head.



Před započítím stavby si pečlivě prostudujte stavební návod. Při používání barev a lepidel pracujte v dobře větrané místnosti. Lepidla ani barvy nepoužívejte v blízkosti otevřeného ohně. Model není určen malým dětem, mohlo by dojít k požití drobných dílů.

INSTRUCTION SIGNS

\* INSTR. SYMBOLY

\* INSTRUKTION SINNBILDEN

\* SYMBOLES

\* 記号の説明

OPTIONAL  
VOLBABEND  
OHNOUTSAND  
BROUSITOPEN HOLE  
VYVRTAT OTVORSYMETRICAL ASSEMBLY  
SYMETRICKÁ MONTÁŽREMOVE  
ODRÍZNOUTREVERSE SIDE  
OTOČITAPPLY EDUARD MASK  
AND PAINT  
POUŽÍT EDUARD MASK  
NABARVIT

PARTS



DÍLY



TEILE



PIÈCES



部品

## PLASTIC PARTS

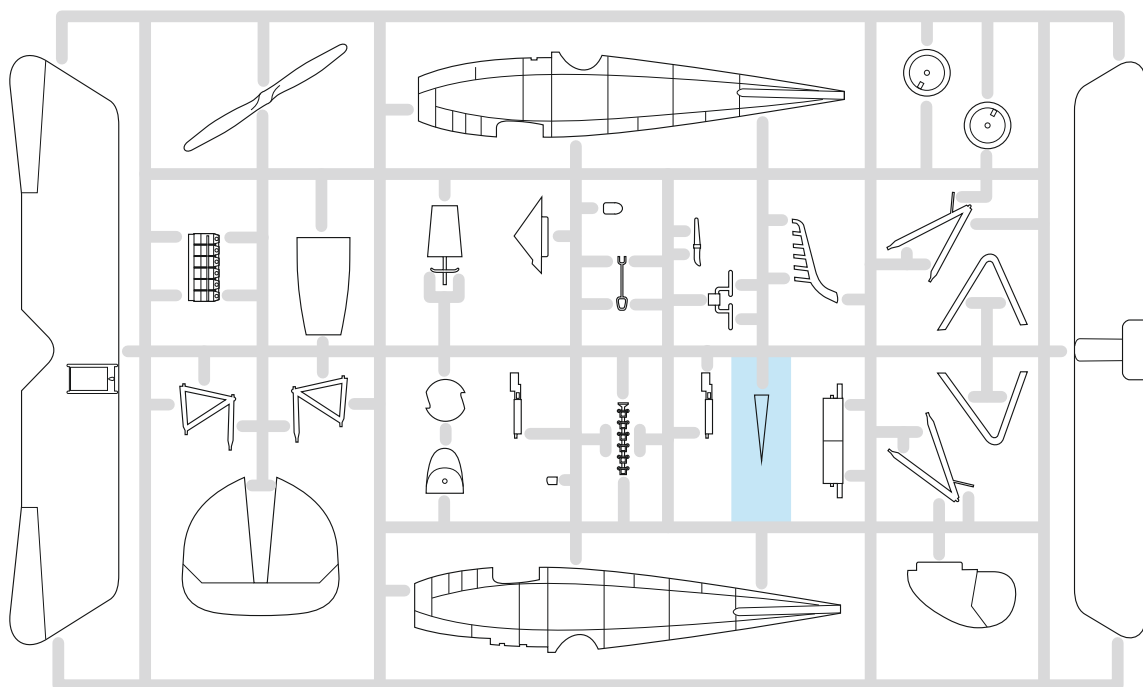

-Parts not for use. -Teile werden nicht verwendet. -Pièces à ne pas utiliser. -Tyto díly nepoužívejte při stavbě. - 使用しない部品

COLOURS



BARVY



FARBEN



PEINTURE



色

GSI Creos (GUNZE)		MISSION MODELS	
AQUEOUS	Mr.COLOR	PAINTS	
H6	C6	MMP-004	GREEN
H8	C8		SILVER
H11	C62	MMP-001	FLAT WHITE
H12	C33	MMP-047	FLAT BLACK
H23	C79		SHINE RED
H25	C34		SKY BLUE
H37	C43		WOOD BROWN
H39	C67		PURPLE
H51	C11	MMP-063	LIGHT GULL GRAY
H47	C41	MMP-012	RED BROWN

GSI Creos (GUNZE)		MISSION MODELS	
AQUEOUS	Mr.COLOR	PAINTS	
H70	C60	MMP-056	GRAY
H314	C314		BLUE
H327	C327	MMP-101	RED
H330	C361	MMP-077	DARK GREEN
H413	C113	MMP-090	YELLOW
Mr.METAL COLOR		METALLICS	
MC214		MMM-001	DARK IRON
MC219		MMM-009	BRASS
Mr.COLOR SUPER METALLIC		METALLICS	
SM201		MMC-001	SUPER FINE SILVER

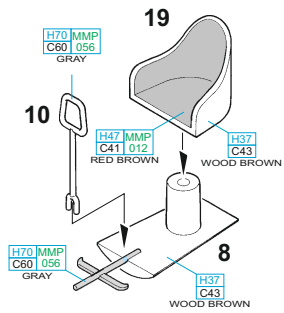
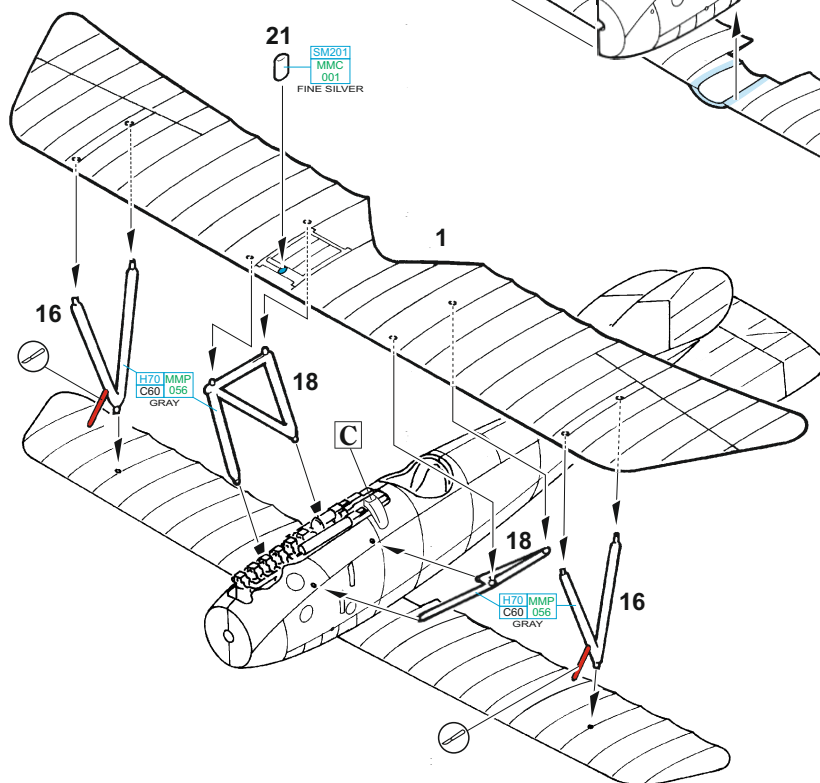
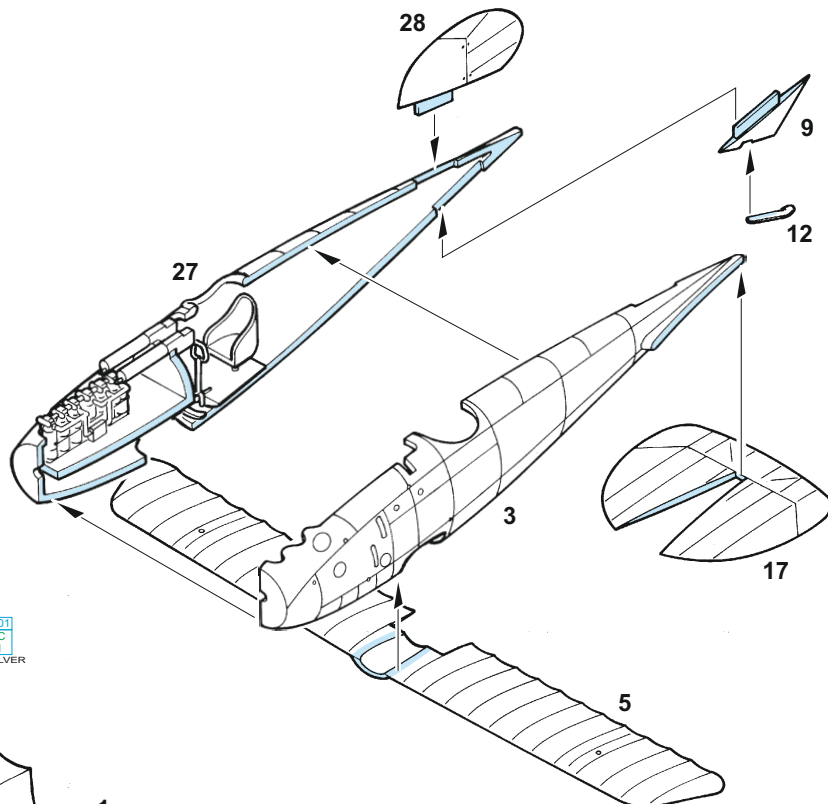
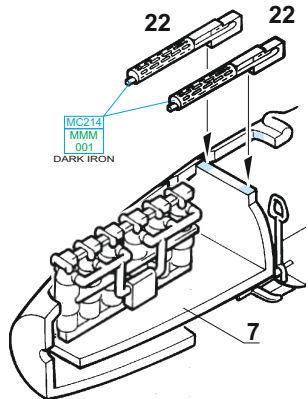
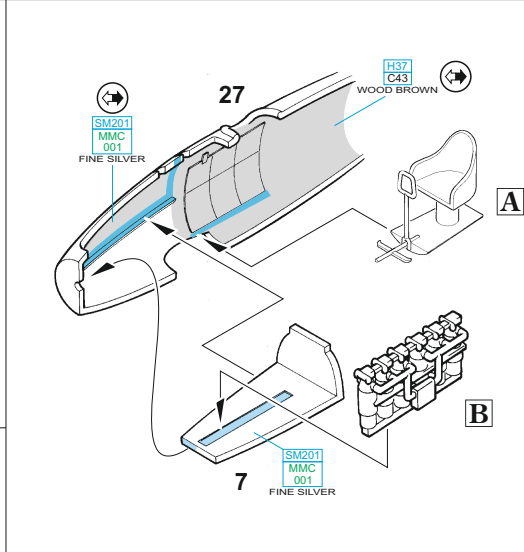
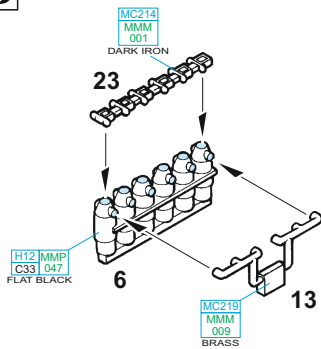
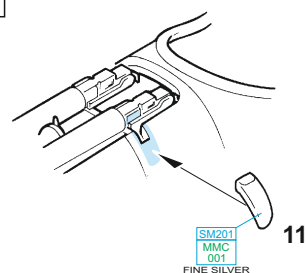
**A****B****C**

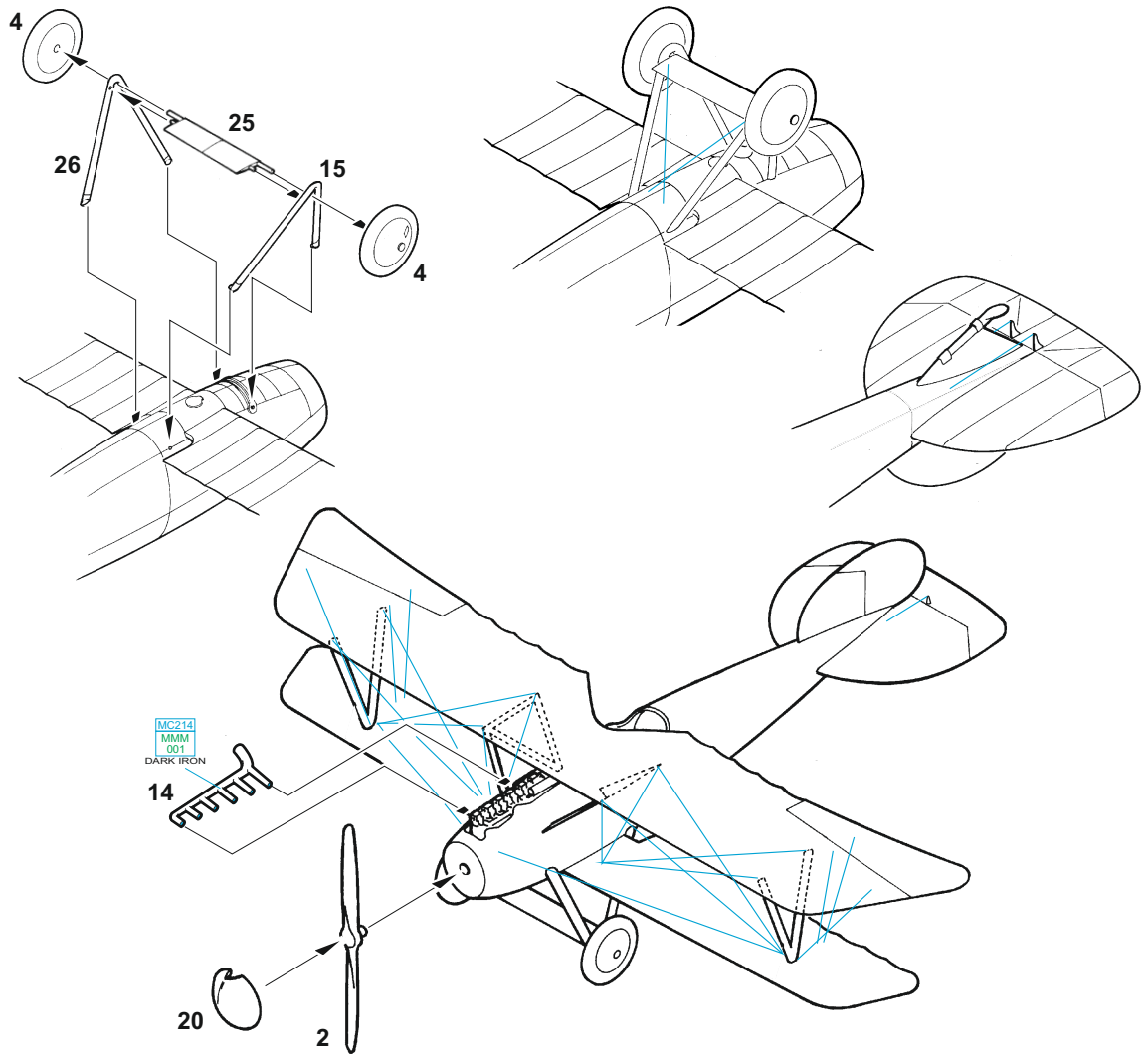

Albatros D.V / D.Va

RIB STRIPES

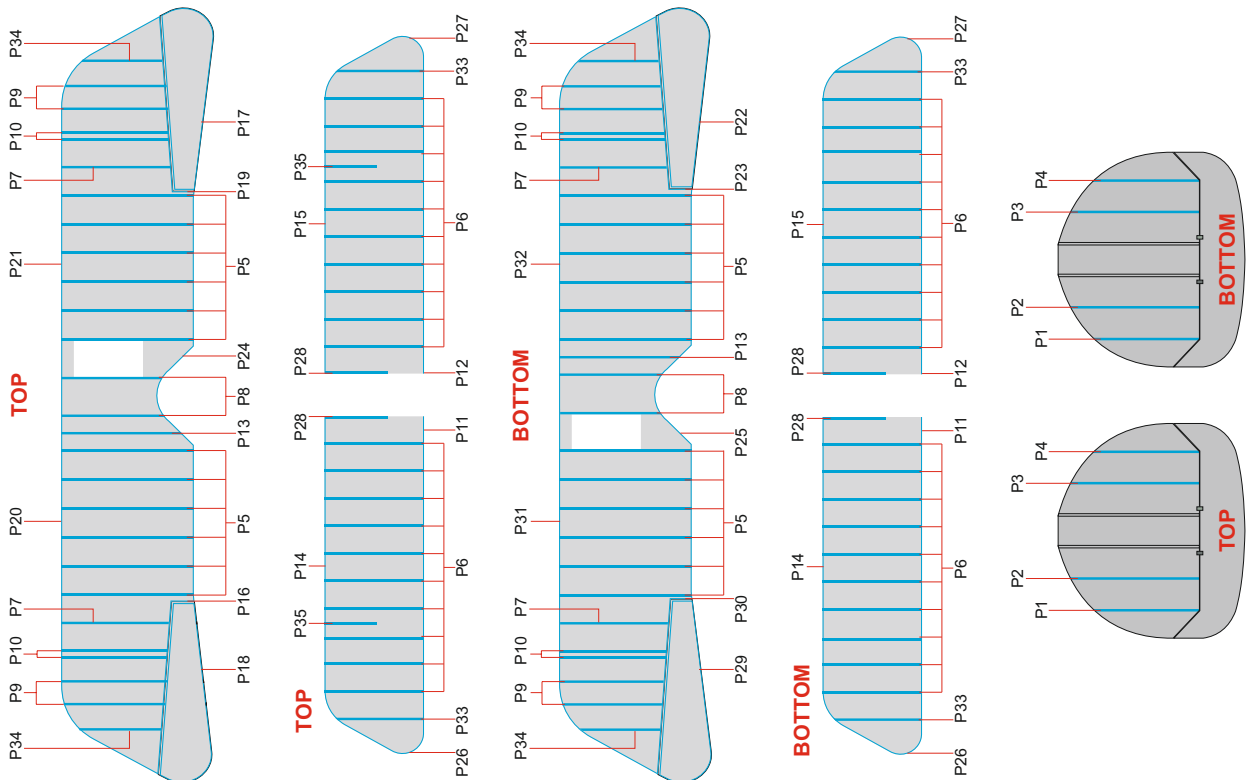

# A Albatros D.V 1154/17, Lt. Max Ritter von Müller, Jasta 28, Varsenare, Belgium, September 1917

Max Müller was the German ace with 36 victories. He finished his pilot course on April 4, 1914 and at the outbreak of the war, he joined Bavarian FFA1. Following his one-seaters course he joined KEK Nord in May 1916 and after a short spell with Jasta 1 he got tempted by the offer of Oswald Boelcke to join the Jasta 2. Müller achieved his first victory on October 10 and added four more before the end of the year. On January 20, 1917 he was transferred again, now to the new Jasta 28, where he became the most successful pilot of the unit. By the end of the 1917 his score had risen to 36 victories and Müller decided to return to his "old" Jasta 2. But after the death of Walter von Bülow, the CO of Jasta 28, Müller was appointed deputy leader of the unit. He took off for his first Staffelführer combat flight on January 9, 1918 and it turned out to be also his last flight. The fuel tank of his Albatros was hit during combat with R.E.8, the aircraft caught fire and went down in flames. With no parachute and inevitable dreadful death Müller opted to bail out from the cockpit to his inevitable end. His Albatros D.V sported personal marking of the stylised black comet; the fuselage got the red painting to reflect the new Staffelführer status. The horizontal stabiliser was in yellow with black longitudinal stripe – the unit's colour markings.

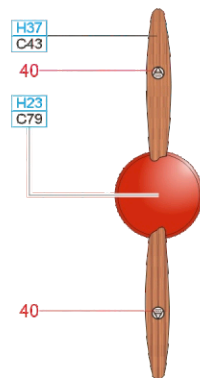
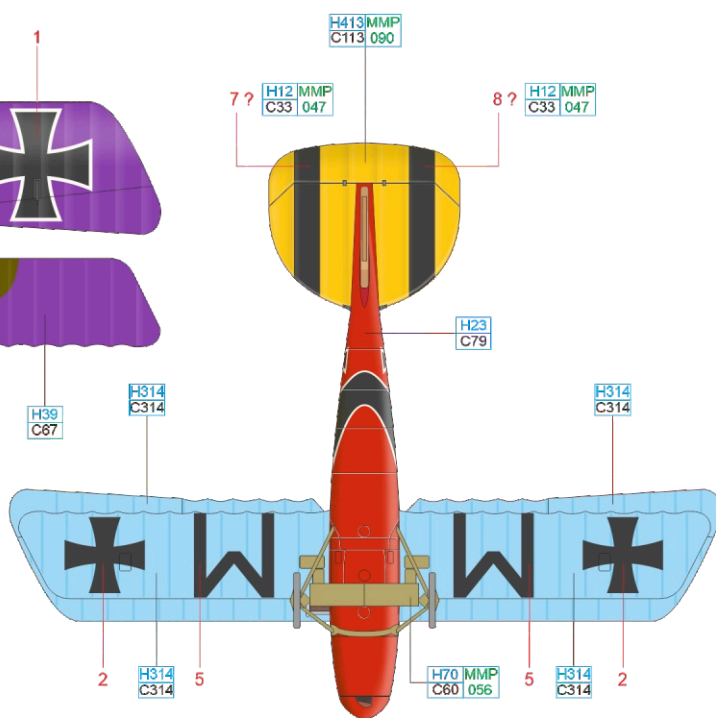
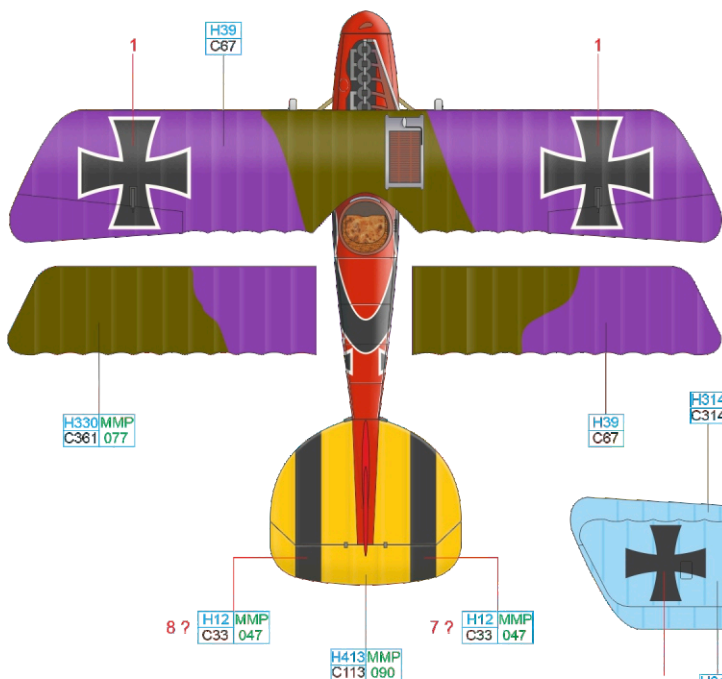
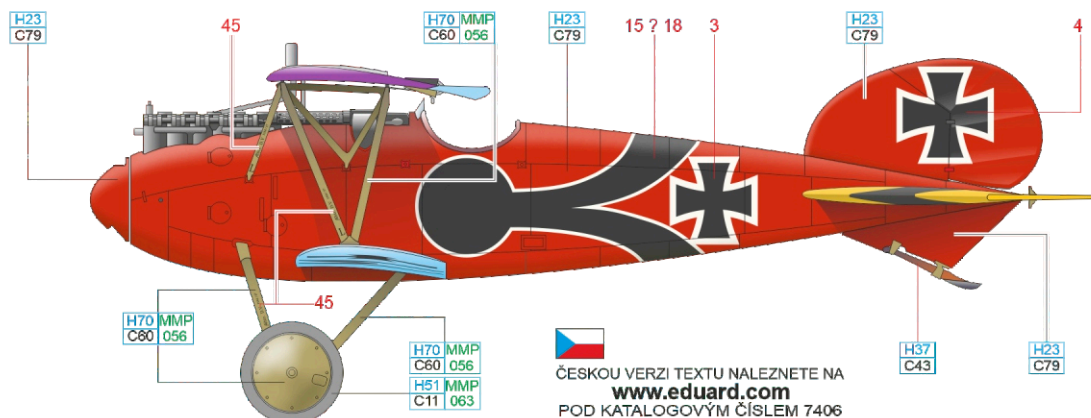

LIGHT GULL GRAY	H51 MMP C11 063	LIGHT BLUE	H314 C314	BLACK	H12 MMP C33 047	WOOD	H37 C43	RED	H23 C79
GREEN GRAY	H70 MMP C80 056	VIOLET	H39 C67	YELLOW	H413 MMP C113 090				
GREEN	H330 MMP C361 077								



**C** Albatros D.V 4629/17, Lt. Hans-Joachim von Hippel, Jasta 5, Boistrancourt, France, February 1918

Hans von Hippel served with Jasta 5 from December 22, 1917 until August 15, 1918, when he was transferred to Jasta 71. He claimed four victories, but only two were confirmed. One of these non-confirmed ones were reported by von Hippel on the Russian front when flying with FA 37. During WWII Hippel flew Ju 52s with the Luftwaffe. He died in 1975. Hippel flew Richard Flashar's Albatros D.V with red dragon painted on the fuselage (2065/17) for some time, as he damaged this Albatros D.V during the take-off attempt from the grassland. Von Hippel tried to rescue his crash-landing comrade Lt. Schlömer, but the take-off was interrupted by the engine malfunction. Later he flew another Albatros D.V with his personal marking of black, white outlined zigzag arrow on both sides of the fuselage. Apart of this aircraft with the green/mauve camouflage of the upper surfaces, the later one had the Flugzeugstoff covered wings (Lozenge). The fuselage of both was painted with the Pfalz silvery „Schutzfarbe“, which was of good supply to the Jagdstaffeln using the Pfalz D.III's scouts as well.

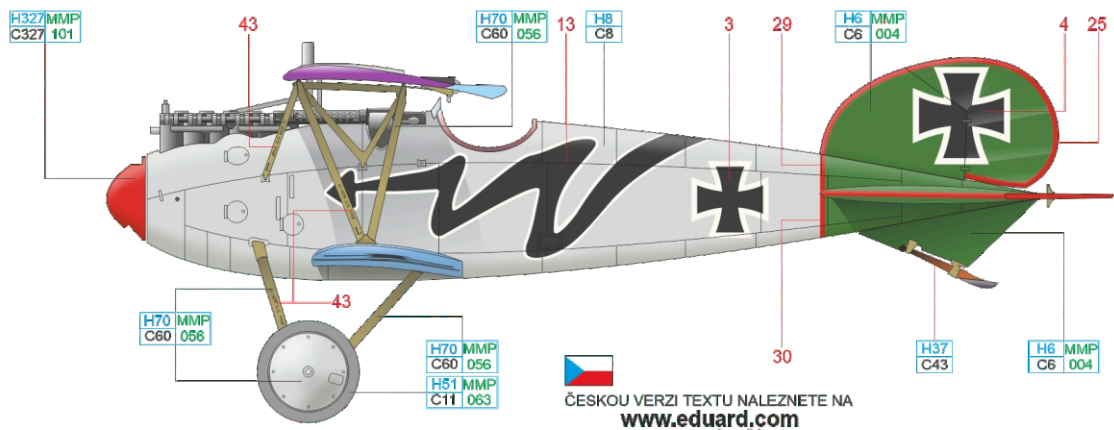

ČESKOU VERZI TEXTU NALEZNETE NA [www.eduard.com](http://www.eduard.com)  
 POD KATALOGOVÝM ČÍSLEM 7406

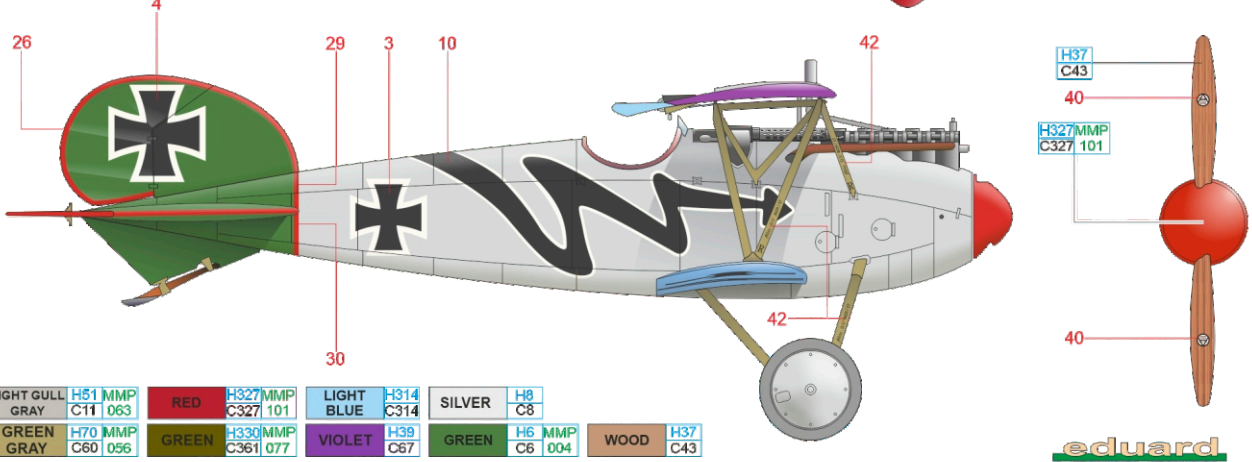
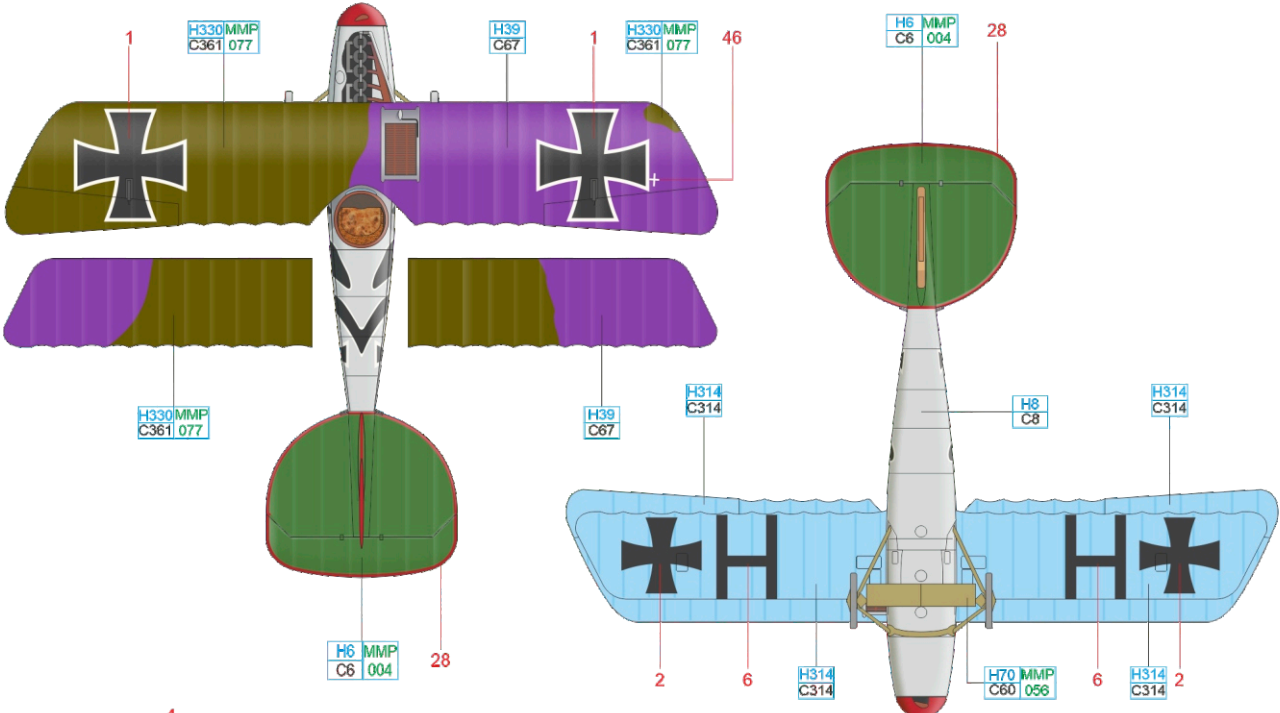

LIGHT GULL GRAY	H51 MMP C11 063	RED	H327 MMP C327 101	LIGHT BLUE	H314 C314	SILVER	H8 C8
GREEN GRAY	H70 MMP C60 056	GREEN	H330 MMP C361 077	VIOLET	H39 C67	GREEN	H6 MMP C6 004
						WOOD	H37 C43

# D Albatros D.V 2299/17, Lt. Xaver Dannhuber, Jasta 26, Abeele, Belgium, 1917

Although this Albatros D.V is usually assigned to Bruno Loerzer, it is very probable, it was in fact the mount of Xaver Dannhuber, the winner in 11 aerial combats. Apart of other indications, he was photographed himself standing by the plane or sitting in the cockpit. Dannhuber first saw action with Kagohl 6 (Kampfgeschwader der Obsten Heeresleitung – Combat squadron of the Supreme Commander), later was transferred to Schutzstaffel 25, before he was assigned to Jasta 26 on July 1, 1917. Dannhuber got wounded upper arm in an air fight on October 18 and after his return on November 7, he moved to Jasta 79b as he was appointed the CO of the unit. He was injured in a crash when test-flying a Pfalz D.IIIa at the Thugny airfield on February 11, 1918. After several months of medical treatment and convalescence Dannhuber had returned to his unit and reassumed command on October 9. Five days later he achieved his 11<sup>th</sup> and last victory, shooting down Sopwith Dolphin near Bohain. His Albatros was painted in black and white bands scheme typical for Jasta 26 aircraft. It also sported the six-pointed star on both sides of the fuselage and five-colour Flugzeugstoff on the wings.

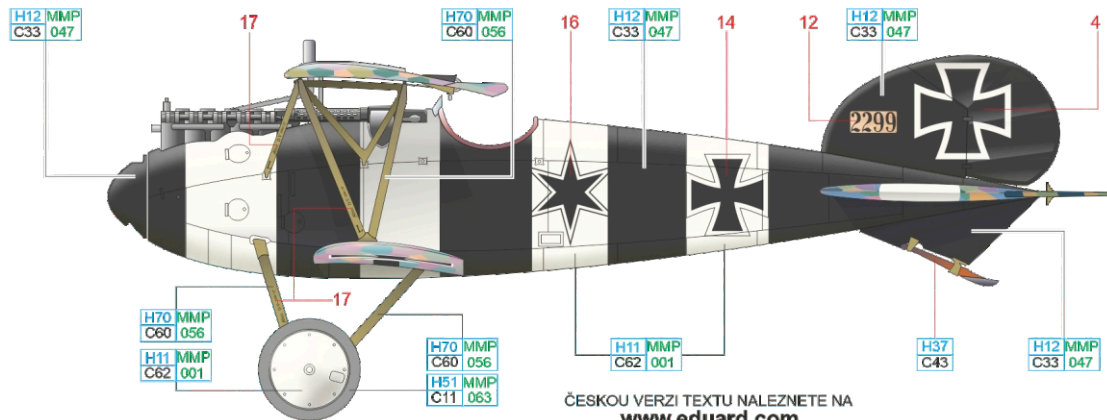

ČESKOU VERZI TEXTU NALEZNETE NA  
[www.eduard.com](http://www.eduard.com)  
 POD KATALOGOVÝM ČÍSLEM 7406

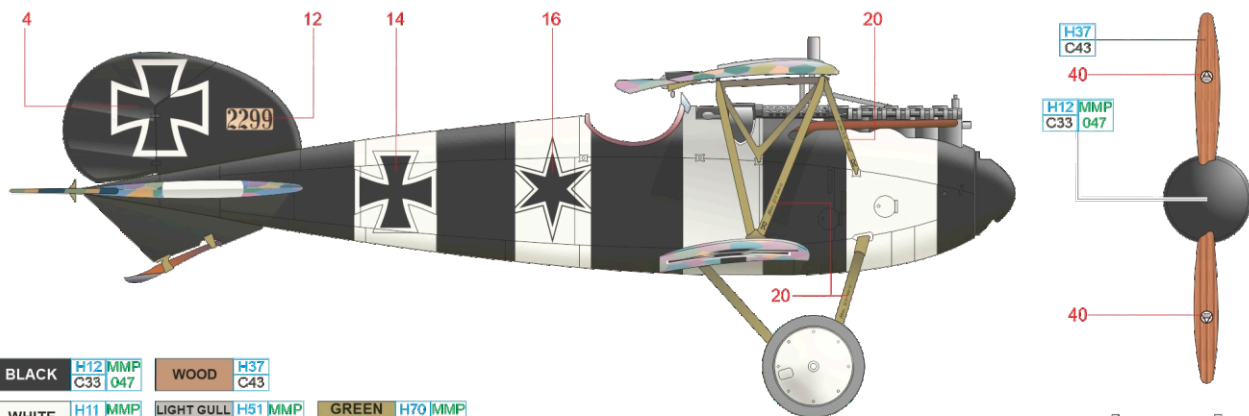
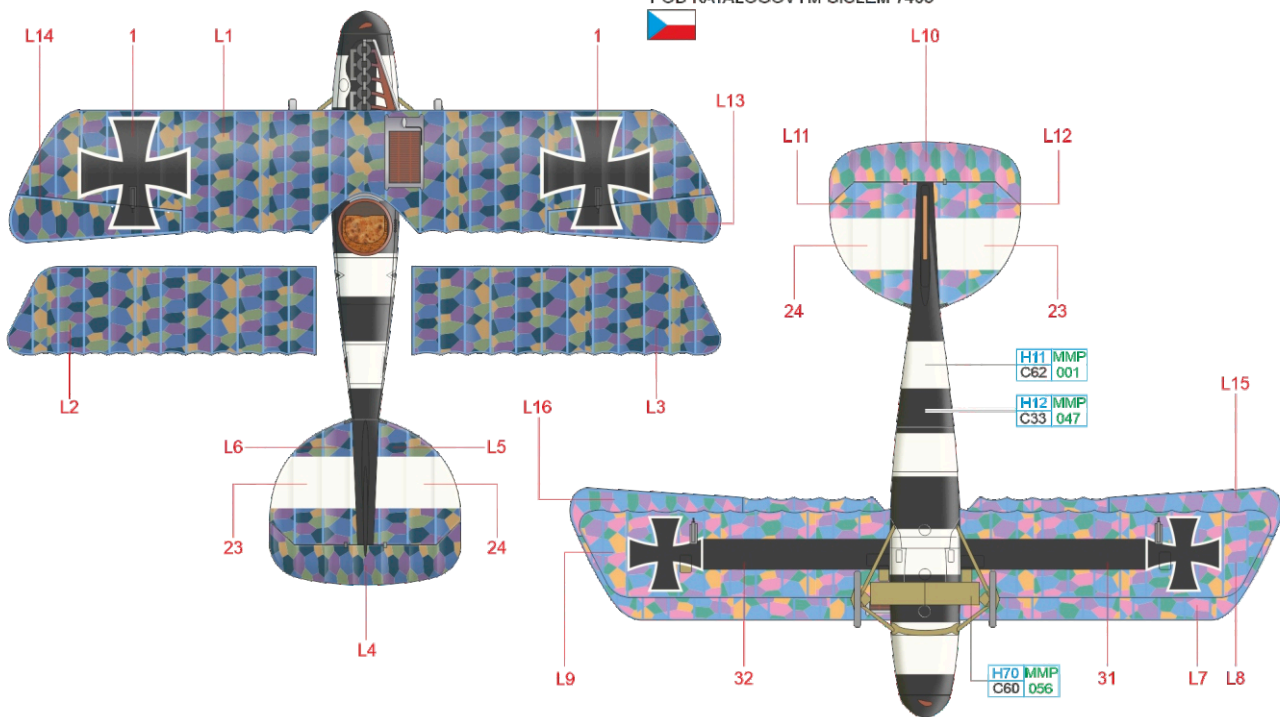

BLACK	H12 MMP C33 047	WOOD	H37 C43
WHITE	H11 MMP C62 001	LIGHT GULL GRAY	H51 MMP C11 063
		GREEN GRAY	H70 MMP C80 056

eduard