

intro

The second half of the Second World War saw the Focke-Wulf Fw190, in its various forms, emerge as the best of what was available to the Luftwaffe. The dedicated fighter version was a high performance, heavily armed machine. Its development had a precarious beginning, against a 1938 specification issued by the Technisches Amt, RLM. The first prototype took to the air on June 1, 1939. After a series of improvements and even radical changes, the design culminated in the fall of 1940 in the pre-series version Fw190A-0 to the tune of twenty-eight pieces. Six of these were retained by the test unit Erprobungsstaffel 190 at Rechlin, which was tasked with conducting service trials. These revealed a wide range of flaws to the point where the RLM halted further development. Despite this, on the basis of urgings from the test unit staff, the aircraft was not shelved. After a series of some fifty modifications, the RLM gave the go ahead for the Fw 190 to be taken into inventory of the Luftwaffe. In June, 1941, the Luftwaffe accepted the first of 100 ordered Fw 190A-1s, armed with four 7.9 mm MG 17s. By September, 1941, II./JG 26 was completely equipped with the type, operating on the Western Front. November saw the production of the next version Fw 190A-2, powered by a BMW 801C-2, and armed with two 7.9 mm MG 17s and two MG 151s of 20 mm caliber in the wings. Part of this series received an additional pair of 20 mm MG FFs, thus attaining an armament standard of later types. A significant advancement to the design came in the spring of 1942, when the BMW 801D-2 became available, whose installation gave birth to the Fw 190A-3. July saw the development of the improved A-4. Both were armed with what became the standard two fuselage mounted MG 17s, two wing mounted MG 151 cannon, and two MG FF cannon, placed inboard of the wheel wells. During 1942, production had intensified, and a production facility was set up under license at Fieseler. Thanks in part to this, production rose in 1942 to 1,878 units as opposed to 224 in 1941. Large-scale production of the A-5 was initiated in April, 1943, with an identical wing to the A-4, but with a nose extension that would become standard on all subsequent Fw 190A versions up to the A-9, and also on the corresponding F types. July saw the development of a new, strengthened wing, which incorporated MG 151s instead of the MG FFs in the outer position. The adoption of this wing developed the A-6 version. Further changes developed the A-7, produced during the end of 1943. This version came about with the replacement of the fuselage mounted MG 17s with 13 mm MG 131s. Further improvements led to the Fw 190A-8, and this version became the most widely produced with some 1400 units made. The most significant change to this variant was the installation of the GM-1 nitrous-oxide injection system, for temporary power boost in combat. A portion of A-8 production was built as the A-8/R2 and A-8/R8, armed with MK 108 cannon in the outer wing location, and with armoured slabs added to the cockpit sides and a modified canopy. The final production version of the BMW 801 powered fighter was the Fw 190A-9, equipped with the BMW 801TS of 2000 hp (1470kW). There was a parallel development of these fighter optimized aircraft with a dedicated fighter-bomber version, the Fw 190F. These aircraft had reduced wing armament to two MG 151 cannon in the wingroot position. The engine was optimized for low level operation, and the armament options varied to satisfy the ground attack role, including bombs of various weight classes and a variety of anti-tank rockets. This branched into the extended range Fw190G version. Development of the thoroughbred fighter continued in the guise of the Fw190D, which began to reach Luftwaffe units in the second half of 1944, and was the result of mounting an in-line Jumo 213A-1 engine into a modified Fw 190A-8 airframe. Although the Fw190 never achieved the widespread usage of the competing Bf 109, its contribution to the German Air Force was certainly significant through the second half of WWII. Fw 190s saw service on the Western Front as well as in the East. As heavy fighters with imposing firepower, they found themselves integral components, from 1943 onwards, within the units tasked with the protection of the Reich from the ominous clouds of allied fourengine bombers. This is where the A-8 version was instrumental, along with its A-8/R2 armoured development. This version, with its firepower, was a very ominous and daunting foe for the bomber crews. From the second half of 1944, their danger was kept in check to a degree by escorting P-47s, and necessitated the development of the P-51 Mustang.

PLASTIC PARTS

A>

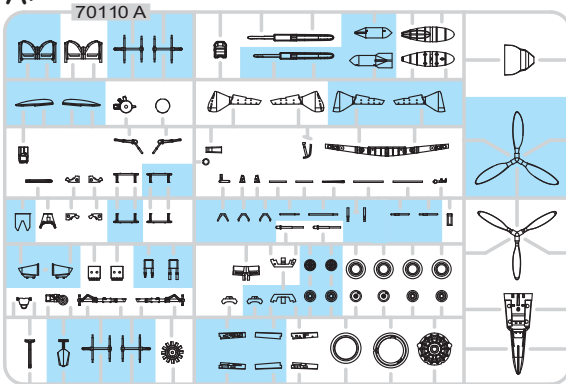

D>

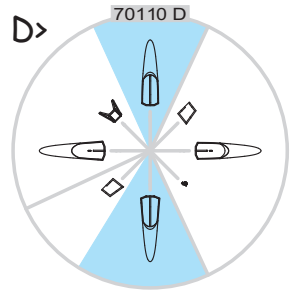

E>

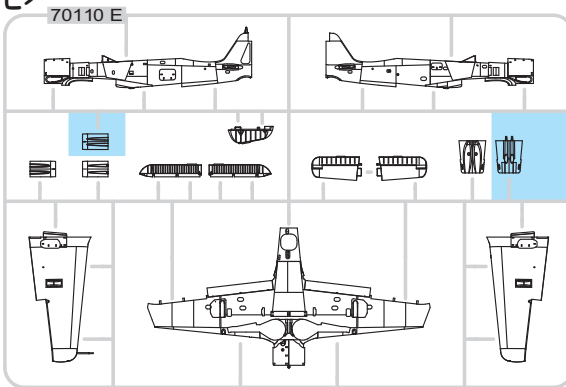

Mr.COLOR	
C2	BLACK
C3	RED
C7	BROWN
C17	DARK GREEN
C18	BLACK GREEN
C33	FLAT BLACK
C36	GRAY GREEN
C37	GRAY VIOLET
C41	RED BROWN
C54	KHAKI GREEN
C60	GRAY
C62	FLAT WHITE
C81	RUSSET
C113	YELLOW
C116	BLACK GRAY
C117	LIGHT BLUE
C137	TIRE BLACK

Mr.COLOR SUPER METALLIC	
SM06	CHROME SILVER

Mr. METAL COLOR	
MC214	DARK IRON
MC213	STAINLESS

-Parts not for use. -Teile werden nicht verwendet. -Pièces à ne pas utiliser. -Tyto díly nepoužívejte při stavbě. - 使用しない部品

ATTENTION * UPOZORNĚNÍ * ACHTUNG * ATTENTION

(GB)

Carefully read instruction sheet before assembling. When you use glue or paint, do not use near open flame and use in well ventilated room. Keep out of reach of small children. Children must not be allowed to suck any part, or pull vinyl bag over the head.

(CZ)

Před započatím stavby si pečlivě prostudujte stavební návod. Při používání barev a lepidel pracujte v dobře větrané místnosti. Lepidla ani barvy nepoužívejte v blízkosti otevřeného ohně. Model není určen malým dětem, mohlo by dojít k požití drobných dílů.

(D)

Vor dem Zusammenbau die Bauanleitung gut durchlesen. Kleber und Farben nicht in der Nähe von offenem Feuer verwenden und für eine ausreichende Belüftung sorgen. Den Bausatz von kleinen Kindern fernhalten. Vermeiden Sie, dass Kinder Bauteile in den Mund nehmen oder sich Plastiktüten über den Kopf ziehen.

(F)

lire soigneusement la fiche d'instructions avant d'assembler. Ne pas utiliser de colle ou de peinture à proximité d'une flamme nue, et aérer la pièce de temps en temps. Garder hors de portée des enfants en bas âge. Ne pas laisser les enfants mettre en bouche ou sucer les pièces, ou passer un sachet vinyl sur la tête.

INSTRUCTION SIGNS * INSTR. SYMBOLY * INSTRUKTION SINNBILDEN * SYMBOLES



OPTIONAL
VOLBA



BEND
OHNOUT



OPEN HOLE
VYVRTAT OTVOR



SYMETRICAL ASSEMBLY
SYMETRICKÁ MONTÁŽ



REMOVE
ODŘÍZNOUT



REVERSE SIDE
OTOČIT

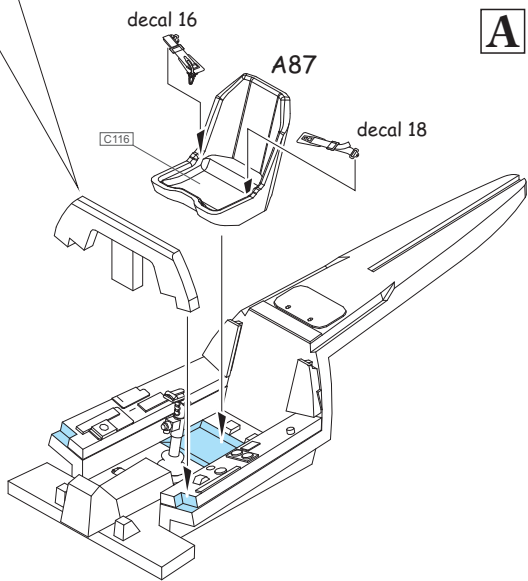
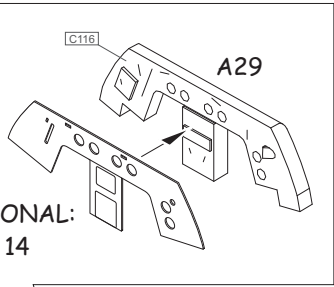
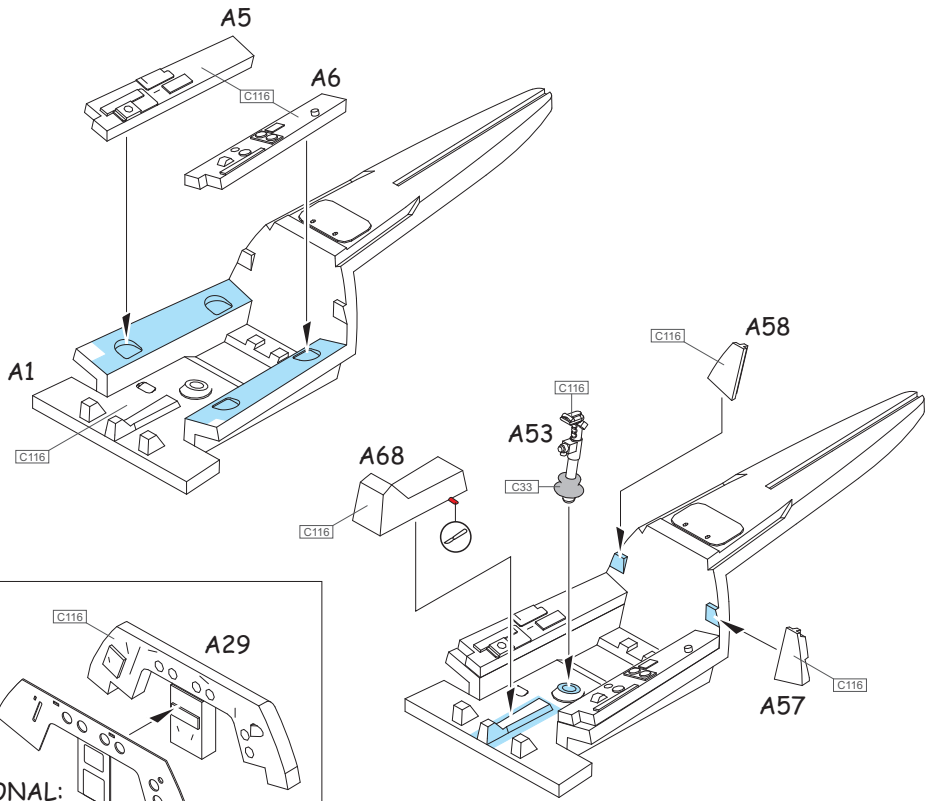

A

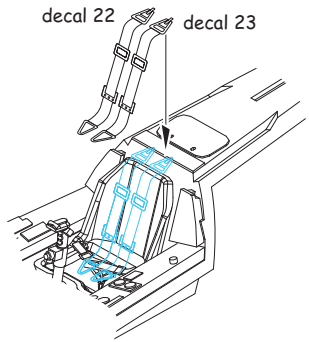

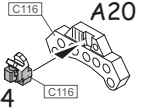
B

OPTIONAL:
decal 15

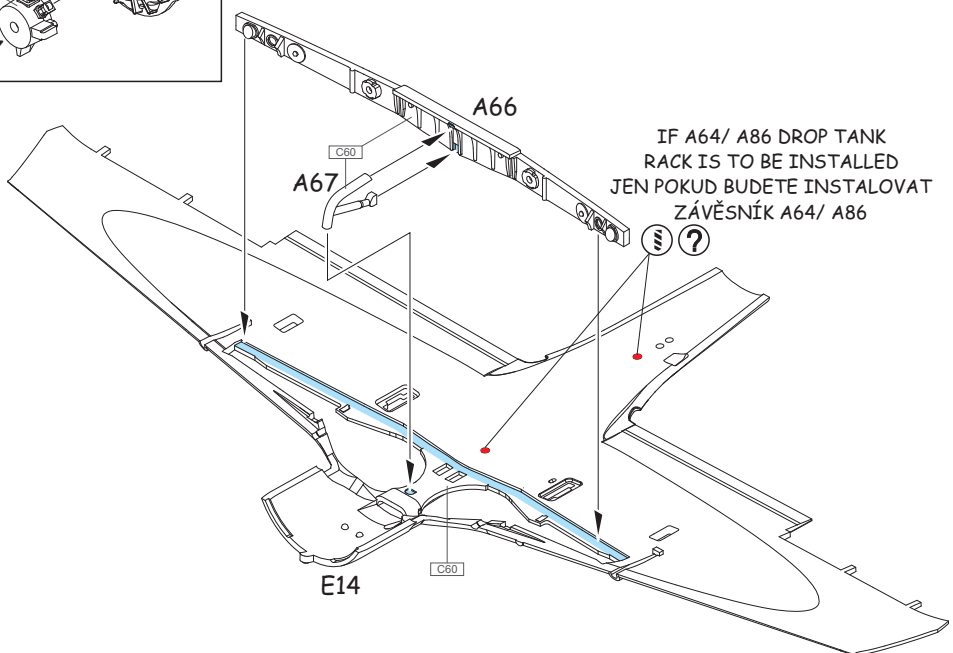
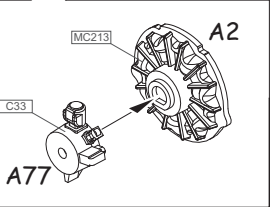
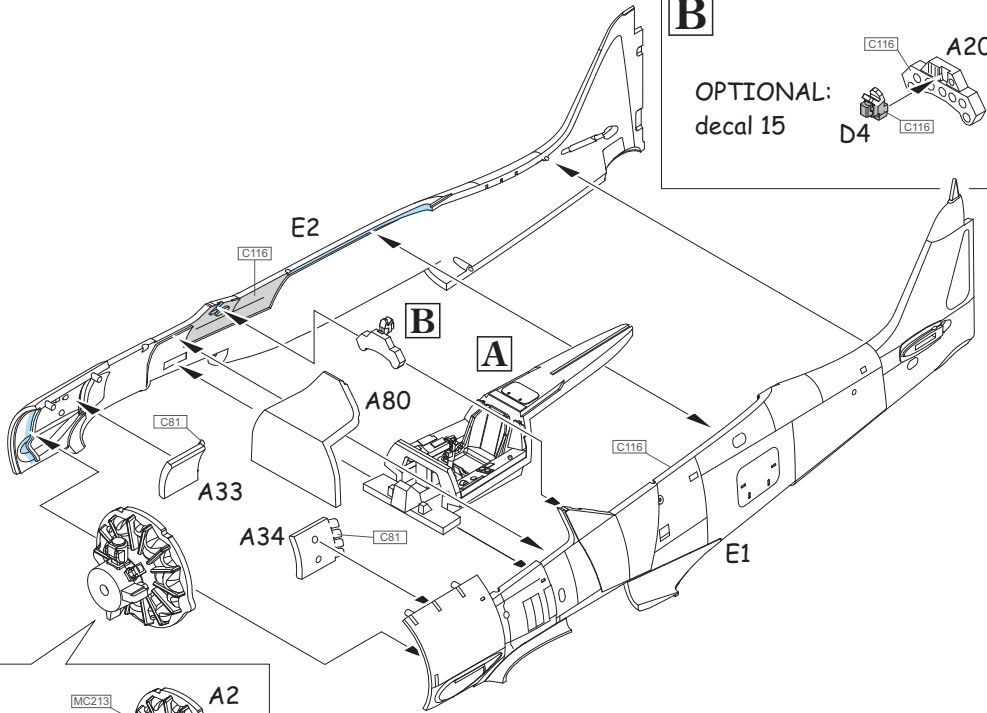

IF A64/ A86 DROP TANK
RACK IS TO BE INSTALLED
JEN POKUD BUDETE INSTALOVAT
ZÁVĚSNÍK A64/ A86



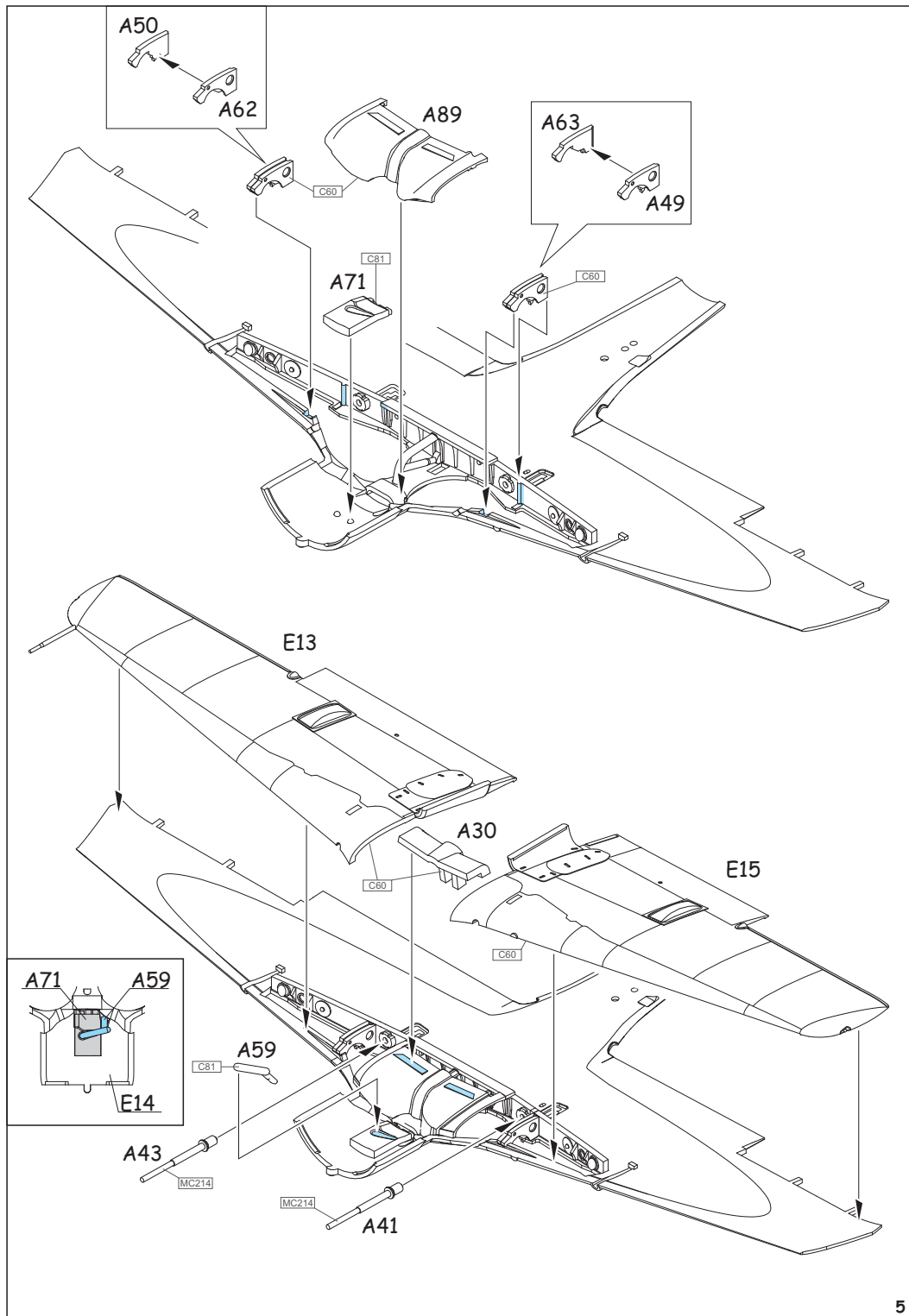

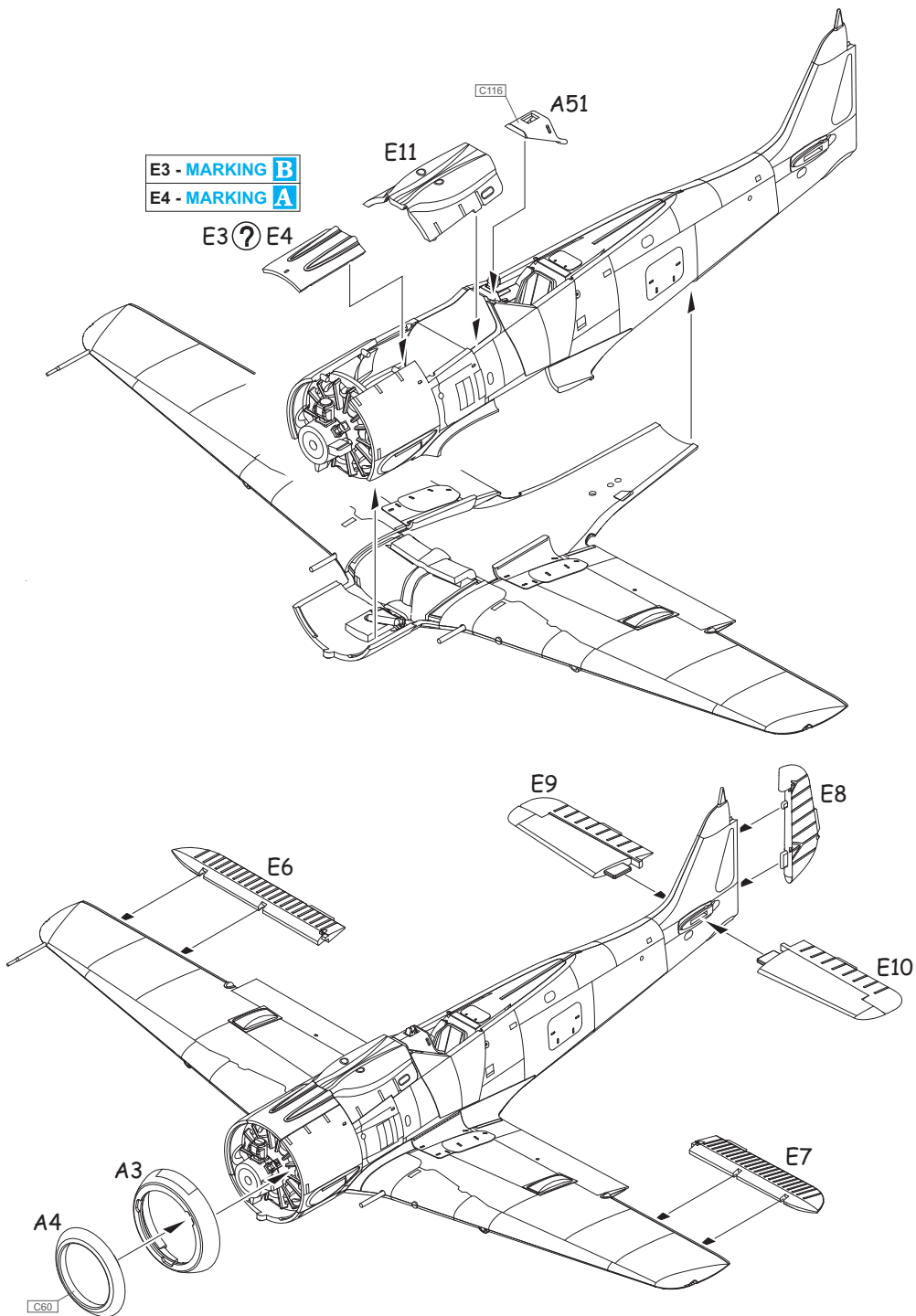

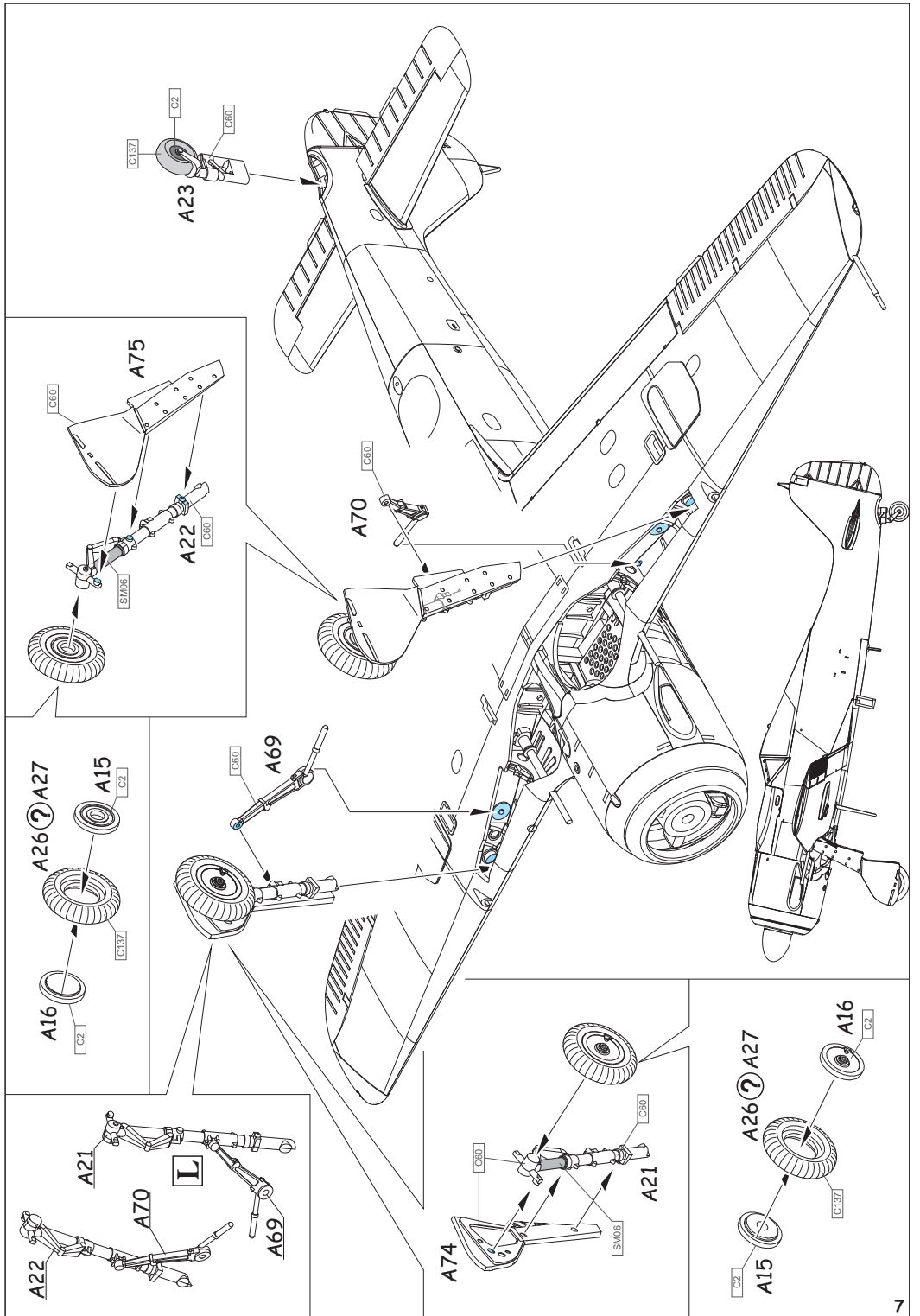

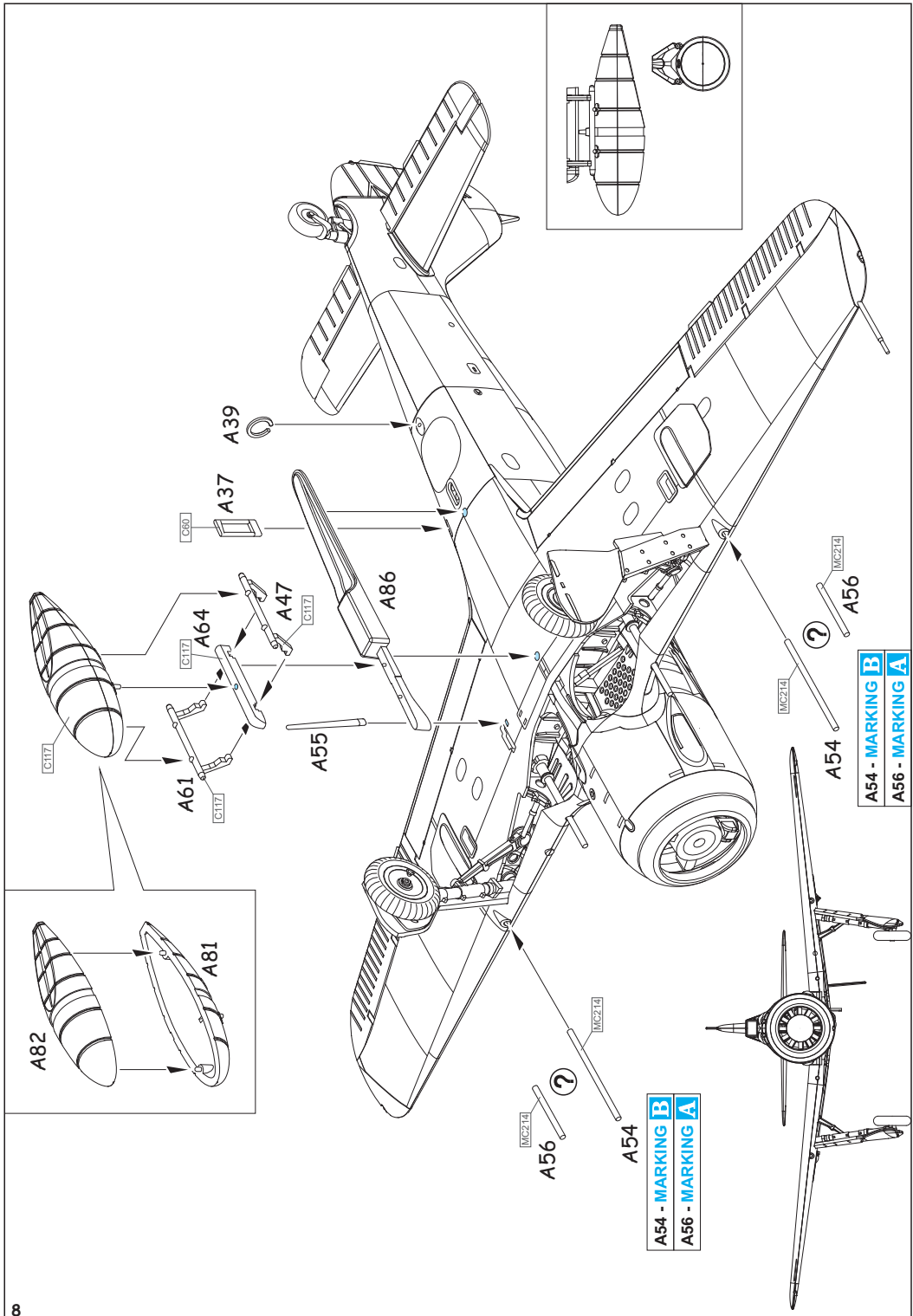

A54 - MARKING B
A56 - MARKING A

A54 - MARKING B
A56 - MARKING A

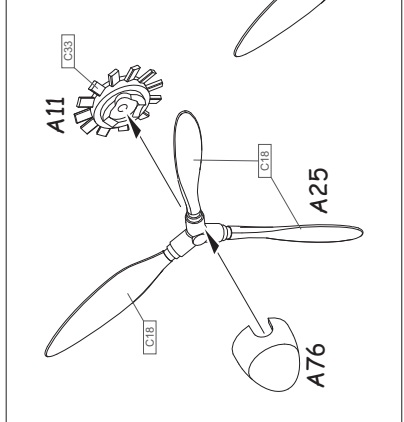
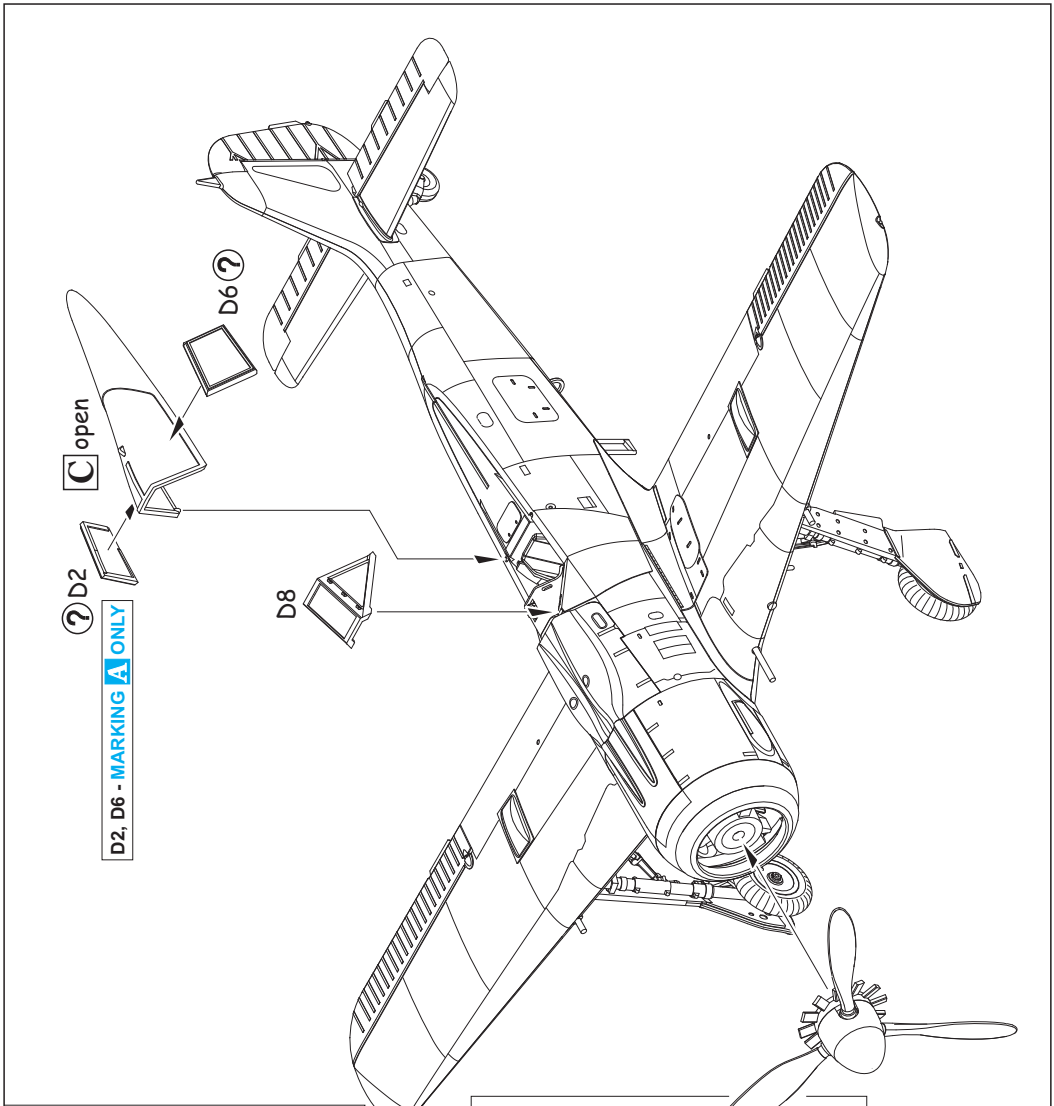
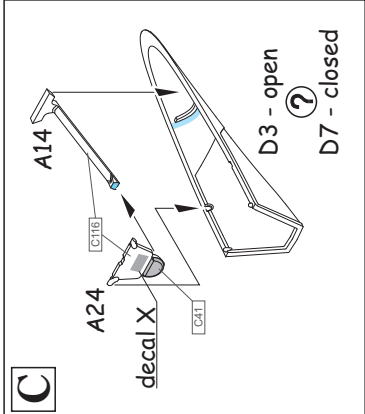

A Werner Gerth, II.(Sturm)/JG 3 "Udet", July, 1944

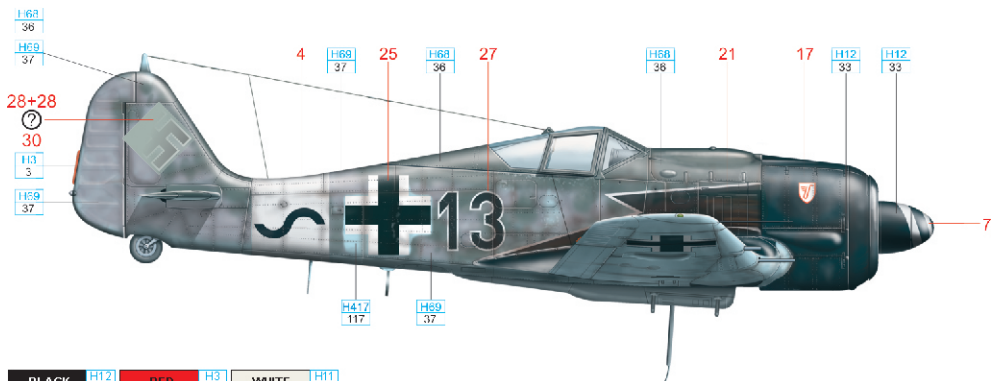
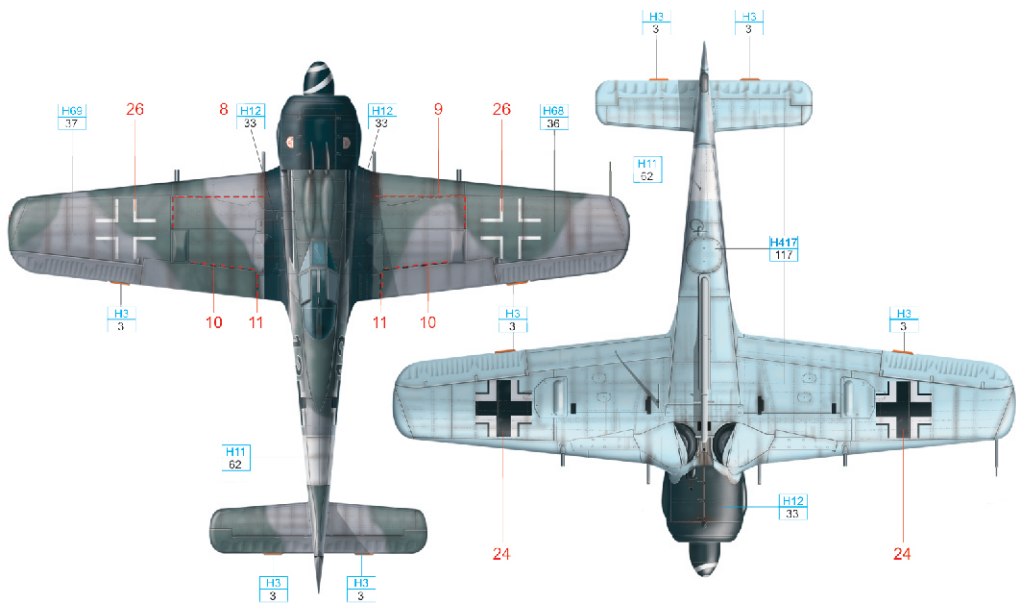
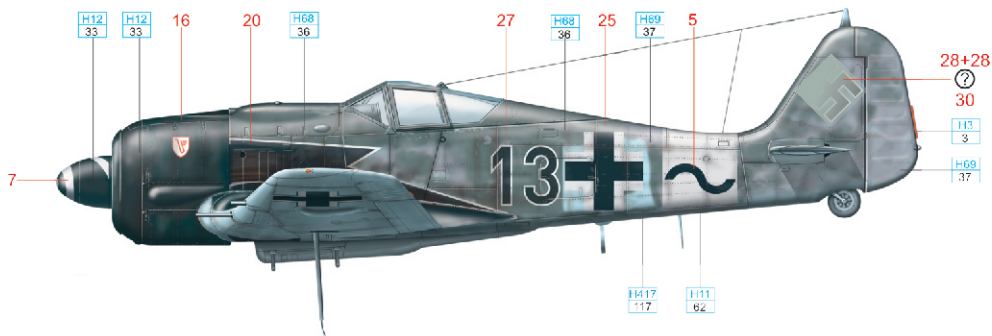

BLACK	H12 33	RED	H3 3	WHITE	H11 62
RLM 74	H88 36	RLM 75	H69 37	RLM 76	H417 117

B Paul Lixfeld, 6./JG 300, late 1944

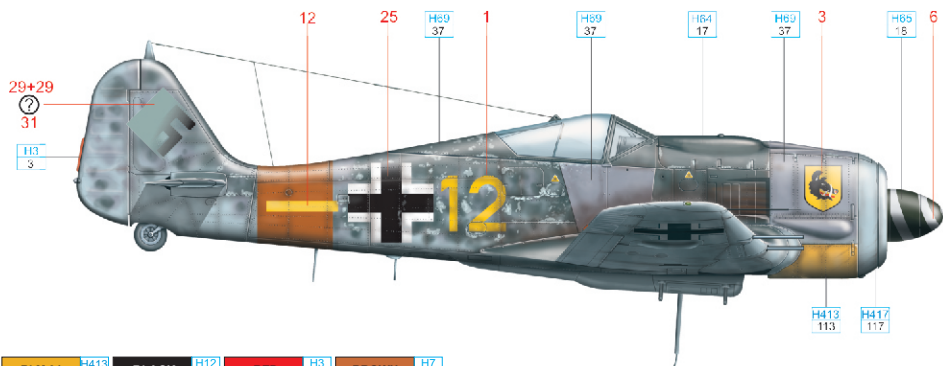
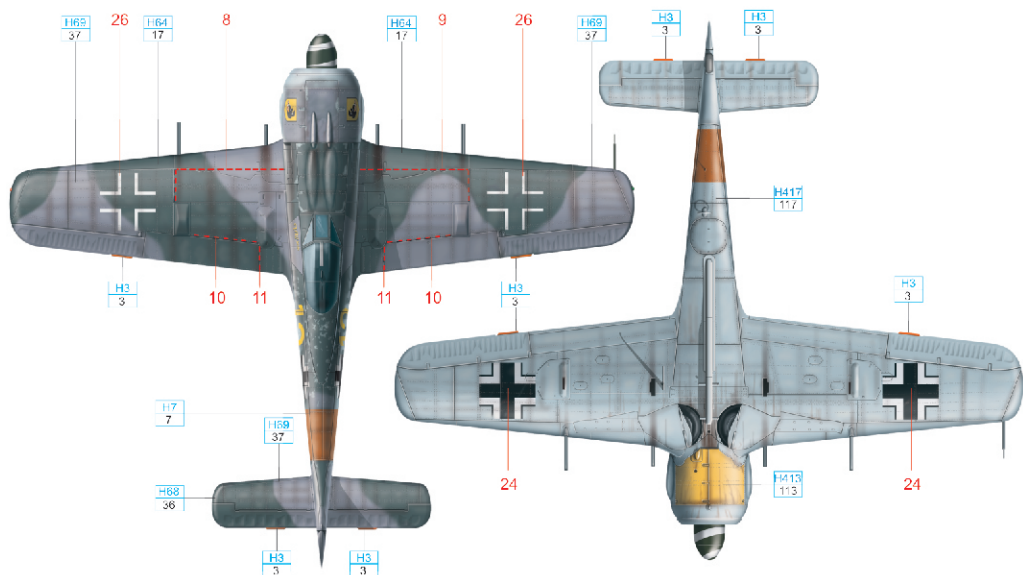
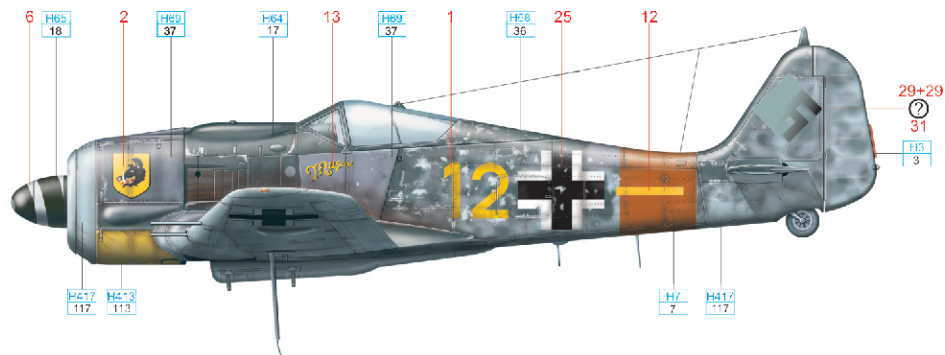

RLM 04	H413 113	BLACK	H12 33	RED	H3 3	BROWN	H7 7
RLM 71	H64 17	RLM 75	H69 37	RLM 76	H417 117	RLM 70	H65 18

