

GERMAN WWI RECONNAISSANCE AND BOMBER BIPLANE

1/48 SCALE PLASTIC KIT

ProfIPACK
edition

#8043



INTRO

When the new Roland C.II biplane reached the front lines in March 1916, they were the smallest, fastest and best climbing class "C" aircraft in German service. Although the Roland had the same 160 HP Mercedes D.III engine like other class "C" (armed, double seat, single engine biplanes) aircraft, its revolutionary streamlined design proved to be about 30 km/h faster than the others. This meant that the Roland was equal in speed with Nieuport 11s or Sopwith Pups, the best allied fighters at the time. Rolands served as long range reconnaissance, bomber and artillery observation aircraft in the front line for more than a year, until mid 1917. In late 1916 the Roland was successfully employed in a night bomber role. It was always a respectable opponent, for example the British ace Capt. Ball, who had shot down 17 Roland C.II's, said that the Roland was the best German fighting aircraft in 1916. The German pilots, however, were not so keen, and there were a lot of criticisms to the in-effective rudder, which limited the Roland's usage in dog-fights, and lack of the forward and downward vision which made landings very hazardous. Beyond these bars, the Roland C.II served to the late 1917, and still remains to be one of the best known World War One combat aircraft.

ÚVODEM

Když v březnu 1916 přišly k frontovým jednotkám nové dvouplošníky Roland C.II, byly to nejmenší, nejrychlejší a nejlépe stoupající stroje kategorie "C" (ozbrojené, dvousedadlové, jednomotorové dvouplošníky). Ačkoli byl Roland C.II poháněn stejným motorem Mercedes D.III o výkonu 160 k, jeho revoluční, aerodynamická konstrukce mu dovolila dosáhnout až o 30 km/h vyšší maximální rychlost než ostatním typům této kategorie. To znamená, že dosahoval srovnatelné maximální rychlosti jako Nieuport 11 nebo Sopwith Pup, dvě nejlepší spojenecké stíhačky té doby. Rolandy byly používány jako dálkové průzkumné, bombardovací a dělostřelecké pozorovací stroje, a na podzim 1916 byly úspěšně použity také jako noční bombardéry. Roland C.II byl vždy nebezpečný protivník, a například britské eso Capt. Albert Ball, který v roce 1916 sestřelil 17 Rolandů, považoval Roland C.II za tehdejší nejlepší německý bojový stroj. Ovšem, jak už to bývá, němečtí piloti nebyli až tak nadšeni. Na Rolandy se snažela vlna kritiky pro nedostatečnou účinnost malých ocasních ploch, což snižovalo jejich hodnotu v soubojích, a na nedostatečný výhled dopředu a dolů, což činilo přistání s Rolandem vždy nebezpečným manévrem. Přes tyto výhrady sloužil Roland C.II v první linii dlouho do roku 1917, a až do dnešních dnů zůstává jedním z nejnámějších bojových letadel První světové války.

ATTENTION



UPOZORNĚNÍ



ACHTUNG



ATTENTION



注意



Carefully read instruction sheet before assembling. When you use glue or paint, do not use near open flame and use in well ventilated room. Keep out of reach of small children. Children must not be allowed to suck any part, or pull vinyl bag over the head.



Před započatím stavby si pečlivě prostudujte stavební návod. Při používání barev a lepidel pracujte v době větrané místnosti. Lepidla ani barvy nepoužívejte v blízkosti otevřeného ohně. Model není určen malým dětem, mohlo by dojít k požití drobných dílů.

INSTRUCTION SIGNS * INSTR. SYMBOL * INSTRUKTION SINNBILDEN * SYMBOLES * 記号の説明

OPTIONAL
VOLBABEND
OHNOUTOPEN HOLE
VYVRTAT OTVORSYMETRICAL ASSEMBLY
SYMETRICKÁ MONTÁŽREMOVE
ODŘÍZNOUTREVERSE SIDE
OTOČIT

PARTS



DÍLY



TEILE



PIÈCES



部品

PLASTIC PARTS

A>

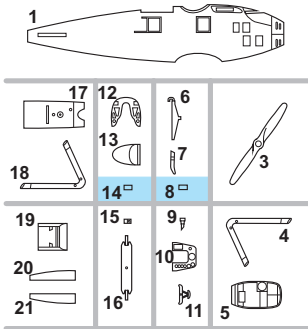

B>

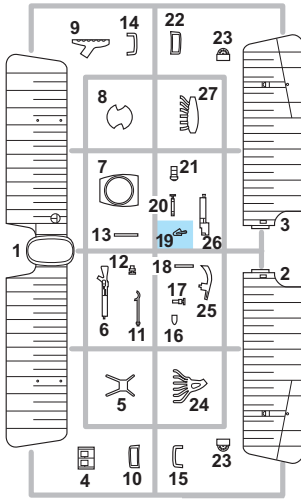

C>

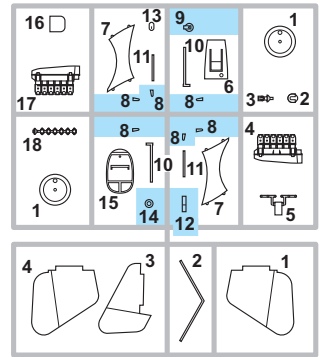

F>

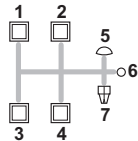
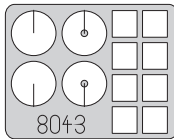
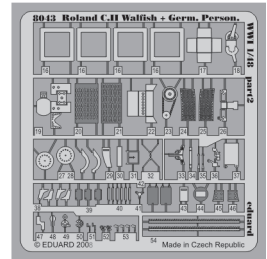
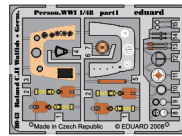
eduard
MASKPE - PHOTO ETCHED
DETAIL PARTS

-Parts not for use. -Teile werden nicht verwendet. -Pièces à ne pas utiliser. -Tyto díly nepoužívejte při stavbě. - 使用しない部品

COLOURS



BARVY



FARBEN



PEINTURE



色

| GSI Colors (GUNZE) | | |
|--------------------|-----------|------------|
| AQUEOUS | Mr. COLOR | |
| [R11] | C8 | SILVER |
| [R11L] | C62 | WHITE |
| [R12] | C33 | BLACK |
| [R12L] | C43 | WOOD BROWN |
| [R13] | C40 | VIOLET |
| [R13L] | C41 | RED BROWN |
| [R133] | C13 | GRAY |
| [R30] | C303 | GREEN |
| [R33] | C338 | LIGHT GRAY |

| AQUEOUS | Mr. COLOR | |
|--------------------------|-----------|-------------------|
| [R24] | [] | RUST |
| [R17] | C117 | LIGHT GRAY |
| [R23] | C123 | DARK GREEN |
| Mr. METAL COLOR | | |
| [R214] | [] | DARK IRON |
| [R218] | [] | ALUMINIUM |
| [R219] | [] | BRASS |
| Mr. COLOR SUPER METALLIC | | |
| [R01] | [] | SUPER FINE SILVER |

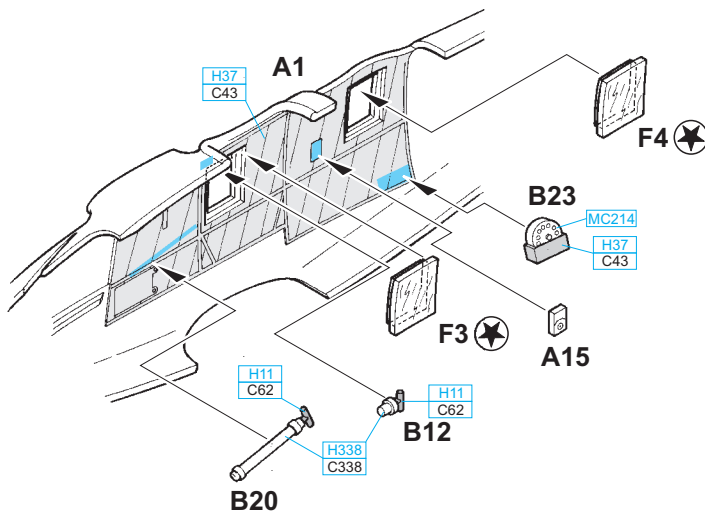
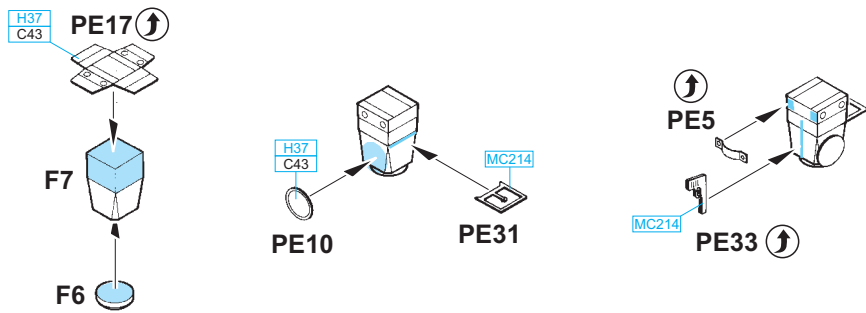
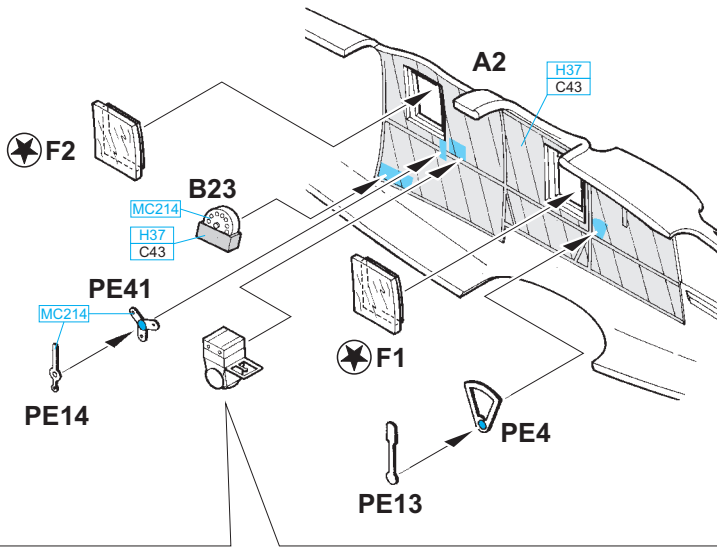

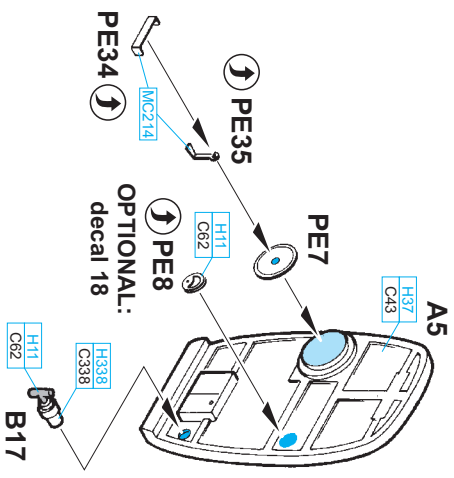
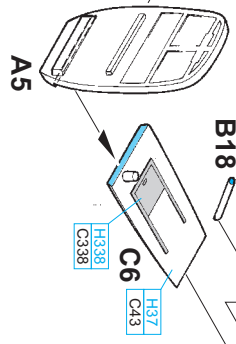
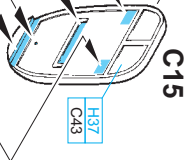
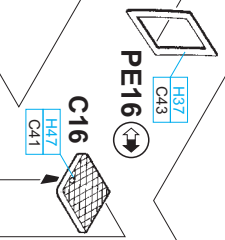
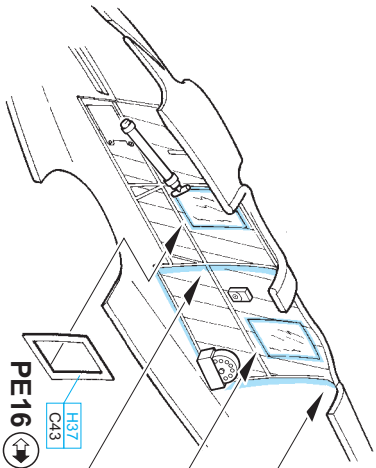

A 

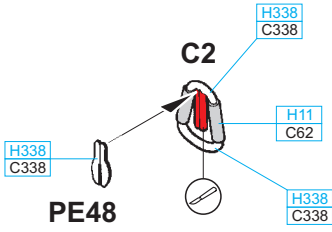

B

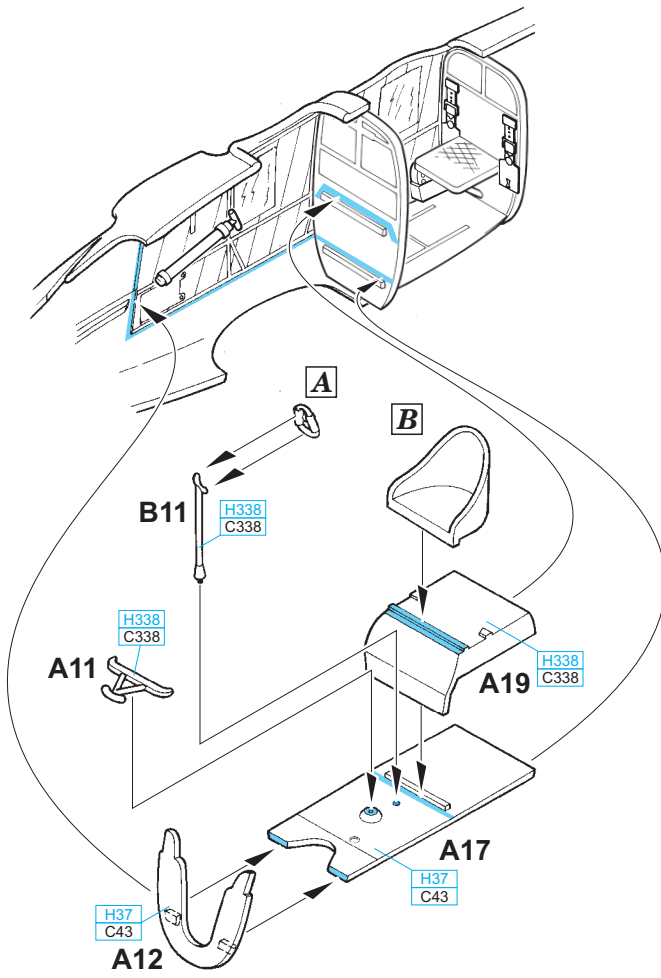
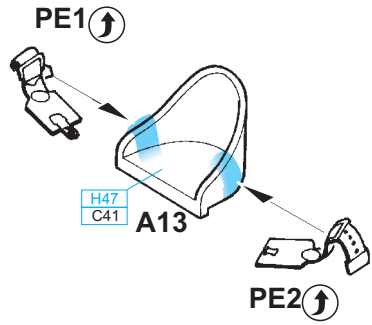

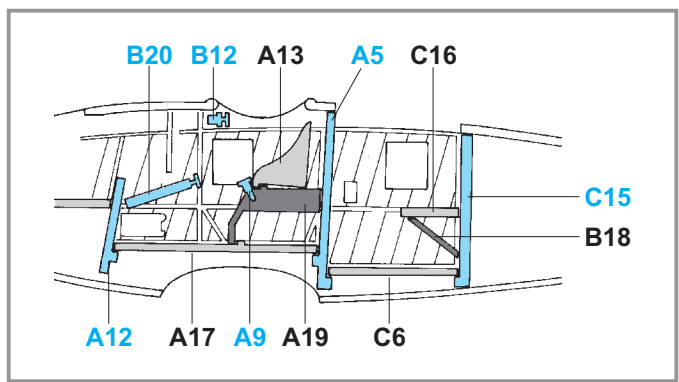
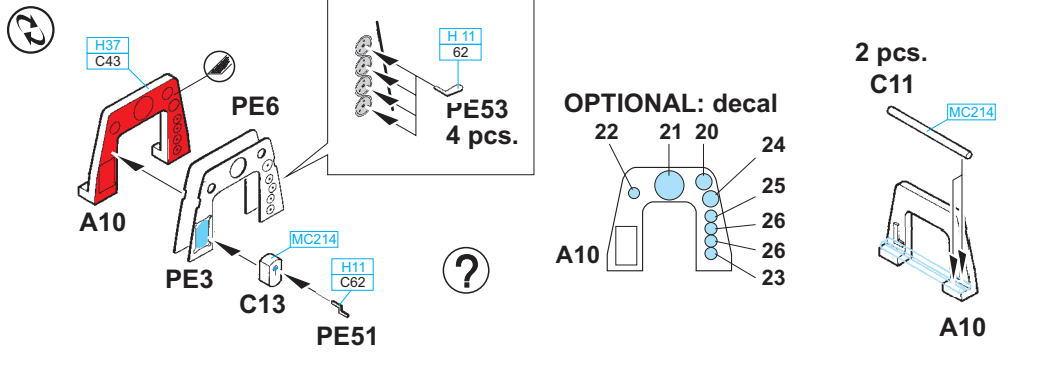
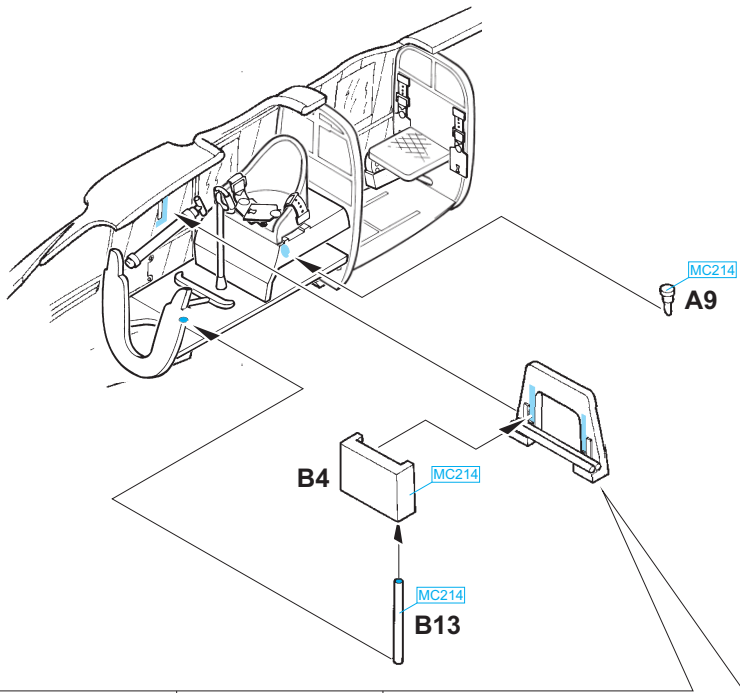

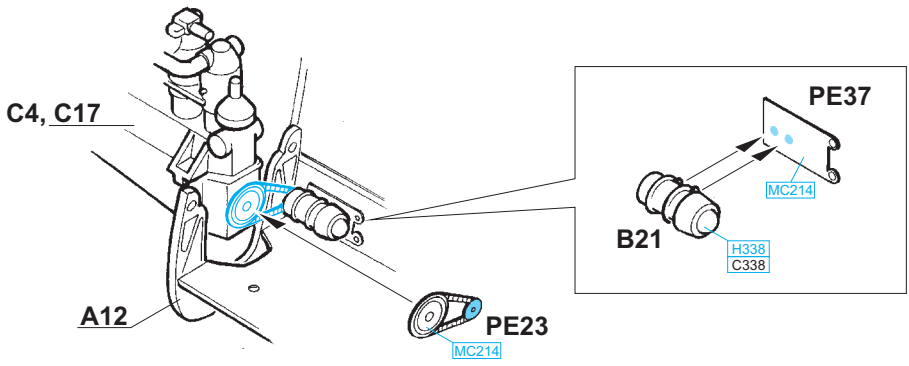
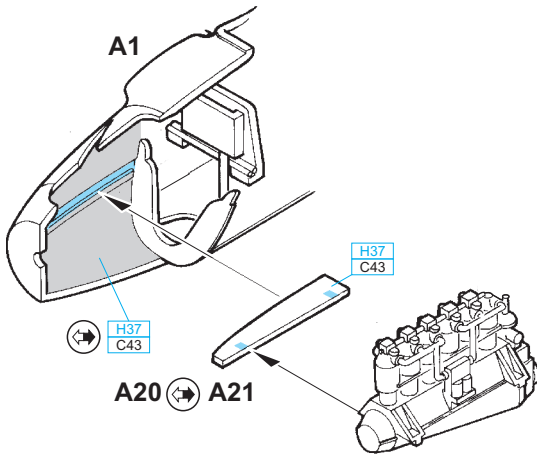
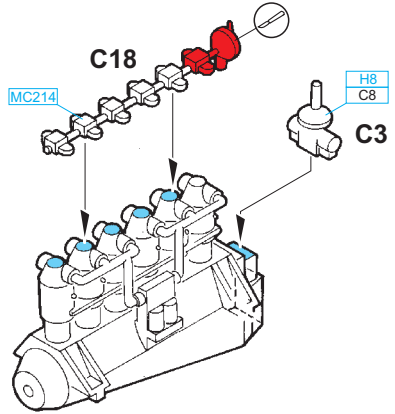
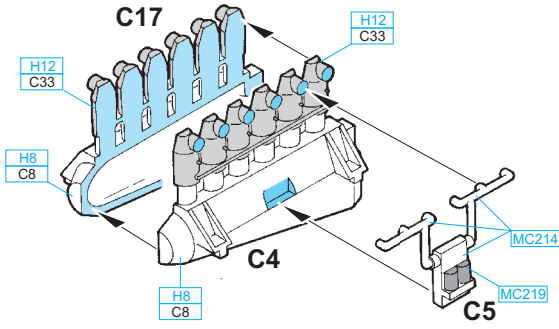

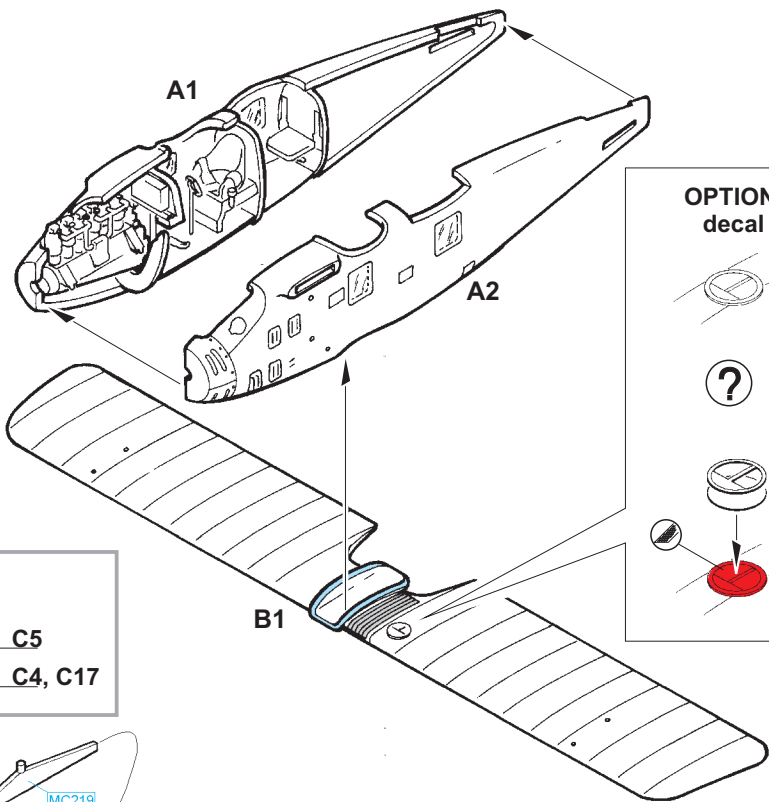

**OPTIONAL:
decal 17**

B1

?

PE12

PE11

B1

A6

C5

C4, C17

A6

MC219

45°

A1 → A2

C1 2 pcs.

C1 2 pcs.

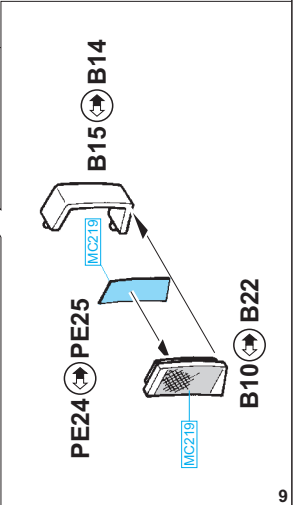
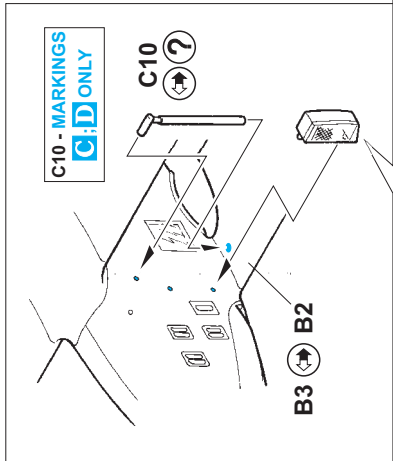
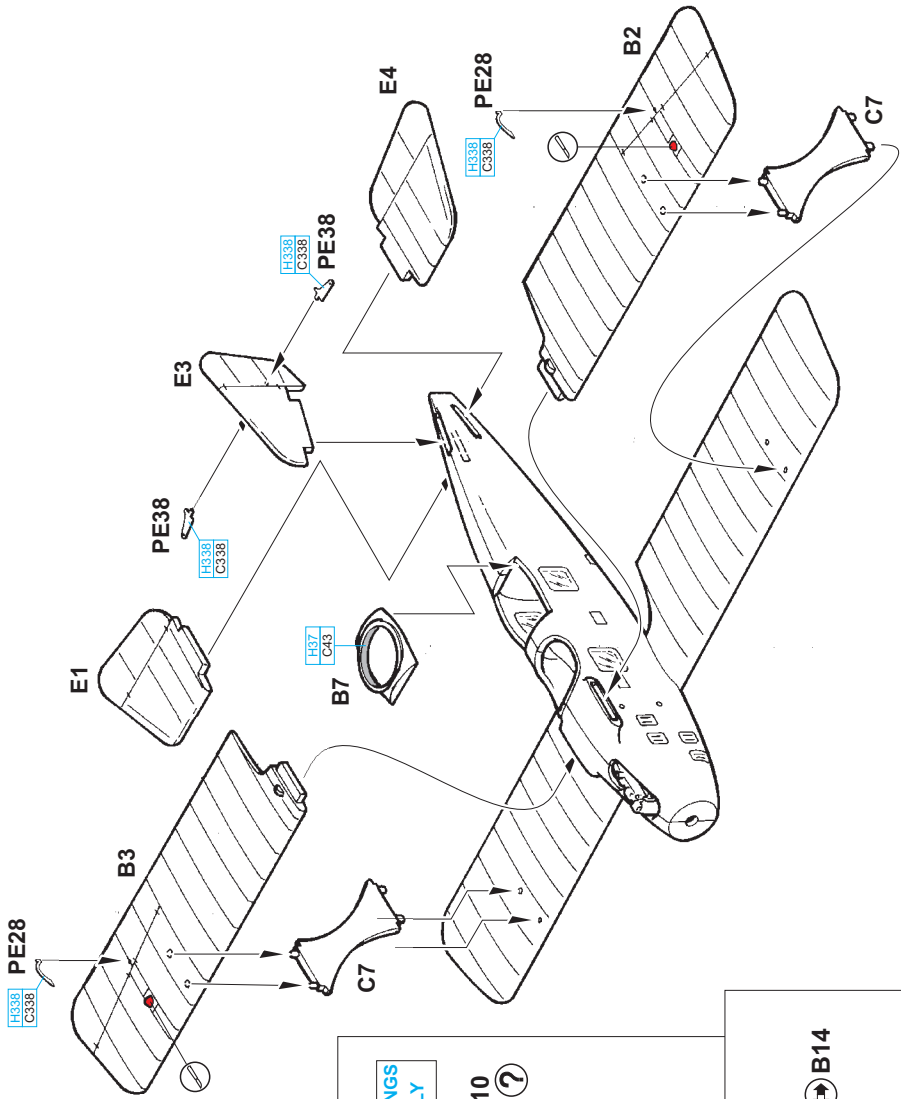

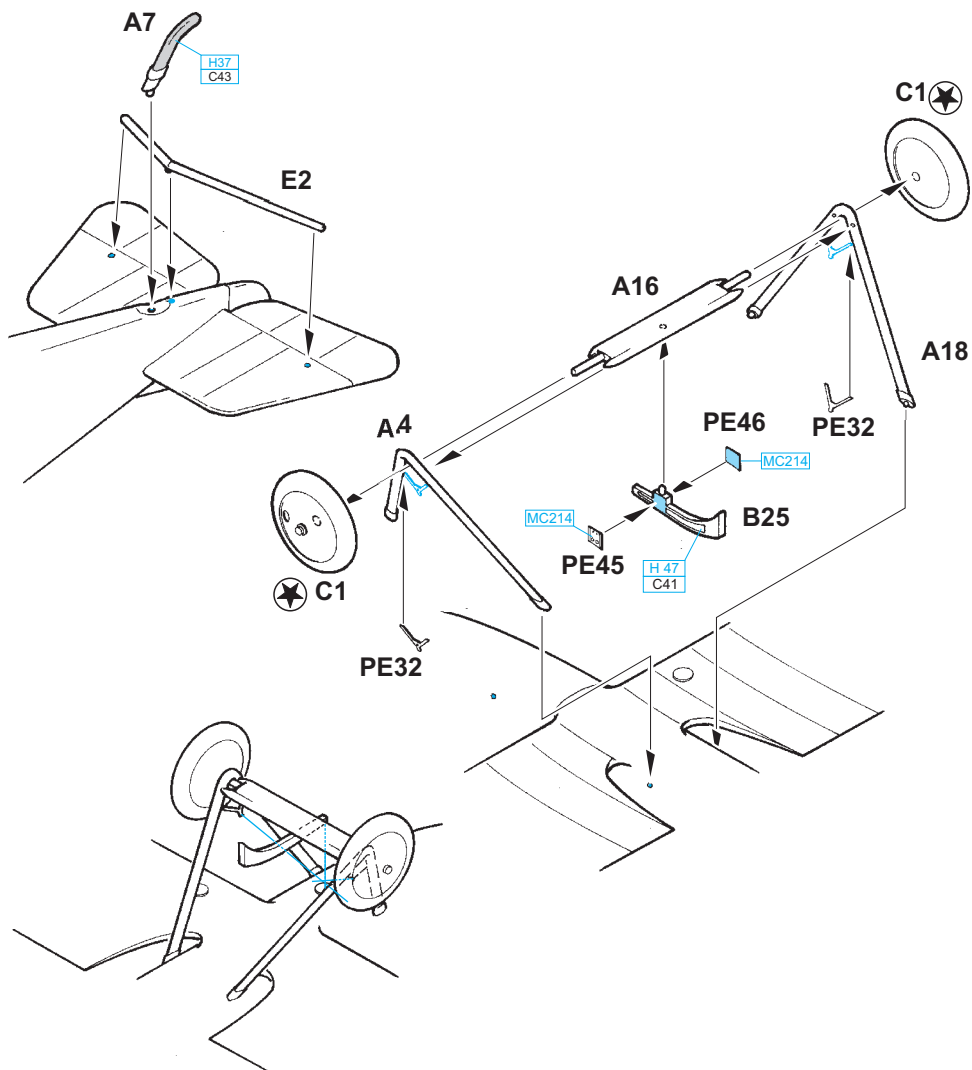

C MARKINGS **A**; **B**; **C** ONLY

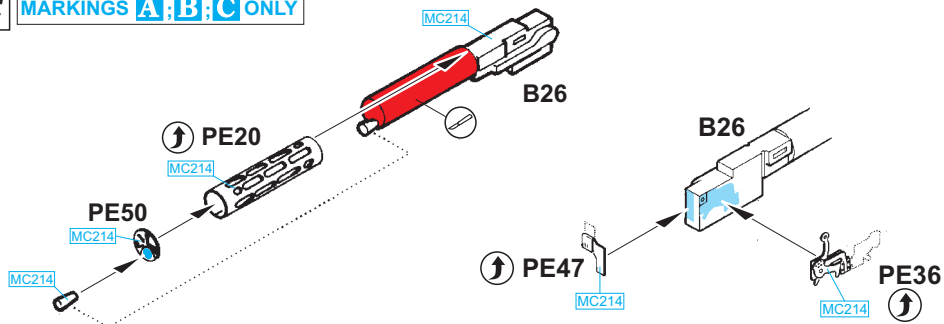

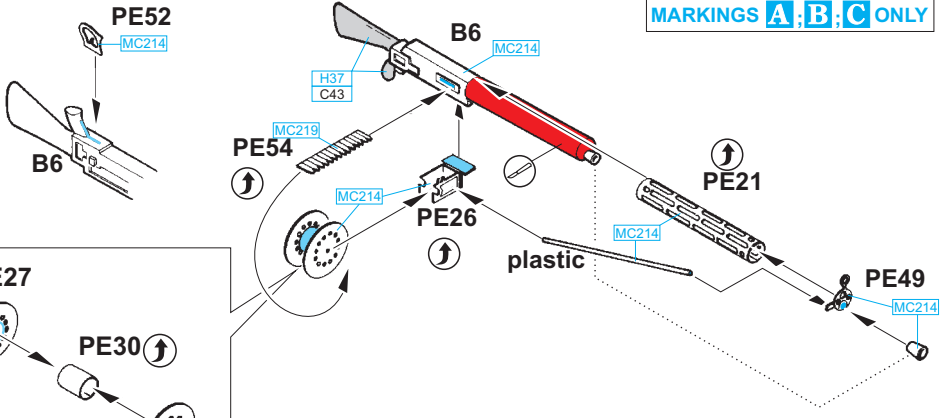
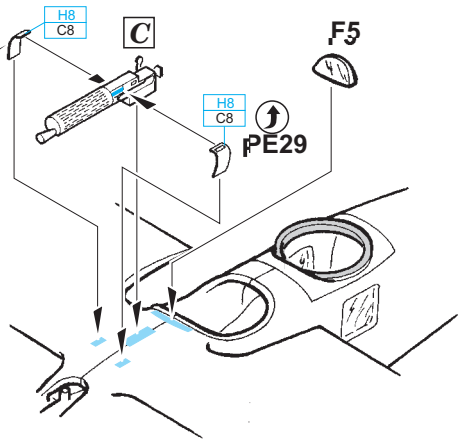
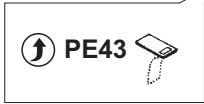
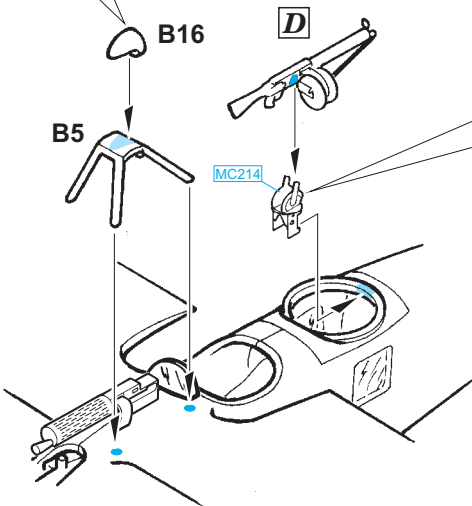
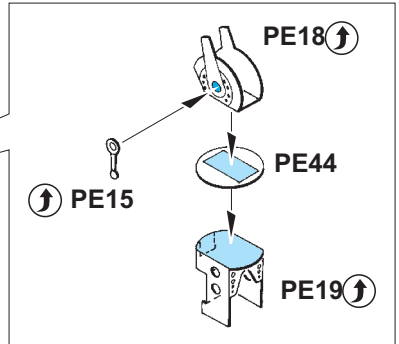
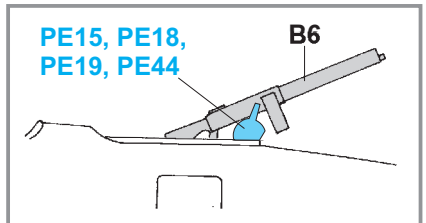
D**MARKINGS A; B; C ONLY****PE27****PE30** (up arrow)**PE27****PE43** (up arrow)**B16****PE9** (up arrow)**OPTIONAL: decal 19****B16****D****B5****MC214****PE18** (up arrow)**PE44****PE19** (up arrow)**PE15** (up arrow)**PE15, PE18, PE19, PE44****B6**

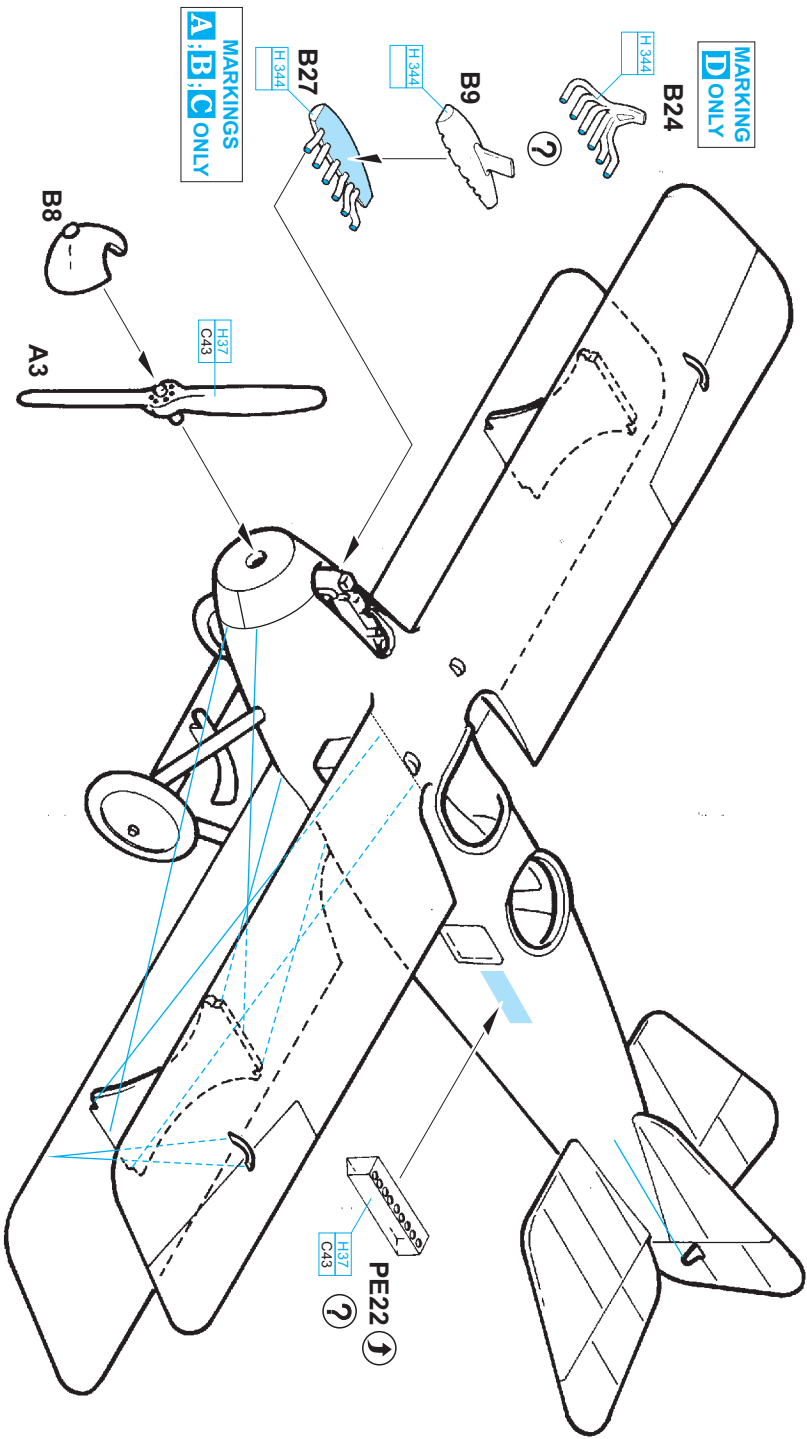

A Lt. Seibert a Hptm. Pflieger, FFA 5b, západní fronta, podzim 1916

S tímto strojem létala osádka Lt. Seibert (pilot) a Hptm. Pflieger (pozorovatel) nad západní frontou na podzim roku 1916. Letci byli příslušníky Feldfliegerabteilung Nr.5 b (FFA 5b). Trup nesl motiv znázorňující rybí šupiny, na přední doplňný o tlamu a oči.

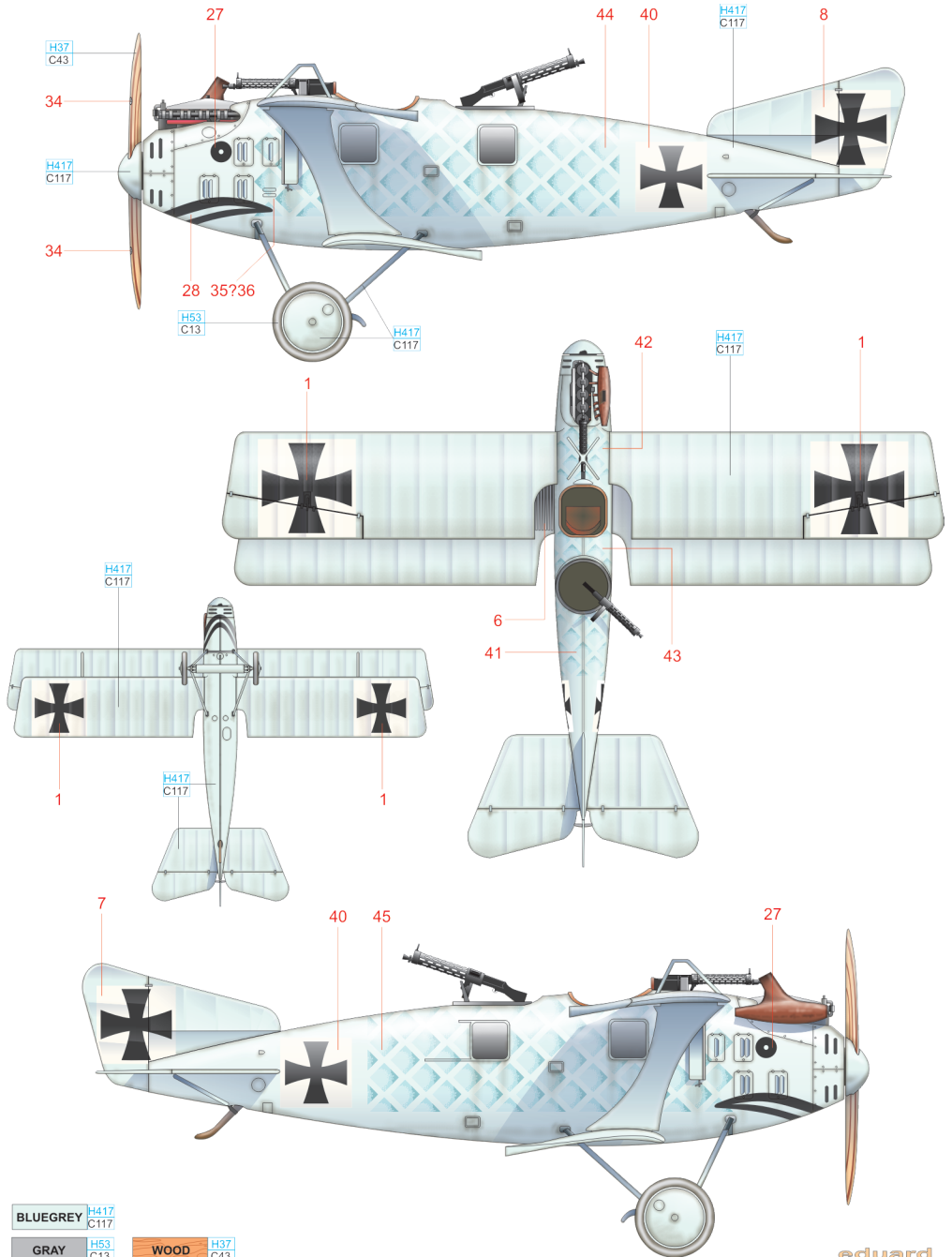

B západní fronta, léto 1917

Tento Roland C.II byl používán jednou z německých jednotek působících nad západní frontou. Rolandy C.II sloužily v německém letectvu v roli průzkumných letounů, případně jako doprovodné stíhačky.

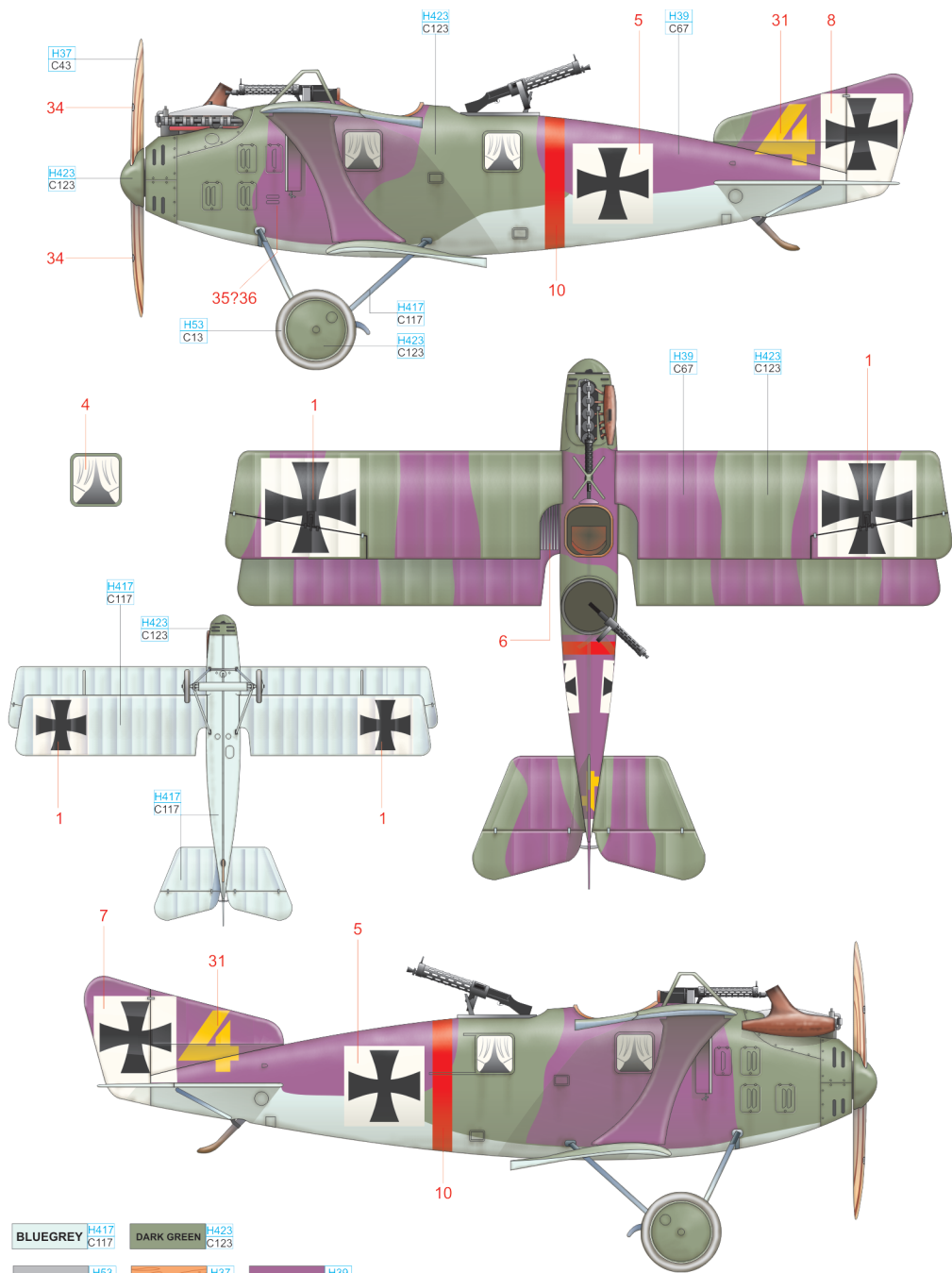

C Kasta 2, Kagohl 1, přelom roku 1916/1917

Tento letoun byl používán piloty Kampffgeschwader der Obersten Heeresleitung 1 – Kagohl 1 na západní frontě. V dubnu 1917 byla tato jednotka přejmenována na Bombengeschwader der Obersten Heeresleitung 1, zkrátčeně Bogohl 1.

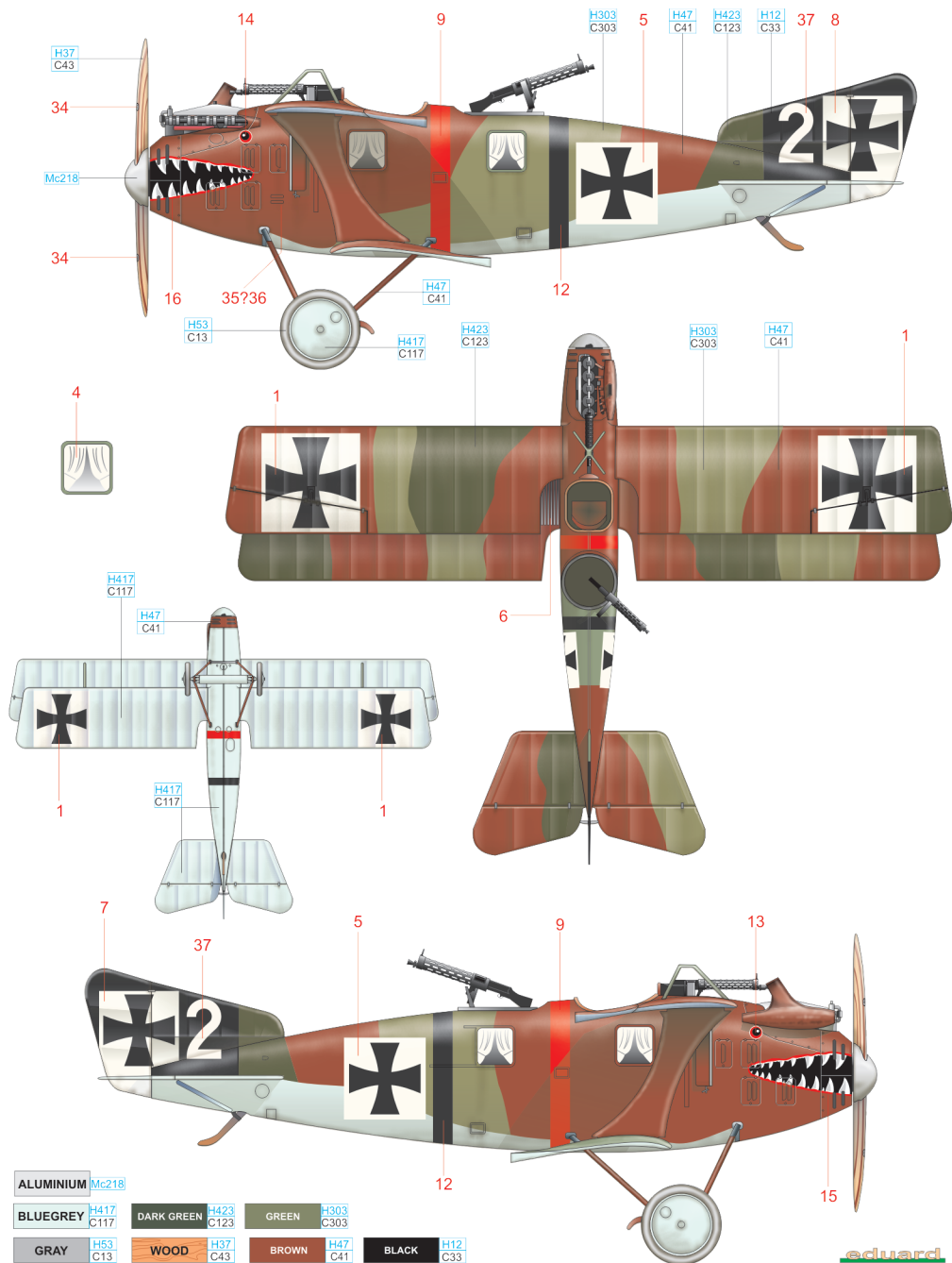

D 1859/16, Bayerische Flieger Schule 5, 1917

V roce 1917 používala tento Roland C.II školní jednotka Bayerische Flieger Schule 5. Z letounů tohoto útvaru byly demontovány zbraně s oběžným kruhem a do kokpitu pozorovatele byly pro imitaci zátěže umístěny pytle s pískem. Toto řešení mělo zabránit posunu těžiště letounu.

