

SOVIET WWII FIGHTER

1:48 SCALE PLASTIC KIT



eduard

ProfiPACK



INTRODUCTION

The Yak-3 was the best fighter Yakovlev produced during WW 2 and there is no doubt that, together with Lavochkin La-7, it was the best Russian fighter of the WW 2 period, the real Russian ace maker. The successful Yak-'s wooden airframe was lightened and fitted with a new WK 105 PF engine (1240 HP) in 1943. The early series aircraft, with one 20mm ShVAK canon and one 12,7 mm UBS machine gun (late production aircraft had two UBS guns), it reached the front lines in June 1944. Although it was a typical Russian "wooden" aircraft, with spartan cockpit and poor radio and navigation equipment, the Yak-3 was an excellent front line combat fighter, extremely maneuverable, and with a very good rate of climb and speed (646 km/h at 4100 m). Up to 5000 m, where most dog-fights on the eastern front occurred, the Yak-3 was tough opponent to all German fighters and especially the experienced guards pilots got many kills with their Yak-3s. In total 4848 Yak-3s were produced, with 4111 being built before the war ended.

wing span	9,20m	max. speed	646km/hod / at 4100m
length	8,50m	normal range	648km
take-off weight	2692kg	engine	Klimov VK-105PF 1240 HP
max. speed	567km/hod	armament	1x ShVAK 20mm, 2x UBS 12,7mm

ÚVOD

Jak -3 byla nejlepší Jakovlevova stíhačka vyráběná za 2.sv.války a bezesporu to byla, spolu s Lavočkinem La-7, nejlepší ruská stíhačka 2.sv.války vůbec, skutečný ruský tvůrce es. Úspěšný dřevěný drak Jaku-1 byl v roce 1943 odlehčen a doplněn novým motorem VK 105 PF o výkonu 1240 k. První sériové stroje, vyzbrojené jedním kanónem ŠVAK ráže 20 mm a jedním kulometem ráže 12,7 mm, přišly na frontu v červnu 1944. Ačkoli to bylo typické ruské "dřevěné" letadlo, se spartánsky vybaveným pilotním prostorem a chudým rádiovým a navigačním vybavením, Jak-3 byla vynikající frontová souborová stíhačka, extrémně obratná, s dobrou stoupavostí a rychlostí (646 km/hod v 4100 m). Většina sériových letadel měla zesílenou výzbroj jednoho 20 mm kanónu a dvou 12,7 mm kulometů. V bojové hladině do 5000 m byl Jak-3 tvrdým soupeřem pro všechny německé stíhačky, a především zkušení gardovní piloti na nich dosahovali řady sestřelů. Celkem bylo postaveno 4848 Jaků-3, z toho za války 4111.

rozpětí	9,20m	max.rychlost v 4100m	646km/hod
délka	8,50m	dolet	648km
vzletová hmotnost	2692kg	motor	Klimov VK-105PF 1240 HP
max.rychlost při zemi	567km/hod	výzbroj	1x ŠVAK 20mm, 2x UBS 12,7mm

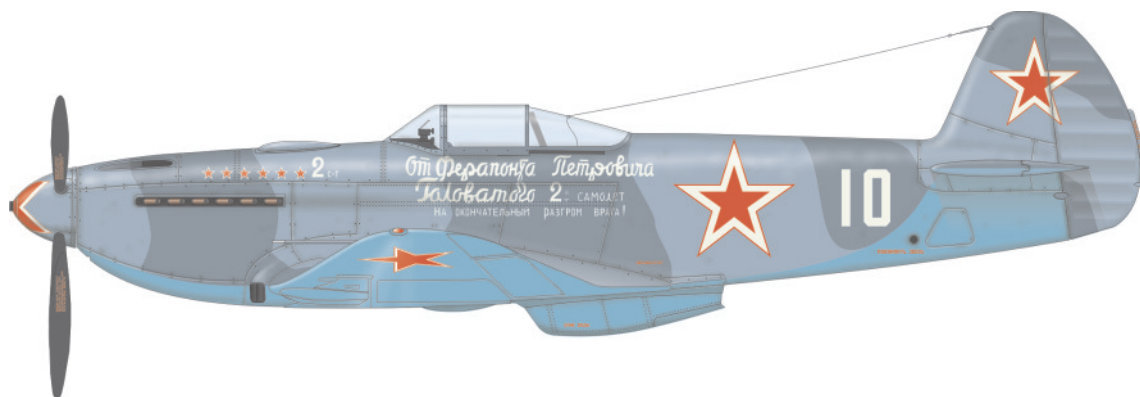



- (GB)** Carefully read instruction sheet before assembling. When you use glue or paint, do not use near open flame and use in well ventilated room. Keep out of reach of small children. Children must not be allowed to suck any part, or pull vinyl bag over the head.
- (CZ)** Před započatím stavby si pečlivě prostudujte stavební návod. Při používání barev a lepidel pracujte v dobře větrané místnosti. Lepidla ani barvy nepoužívejte v blízkosti otevřeného ohně. Model není určen malým dětem, mohlo by dojít k požití drobných dílů.
- (F)** Lire soigneusement la fiche d'instructions avant d'assembler. Ne pas utiliser de colle ou de peinture à proximité d'une flamme nue, et aérer la pièce de temps en temps. Garder hors de portée des enfants en bas âge. Ne pas laisser les enfants mettre en bouche ou sucer les pièces, ou passer un sachet vinyl sur la tête.
- (D)** Von dem Zusammensetzen die Bauanleitung gut durchlesen. Kleber und Farbe nicht nahe von offenem Feuer verwenden und das Fenster von Zeit zu Zeit Belüftung öffnen. Bausatz von kleinen Kindern fernhalten. Verhüten Sie, daß Kinder irgendwelche Bauteile in den Mund nehmen oder Plastiktüten über den Kopf ziehen.
- (JP)** 組み立てる前に必ず説明書をお読み下さい。接着剤や塗料をご使用の際は、窓を開けて十分な換気をおこない、火のそばでは使用しないで下さい。小さな子供の手の届かない所に必ず保管して下さい。部品や破片を噛んだり、なめたり、飲んだりすると大変危険です。又、部品を取り出した後のビニール袋は、小さな子供が頭から被ったりすると窒息する恐れがありますので、破り捨てして下さい。

INSTRUCTION SIGNS * INSTR. SYMBOL * INSTRUKTION SINNBILDEN * SYMBOLES * 記号の説明

- (?)** OPTIONAL
VOLBA
FACULTATIF
NACH BELIEBEN
選択する
- (↶)** BEND
OHNOUT
PLIER SIL VOUS PLAIT
BITTE BIEGEN
折る
- (⊘)** OPEN HOLE
VYVRTAT OTVOR
FAIRE UN TROU
OFFNEN
穴を開ける
- (↔)** SYMMETRICAL ASSEMBLY
SYMETRICKÁ MONTÁŽ
MONTAGE SYMÉTRIQUE
SYMMETRISCHE AUFBAU
左右均等に組み立てる
- (✂)** NOTCH
ZÁŘEZ
L INCISION
DER EINSCHNITT
切る
- (✂)** REMOVE
ODŘÍZNOUT
RETIRER
ENTFERNEN
移す
- (★)** APPLY EDUARD MASK
AND PAINT
POUŽIT EDUARD MASK
NABARVIT

PARTS



DÍLY



TEILE



PIÈCES



部品

PLASTIC PARTS

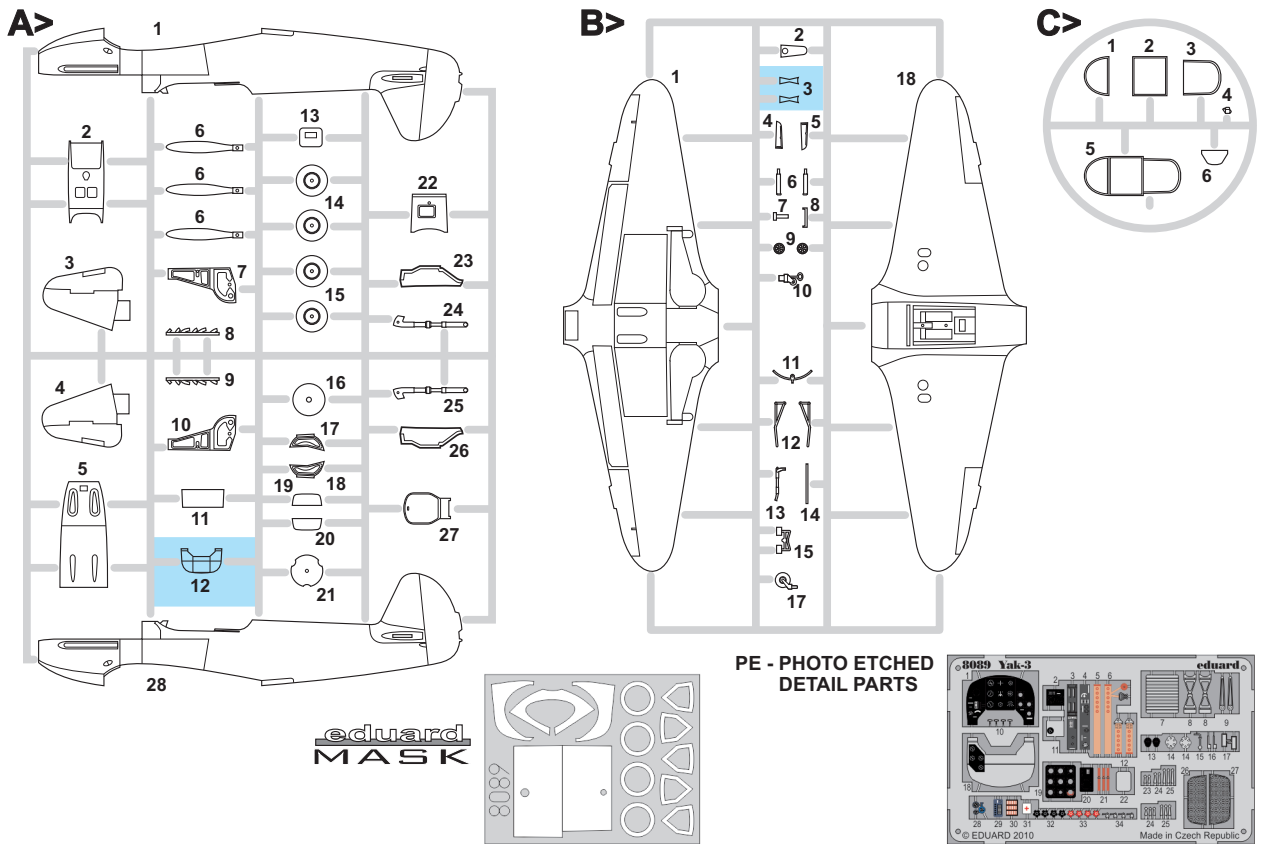

eduard
MASK

PE - PHOTO ETCHED
DETAIL PARTS

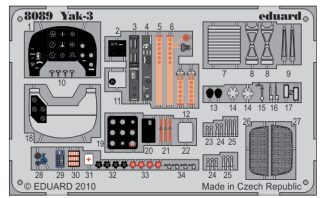

-Parts not for use. -Teile werden nicht verwendet. -Pièces à ne pas utiliser. -Tyto díly nepoužívejte při stavbě. -使用しない部品

COLOURS



BARVY



FARBEN



PEINTURE



色

GSI Creos (GUNZE)		
AQUEOUS	Mr.COLOR	
H 4	C4	YELLOW
H 5	C5	BLUE
H 6	C6	GREEN
H 11	C62	FLAT WHITE
H 12	C33	FLAT BLACK
H 13	C3	FLAT RED
H 37	C43	WOOD BROWN
H 48	C52	FIELD GRAY
H 47	C41	RED BROWN
H 77	C137	TIRE BLACK
H 85	C45	SAIL COLOR

AQUEOUS	Mr.COLOR	
H 317	C317	GRAY
H 323	C323	LIGHT BLUE
H 331	C331	DARK SEAGRAY
H 344		RUST
	C97	LIGHT GRAY
Mr.METAL COLOR		
	MC213	STEEL
	MC214	DARK IRON
	MC218	ALUMINIUM
Mr.COLOR SUPER METALLIC		
	SM01	SUPER CHROME

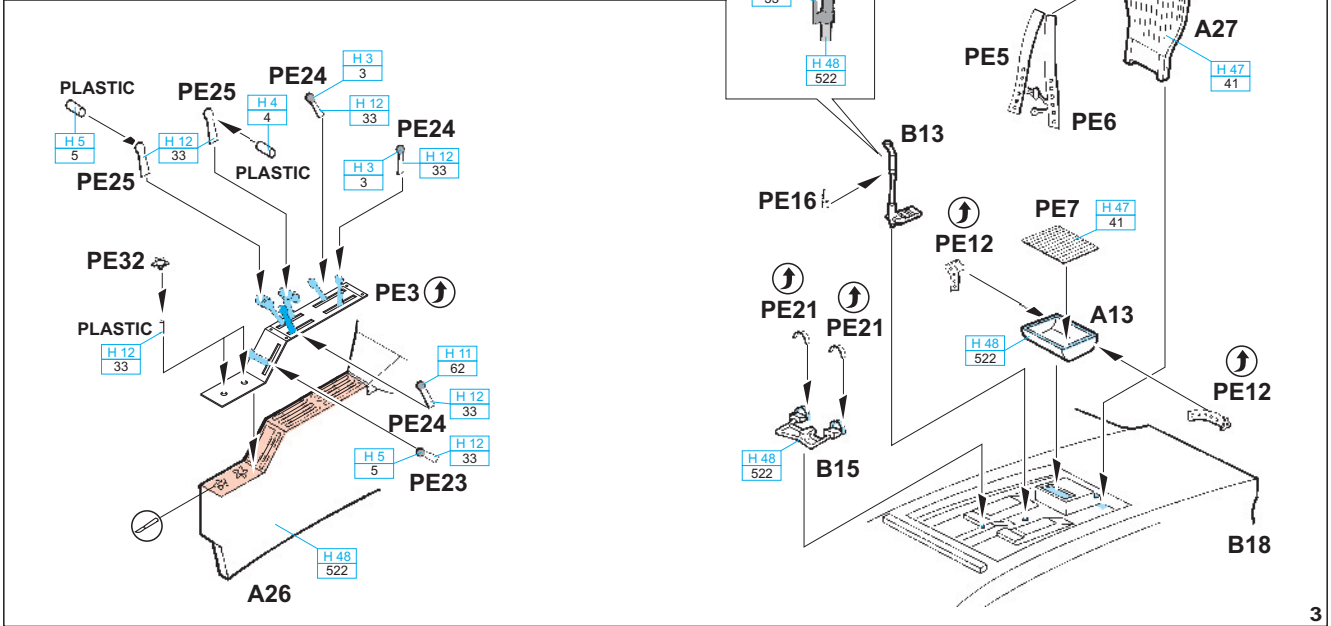
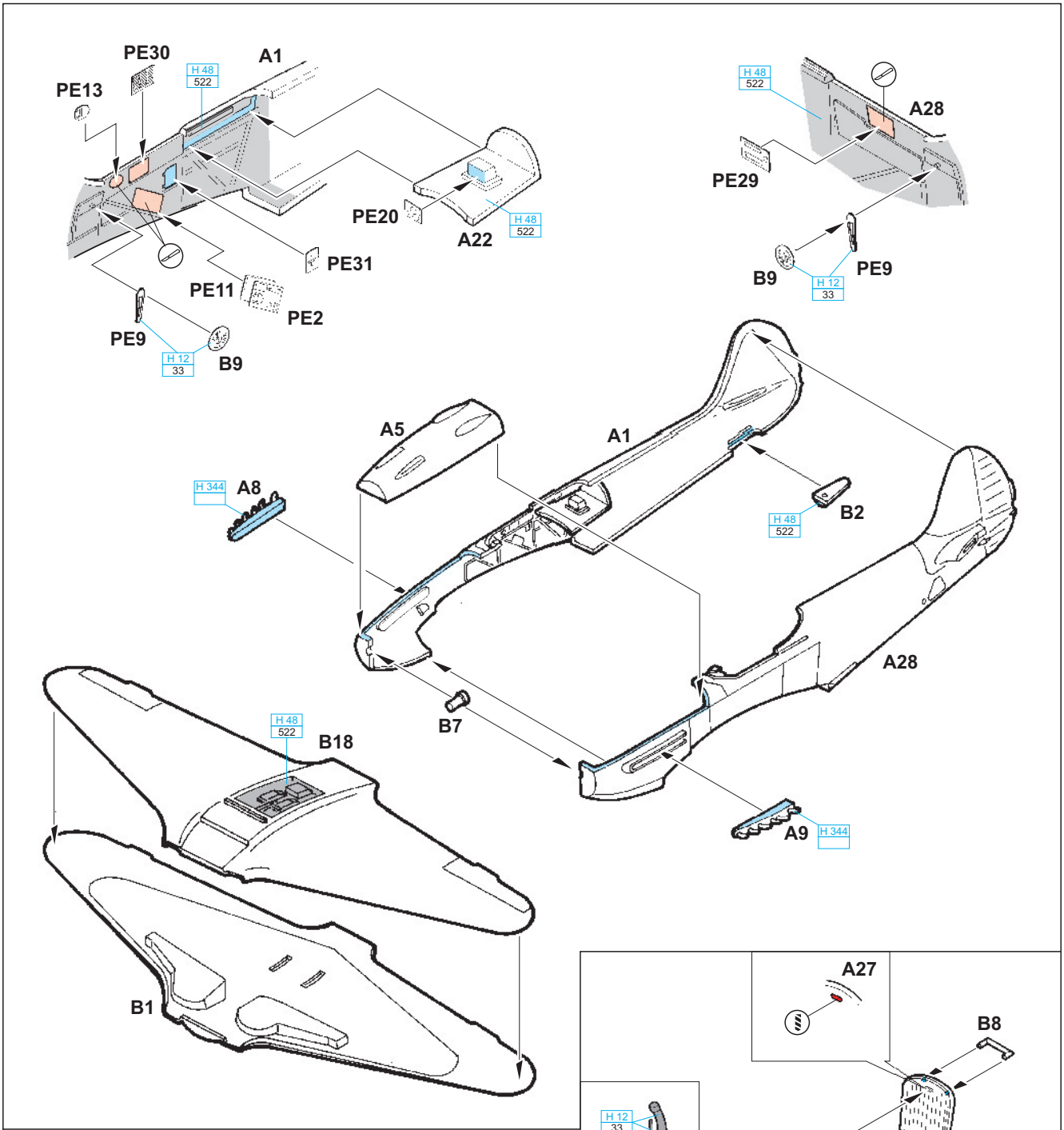

A23, A26



B18

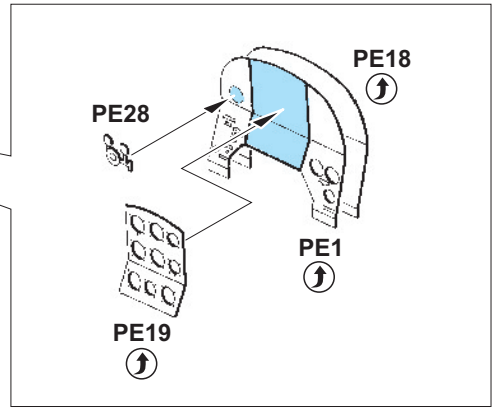
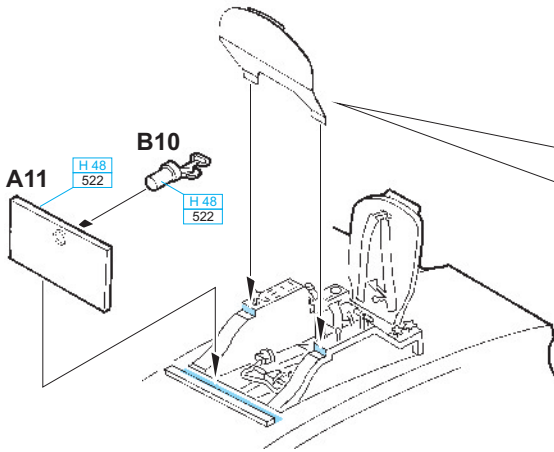
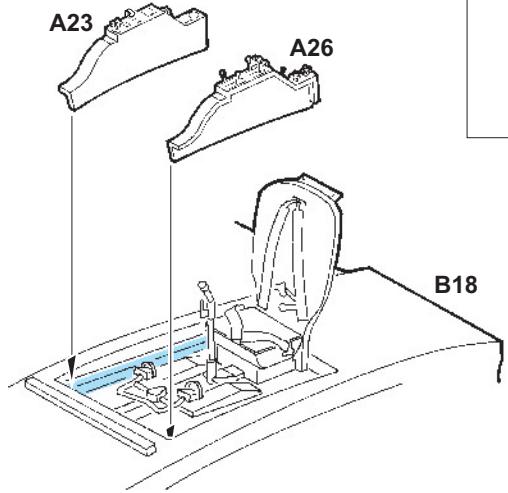
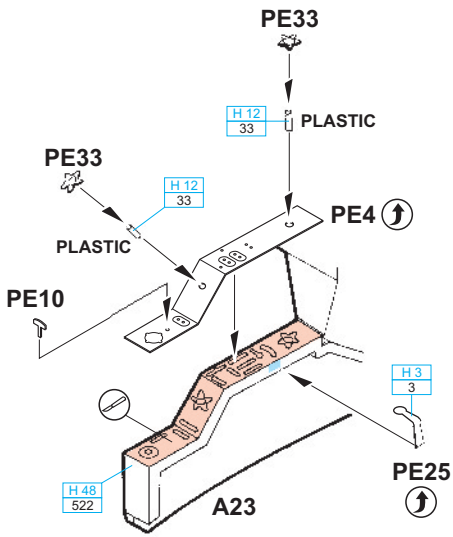

LEFT SIDE

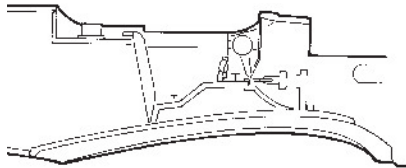

RIGHT SIDE

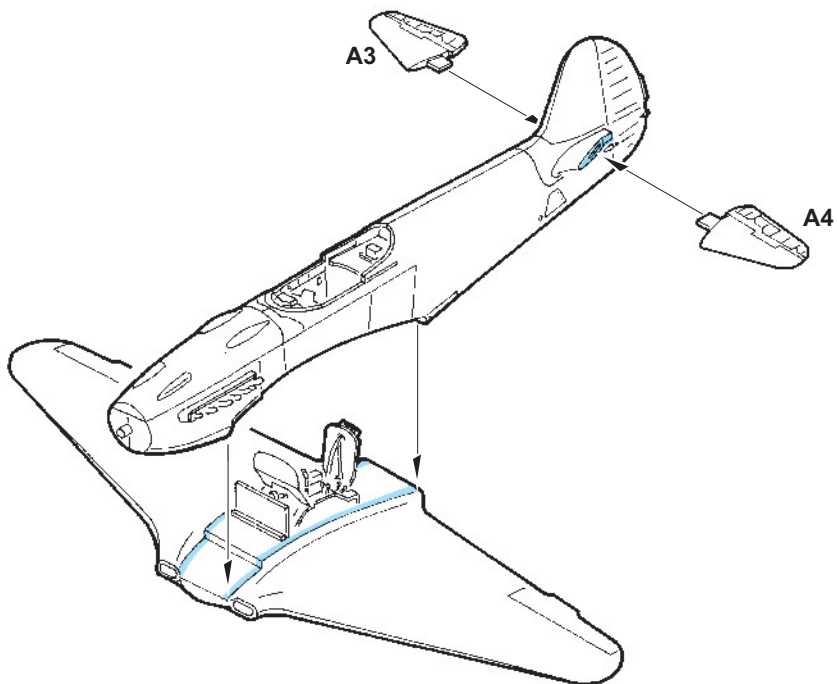
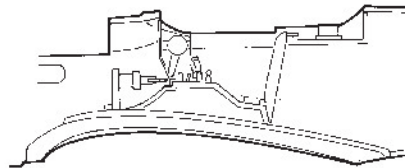

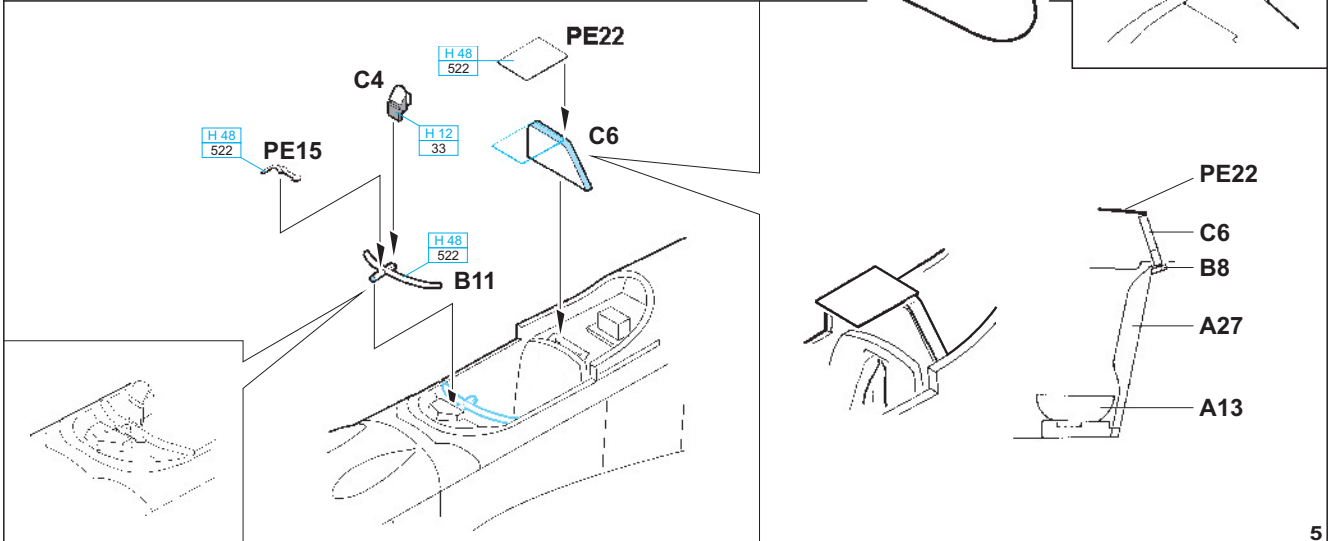
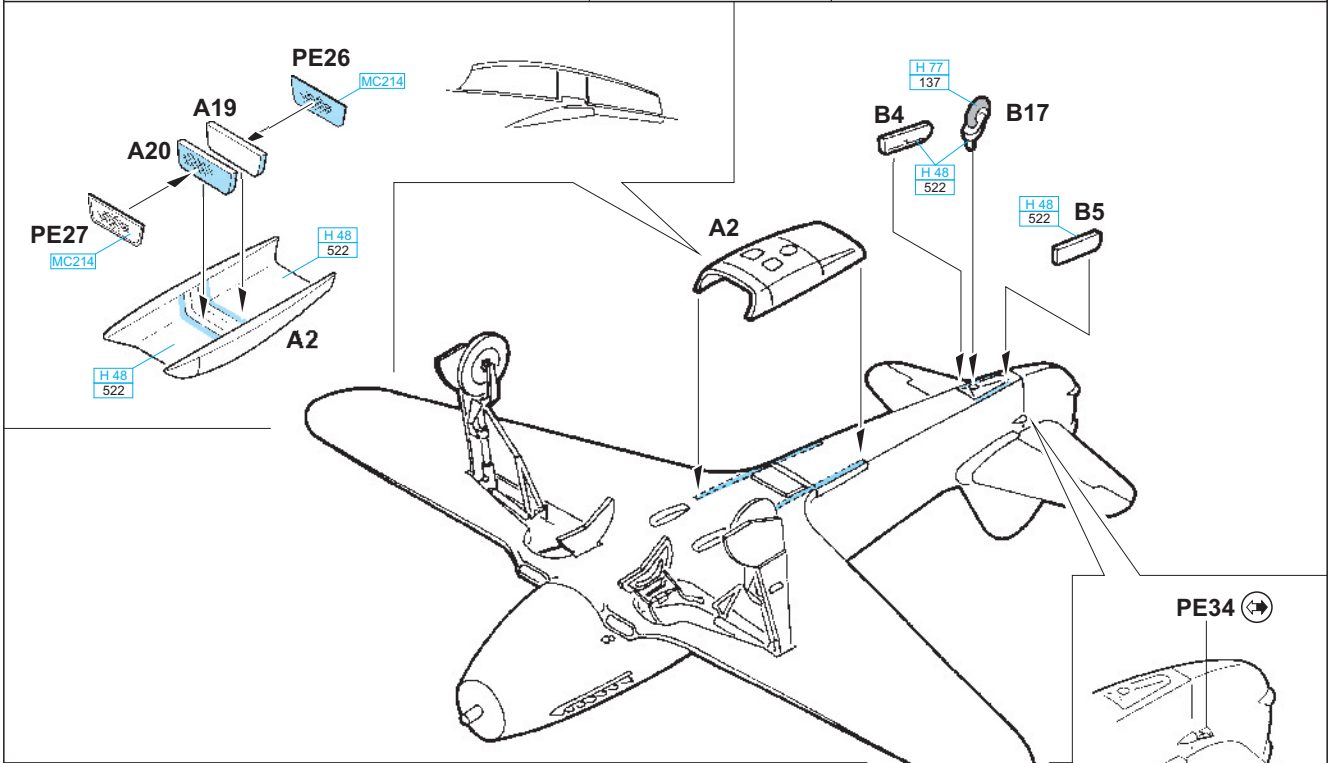
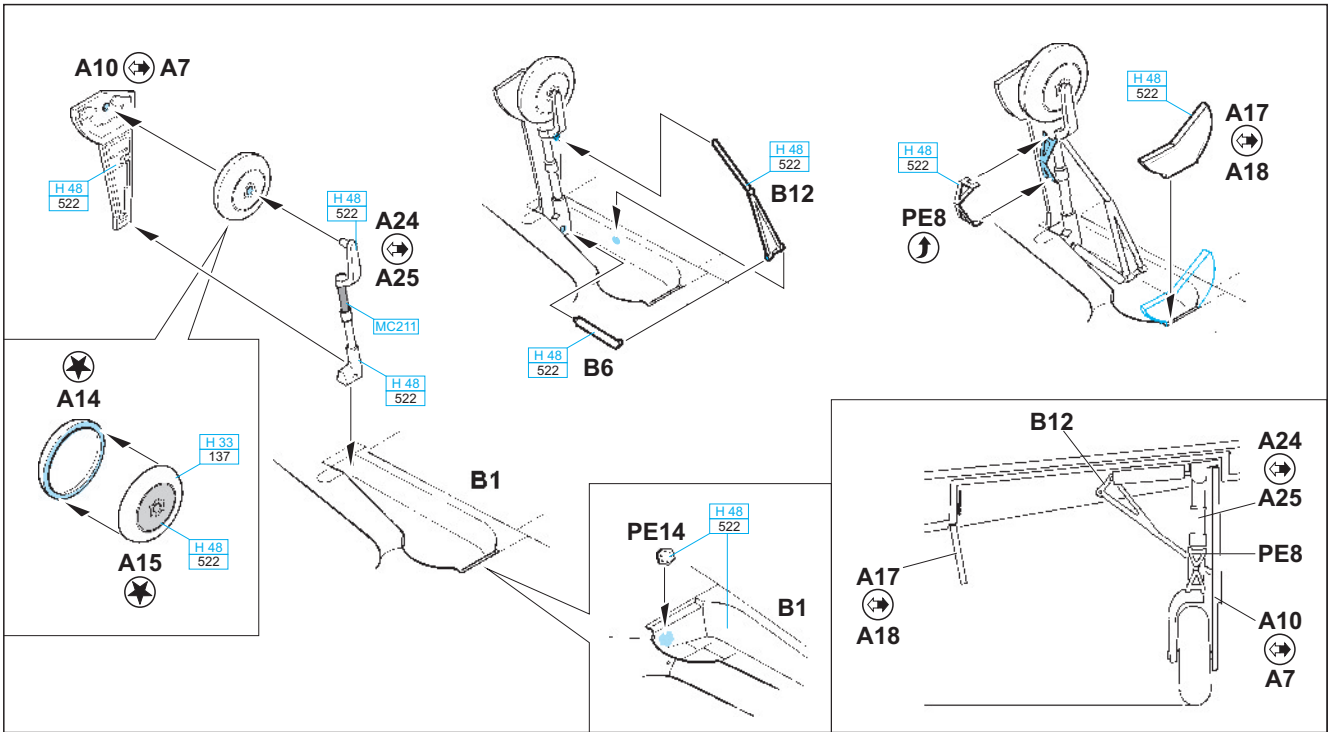

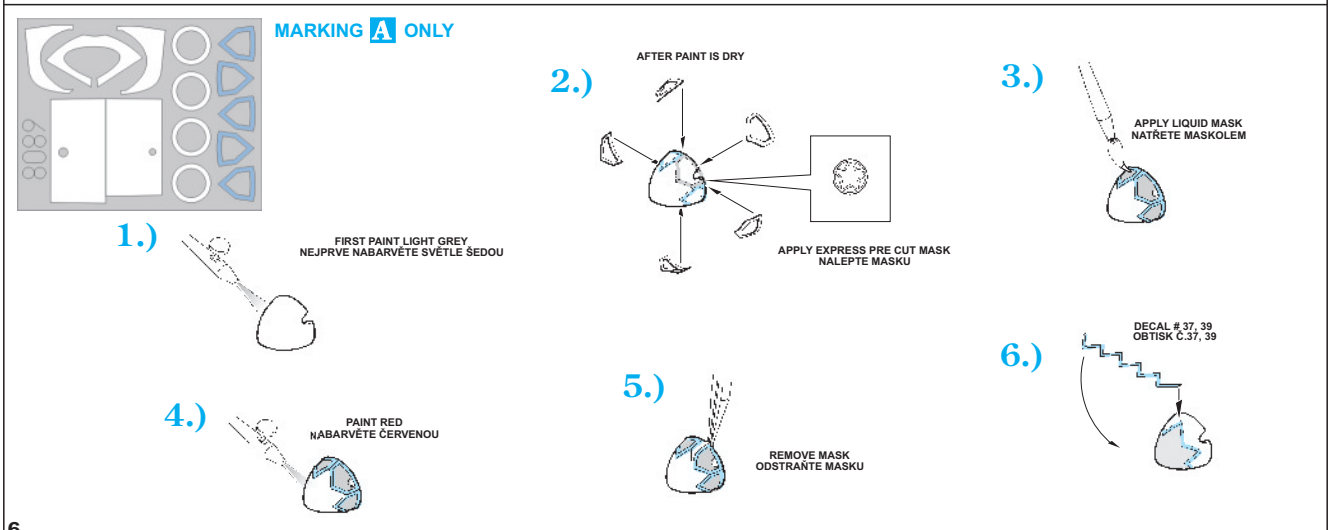
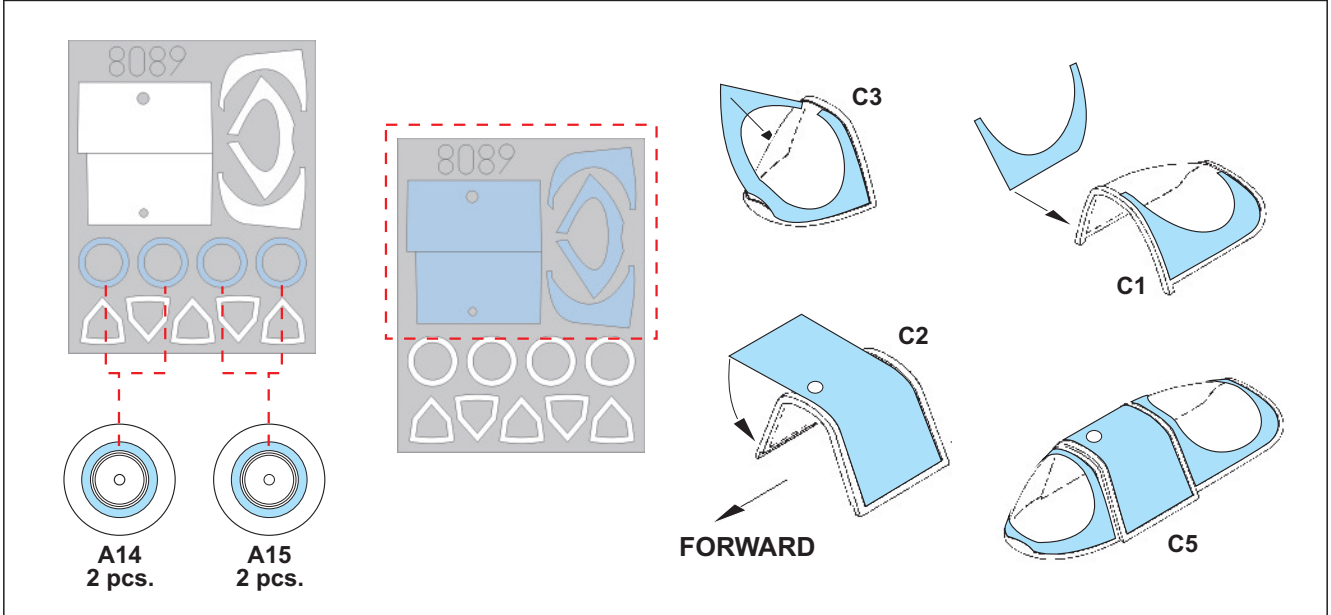
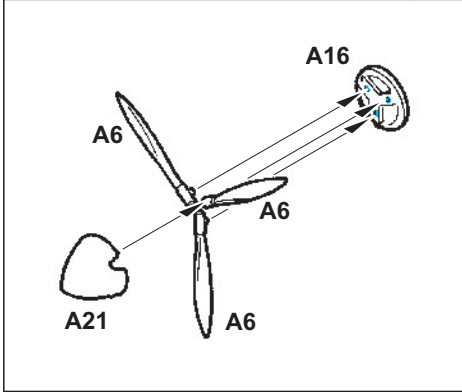
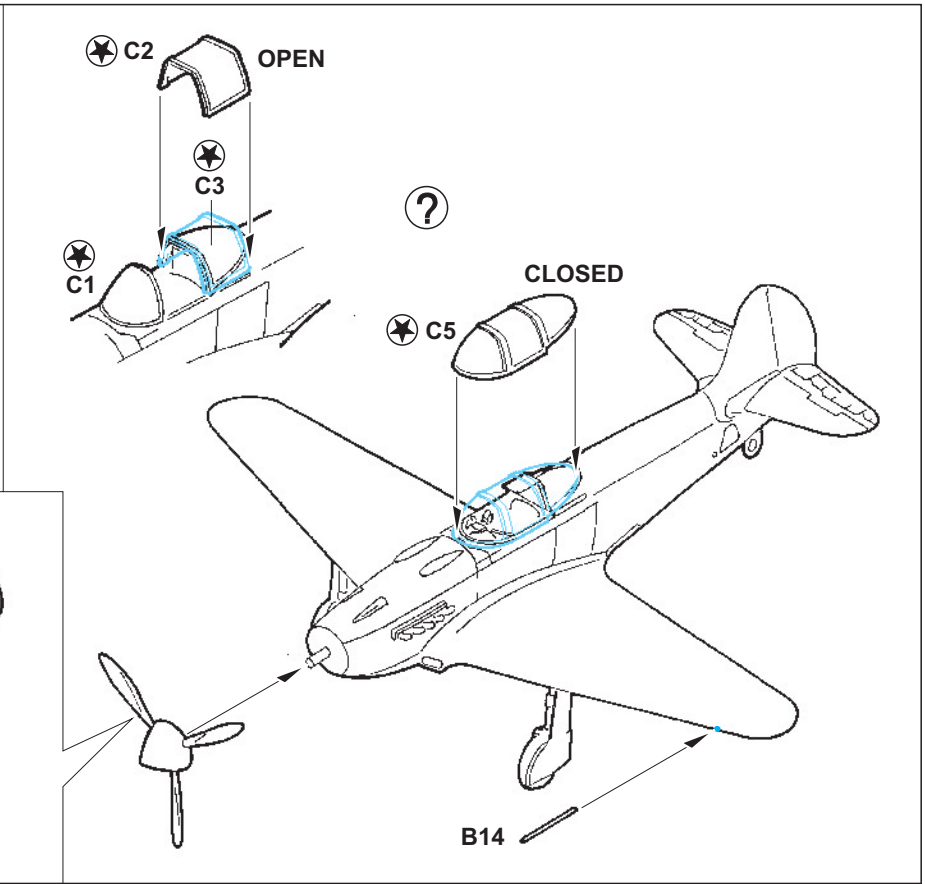
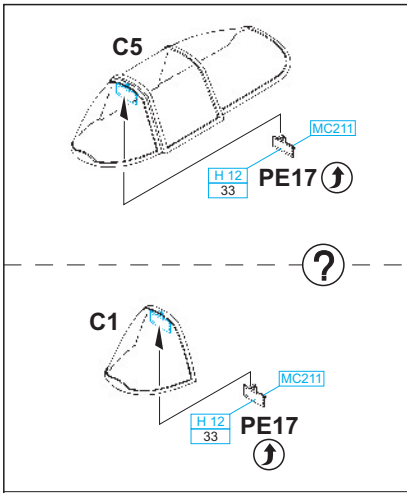

A Guards Lieutenant Colonel Boris Nikolaevich Yeryomin, 31st GIAP, Prague, Czechoslovakia, May, 1945

Major B. N. Yeryomin received from 'Saratov kolchoz farmer Ferapont Petrovich Golovaty' two Yaks with inscriptions. The first was a Yak-1, delivered in December 1942. He successfully fought in this aircraft along with some of his colleagues from his unit up to May, 1944, when it was decided to allocate the aircraft to the city of Saratov for display. As a replacement, B. N. Yeryomin received the second machine, a Yak-3, directly from Saratov on May 29, 1944. He fought in this aircraft progressively from the Ukraine all the way to Germany. Over the span of 342 combat flights, he gained six aerial victories. In August, 1945, this aircraft was picked out for participation in a display of aerial strength in Moscow. This plane was preserved, and remained on display in Moscow until the nineties. The appearance of this Yak changed with time. The dedication inscriptions 'От Феропонта Петровича Головатого 2-й САМОЛЕТ НА ОКОНЧАТЕЛЬНЫЙ РАЙЗРОН ВРАГА!' (From Ferapont Petrovich Golovaty, 2nd machine for the final destruction of the enemy) changed over the course of service, and by the end of the war, they were different on both sides of the fuselage from those when initially delivered, and small victory stars were added to denote kills by B. N. Yeryomin. In all, he got 23 kills over some seventy combat flights, fourteen of which were gained on the two dedicated birds. Among other awards, he received the Gold Star of the hero of the Soviet Union.

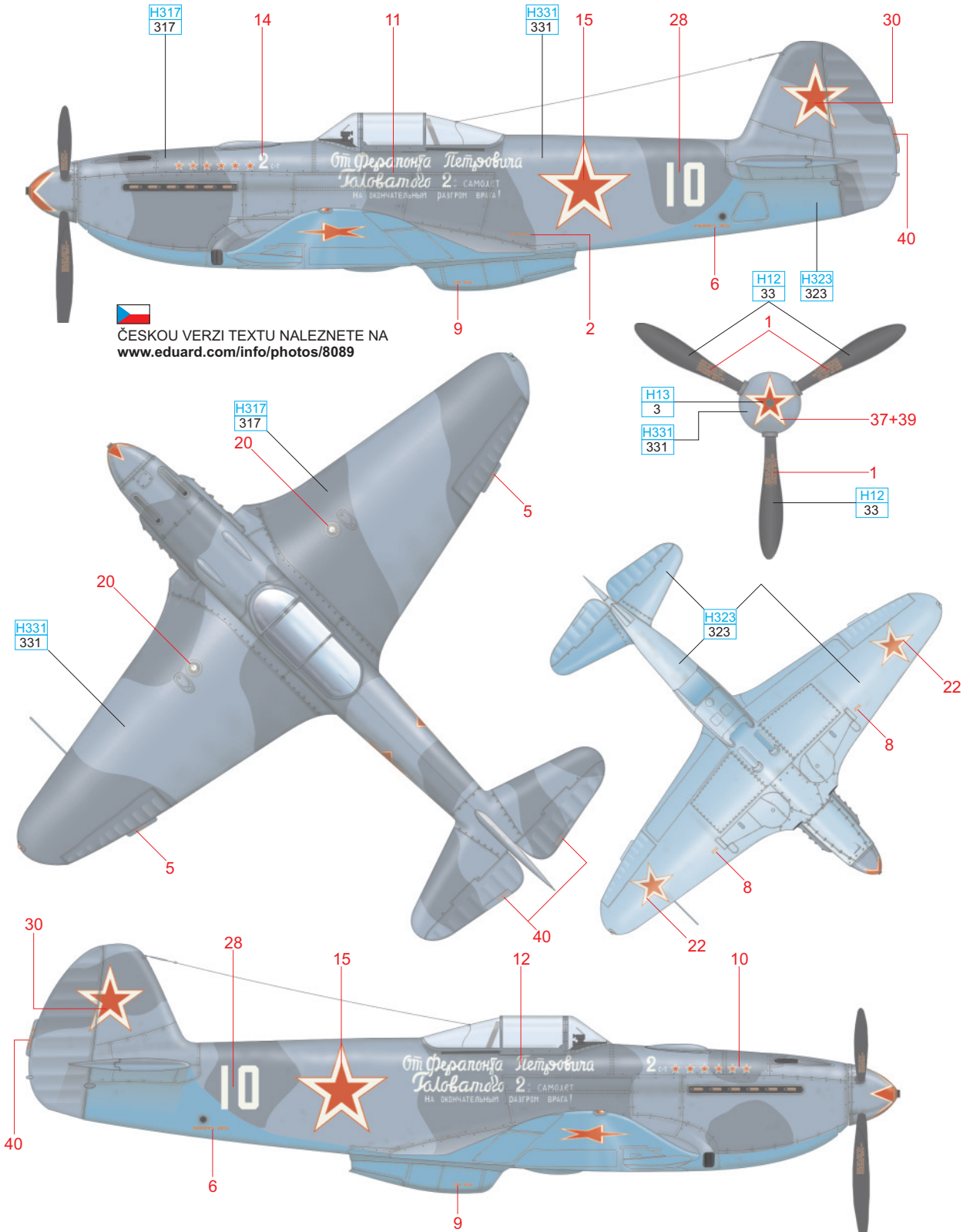

ČESKOU VERZI TEXTU NALEZNETE NA www.eduard.com/info/photos/8089

AMT-7	H323 323	AMT-11	H331 331	AMT-12	H317 317	RED	H13 3	BLACK	H12 33
-------	-------------	--------	-------------	--------	-------------	-----	----------	-------	-----------

B Lieutenant Semyon Ivanovich Rogovoi, 64th GIAP, 2nd Baltic Front, Fall, 1944

Although this is a relatively well known and often illustrated aircraft, details of it and its pilot, Lt. S. I. Rogovoi, are more obscure. According to memoirs, this Yak-3 was dedicated to him for his role in the saving of a vessel in the Amursk flotilla. Semyon I. Rogovoi served with the 64th GIAP / 4th GIAD from October 1944 to May, 1945 as a flight leader, and by the end of the war, he gained a minimum of five confirmed kills. The aircraft carried, with minor variation, a striking marking with a dedication inscription on both sides of the fuselage, reading 'Semyonu Rogovomu at amurskich krasnoflotsev' ('to Semyon Rogovoi from members of the Amursk Red Flotilla') The red spinner and rudder stripe were unit markings typical of the time for the 64th GIAP. The color stripes are often described as yellow, but it is possible that they were in white. The aircraft was built at Factory No. 292 in Saratov.



ČESKOU VERZI TEXTU NALEZNETE NA
www.eduard.com/info/photos/8089

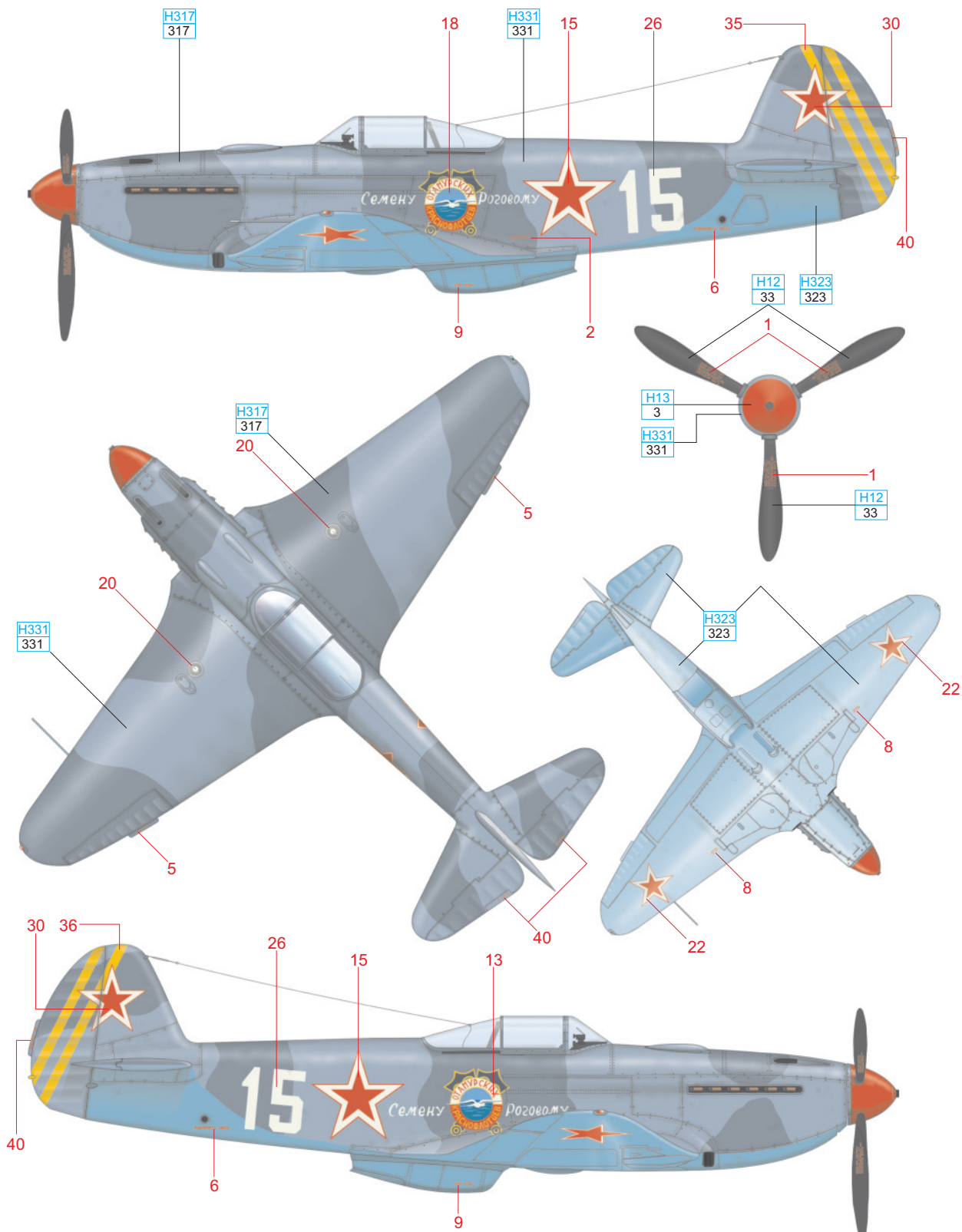

AMT-7	H323 323	AMT-11	H331 331	AMT-12	H317 317	RED	H13 3	BLACK	H12 33
-------	-------------	--------	-------------	--------	-------------	-----	----------	-------	-----------

eduard

C Lieutenant Colonel Anton Dmitrievich Yakimenko, 151st GIAP, Czechoslovakia, May, 1945

This illustration of A. D. Yakimenko's Yak-3 is based on a photograph of the starboard side of the aircraft. The photograph was taken on a Czechoslovak airfield at the end of the war. The nose of the aircraft was red with an exclamation mark, the purpose of which is not clear, and a marking of a flag with the inscription 'Na rodinu s pabedoj' (For the Fatherland with victory).

Yakimenko was made Hero of the Soviet Union for his successes in combat against the Japanese over Khalkhin-Gol. The beginning of the Great Patriotic War saw him as a Major on the border of Romania. His previous experiences in combat allowed him to quickly gain a kill over an He-111. His successes continued throughout the GPW and over the course of 1,055 combat missions, he took part in 92 air combats, and shot down 30 enemy aircraft (other sources claim 38 and 15). Some of his successes came while serving with a special fighter group 'Metch' (Sword), operating over Kursk. He remained with the Soviet Air Force, and was progressively promoted to higher rank. He sat in a cockpit for the last time at the end of 1972.



ČESKOU VERZI TEXTU NALEZNETE NA www.eduard.com/info/photos/8089

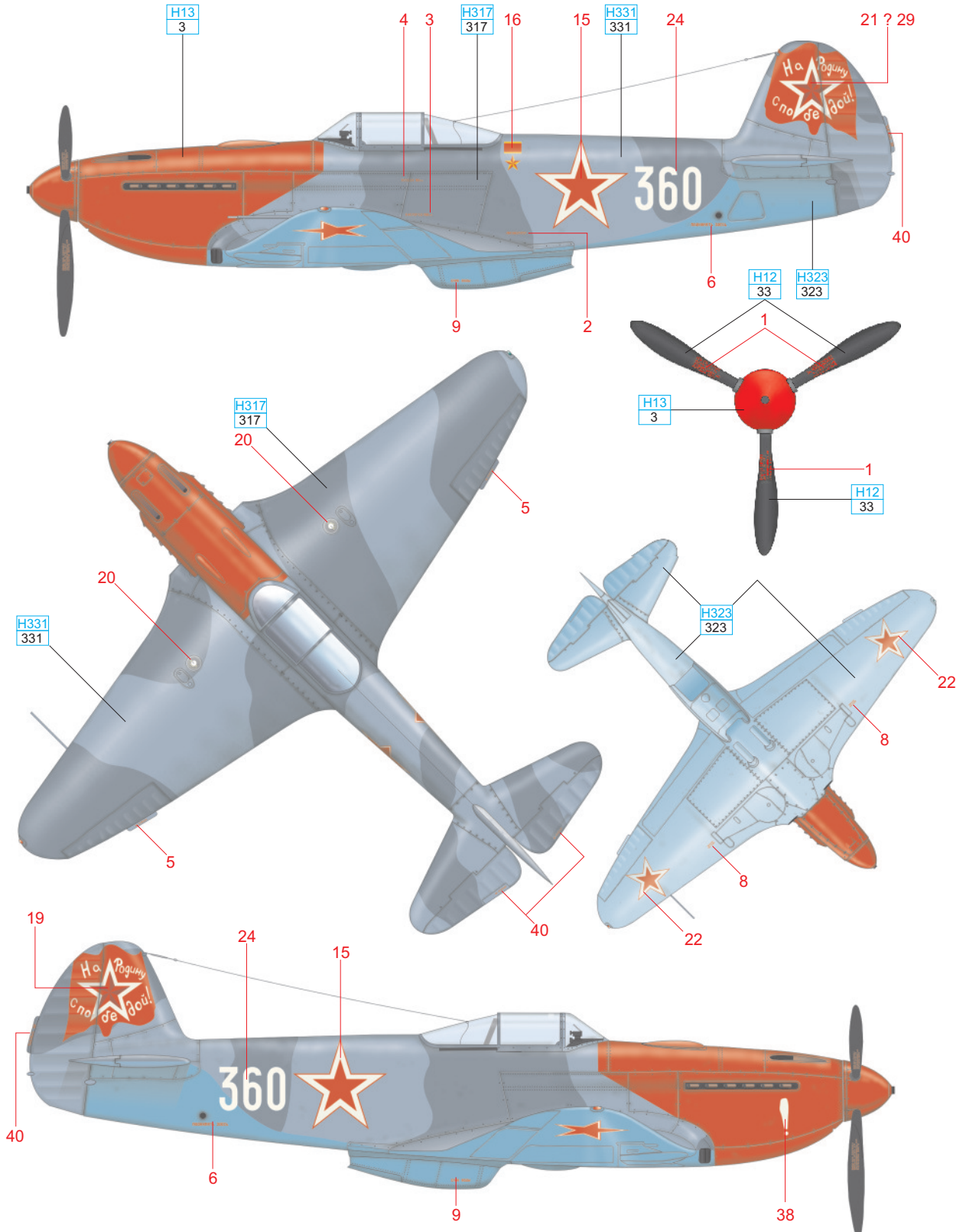

AMT-7	H323 323	AMT-11	H331 331	AMT-12	H317 317	RED	H13 3	BLACK	H12 33
-------	-------------	--------	-------------	--------	-------------	-----	----------	-------	-----------

D Generalmajor Georgii Nefyodovich Zakharov, 303rd IAD, East Prussia, Fall, 1944

Generalmajor G. N. Zakharov flew this Yak-3 over East Prussia in the fall of 1944. The aircraft carried a lightning flash on the fuselage, identifying it as an aircraft of the 303rd Fighter Division, and the emblem on the fuselage was painted by members of the Normandie-Niemen, which was in this division, and is a reference to their favorite CO as 'St. George' (Georgii). The spinner was painted in an atypical manner. The left profile is based on a period photograph, and the left one, along with the exact colors, are not certain.

G. N. Zakharov took part in combat during the Spanish Civil War in the services of the Spanish Republican air force, and in combat against the Japanese in China. Over the course of the Second World War, he flew 153 combat missions, seeing combat 48 times, and downing a total of 22 enemy aircraft. In April, 1945, he was awarded the Hero of the Soviet Union. He continued serving in different high ranking staff positions, after the war.



ČESKOU VERZI TEXTU NALEZNETE NA www.eduard.com/info/photos/8089

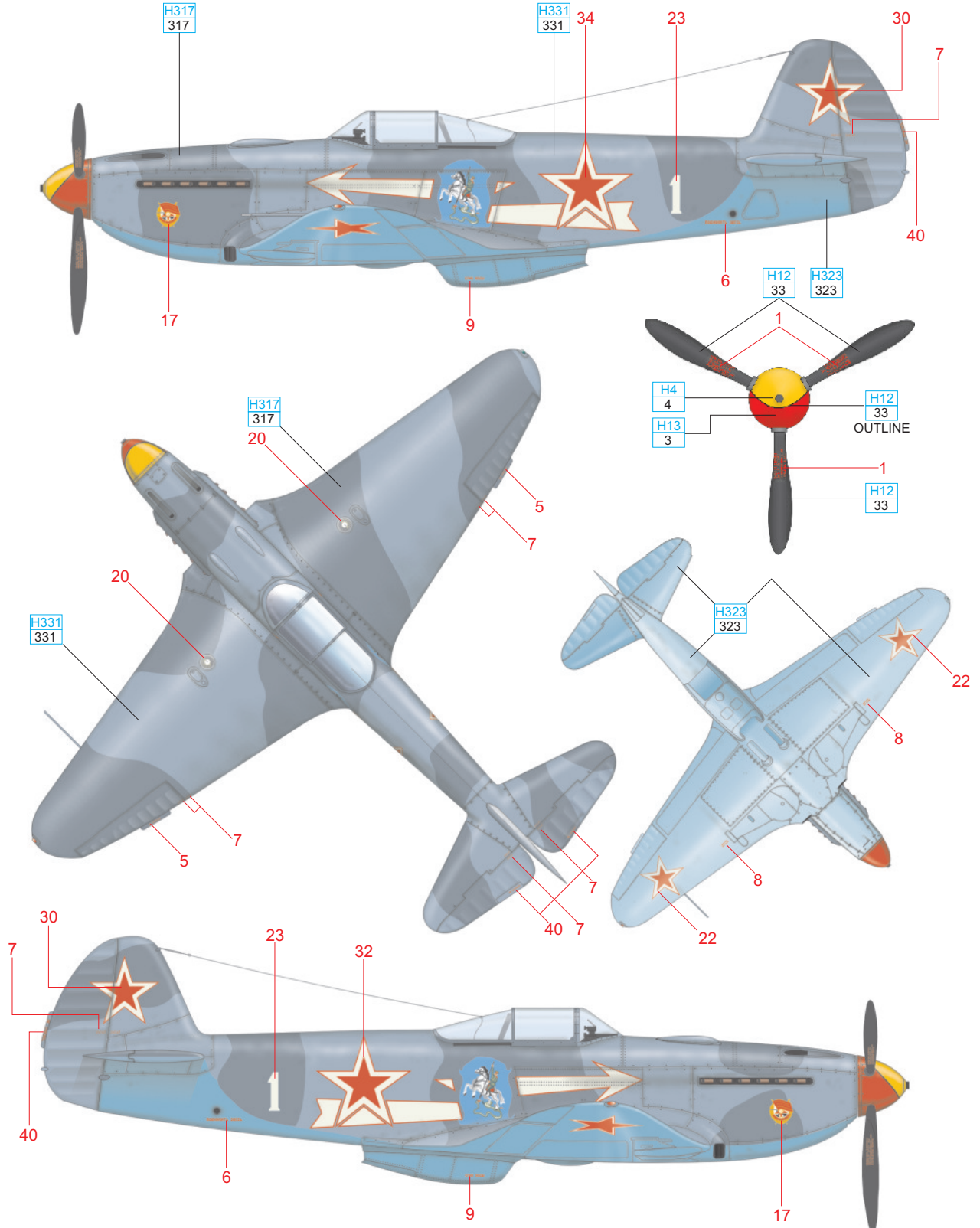

AMT-7	H323/323	AMT-11	H331/331	AMT-12	H317/317	YELLOW	H4/4	RED	H13/3	BLACK	H12/33
-------	----------	--------	----------	--------	----------	--------	------	-----	-------	-------	--------

E Lieutenant Colonel Ivan Vasilievich Maslov, 157th IAP, Germany, 1945

This aircraft, with the dedication of the 'Red October' collective Farm (in the Soviet Union, these were known by the abbreviated 'kolhoz') 'Kolkhoz Krasnyi Oktyabr', was assigned to Lt. Col. Ivan V. Maslov. This pilot spent his entire service career with the 157th IAP, starting as a member pilot in 1940, and ending up as unit CO. In February, 1944, he was the unit's exec, and he had by this time fifteen kills along with 15 shared, for which he was awarded the Hero of the Soviet Union. In a total of 350 combat flights in the I-16, LaGG-3, Hurricane, Yak-7 and Yak-3, he saw combat around a hundred times, and gained 23 kills with another 18 shared. He stayed with the 157th IAP until its disbandment in 1949.



ČESKOU VERZI TEXTU NALEZNETE NA
www.eduard.com/info/photos/8089

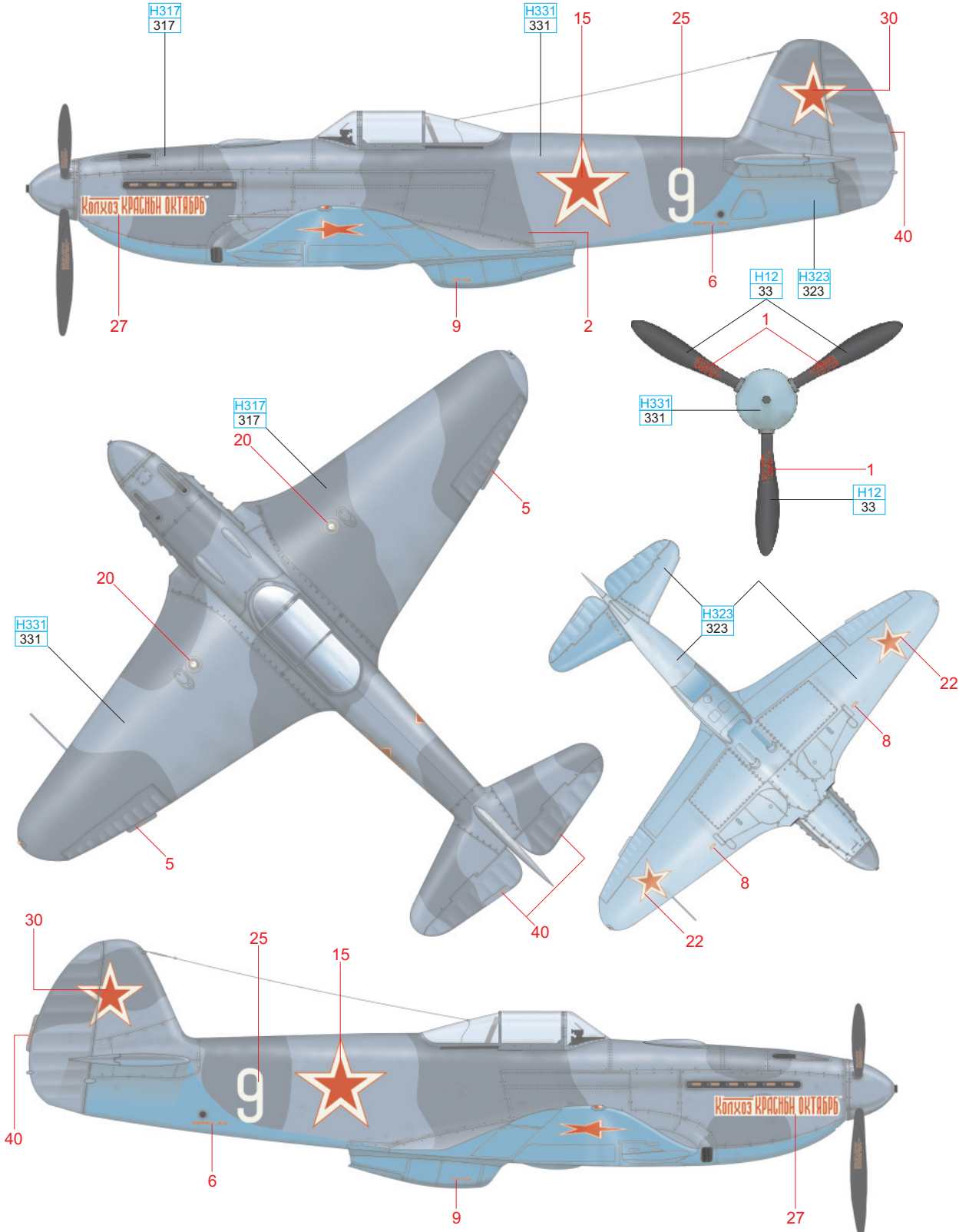

AMT-7	H323 323	AMT-11	H331 331	AMT-12	H317 317	BLACK	H12 33
-------	-------------	--------	-------------	--------	-------------	-------	-----------

eduard



8146
I-16 Type 17

8175
Fw 190A-8/R2



8202
Bf 110D

8221
F6F-3 Hellcat



1152
P-39 Airacobra
over New Guinea
DUAL COMBO