

Bf 109F-4

eduard

1/48 Scale Plastic Model Kit

ProfiPACK
edition



item No. 82114

No other aircraft is so intimately connected with rise and fall of the German Luftwaffe in the course of the WWII like the Messerschmitt Bf 109. As a very progressive design at the time of its invention, it had plenty of room for further development.

The evolution of this type outlived the era in which it was designed. The Bf 109s bore the brunt of Luftwaffe duties from the opening battles of Nazi Germany through to its final downfall.

As progressive as possible

The history of the Bf 109 begins with the requirement L.A. 1432/33 issued by Reich Ministry of Aviation (RLM) in late March 1933. It called for the development of a single-engined monoplane fighter. Proposals were submitted by Arado, Heinkel, Focke-Wulf and Bayerische Flugzeugwerke. The design bureau of the last-mentioned company was led by its technical director Willy Messerschmitt, who was riding a wave of popularity based on the success of his liaison aircraft, the Bf 108. Messerschmitt's goal was to create an aircraft with the best possible performance for the specified weight and size. Over the subsequent months, several prototypes were built that served first and foremost in development flights and further modifications. The aircraft was relatively small, and compared to the prevailing trends of the time, sported several quite revolutionary features such as low wing design, retractable landing gear, wing with a thin airfoil, wing slats, landing flaps, weapons firing through the propeller hub, and so on. Even the enclosed cockpit and the method of the airframe design were not very common just four years prior to the beginning of the Second World War. At its conception, the Bf 109 was a very promising asset despite some powerplant troubles. These were solved by the introduction of the DB 601. This engine, together with its extrapolated development DB 605, is umbilically connected to the success of the Bf 109. These two-row, twelve-cylinder inverted V engines powered several tenths of thousands of 109s in over 25 versions and variants.

From Spanish War to the Reich Defence

The first combat use of Bf 109 occurred during Spanish Civil War, where three developmental Bf 109s were deployed in December 1936. The main reason of revealing the modern fighter to the world was quite down-to-earth: To validate its abilities in aerial combat. Shortly thereafter, production aircraft in the form of the Bf 109B-1 began to reach 2.J/88, the Legion Condor. The desire of Germany to demonstrate its aerial prowess to potential foes was advanced further in international sport meets. The triumphs attained in Zurich in the summer of 1937 were complemented several months later by grabbing the speed record of 379.63 mph (610.95 km/h). In very short order, the progressive developments represented by the C, D and E versions appeared. Despite this, the delivery of the aircraft to combat units did not sustain a rate that was desired by military brass. Even by August 1938 the Bf 109 accounted for less than half of the

643 front line fighters in service. The later months saw an increase in these rates. By the time of the invasion of Poland (which saw the participation of only some 200 aircraft) the Luftwaffe possessed the best fighter produced in continental Europe. With both a qualitative and quantitative advantage, the fighter wing of the Luftwaffe entered the Polish campaign, Blitzkrieg against the West, and the Battle for France. With one foot in the door that was the English Channel, the Luftwaffe embarked on the attacks on Britain in the summer months of 1940. Here, the first weakness of the Bf 109 emerged: The inability to carry drop tanks that would have enabled the type to effectively escort bombers to England. This was one of the factors responsible for the defeat of the Luftwaffe in the Battle of Britain. Experiences gained in 1940 led to the development of the F version prior to the spring of 1941. The elegance of the Bf 109 crested with the "Friedrich". Following a largely defensive stance over the Channel and northern France, the Bf 109F took on a more offensive role in Operation Barbarossa in the east, and in northern Africa. In later duties with the "Jagdwaaffe" during the second phase of the war in the east, and in the "Defence of the Reich" from 1943 to 1945, the Bf 109s served in the form of the G version, followed by the K. Even if it was clear the development of the Bf 109 was depleted by the end of the war, the aircraft was still able to keep pace with the foes that it encountered. Besides its primary purpose as a fighter, the Bf 109 also appeared as a fighter-bomber, reconnaissance platform, night fighter, trainer and rammjäger.

The kit: Bf 109F-4

The Bf 109F series (Friedrich) was a major improvement of the Bf 109E. There were numerous aerodynamical changes, giving the Bf 109 the shape, which was close to the "definitive" appearance. The engine cowling was completely redesigned and was more rounded and streamlined. The spinner was larger, and its shape transitioned smoothly into the line of the front fuselage. The oil cooler radiator below the nose was also streamlined. The wing lost its typical rectangle shape, as a new, rounded wingtips were developed. The armament was also revised and consisted of two .312 in (7.92 mm) MG 17 machine guns mounted on top of the engine and one 20mm cannon firing through the propeller spindle. The new aircraft was well received as it was the best handling Bf 109 of them all. The F-4 sub-variation was using VDM 9-12010 propeller with broader blades and got the new cannon Mauser MG 151/20. The first Bf 109F-4s arrived in June 1941 and the production ran from the May 1941 to the same month a year later. During that period 1,841 of the Bf 109F-4 were produced.

ATTENTION



UPOZORNĚNÍ



ACHTUNG



ATTENTION



注意



Carefully read instruction sheet before assembling. When you use glue or paint, do not use near open flame and use in well ventilated room. Keep out of reach of small children. Children must not be allowed to suck any part, or pull vinyl bag over the head.



Před započítím stavby si pečlivě prostudujte stavební návod. Při používání barev a lepidel pracujte v dobře větrané místnosti. Lepidla ani barvy nepoužívejte v blízkosti otevřeného ohně. Model není určen malým dětem, mohlo by dojít k požití drobných dílů.

INSTRUCTION SIGNS * INSTR. SYMBOLS * INSTRUKTION SINNBILDEN * SYMBOLES * 記号の説明

OPTIONAL
VOLBABEND
OHNOUTSAND
BROUSITOPEN HOLE
VYVRTAT OTVORSYMETRICAL ASSEMBLY
SYMETRICKÁ MONTÁŽREMOVE
ODŘÍZNOUTREVERSE SIDE
OTOČITAPPLY EDUARD MASK
AND PAINT
POUŽIT EDUARD MASK
NABARVIT

PARTS



DÍLY



TEILE



PIÈCES



部品

PLASTIC PARTS

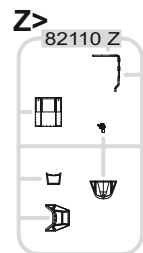
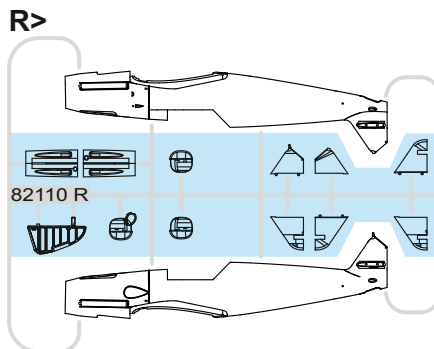
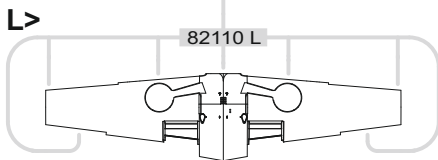
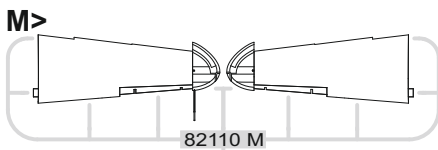
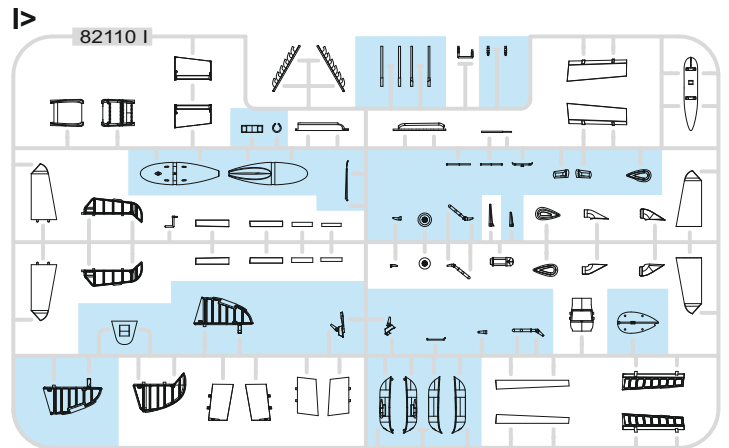
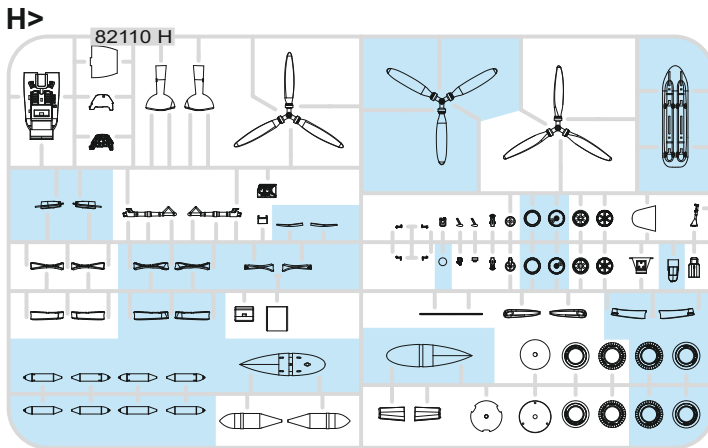
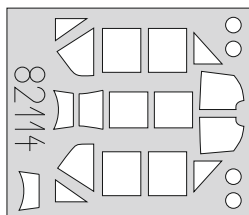
eduard
MASK

PE - PHOTO ETCHED DETAIL PARTS

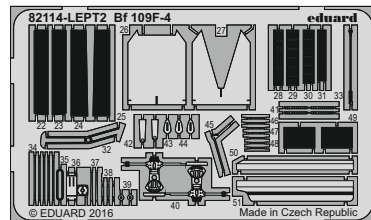
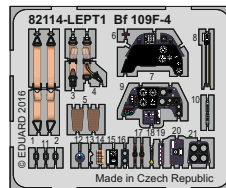

-Parts not for use. -Teile werden nicht verwendet. -Pièces à ne pas utiliser. -Tyto díly nepoužívejte při stavbě. - 使用しない部品

COLOURS



BARVY



FARBEN



PEINTURE



色

GSI Creos (GUNZE)		MISSION MODELS	
AQUEOUS	Mr.COLOR	PAINTS	
H2	C2	MMP-047	BLACK
H11	C62	MMP-001	FLAT WHITE
H12	C33	MMP-047	FLAT BLACK
H47	C41	MMP-012	RED BROWN
H51	C11	MMP-063	LIGHT GULL GRAY
H65	C18	MMP-088	RLM70 BLACK GREEN
H66	C119	MMP119	RLM79 SAND YELLOW
H68	C36	MMP-049	RLM74 DARK GRAY
H69	C37	MMP-050	RLM75 GRAY
H70	C60	MMP-056	RLM02 GRAY
H77	C137	MMP-040	TIRE BLACK
H80	C54		KHAKI GREEN
H90	C47		CLEAR RED

GSI Creos (GUNZE)		MISSION MODELS	
AQUEOUS	Mr.COLOR	PAINTS	
H94	C138		CLEAR GREEN
H413	C113	MMP-090	RLM04 YELLOW
H414	C114	MMP-003	RLM23 RED
H416	C116	MMP-089	RLM66 BLACK GRAY
H417	C117	MMP-051	RLM76 LIGHT BLUE
H418	C118	MMP-055	RLM78 LIGHT BLUE
Mr.METAL COLOR		METALLICS	
MC213		MMM-008	STEEL
MC214		MMM-001	DARK IRON
Mr.COLOR SUPER METALLIC		METALLICS	
SM201		MMC-001	SUPER FINE SILVER
Mr.COLOR GX		METALLICS	
GX05			SUSIE BLUE

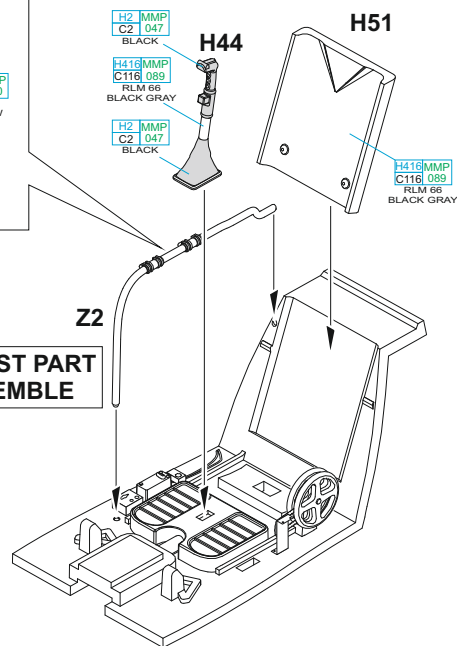
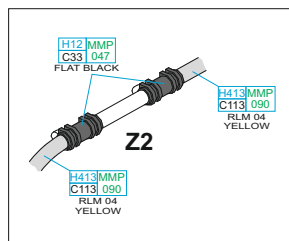
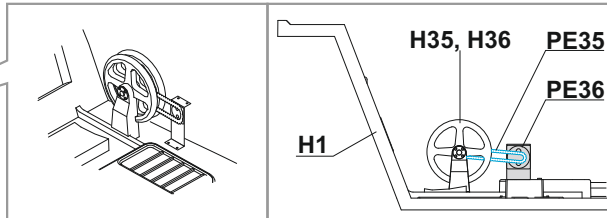
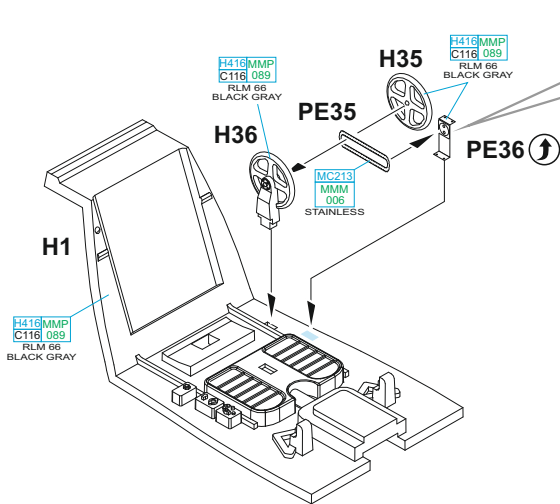

THE LATEST PART TO ASSEMBLE

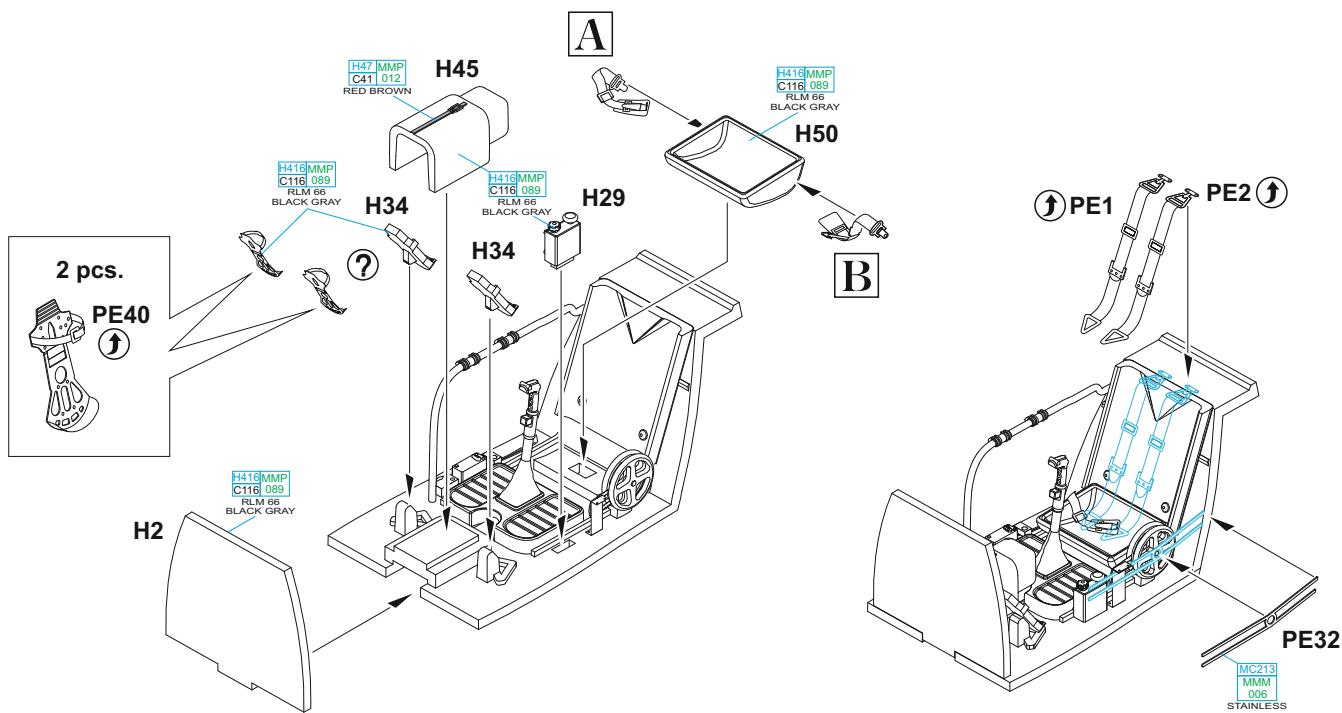
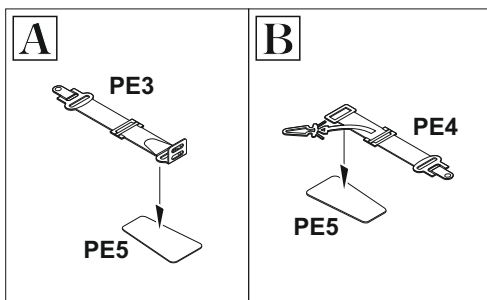

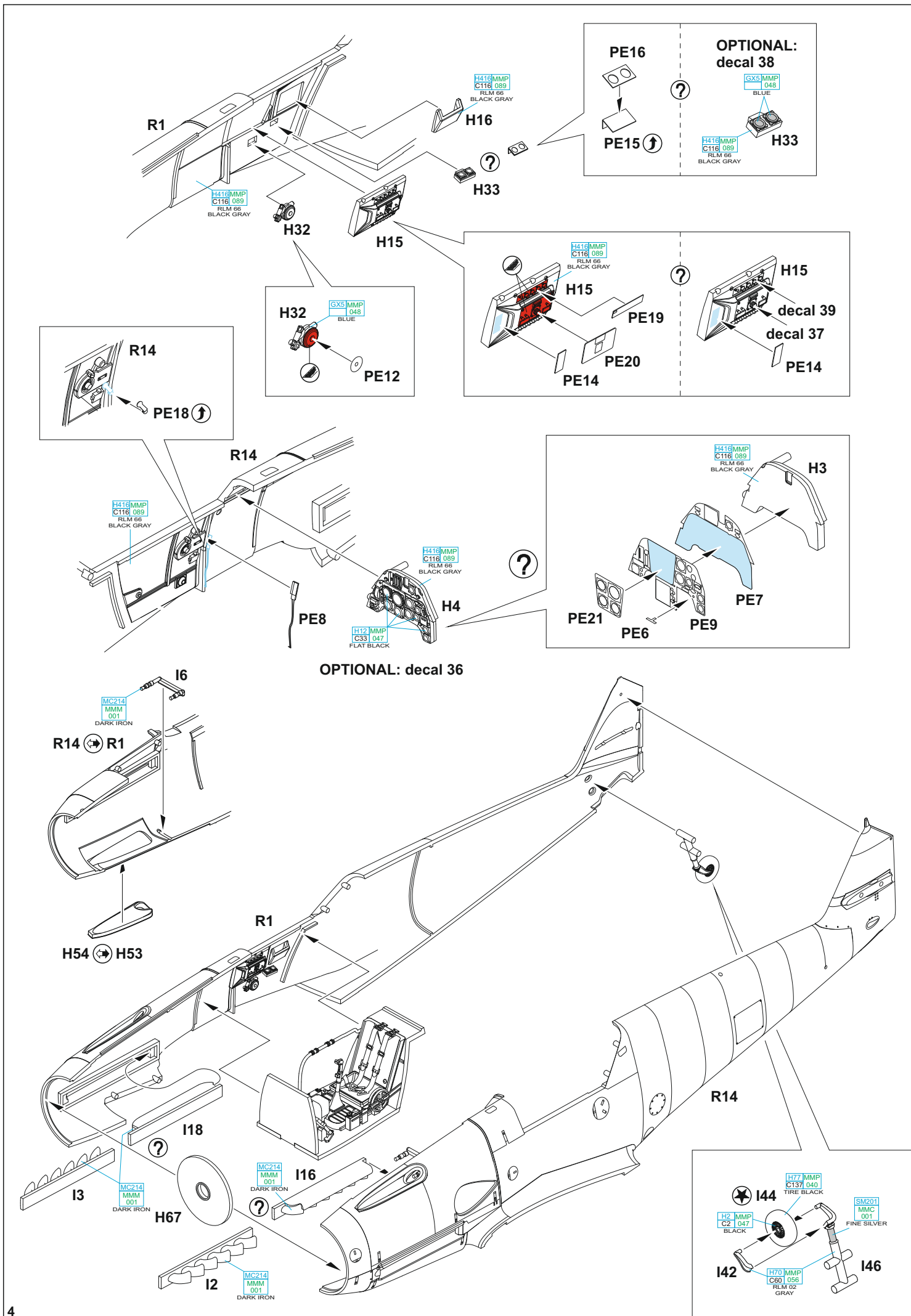

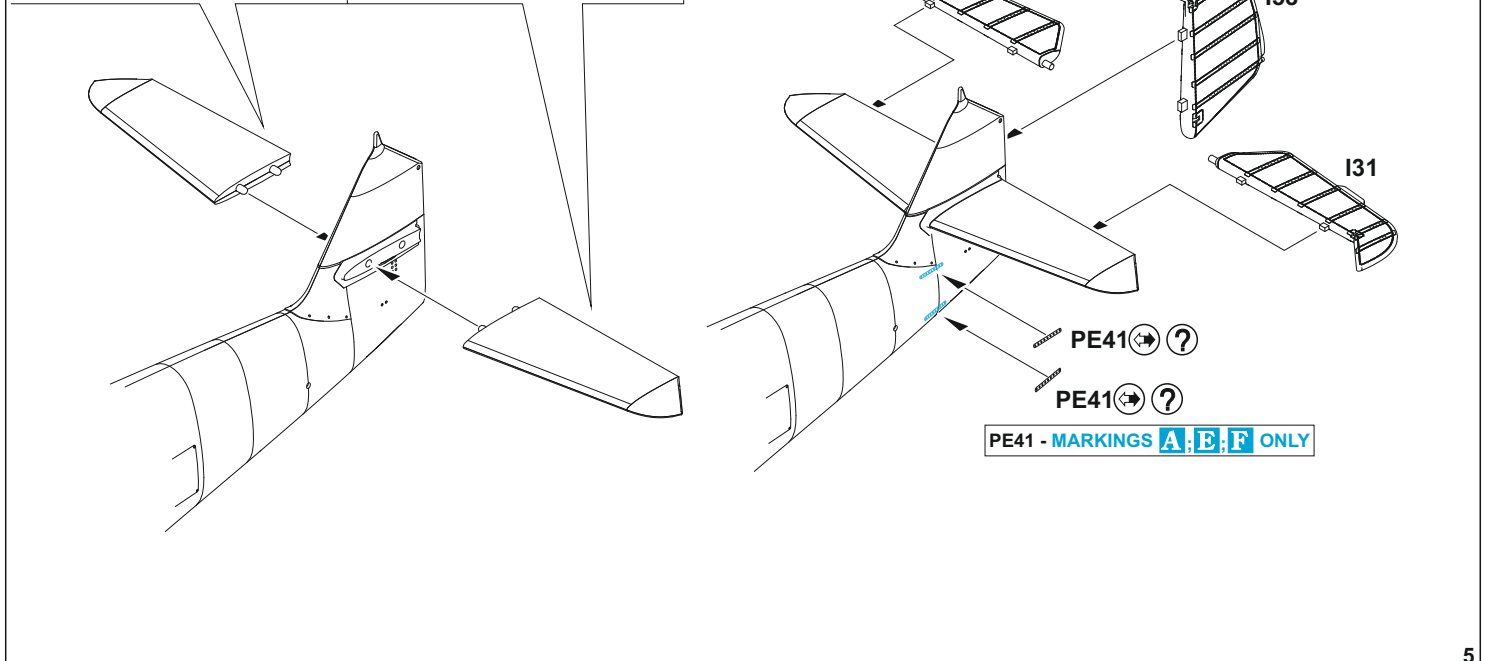
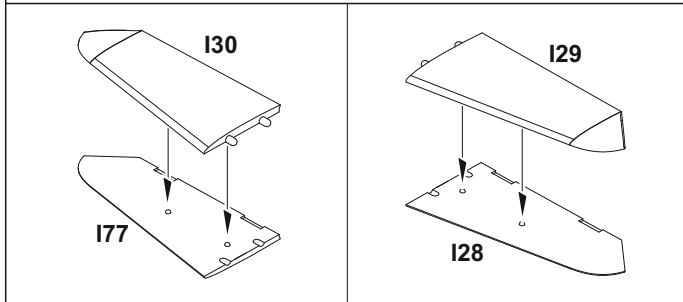
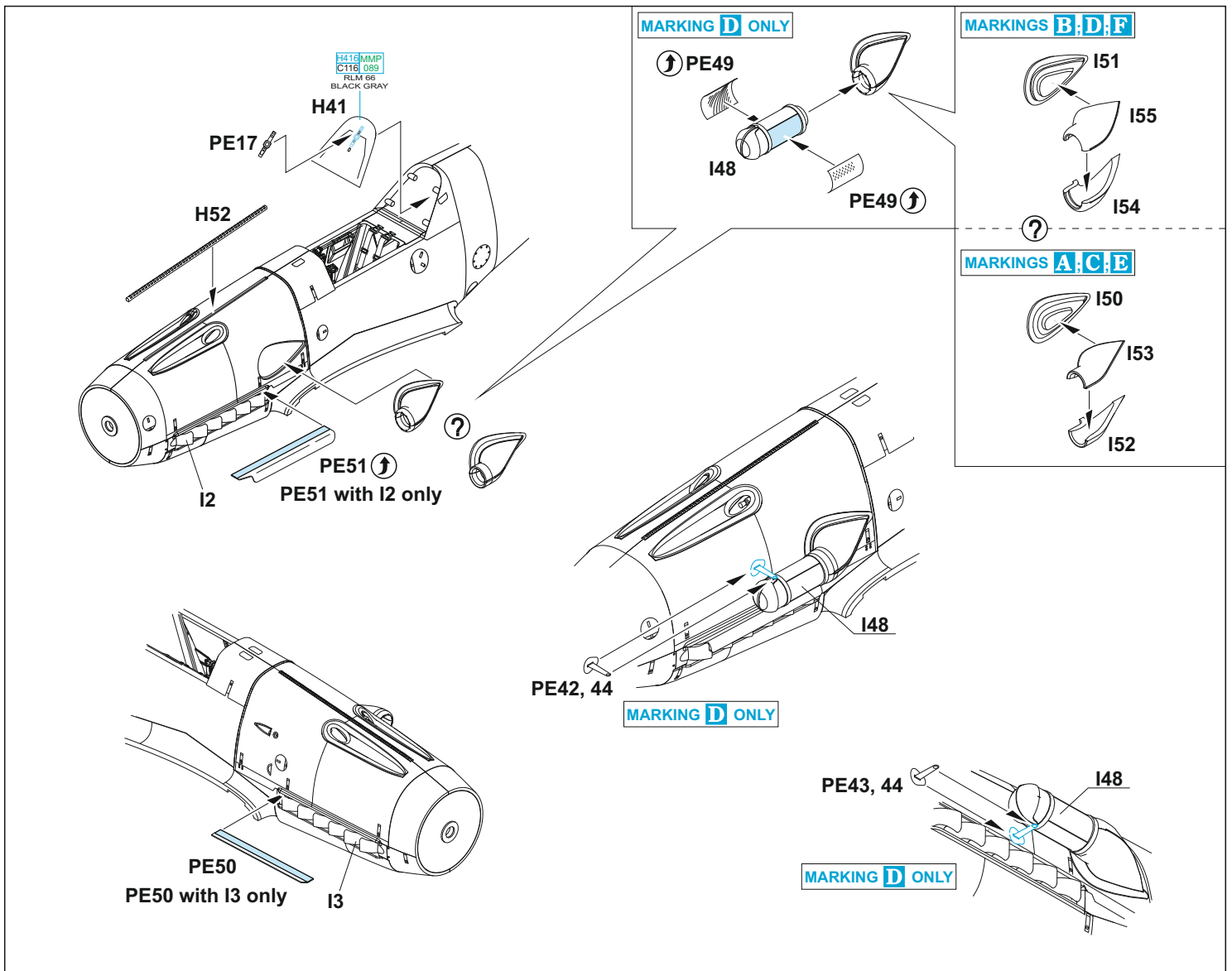

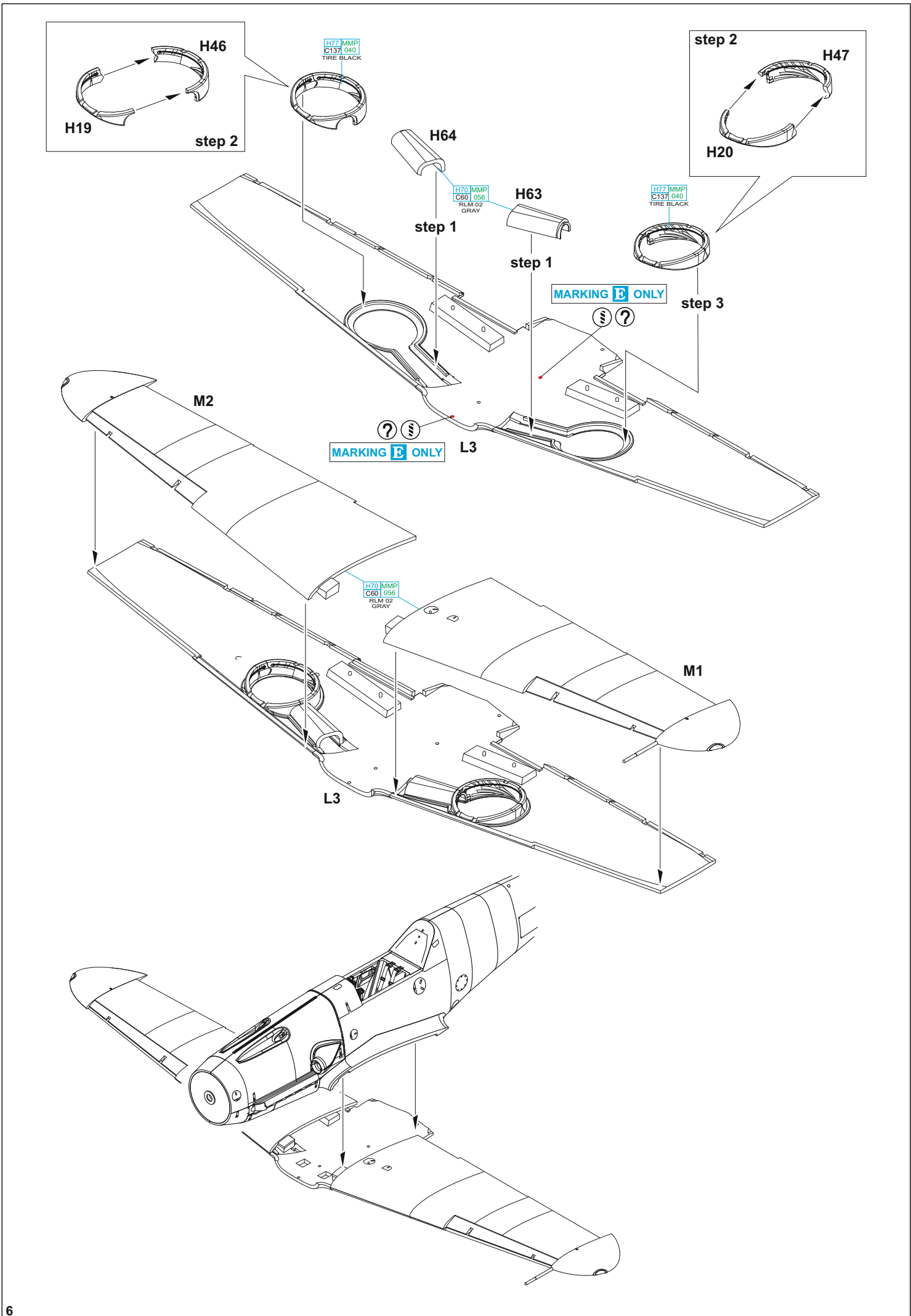

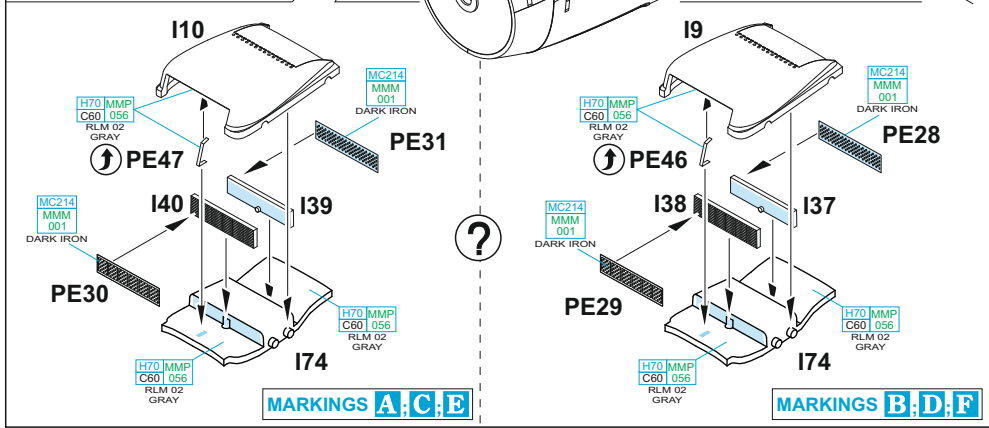
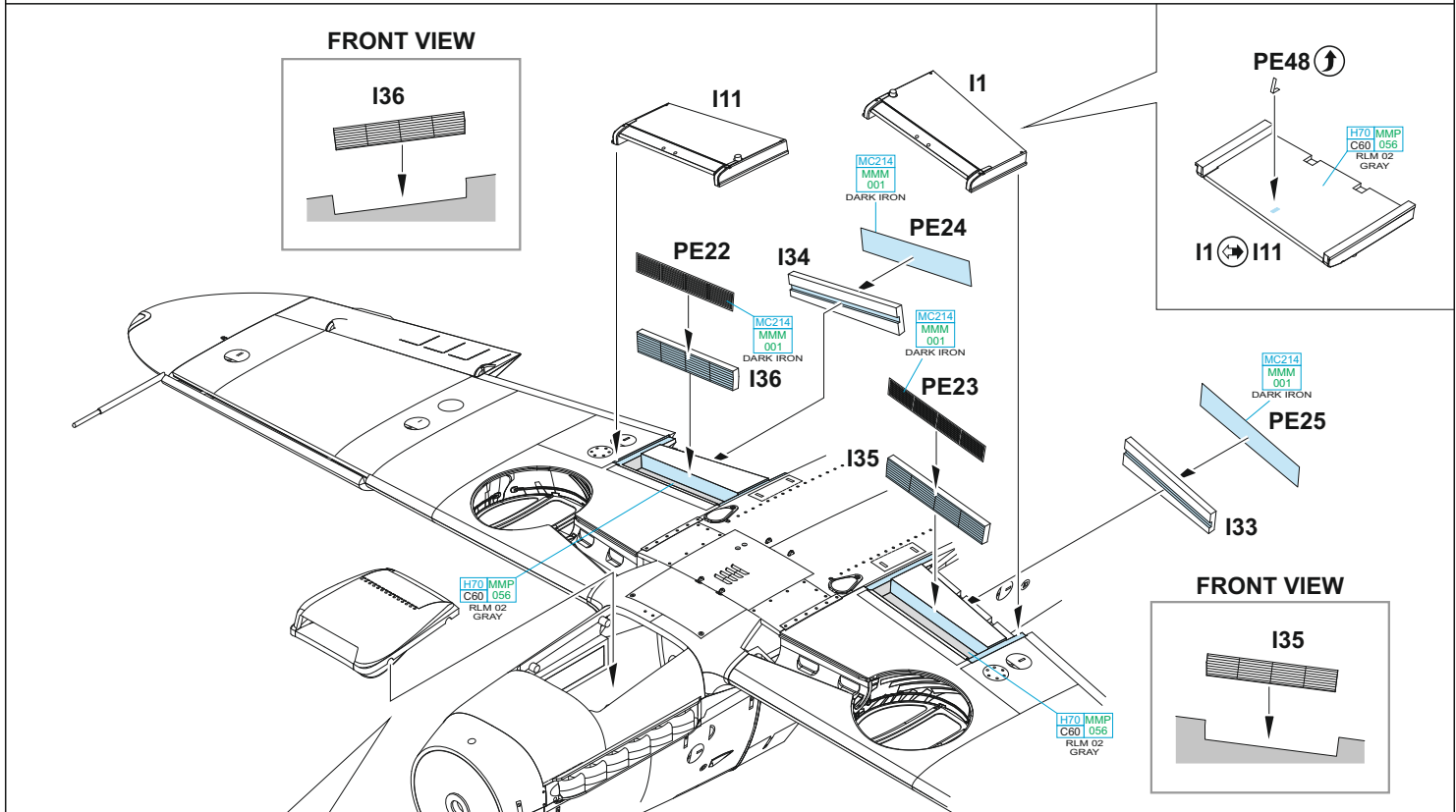
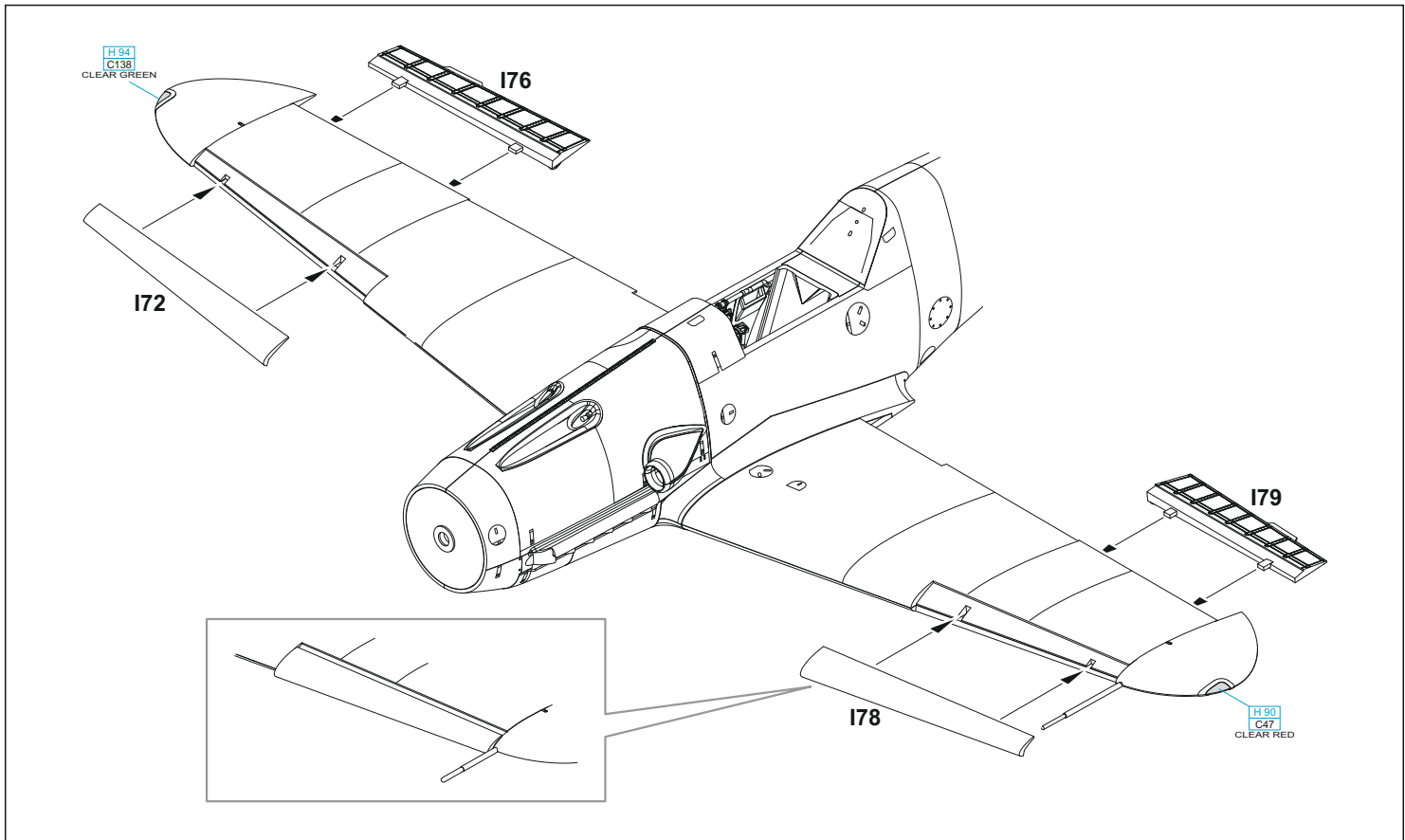

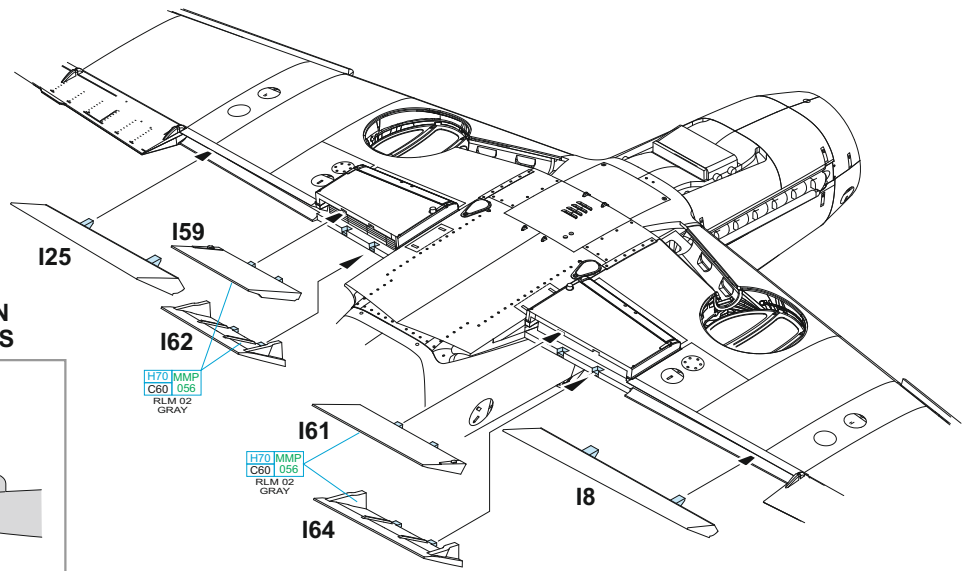

CORRECT POSITION OF RADIATOR FLAPS

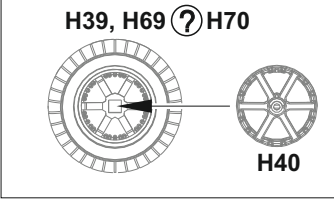
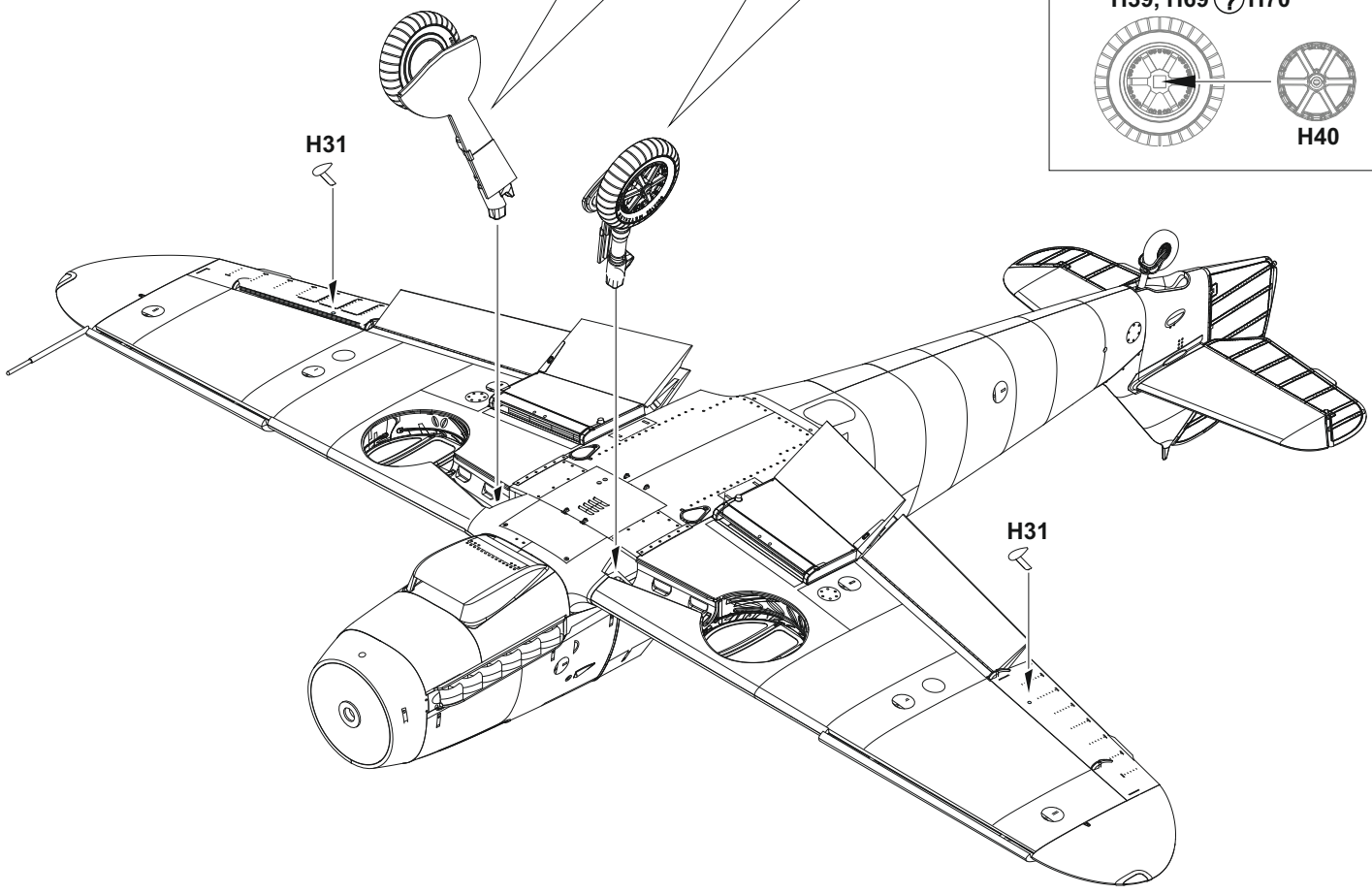
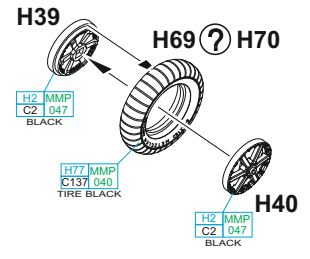
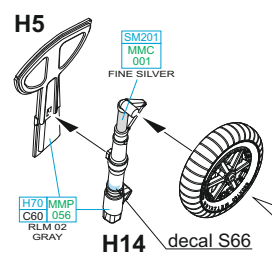
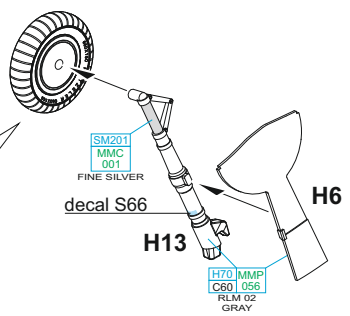
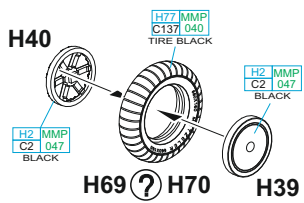
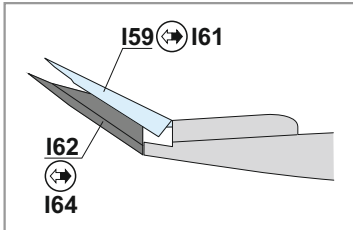

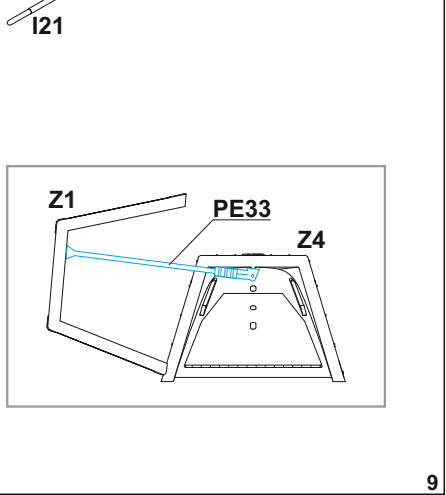
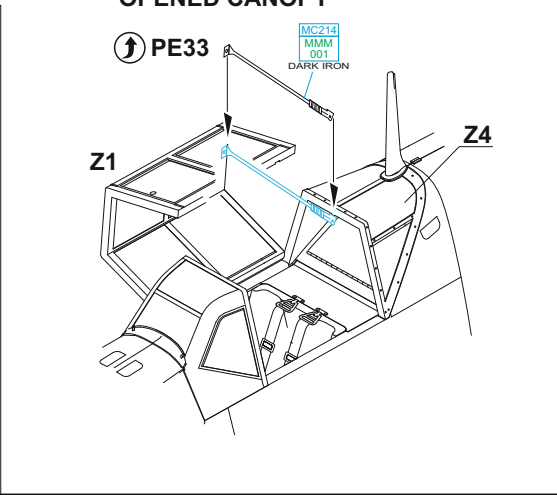
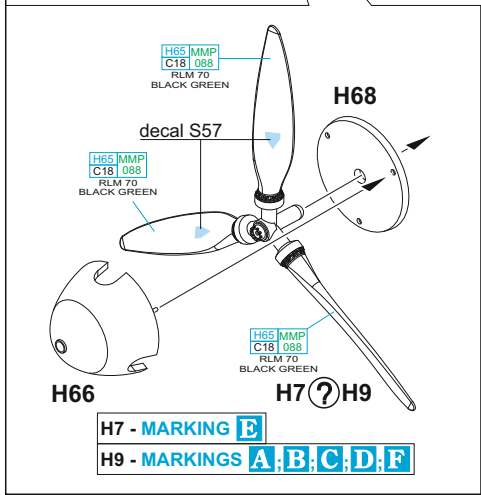
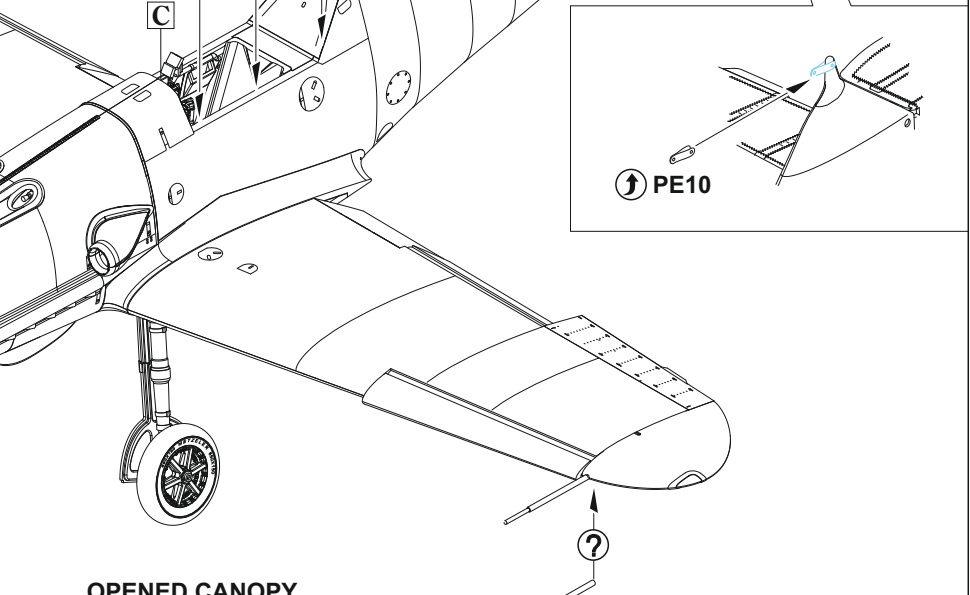
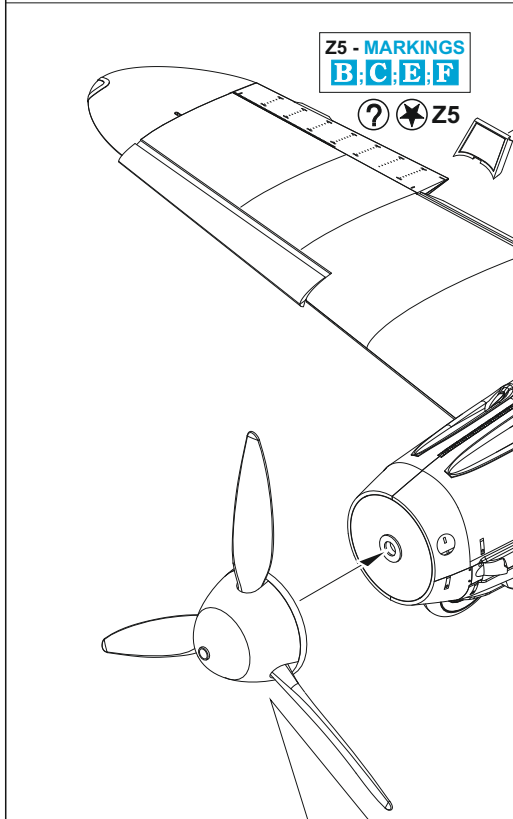
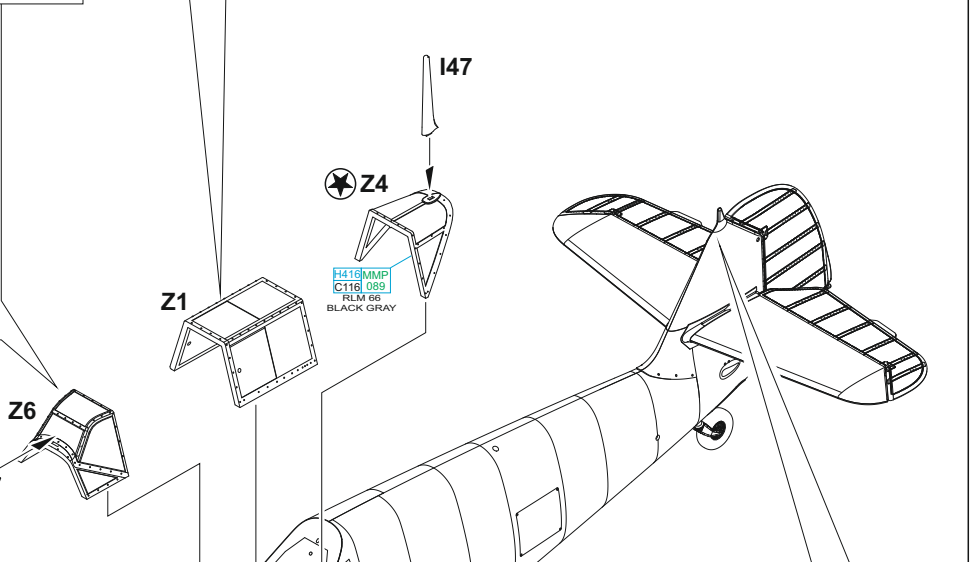
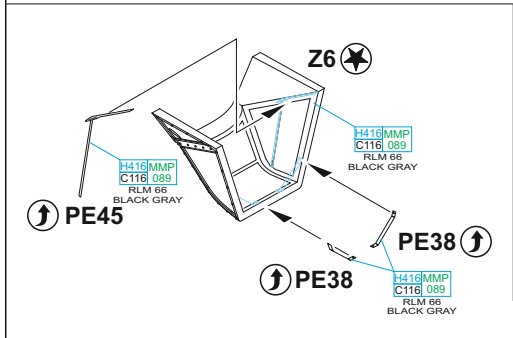
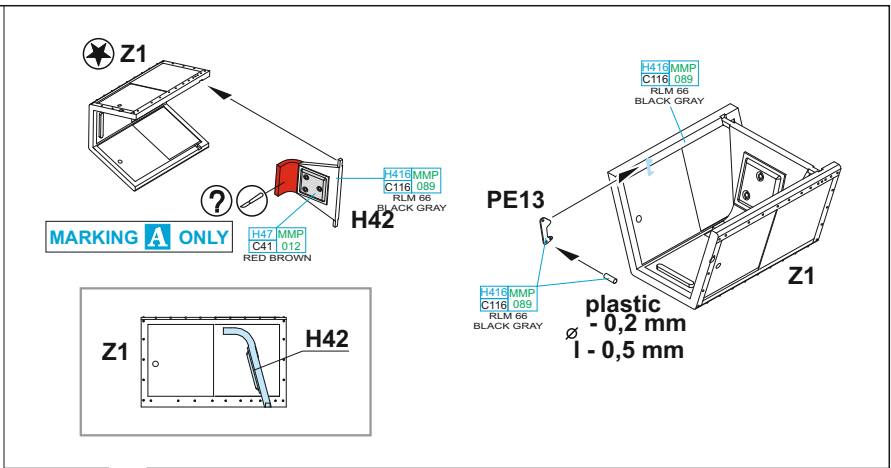
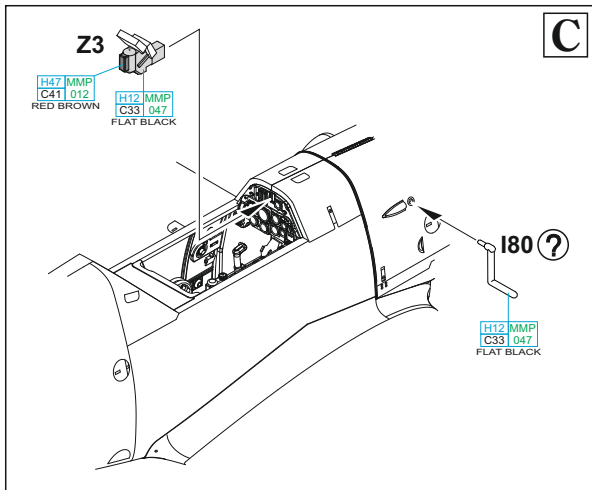

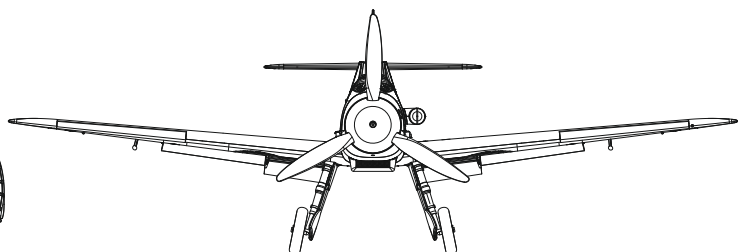
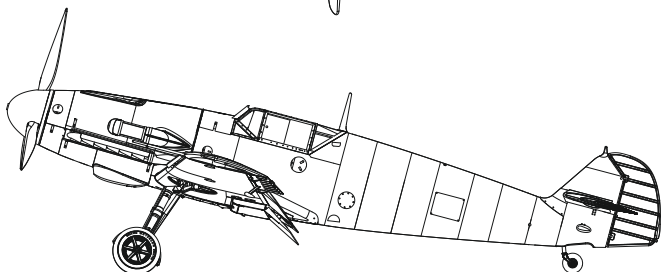
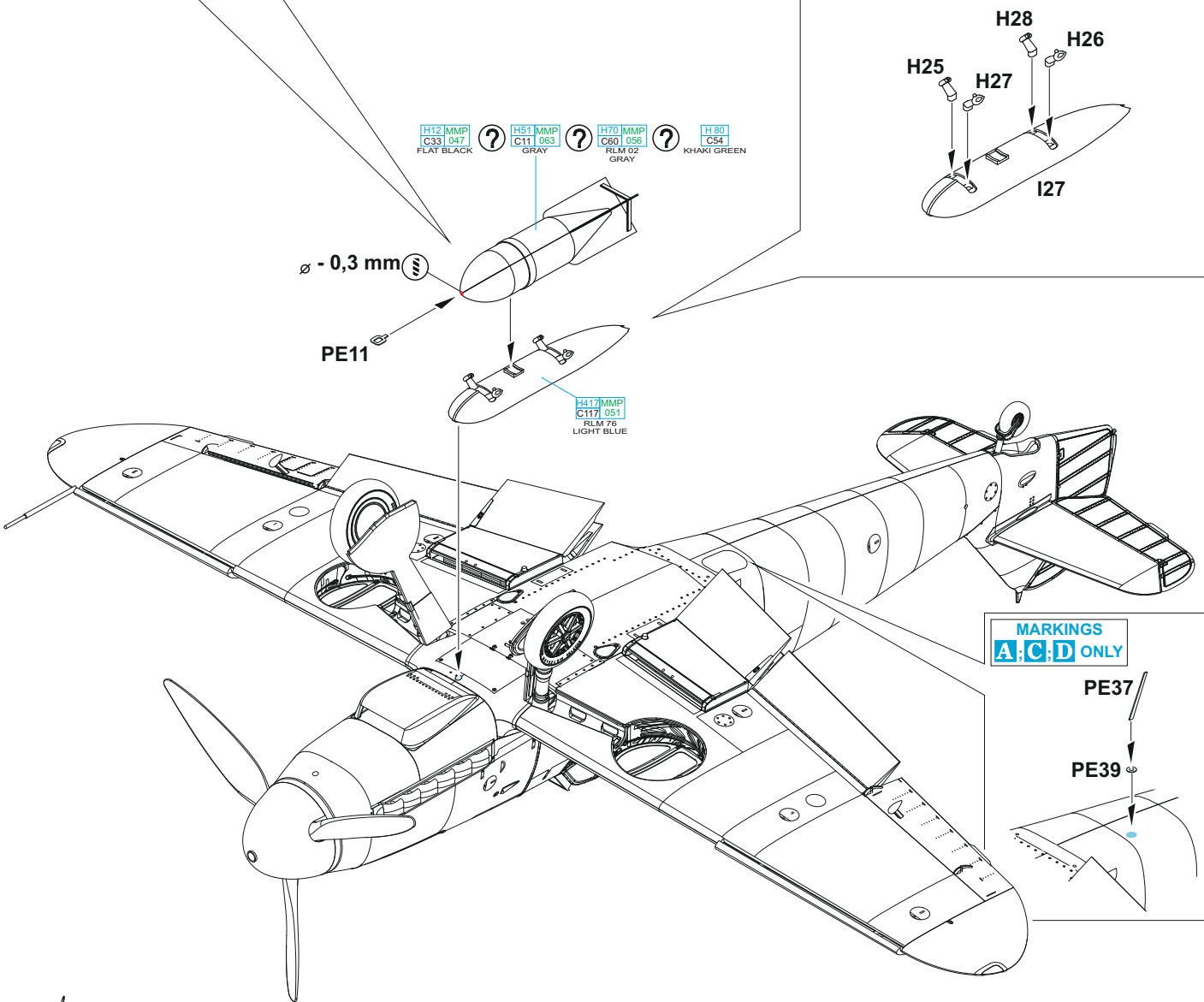
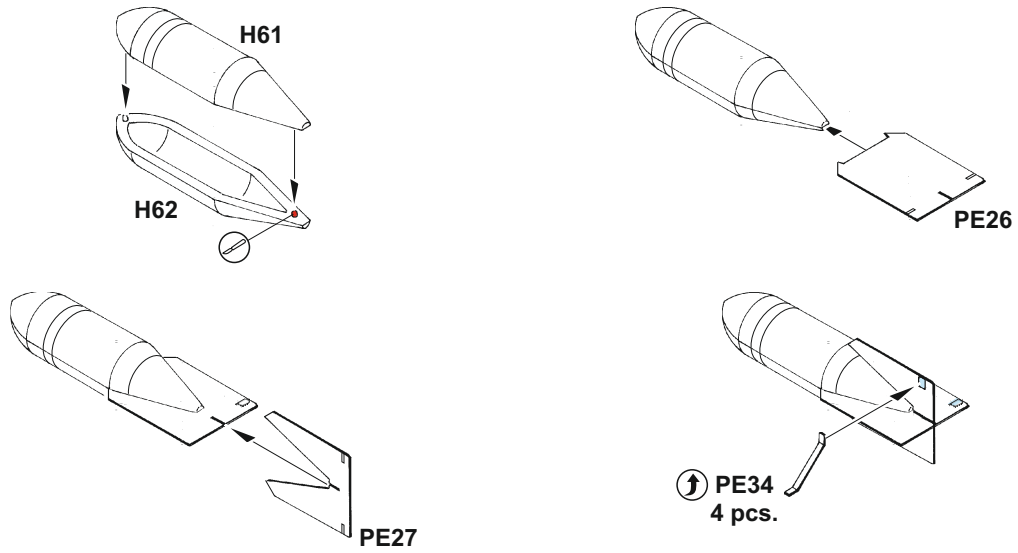

eduard
MASK

82114

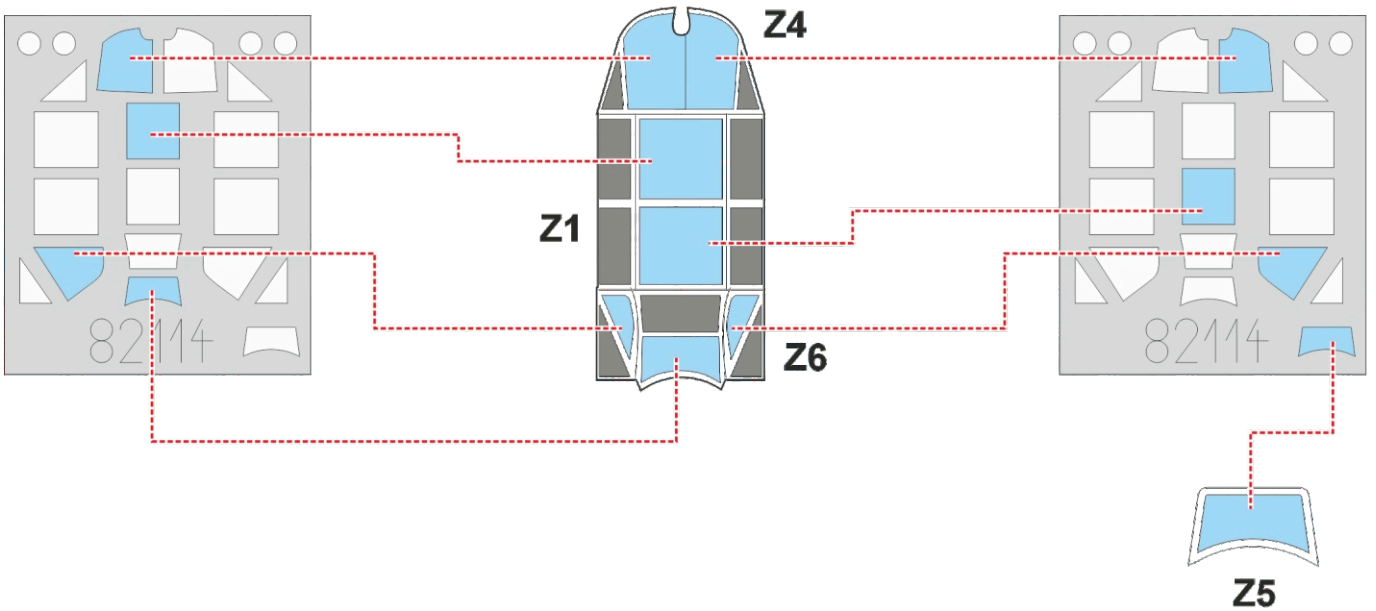
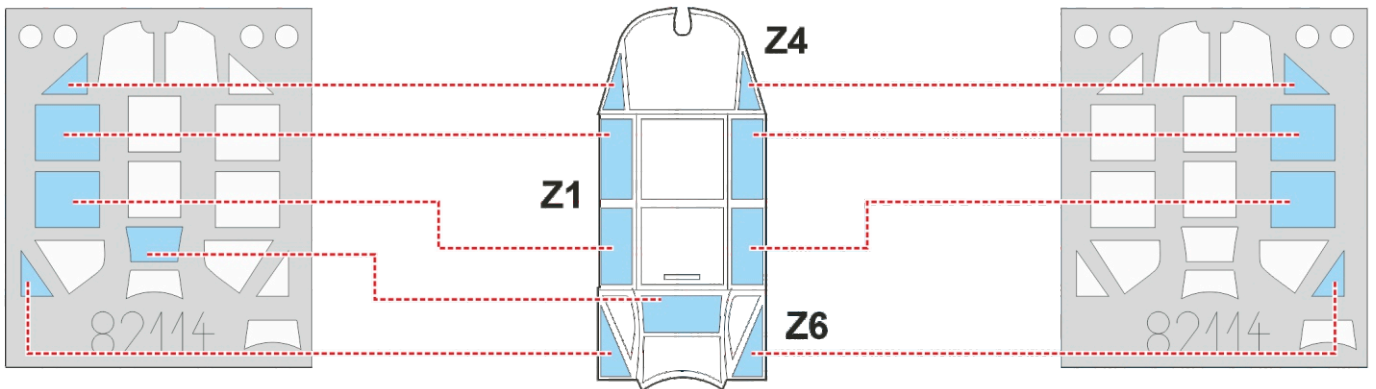
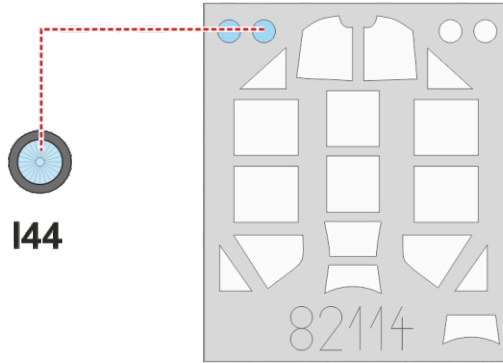

A Bf 109F-4, WNr. 7183, Hptm. Hans Hahn, III./JG 2, St. Pol, France, October 13, 1941

Hans „Assi“ Hahn, a fighter ace and recipient of the Knight's Cross with oak leaves was in command of 4./JG 2 from December, 1939 and starting from October 1940 he overtook the lead of III./JG 2. Fifty kill marks on the rudder related to his service on the Western Front. Hahn added the fiftieth kill to his tally on October 13, 1941, shooting down a Spitfire near Boulogne-sur-Mer. Altogether he destroyed 66 enemy aircraft in the West. In late 1942 "Assi" Hahn moved to the East and commanded II./JG 54 from November 1, 1942. On February 21, 1943, he was downed and captured. He spent seven years in captivity, returning back to Germany in 1950. He wrote a book about his life in prison Prisoner of War in Russia (Ich spreche die Wahrheit - I Speak the Truth). Hahn's total score stands at 108 kills. The rooster head was the crest of III./JG 2, based on Hahn's family name ("der Hahn" means "the rooster" in English).

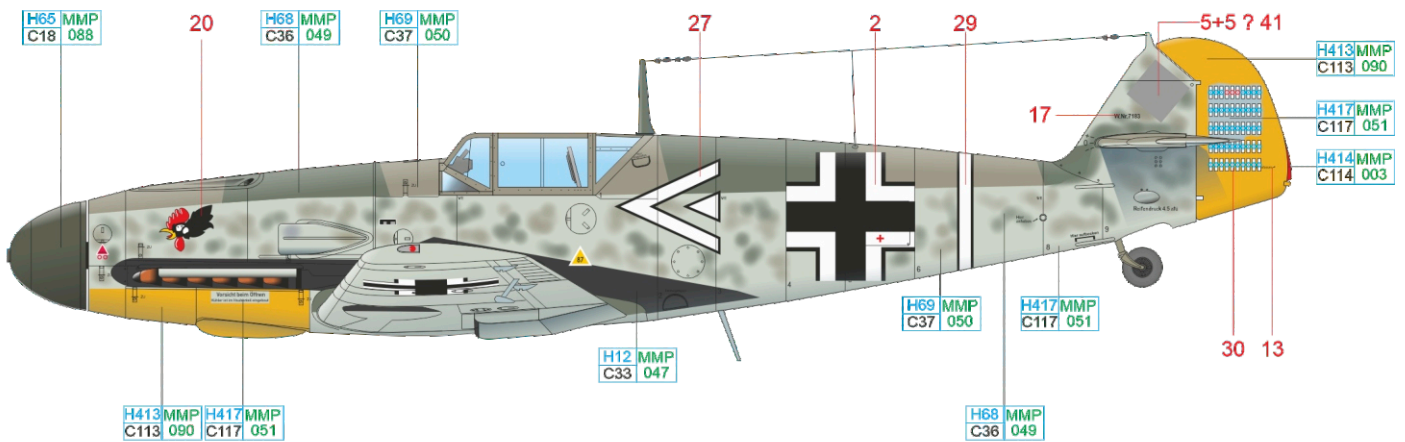

ČESKOU VERZI TEXTU NALEZNETE NA
www.eduard.com
 POD KATALOGOVÝM ČÍSLEM 82114

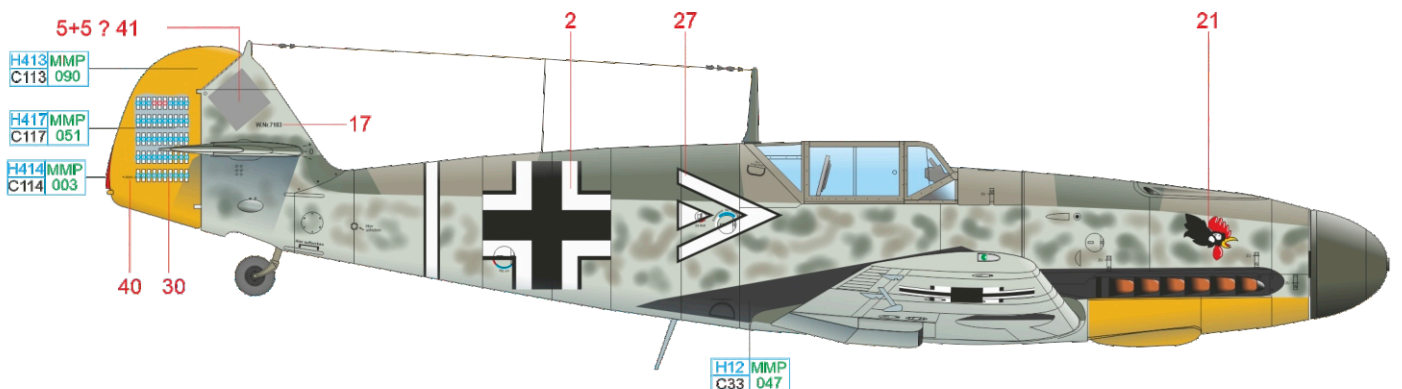
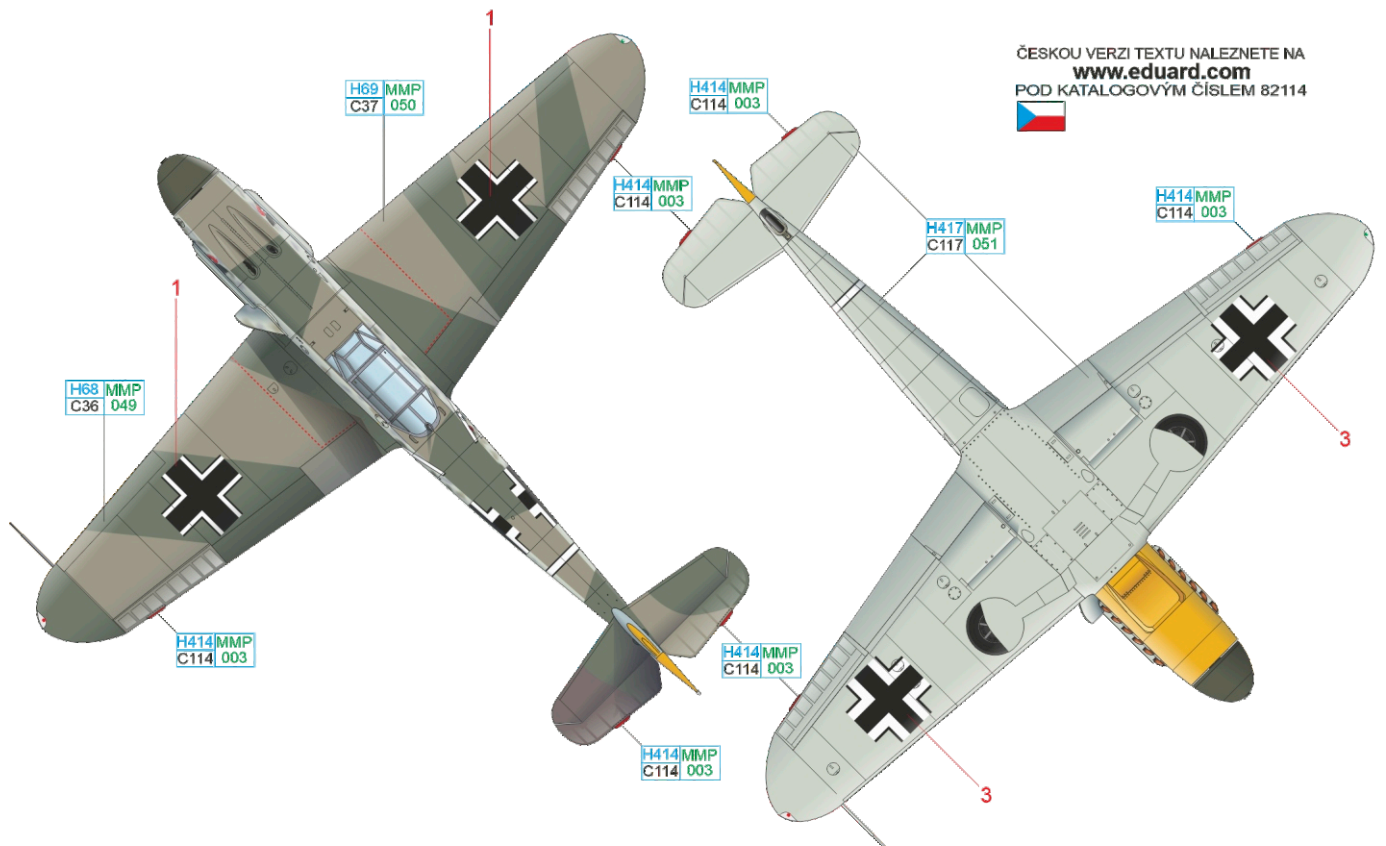

RLM 04	H413 MMP C113 090	RLM 70	H65 MMP C18 088	RLM 23	H414 MMP C114 003
BLACK	H12 MMP C33 047	RLM 74	H68 MMP C36 049	RLM 75	H69 MMP C37 050
				RLM 76	H417 MMP C117 051

B Bf 109F-4, Uffz. Hans Döbrich, 6./JG 5, Petsamo, Finland, September 2, 1942

This aircraft was flown by Hans Döbrich, a fighter ace credited with 65 victories. He was downed three times and seriously wounded during the last incident. He never flew a combat sortie again. During the second half of 1942, II./JG 5 was equipped with "Friedrichs" manufactured for service in a tropical environment. The desert camouflage colors consisting of RLM 79 and RLM 78 were applied at the factory. Feldflugpark (Repair Field Unit) in Pori added segments of RLM 74/70 (some sources state RLM 75/71) which helped to camouflage effect over the northern territory. The green shamrock on the cowling was a crest of 6./JG 5.

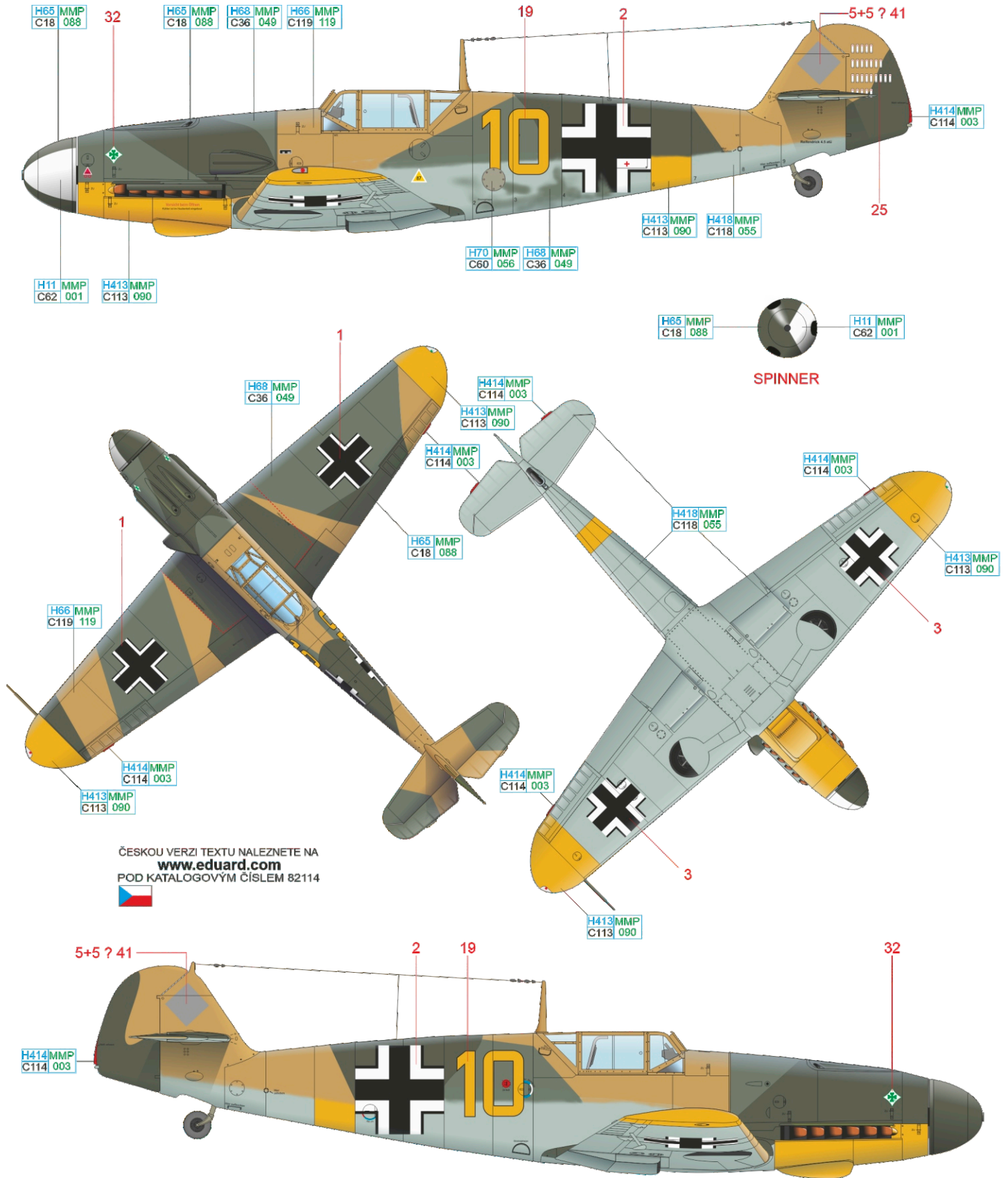

RLM 04	H413 MMP C113 090	RLM 70	H65 MMP C18 088	RLM 23	H414 MMP C114 003	RLM 02	H70 MMP C60 056
RLM 79	H66 MMP C119 119	RLM 74	H68 MMP C36 049	RLM 78	H418 MMP C118 055	WHITE	H11 MMP C62 001

C Bf 109F-4, WNr. 7243, Oblt. Otto Kath, Stab/JG 54, Staraya Russa, Soviet Union, early December 1941

Otto Kath served as Geschwaderadjutant for Hannes Trautloft, the famous fighter ace and CO of JG 54 from March, 1941 till September, 1943. Trautloft retained Kath when moving from I./JG 20 to JG 54. Kath is credited with 6 kills. The standard camouflage of RLM 74/75/76 was oversprayed with washable white paint on the upper sides as the temporary winter camouflage. The only exception was the framing of the canopy. The non-standard Geschwader Stab marking is green, which was the color reserved for aircraft of the HQ members. The green heart was the symbol of the JG 54 "Grünherz". Note the yellow Eastern Front markings on the wings, rudder, and fuselage.

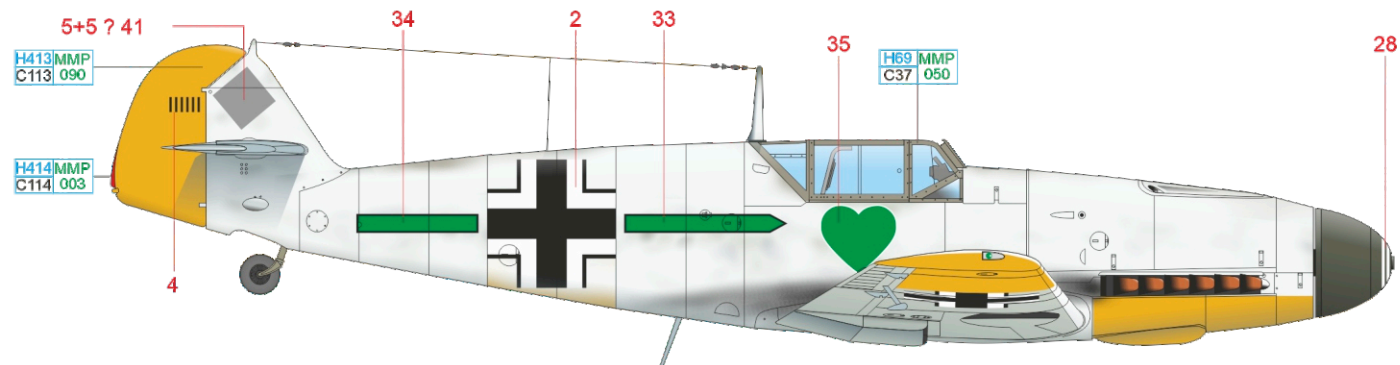
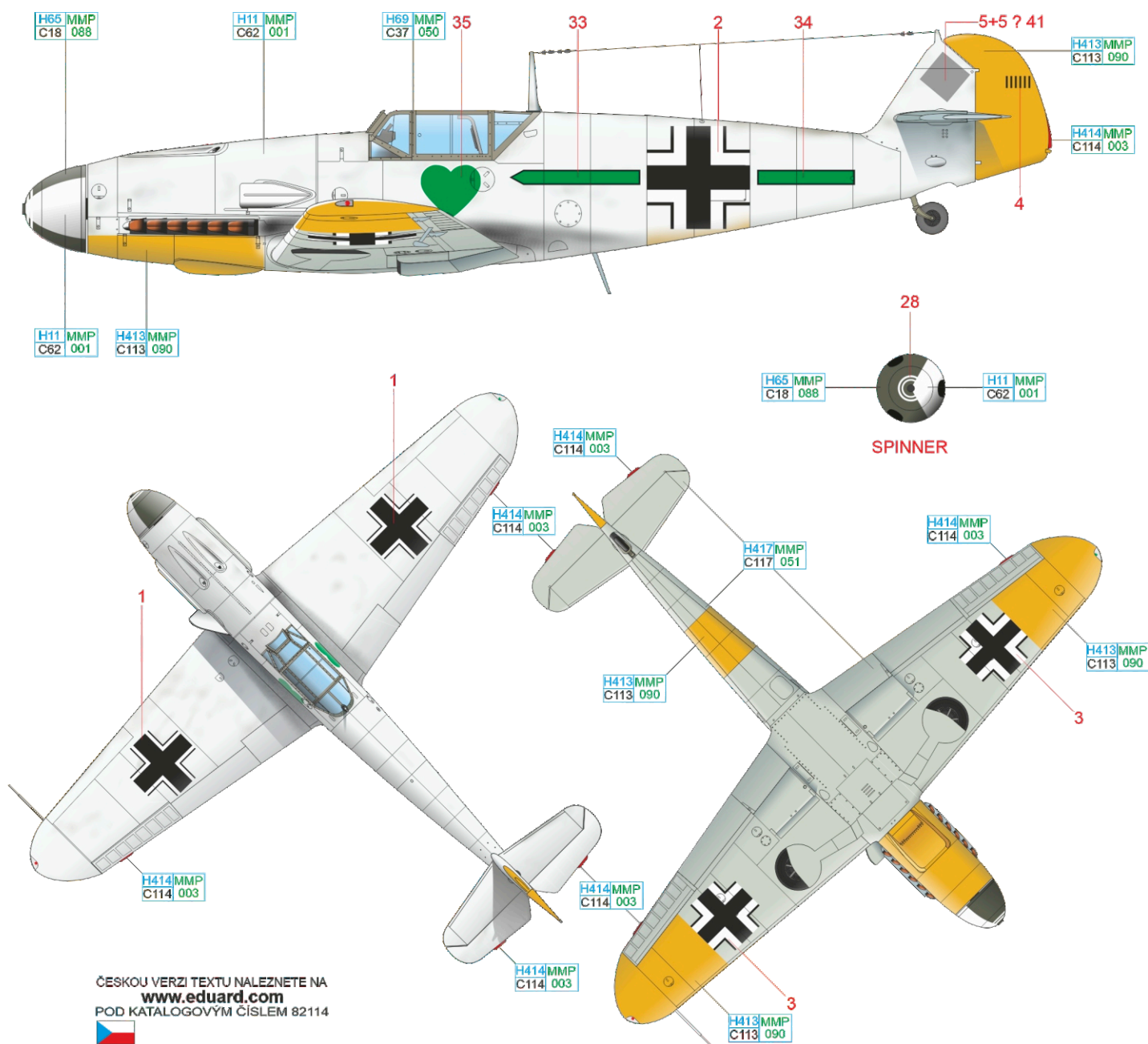

WHITE	H11 MMP C62 001	RLM 75	H69 MMP C37 050
RLM 04	H413 MMP C113 090	RLM 70	H65 MMP C18 088
		RLM 23	H414 MMP C114 003
		RLM 76	H417 MMP C117 051

D Bf 109F-4/trop, WNr. 8693, Lt. Hans-Joachim Marseille, 3./JG 27, North Africa, February 1942

This aircraft was flown by Lt. Hans-Joachim Marseille, a fighter ace with 158 kills to his credit. Marseille was awarded the Knight's Cross with Swords, Oak Leaves and Diamonds as the recognition of his remarkable success. He was shooting down enemy aircraft at rapid rate with many multiple one-day victories. The German propaganda made use of it to make Marseille a star. The tale ended with Marseille's death. He was killed in accident on September 30, 1942. The camouflage of his aircraft consisted of RLM 79 "Sandgelb" on the upper surfaces and RLM 78 "Himmelblau" on the lower ones. The rudder was adorned with fifty kill marks (Abschussmarken) and appears to be oversprayed with a red-brown primer. Marseille achieved his 49th and 50th kills on February 21, 1942. His victims were two Kittyhawks. The white-painted wingtips and fuselage band were Luftwaffe markings used on the aircraft flown in the Mediterranean theatre.

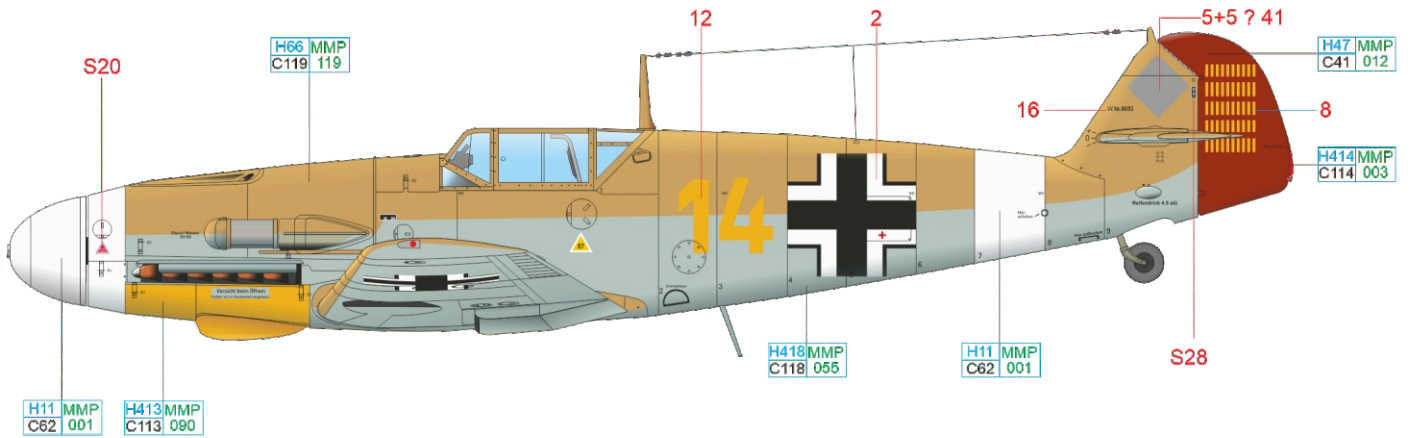

ČESKOU VERZI TEXTU NALEZNETE NA
www.eduard.com
 POD KATALOGOVÝM ČÍSLEM 82114

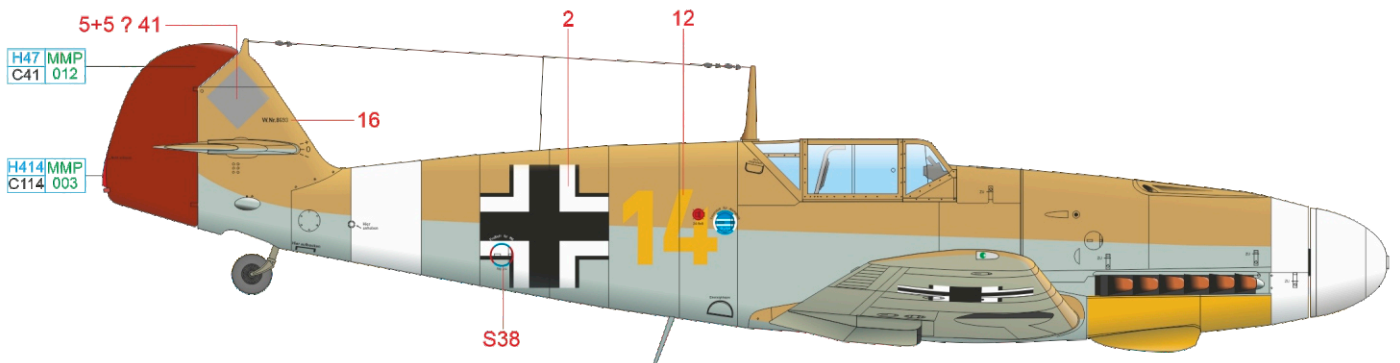
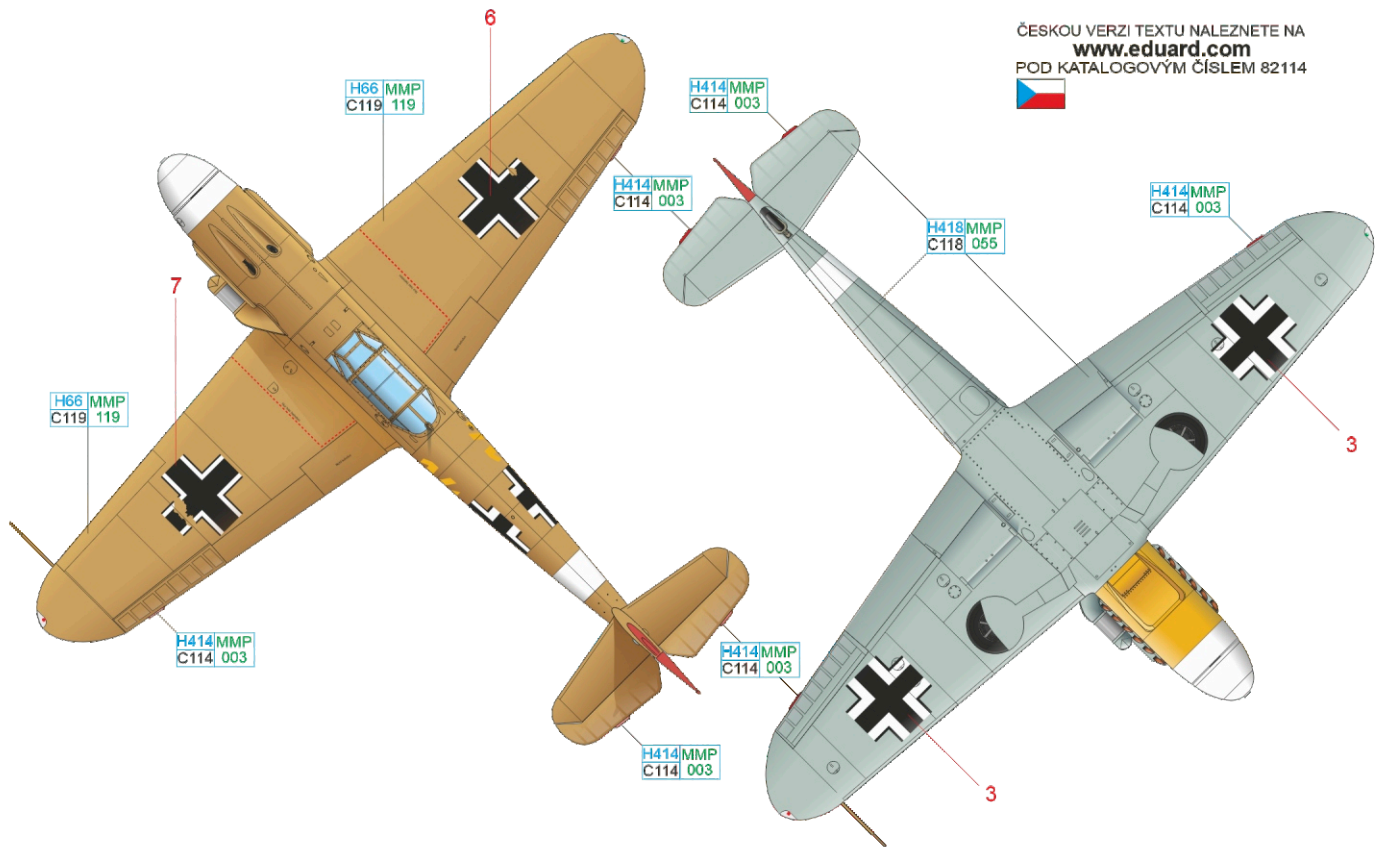

WHITE	H11 MMP C62 001	RLM 23	H414 MMP C114 003
RLM 04	H413 MMP C113 090	RLM 79	H66 MMP C119 119
		RED BROWN	H47 MMP C41 012
			RLM 78 H418 MMP C118 055

During late 1941, the Luftwaffe considered renewing bombing of Great Britain and coastal shipping. Each fighter unit fighting against the Great Britain was ordered to single out one Staffel for this purpose. The 10. (Jabo) Staffel played this role within JG 2. Under command of Oblt. Frank Liesendahl this Staffel sank 20 vessels (total tonnage 630,000 BRT) over a four-month period. Liesendahl was killed when attacking cargo vessels near Brixham on July 17, 1942. Posthumously he was promoted to Hauptmann rank and was awarded the Knight's Cross as well. Liesendahl's personal mount wore a standard day fighter camouflage consisting of RLM 74/75/76. The ship-munching fox was a 10. (Jabo) Staffel badge. Note the symbols of vessels damaged or sunk by Liesendahl on the rudder.

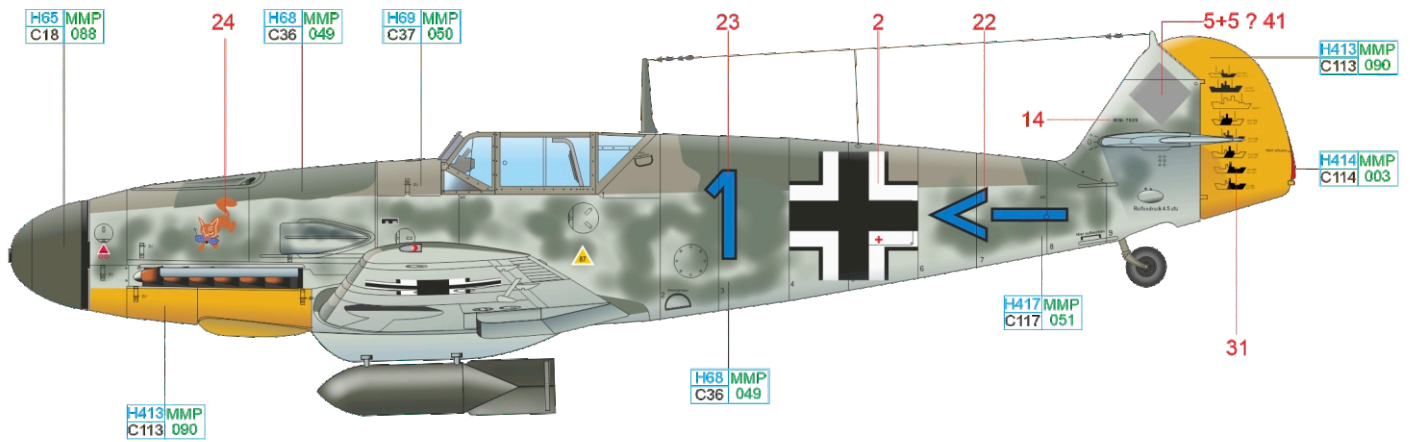

ČESKOU VERZI TEXTU NALEZNETE NA
www.eduard.com
 POD KATALOGOVÝM ČÍSLEM 82114

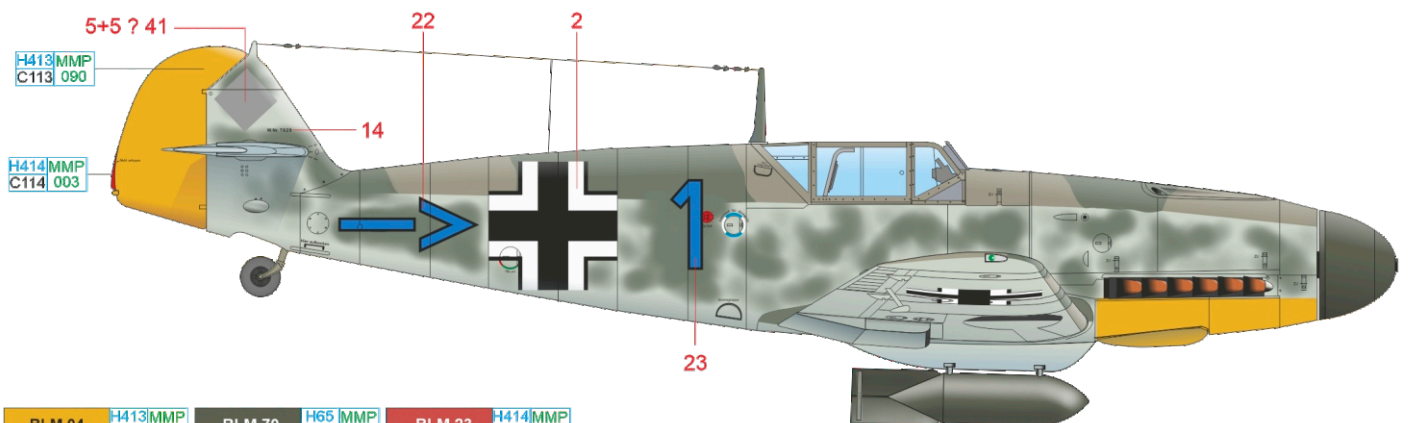
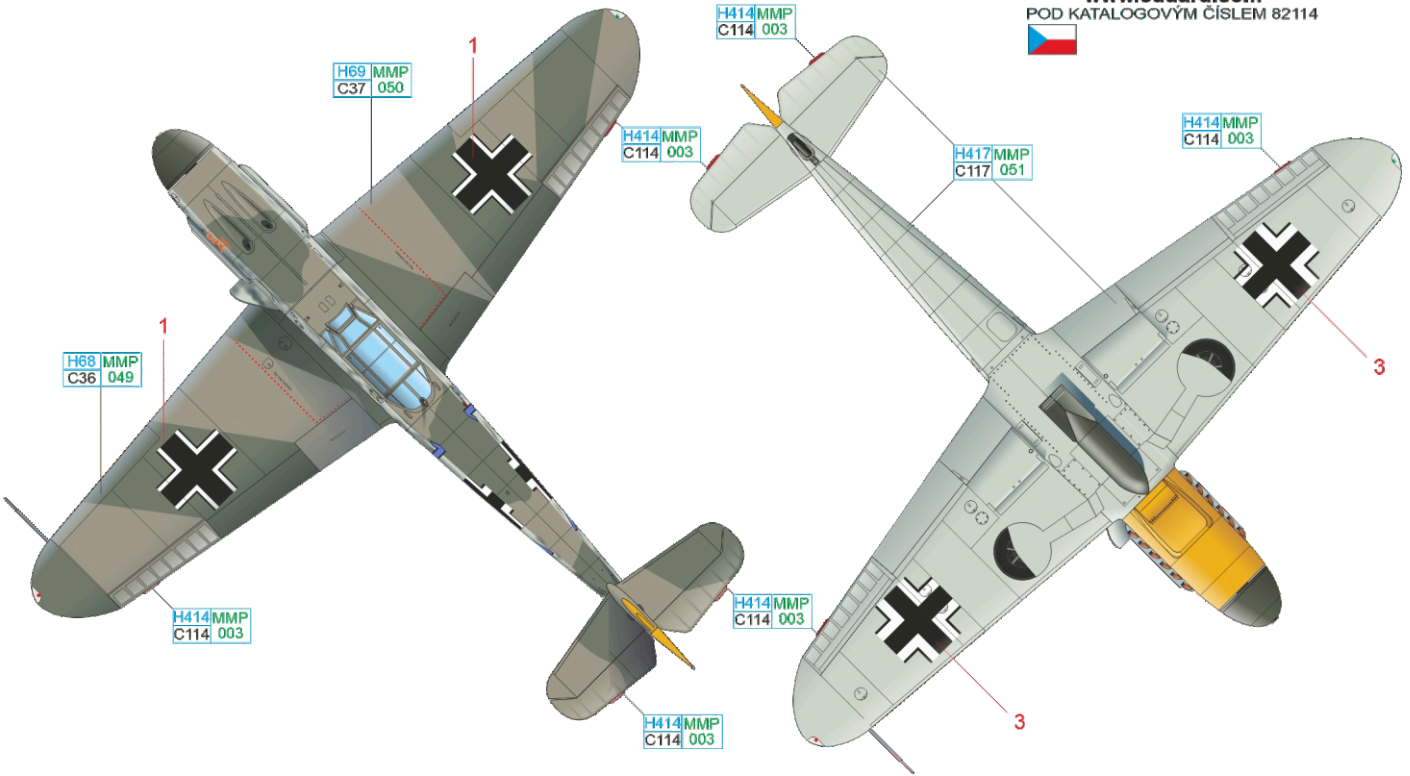

RLM 04	H413 MMP C113 090	RLM 70	H65 MMP C18 088	RLM 23	H414 MMP C114 003
RLM 74	H68 MMP C36 049	RLM 75	H69 MMP C37 050	RLM 76	H417 MMP C117 051

F Bf 109F-4, WNr. 13325, Oblt. Viktor Bauer, 9./JG 3, Shchigry, Soviet Union, June 1942

This aircraft was flown by Viktor Bauer, holder of the Knight's Cross with an oak leaves and ace with 106 kills. He achieved most of them in combats with Soviet pilots. Bauer flew this particular aircraft in the summer of 1942, when German Group of Armies A advanced on Stalingrad. The unit received Messerschmitts originally intended for service in North Africa, thus camouflaged in RLM 78/79 colors. The segments of RLM 74/70 (some sources state RLM 75/71) were added to the desert camouflage scheme to better the camouflage effect in the Eastern Front environment. The yellow wingtips, fuselage band and lower cowling were typical for airplanes flown in the east. Note the III./JG 3 badge on the nose. The name Ellen referred to Bauer's wife. Bauer achieved his 106th and last kill on August 9, 1942, northwest of Stalingrad. The very next day he was hit by enemy fire, wounded, and had to belly land his crippled plane. After rescue, Bauer served in various posts of Ergänzungs (replacement) units.

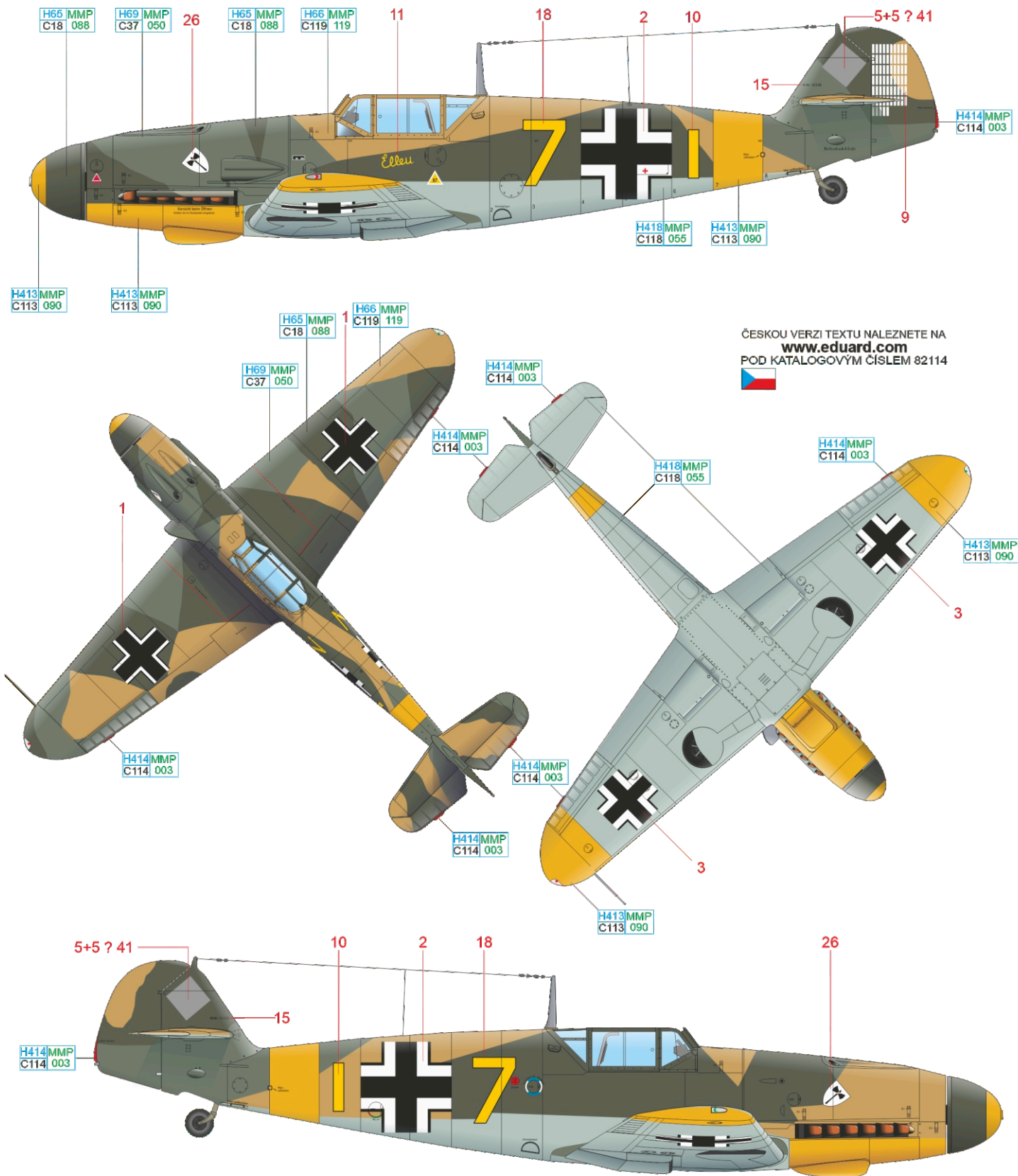

RLM 04	H413 MMP C113 090	RLM 70	H65 MMP C18 088	RLM 23	H414 MMP C114 003
RLM 79	H66 MMP C119 119	RLM 74	H68 MMP C36 049	RLM 78	H418 MMP C118 056

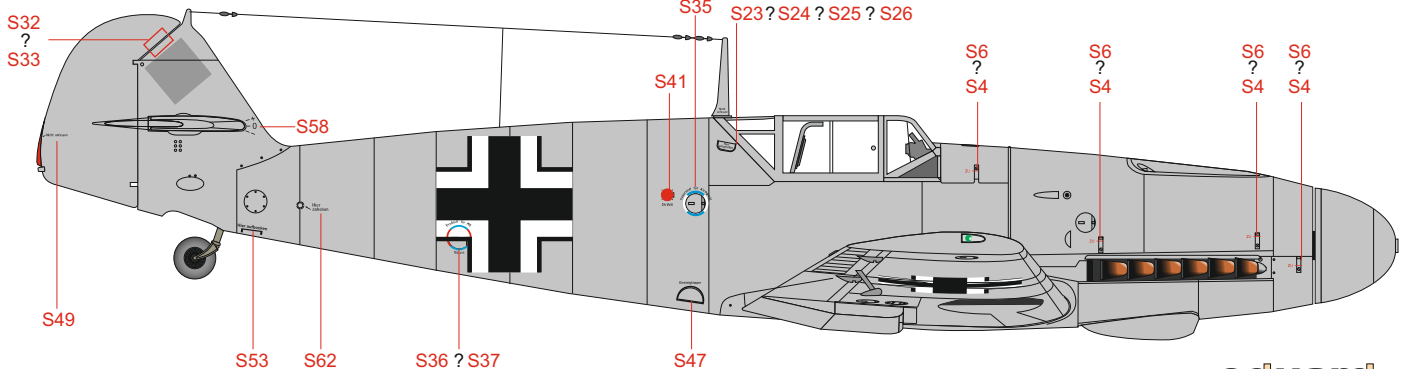
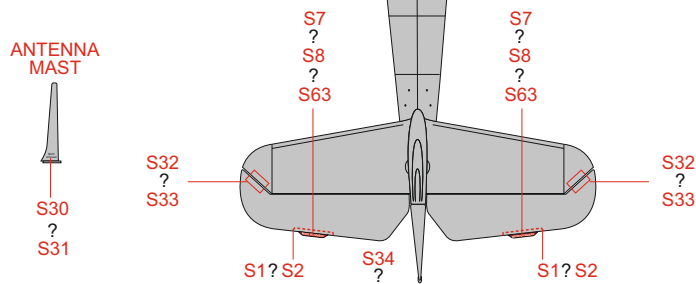
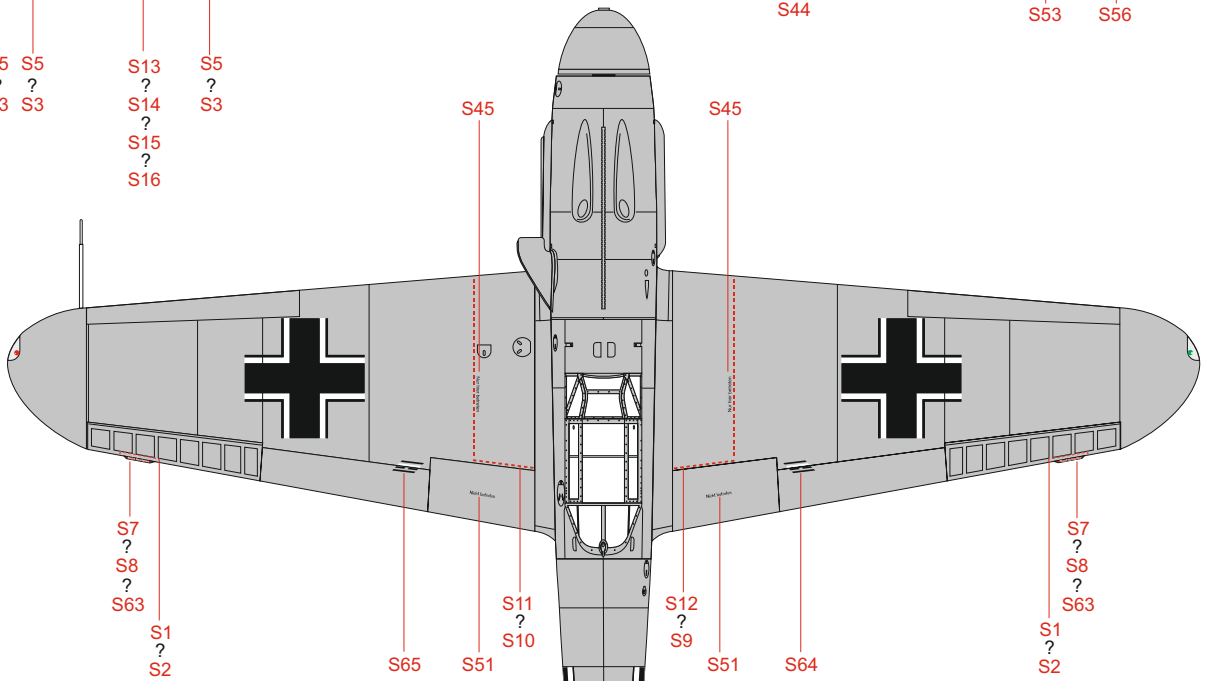
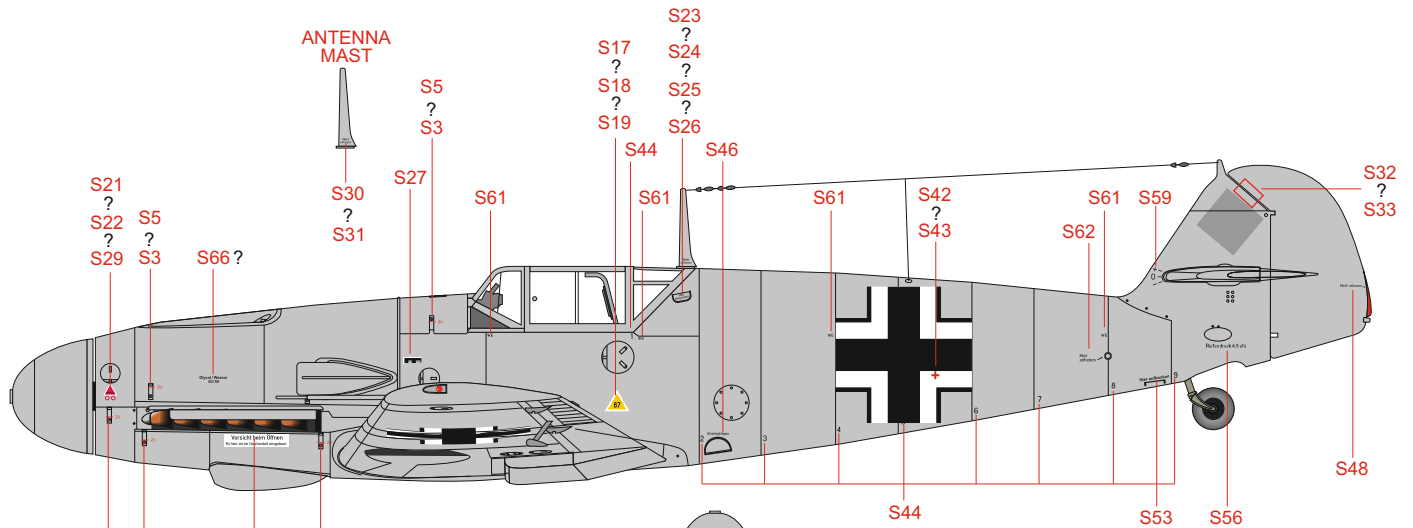

- 48899 Bf 109F-4 (PE-Set)
- 49095 Seatbelts Luftwaffe WWII fighters STEEL (PE-Set)
- 644010 Bf 109F LööK (Brassin)
- 648279 Bf 109F cockpit (Brassin)
- 648282 Bf 109F wheels (Brassin)
- 648288 Bf 109F propeller LATE (Brassin)
- 648289 Bf 109F propeller EARLY (Brassin)
- 648291 Bf 109F landing flaps (Brassin)
- 648292 Bf 109F control surfaces (Brassin)
- 648300 Bf 109F engine and fuselage guns (Brassin)
- 648308 Bf 109F undercarriage legs BRONZE (Brassin)
- 648332 Bf 109F&G Pitot tubes (Brassin)
- 648365 Bf 109F radio compartment (Brassin)
- EX588 Bf 109F TFace 1/48 (maska)

Cat. No. 644010



Cat. No. 648300

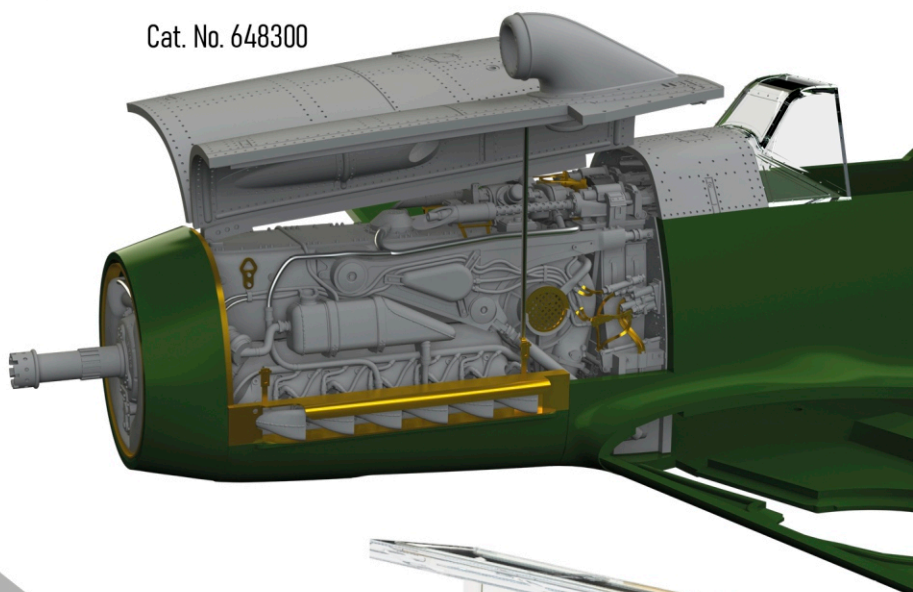

Cat. No. 648365

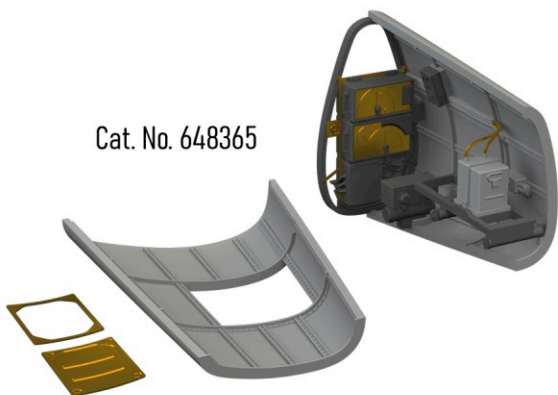

Cat. No. 648292

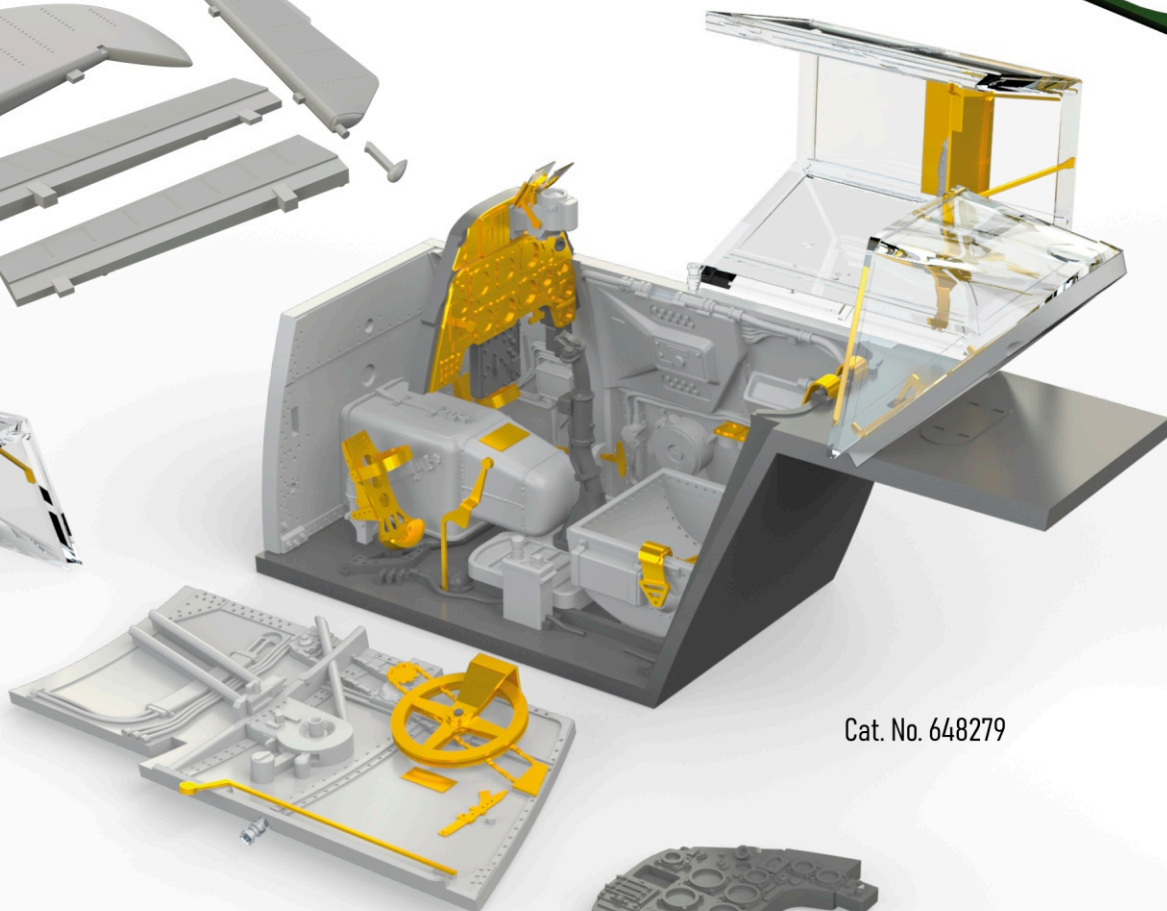
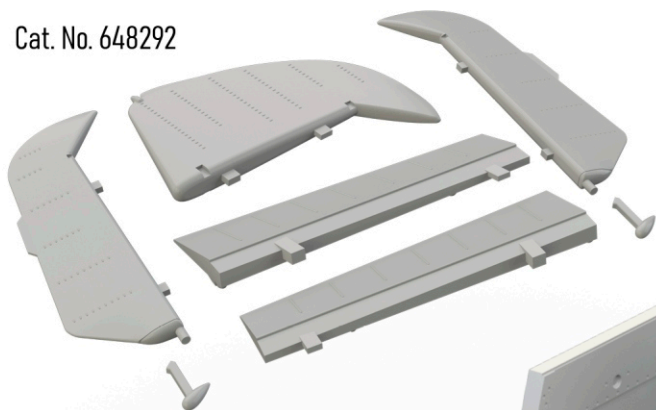

Cat. No. 648279



Fw 190F-8

eduard



1/48

ProfiPACK
edition

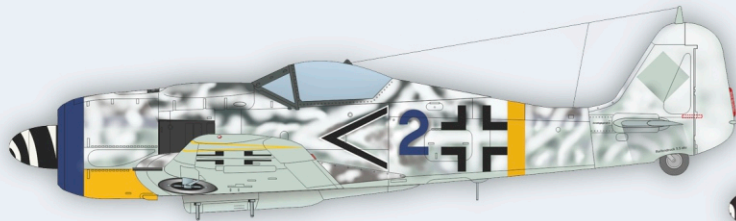

Stab I./SG 2, Csar or Raab, Hungary, winter 1944/1945

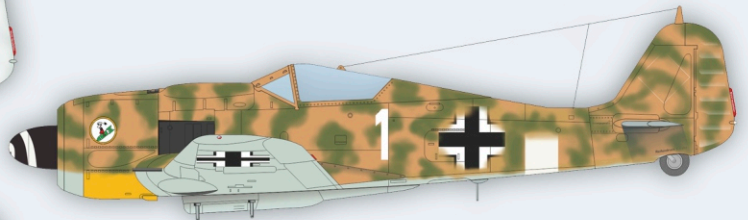

1./SG 4, Airasca, Italy, June 1944



W.Nr. 586188, Stab III./SG 10, Hohenmauth (Vysoké Mýto),
Protectorate Böhmen und Mähren, May 1945

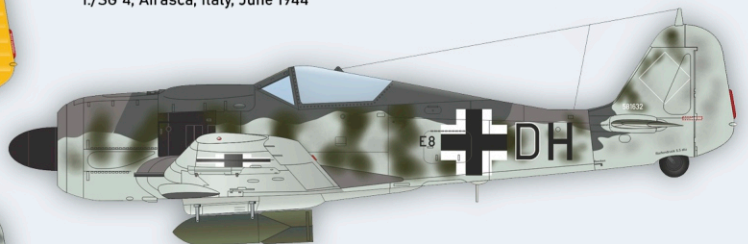

W.Nr. 581632, 1./NSGr. 9, Villafranca di Verona, Italy, May 1945

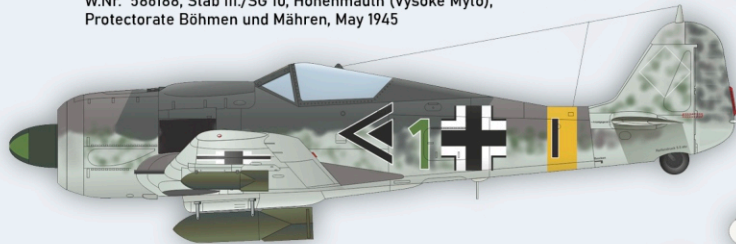

Major Karl Schrepfer, CO of III./SG 1, Kraków, Poland,
August 1944



Stab SG 77, Schönfeld-Seifersdorf (Łukaszów), Silesia, August 1944



W.Nr. 584205, III./SG 3, Sabile (Zabeln), Latvia, May 1945