

# MiG-21SMT

eduard

SOVIET SUPERSONIC FIGHTER

1/48 SCALE PLASTIC KIT

ProfiPACK  
edition

#8233



## INTRO

The MiG-21 was one of a long list of Mikoyan-Gurevich products to be integrated into the armed forces of the Soviet Union, the Warsaw Pact, and allied client states. Its predecessors included such notable types as the MiG-15, MiG-17 and the supersonic MiG-19. The roots of this project reach back to the first half of the fifties. In 1954, the Ye-1 project came to an end, and was quickly picked up by the Ye-2. Both had a swept wing. The first machine to feature the delta wing was the Ye-4, which first took to the air on June 16th, 1955. It was also demonstrated a year later at the Moscow airfield Tushino. The first of the new line to enter production was the MiG-21F, which together with the MiG-21P and F-13 represented the first generation of the MiG-21, and was in production through the end of the fifties and the beginning of the sixties. Subsequent versions included the PF, FL, PFM, R, etc, the production of which peaked at the end of the sixties. The third generation started production in 1968, which included such versions as M, SM, MF, SMT, bis among others. Simultaneously, two-seat training versions were also produced designated MiG-21U, UM and US. Production of the MiG-21 ended in 1985, and was put into service with some fifty nations.

Over the course of the cold war, the opponents of the MiG-21 included the likes of the Northrop F-5 Freedom Fighter and the Dassault Mirage III. NATO assigned it the reporting name 'Fishbed'. It became the most produced supersonic fighter in terms of quantity. The new machines came off Soviet production lines in Moscow, Gorky and Tbilisi. The MiG-21F-13 was also built under license in Czechoslovakia and the MiG-21FL, M and bis in India by Hindustan Aeronautics Ltd. The Soviet Union produced 10,645 examples of all versions, 194 were built in Czechoslovakia and 657 in India. Outside of the Soviet Union, the type flew with a long list of nations on all continents with the exception of Australia. The MiG-21 participated in combat in Vietnam, the Indo-Pakistan wars, the Cuban participation in Angola and in the Arab world's attempt to eliminate Israel. Thanks to the high volume of use, the highest number of aces produced on the type was in Vietnam. The top of the ladder is occupied by Nguyen Van Coc with nine kills. The type serving as a fighter-bomber served with the Soviet Union and other nations of the Warsaw Pact into the eighties, when it began to be displaced by the MiG-29 Fulcrum.

This kit allows you to build foremost a model of the MiG-21MT or SMT. In factory documentation, the types are identified as Izdelye 50 for SMT and Izdelye 96B for MT. They were powered by the Tumansky R-13F-300 with afterburning and carried the Saphir-21/RP-22SM radar. The armament was composed of the GS-23-2L 23mm cannon with 200 rounds. The underwing pylons could carry a combination of FAB bombs up to 500kg in size, UB-16-57 or UB-32A rocket pods, and R-3S, R-3R or S-24 missiles. NATO assigned the MiG-21MT / SMT the codename 'Fishbed K'.

## ÚVODEM

MiG-21 byl další konstrukcí kanceláře Mikojan-Gurjevič, která se zařadila do výzbroje Sovětského svazu, zemí Varšavské smlouvy a dalších ozbrojených sil. Jeho předchůdci byly tak významné typy jako MiG-15, MiG-17 či nadzvukový MiG-19. Kořeny vývoje letounu sahají do první poloviny 50. let minulého století. V roce 1954 byl dokončen projekt Je-1, velmi rychle nahrazený druhým prototypem Je-2. Oba měly šípové křídlo. Prvním strojem s delta křídlem byl prototyp Je-4, který se do vzduchu dostal poprvé 16. června 1955. Představil se také na letecké přehlídce, která se konala o rok později na moskevském letišti Tušino. Jako první se do sériové výroby dostala verze MiG-21F, která společně s MiG-21P a MiG-21F-13 reprezentovala první generaci tohoto typu, vyráběnou na přelomu 50. a 60. let minulého století. Následovaly další, pokročilejší verze – PF, FL, PFM, R atd., jejichž produkce vyvrcholila v druhé polovině 60. let. Od roku 1968 probíhala výroba třetí generace, která zahrnovala například verze M, SM, MF, SMT, bis a další. Souběžně se stavěly také dvoumístné cvičné jednadvacítky MiG-21U, UM a US. Výroba MiGů-21 skončila v roce 1985 a do výzbroje je zařadilo okolo 50 zemí světa.

MiG-21 měl během studené války své protějšky v typech Northrop F-5 Freedom Fighter či Dassault Mirage III. Vojska NATO dalo typu kódové označení Fishbed. Stal se v největších počtech vyráběným nadzvukovým letounem. Nové stroje v Sovětském svazu sjížděly z továrních linek v Moskvě, Gorkém a Tbilisi. V licenci se stavěla verze MiG-21F-13 v Československu a MiG-21FL, M a bis v Indii u Hindustan Aeronautics Ltd. V Sovětském svazu vzniklo 10 645 exemplářů všech verzí, v Československu 194 kusů a v Indii 657 strojů.

Kromě ozbrojených sil Sovětského svazu létal s řadě zemí, s výjimkou Austrálie na všech kontinentech. Zúčastnil se řady válečných konfliktů, včetně války ve Vietnamu, indicko-pákistánských potyček, kubánského tažení v Angole či arabské snahy o zničení Izraele. Díky největšímu zapojení do bojových akcí se největší počet stíhacích es zrodil ve Vietnamu. Na čele žebříčku stojí Nguyen Van Coc s devíti sestřely. V roli přepadového stíhacího letounu sloužily MiGy-21 v Sovětském svazu a dalších zemích Varšavské smlouvy až do 80. let, kdy jej jako plnohodnotná náhrada začaly z prvoliniové služby vytlačovat nové MiGy-29 Fulcrum.

Z této stavebnice si můžete postavit modely letounů MiG-21MT a SMT. V tovární dokumentaci figurují pod označením Izdělje 50 pro SMT a Izdělje 96B pro MT. Poháněl je motor Tumanskij R-13F-300 s přídavným spalováním a nesly radar Safir-21/RP-22SM. Výzbroj tvořil dvouhlavňový kanon GŠ-23-2L ráže 23 mm se zásobou 200 ran. Na závěsníky bylo možné podvěsit kombinaci pum FAB až do ráže 500 kg, raketnic UB-16-57, UB-32A a raket R-3S, R-3R či S-24. V kódu NATO nesly MiGy-21MT a SMT označení Fishbed K.

## E MiG-21SMT, 296<sup>th</sup> IAP, Soviet Union

FOR COMPLETE PROFILE PLEASE REFER  
KOMPLETNÍ KAMUFLÁŽNÍ SCHEMA  
NALEZNETE NA  
[www.eduard.com](http://www.eduard.com)

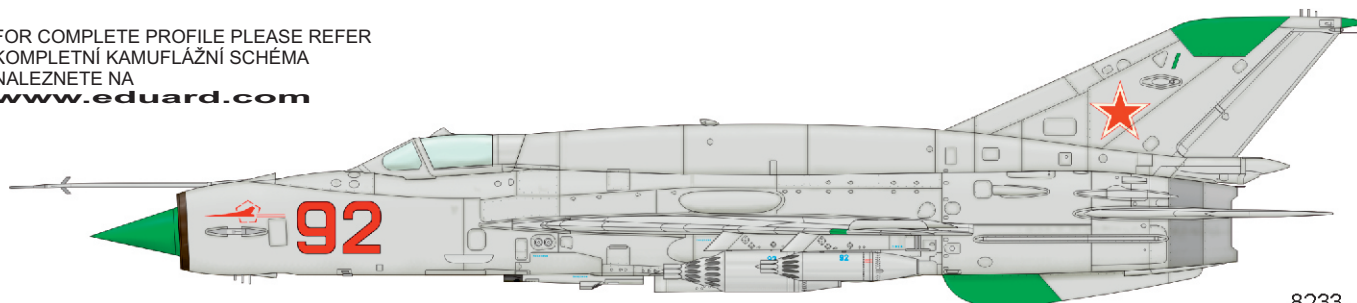

8233 - NAV1



Carefully read instruction sheet before assembling. When you use glue or paint, do not use near open flame and use in well ventilated room. Keep out of reach of small children. Children must not be allowed to suck any part, or pull vinyl bag over the head.



Před započítím stavby si pečlivě prostudujte stavební návod. Při používání barev a lepidel pracujte v dobře větrané místnosti. Lepidla ani barvy nepoužívejte v blízkosti otevřeného ohně. Model není určen malým dětem, mohlo by dojít k požití drobných dílů.

## INSTRUCTION SIGNS \* INSTR. SYMBOLS \* INSTRUKTION SINNBILDEN \* SYMBOLES \* 記号の説明



OPTIONAL  
VOLBA



BEND  
OHNOU



OPEN HOLE  
VYVRTAT OTVOR



SYMMETRICAL ASSEMBLY  
SYMETRICKÁ MONTÁŽ



REMOVE  
ODŘÍZNOUT



REVERSE SIDE  
OTOČIT



APPLY EDUARD MASK  
AND PAINT  
POUŽÍT EDUARD MASK  
NABARVIT

## PARTS



## DÍLY



## TEILE



## PIÈCES



## 部品

## PLASTIC PARTS

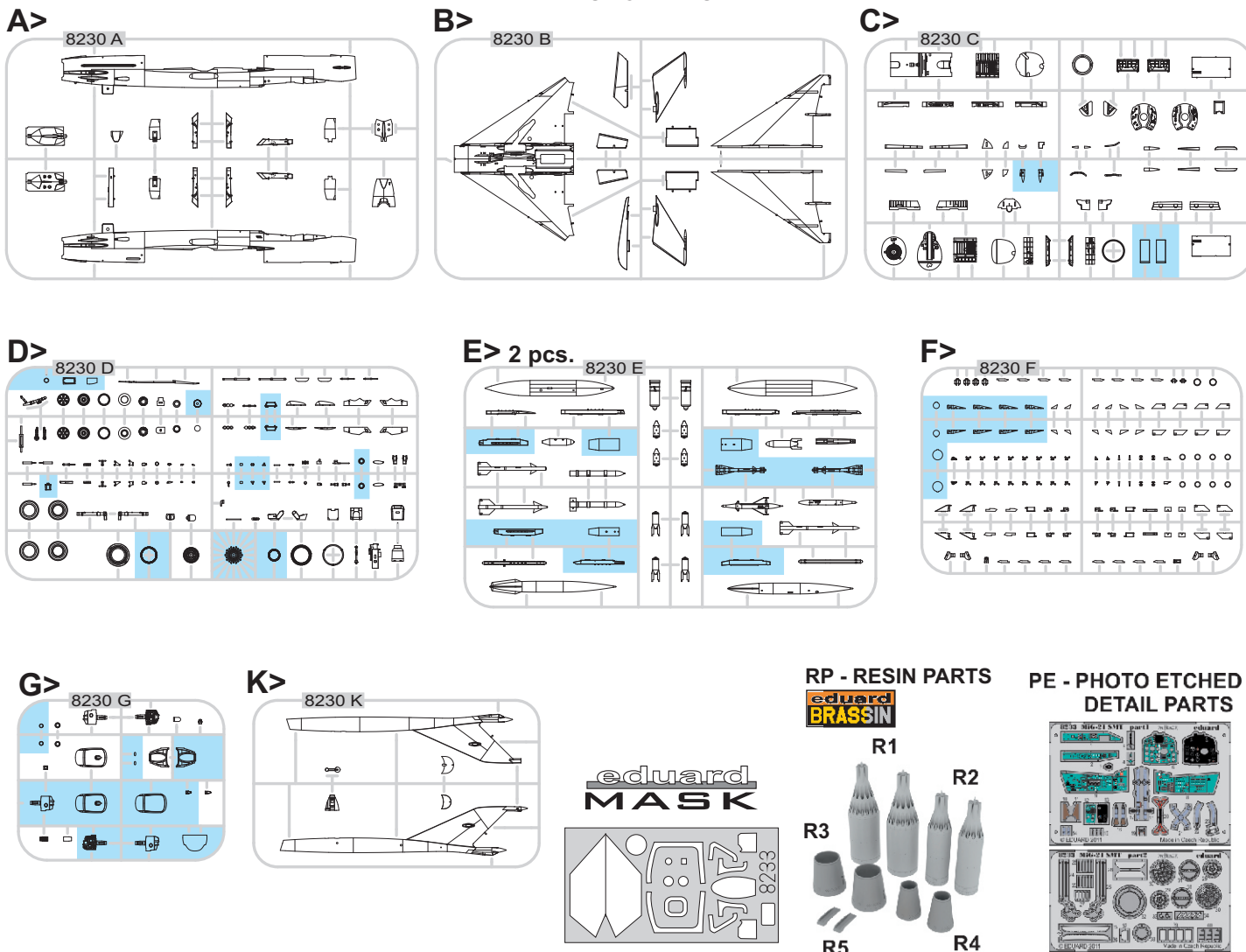

## RP - RESIN PARTS

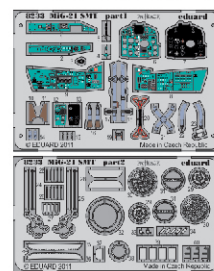
PE - PHOTO ETCHED  
DETAIL PARTS

-Parts not for use. -Teile werden nicht verwendet. -Pièces à ne pas utiliser. -Tyto díly nepoužívejte při stavbě. - 使用しない部品

## COLOURS



## BARVY



## FARBEN



## PEINTURE



## 色

GSI Creos (GUNZE)		
AQUEOUS	Mr.COLOR	
H1	C1	WHITE
H3	C3	RED
H4	C4	YELLOW
H5	C5	BLUE
H7	C7	BROWN
H8	C8	SILVER
H11	C62	FLAT WHITE
H12	C33	FLAT BLACK
H26	C66	BRIGHT GREEN
H37	C43	WOOD BROWN
H44	C51	FLESH
H47	C41	RED BROWN

AQUEOUS	Mr.COLOR	
H51	C11	LIGHT GRAY
H53	C13	NEUTRAL GRAY
H58	C27	INTERIOR GREEN
H66	C19	SANDY BROWN
H70	C60	GRAY
H72	C22	DARK EARTH
H77	C137	TIRE BLACK
H81	C55	KHAKI
H82	C32	DARK GRAY
H90	C47	CLEAR RED
H94	C138	CLEAR GREEN
H303	C303	GREEN
H304	C304	OLIVE DRAB

AQUEOUS	Mr.COLOR	
H318	C318	RADOME
H332	C332	LIGHT GRAY
H337	C337	GRAYISH BLUE
H406	C406	CHOCOLATE BROWN
	C34	SKY BLUE
	C80	COBALT BLUE
	C136	RUSSIAN GREEN
Mr.METAL COLOR		
	MC213	STAINLESS STEEL
	MC214	DARK IRON
Mr.COLOR SUPER METALLIC		
	SM06	CHROME SILVER

# INTERIOR COLOUR BARVA INTERIÉRU

## INTERIOR

60% **C34** SKY BLUE + 20% **C66** BRIGHT GREEN + 20% **C80** COBALT BLUE

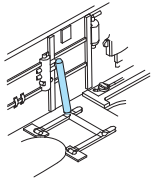

**H58** C27 INT. GREEN ? **H70** C60 GRAY **D62** ↻

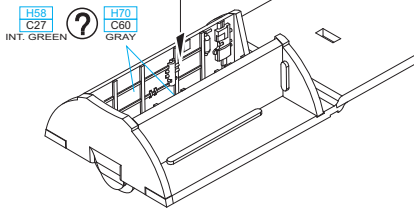

**H58** C27 INT. GREEN ? **H70** C60 GRAY

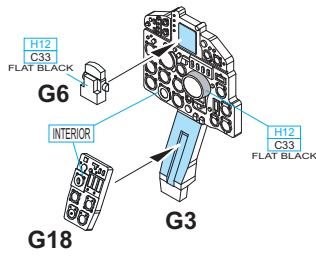

**H12** C33 FLAT BLACK **G6**

**INTERIOR**

**G3**

**H12** C33 FLAT BLACK

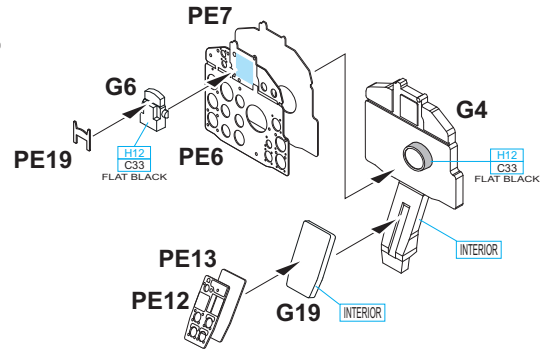

**PE7**

**G6**

**PE19**

**H12** C33 FLAT BLACK **PE6**

**G4**

**H12** C33 FLAT BLACK

**INTERIOR**

**PE13**

**PE12**

**G19**

**INTERIOR**

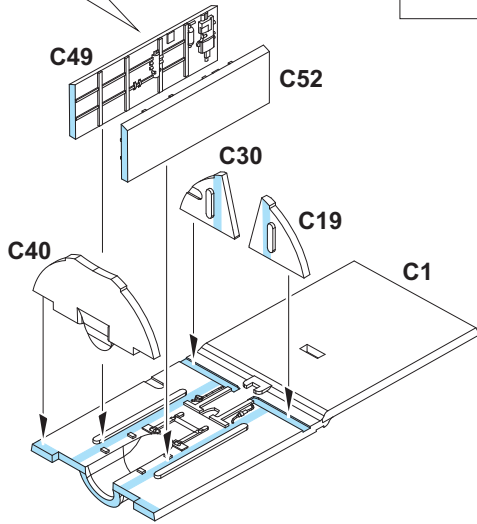
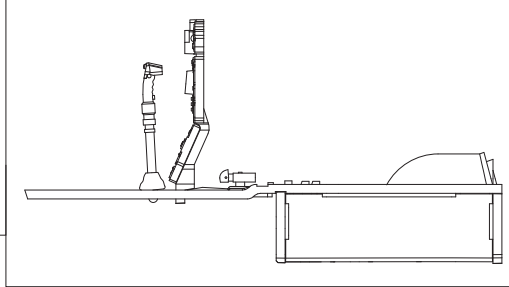

**C49**

**C52**

**C30**

**C19**

**C40**

**C1**

**D20 - OPEN CANOPY ONLY**

**D20** ?

**H12** C33 FLAT BLACK **D95**

**H47** C41 RED BROWN

**PE27** ↻

**PE27** ↻

**H8** C8 SILVER

**D75**

**INTERIOR**

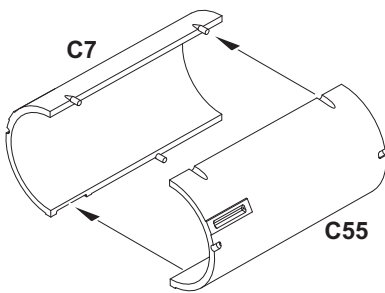

**C7**

**C55**

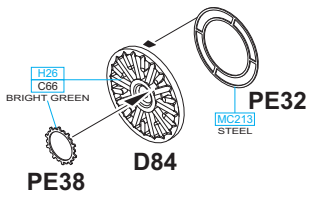

**H26** C66 BRIGHT GREEN **PE38**

**D84**

**MC213** STEEL **PE32**

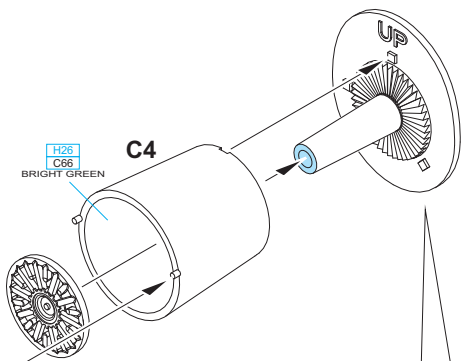

**H26** C66 BRIGHT GREEN **C4**

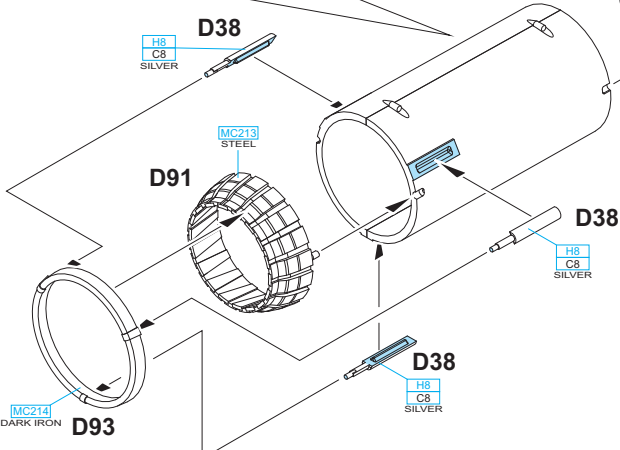

**H8** C8 SILVER **D38**

**MC213** STEEL

**D91**

**H8** C8 SILVER **D38**

**MC214** DARK IRON **D93**

**H8** C8 SILVER **D38**

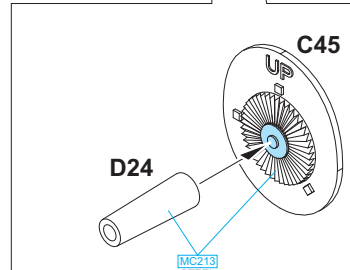

**D24**

**MC213** STEEL

**C45**

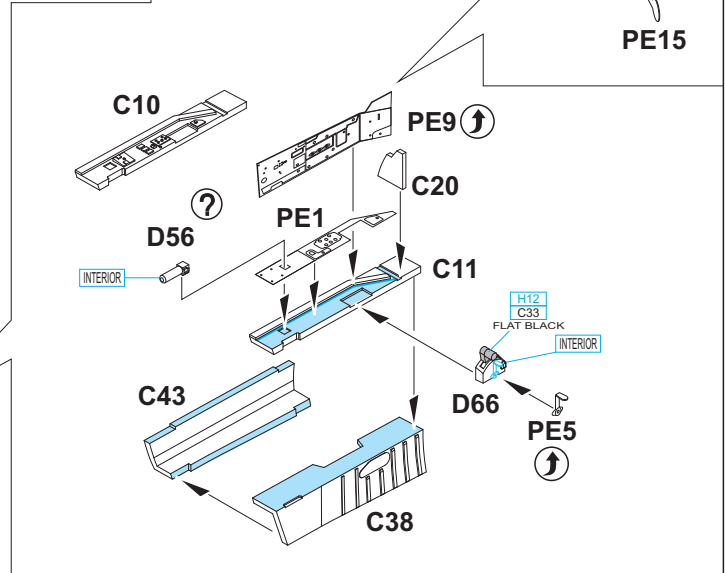
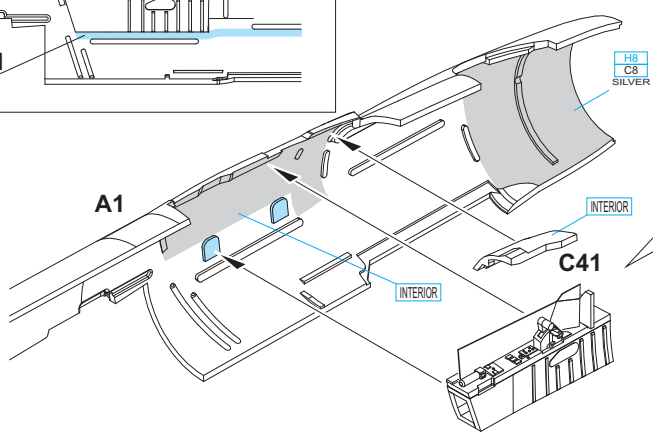
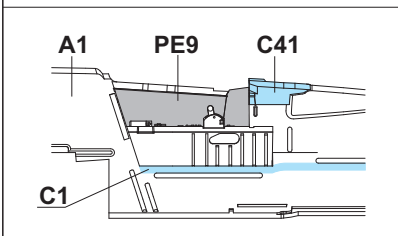
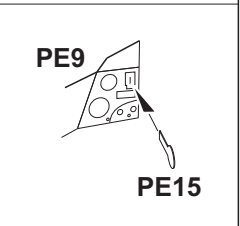
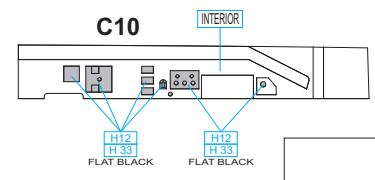
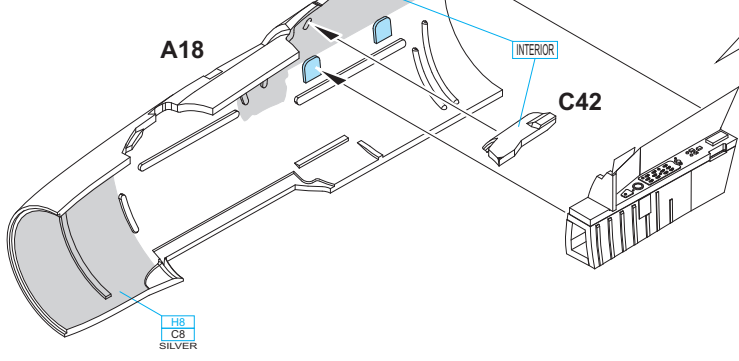
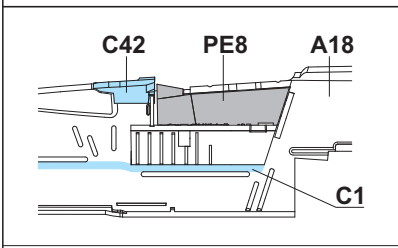
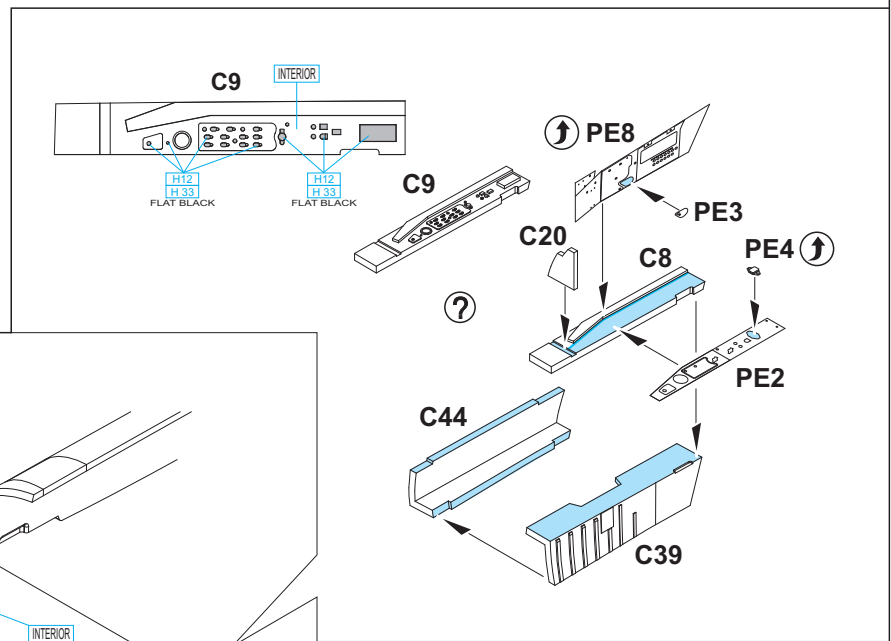
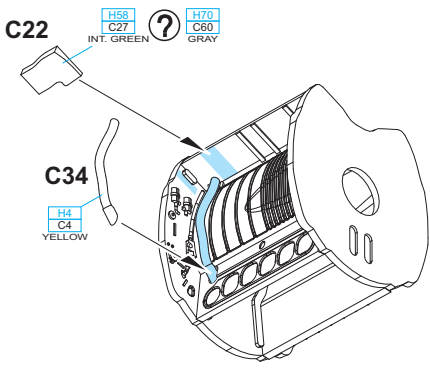
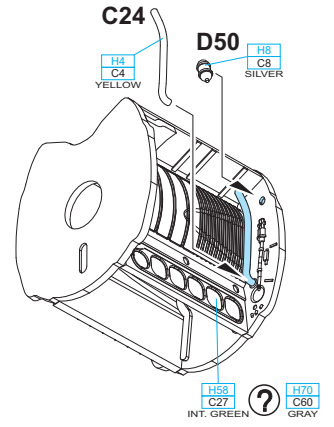
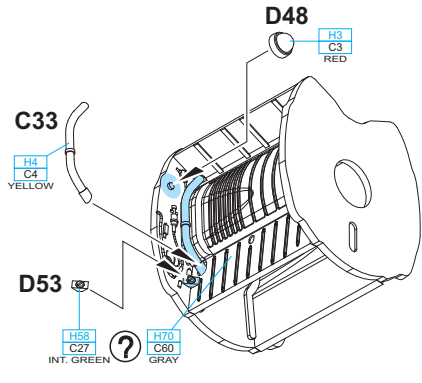
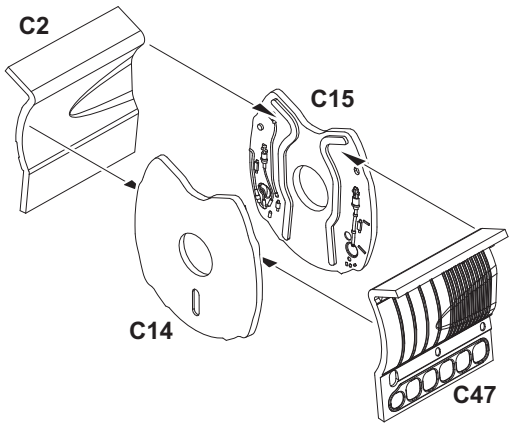

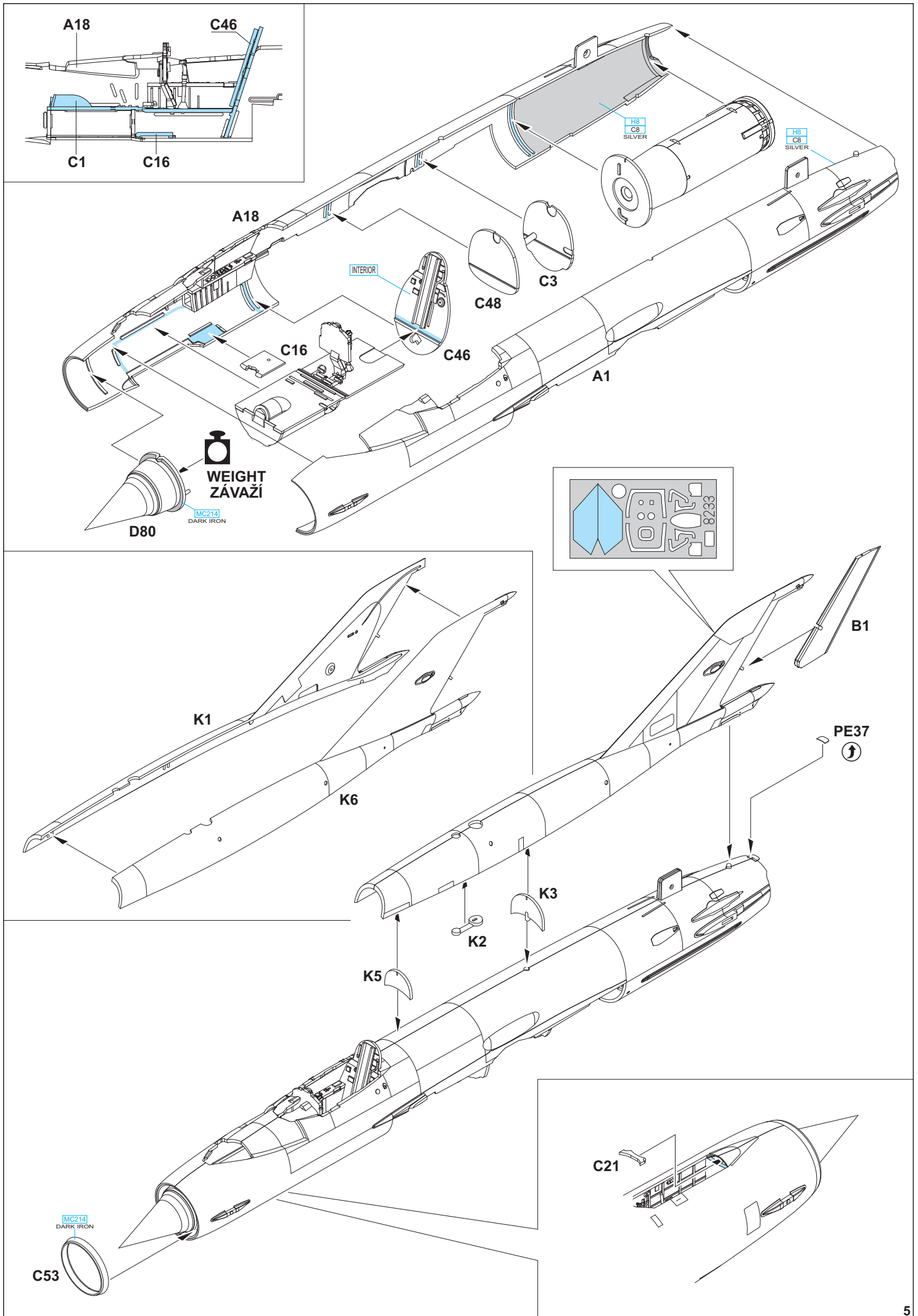

FOR OPEN AIR BRAKES ONLY  
JEN PRO OTEVŘENÉ ŠTÍTY

APPLY MASK OUTSIDE WHEN PAINTING  
MASKU POUŽIJTE Z VNĚJŠKU PŘI BARVENÍ

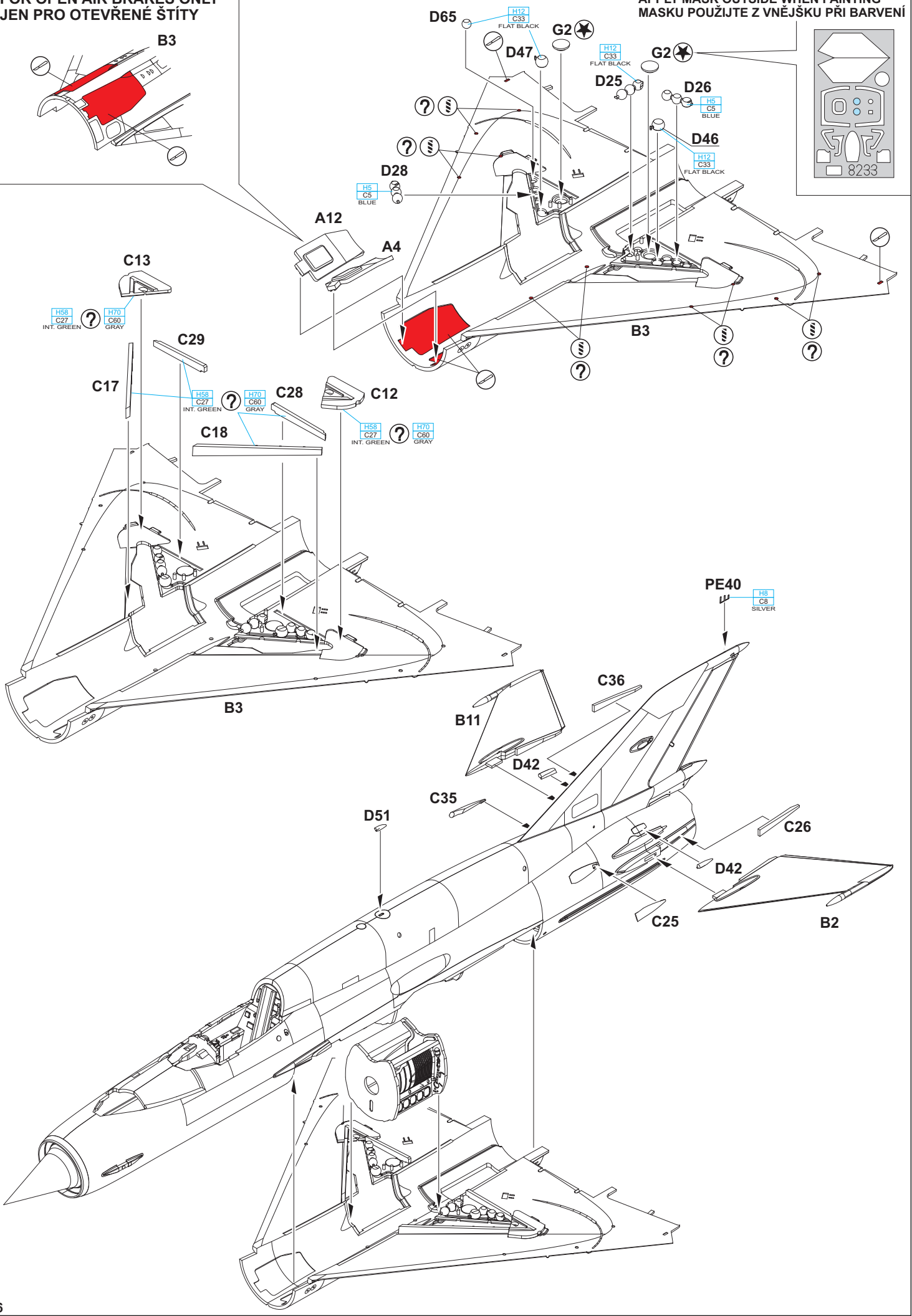

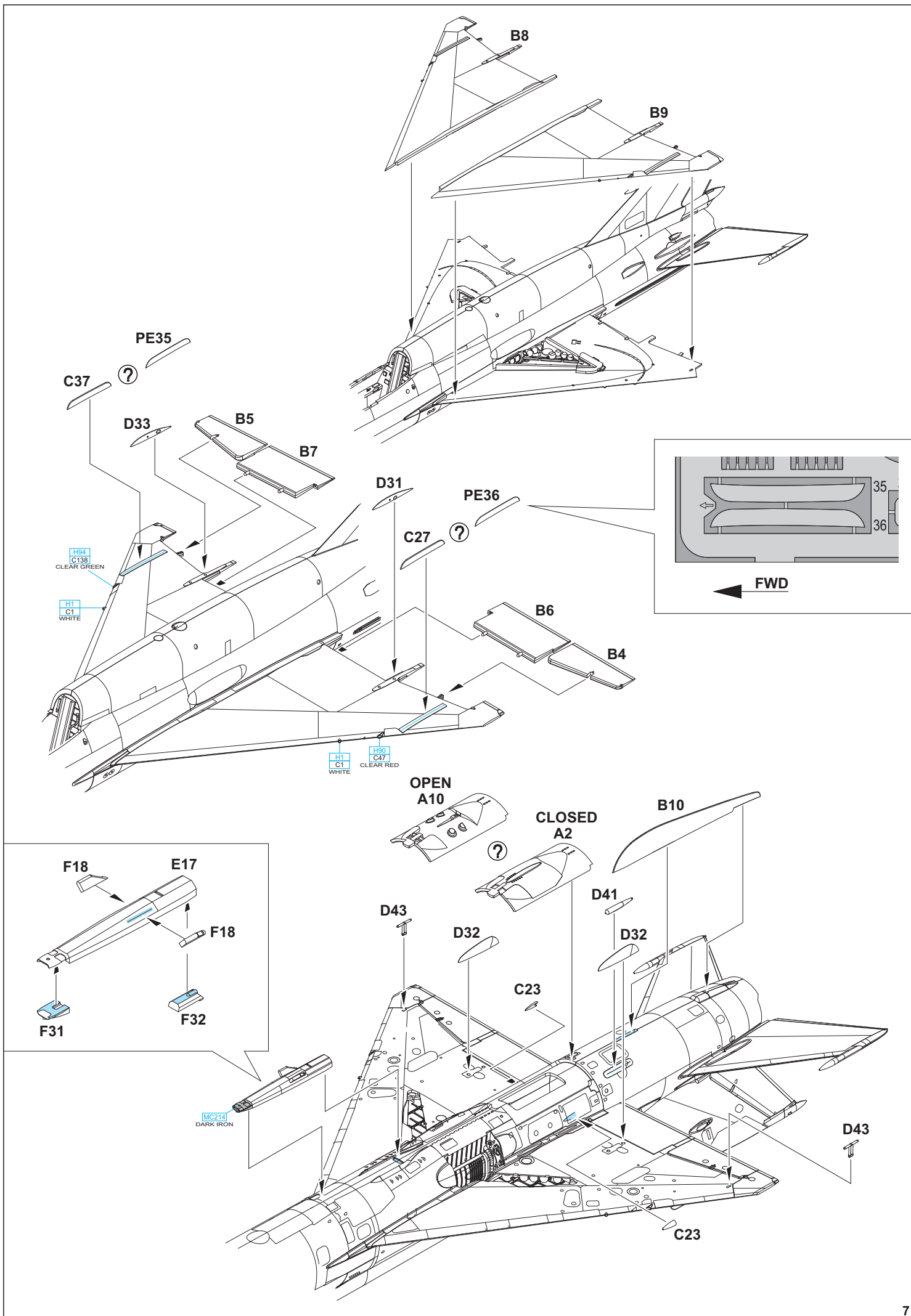

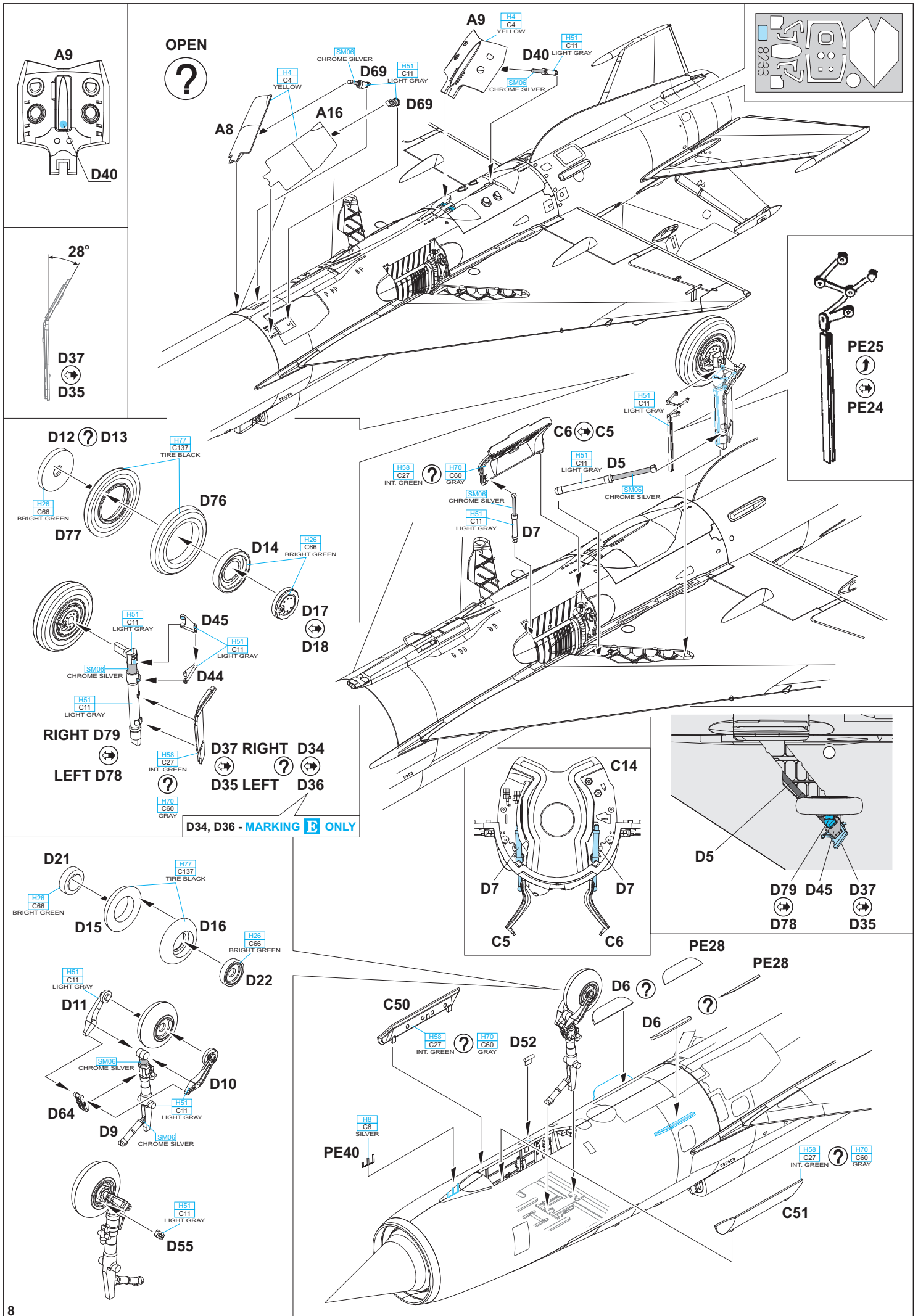

OPEN



A9

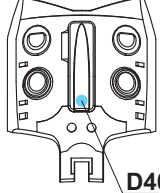

D40

28°



D37  
D35

D12 ? D13

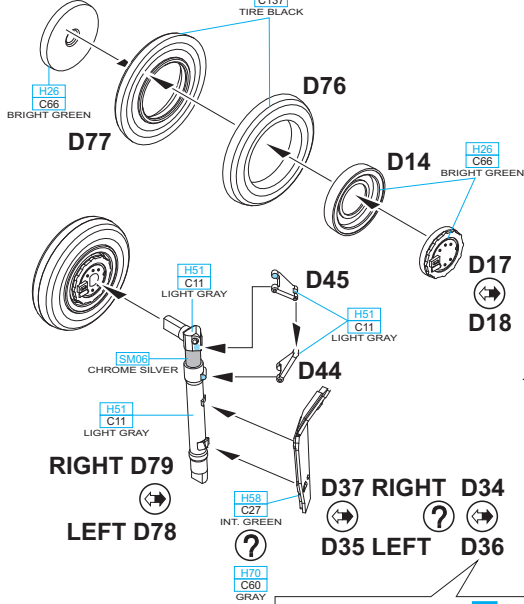

RIGHT D79  
LEFT D78

D37 RIGHT D34  
D35 LEFT D36

D34, D36 - MARKING E ONLY

D21

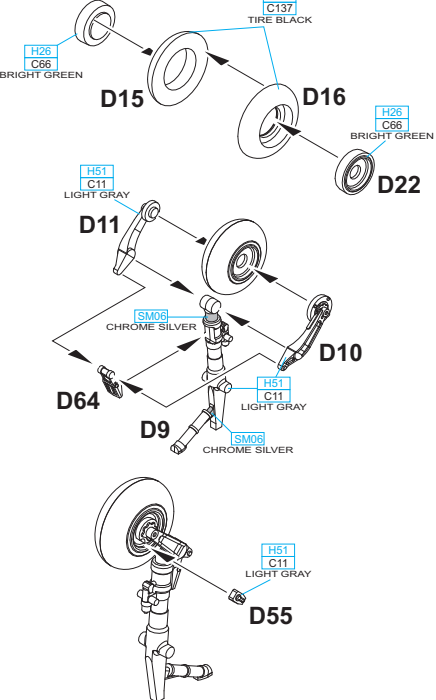

D64

D9

D55

C14

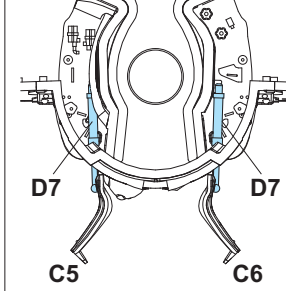

C5

C6

D5

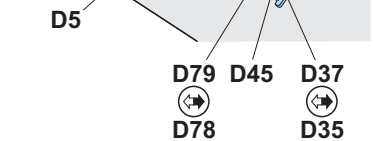

D79 D45 D37  
D78 D35

PE28

PE28

C50

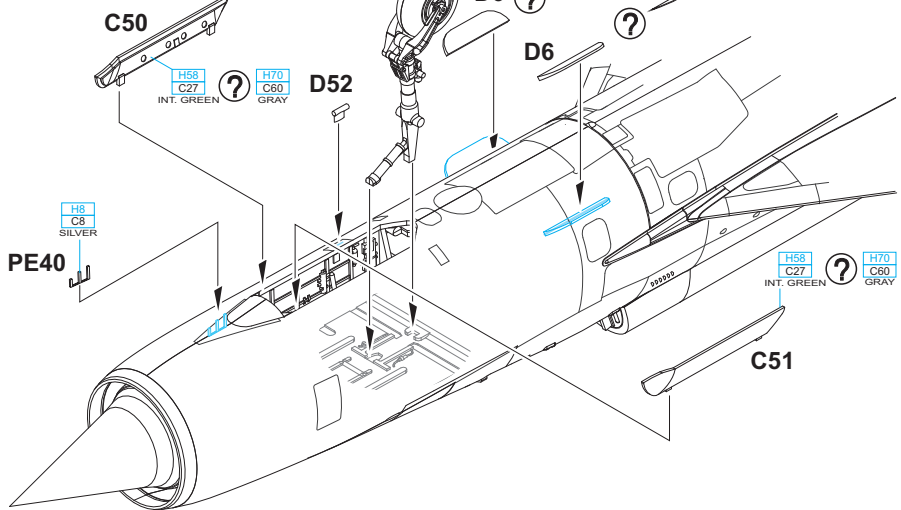

PE40

D52

D6 ?

D6 ?

H58 C27 INT. GREEN ? H70 C60 GRAY

C51



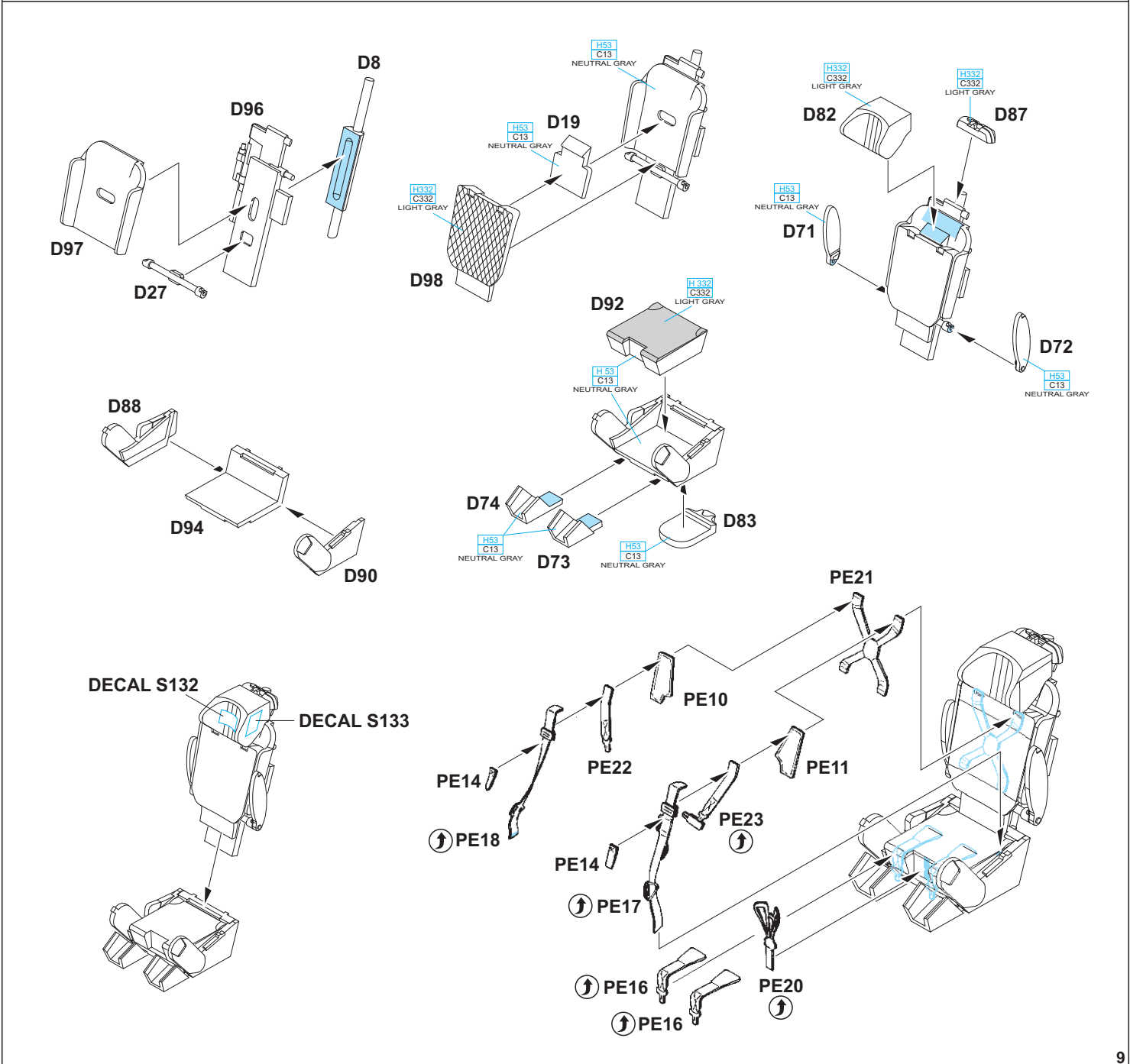
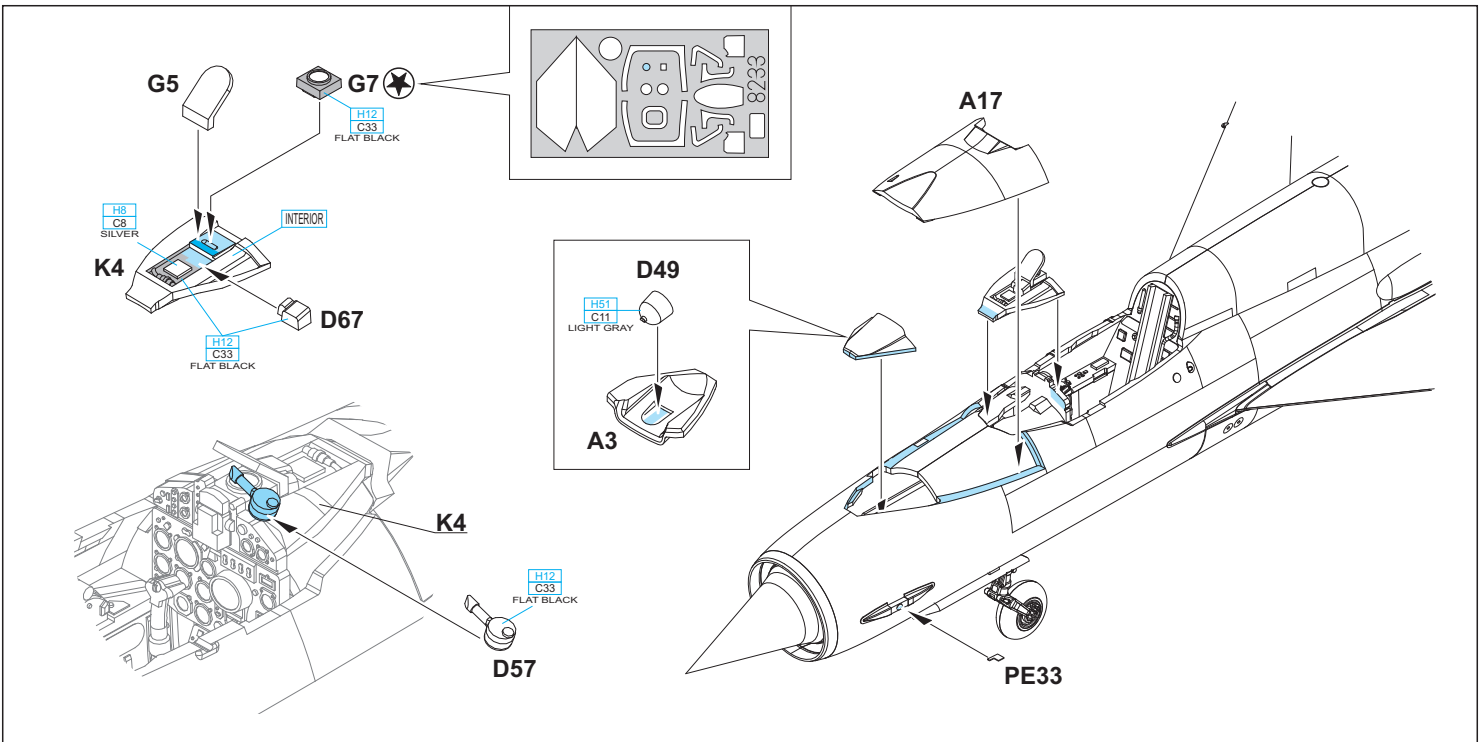

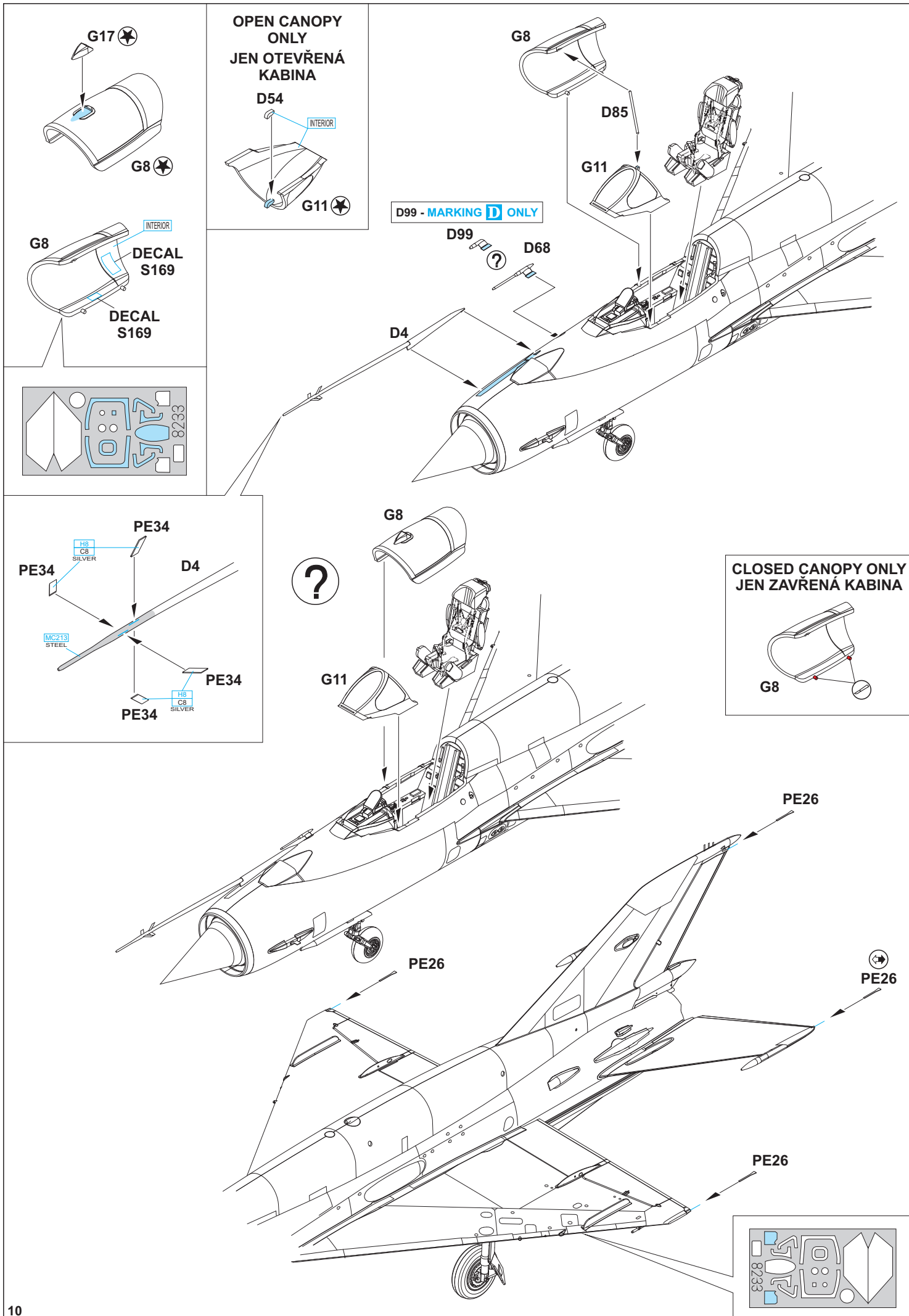

**EXTERNAL FUEL TANK 800I**  
**PRÍDAVNÁ NÁDRŽ 800I**

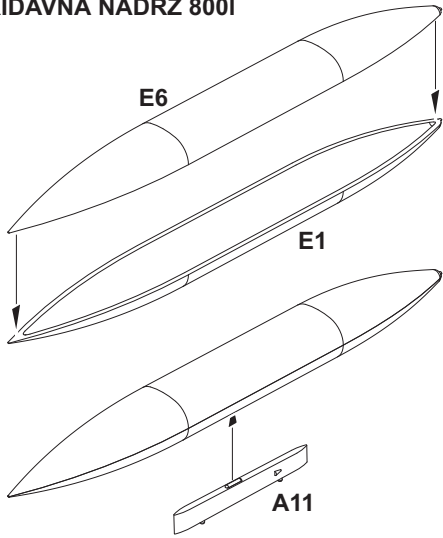

**EXTERNAL FUEL TANK 490I**  
**PRÍDAVNÁ NÁDRŽ 490I**  
 2 pcs.

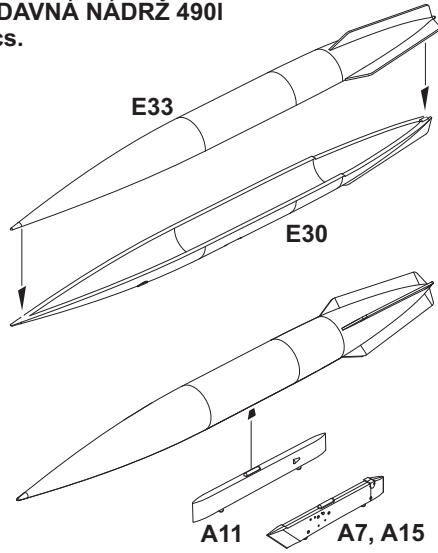

**S-24**  
 2 pcs.

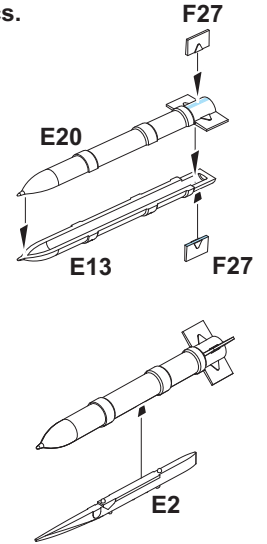

**RS-2US**  
 2 pcs.

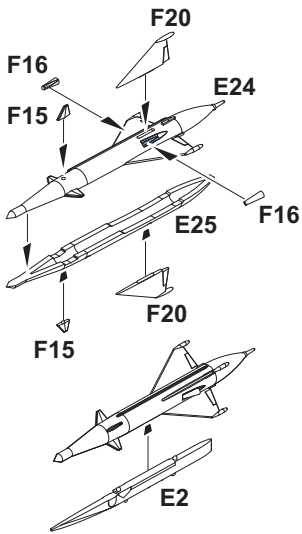

**R-3S**  
 2 pcs.

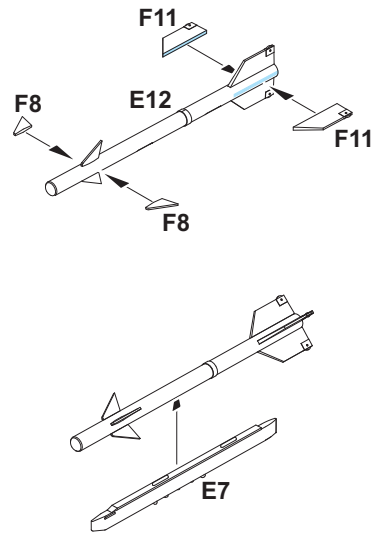

**R-13**  
 2 pcs.

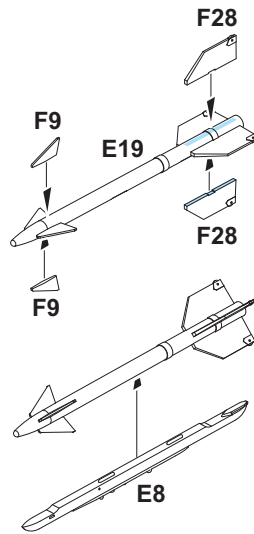

**R-3R**  
 2 pcs.

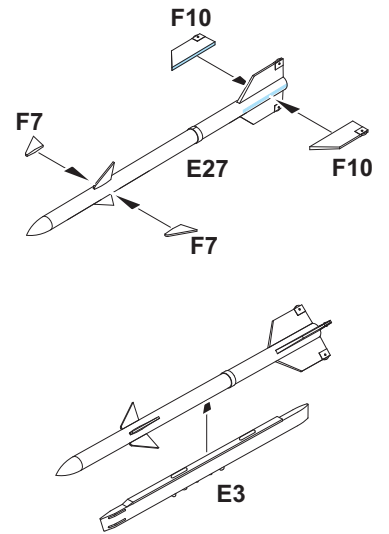

**FAB 100 BOMB**  
 8 pcs.

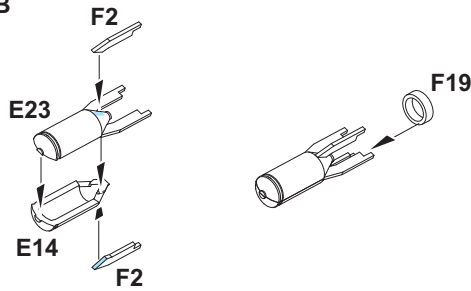

**FAB 250 BOMB**  
 2 pcs.

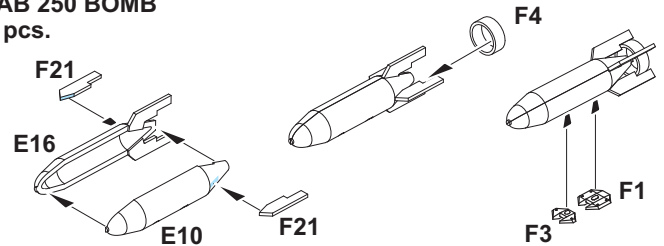

**MBD FOR 4x FAB 100**  
 2 pcs.

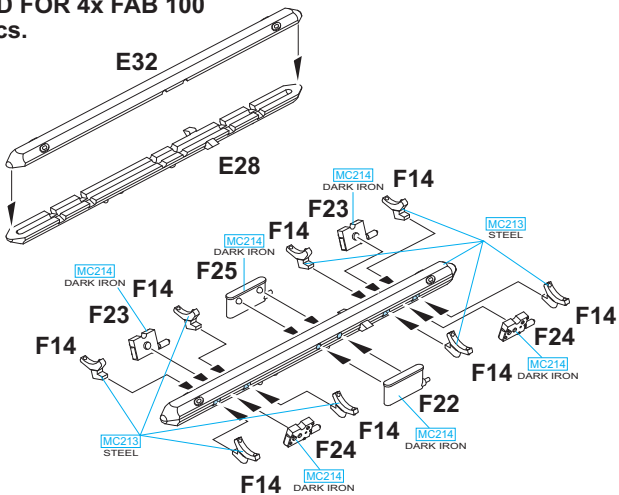

**UB-16**  
 2 pcs. **eduard BRASSIN**

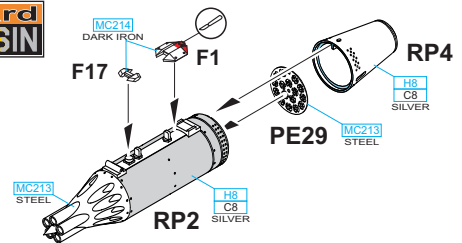

**UB-32**  
 2 pcs. **eduard BRASSIN**

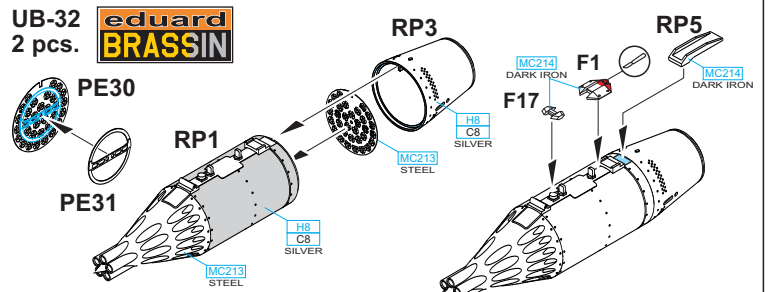

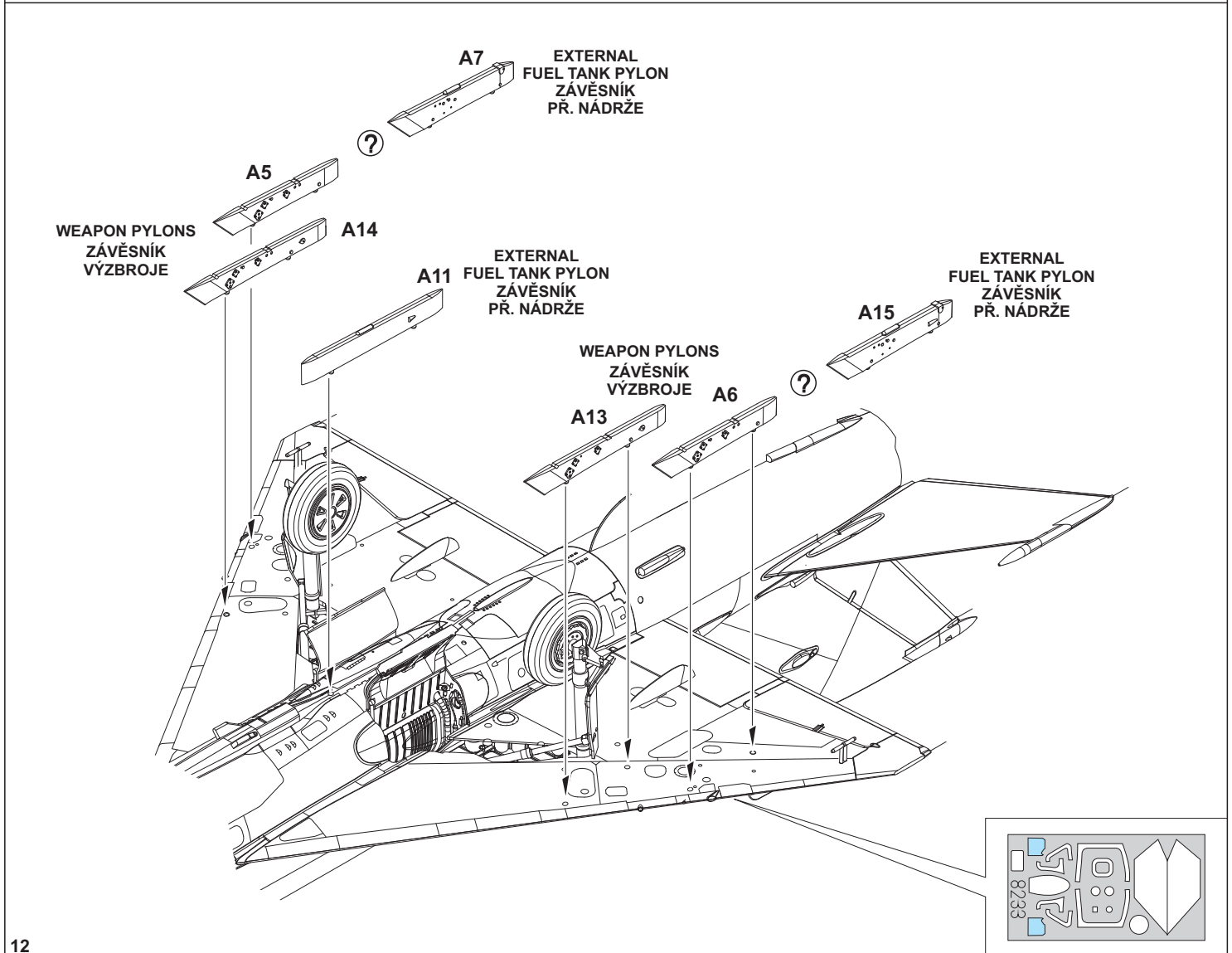
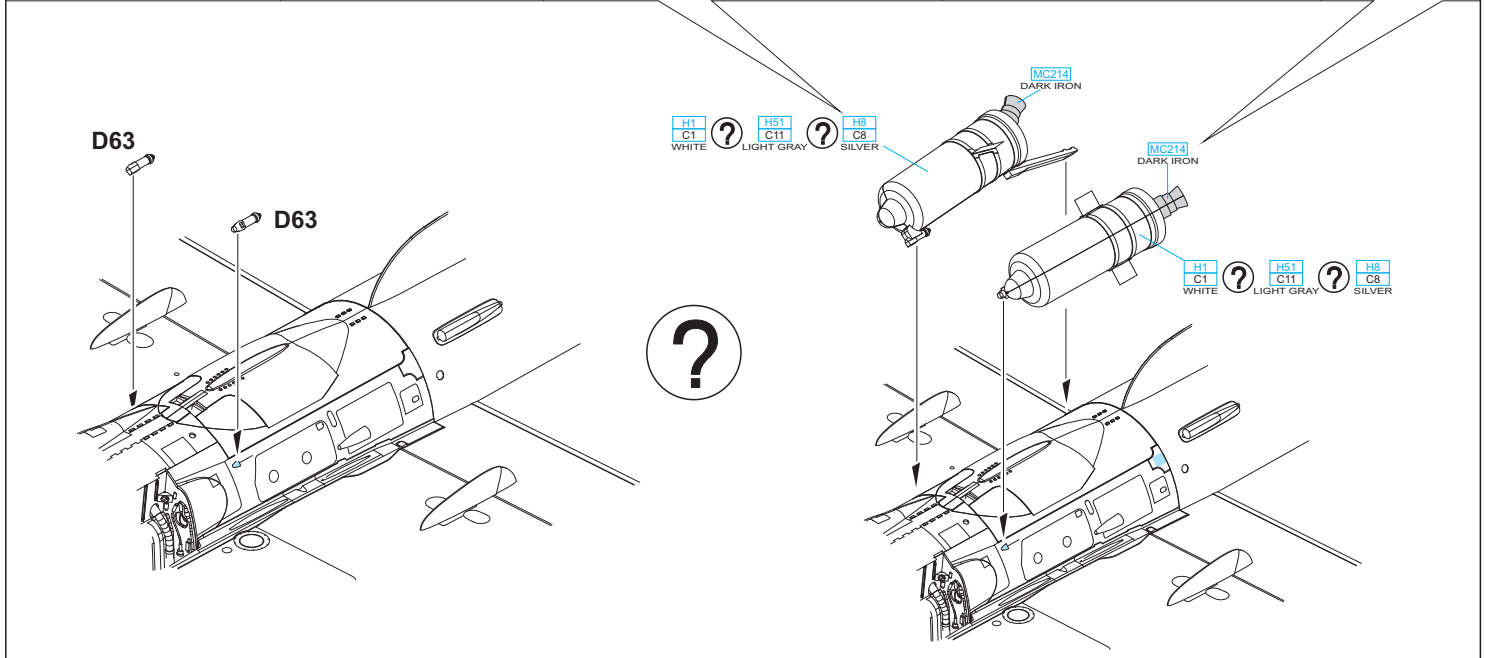
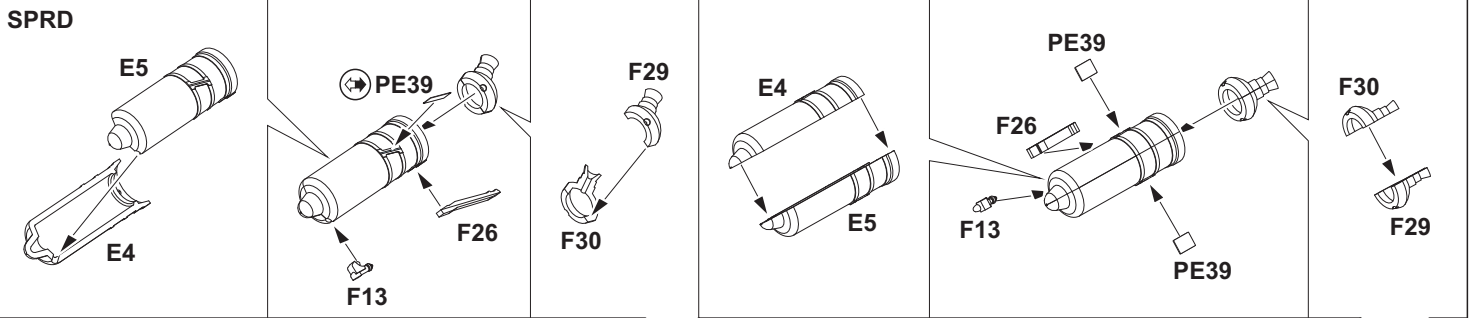

**EXTERNAL FUEL TANK 800I**  
**PŘÍDAVNÁ NÁDRŽ 800I**

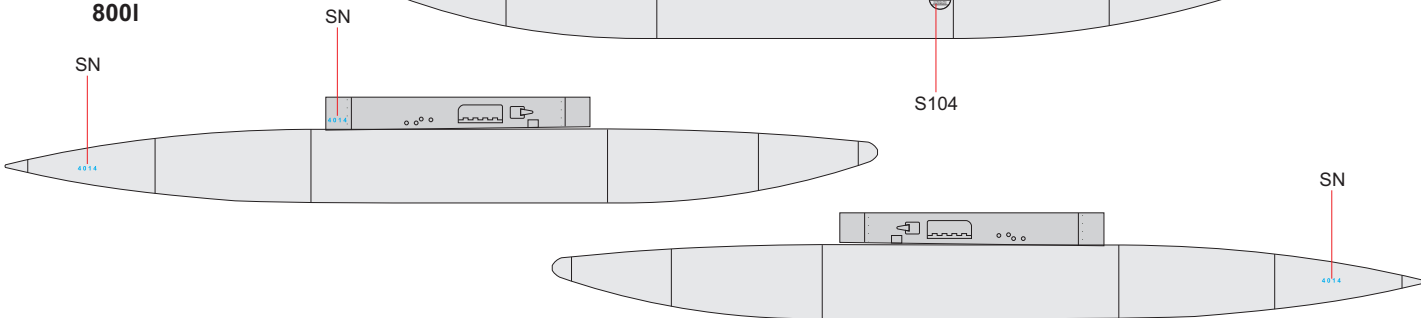

**EXTERNAL FUEL TANK 490I**  
**PŘÍDAVNÁ NÁDRŽ 490I**

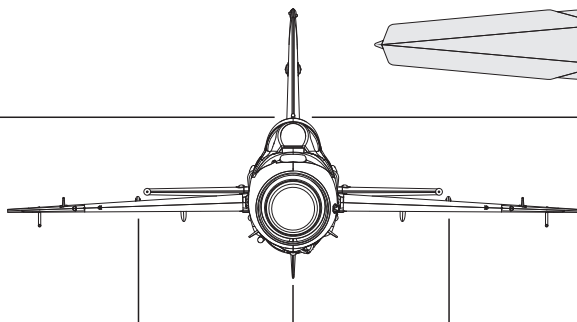
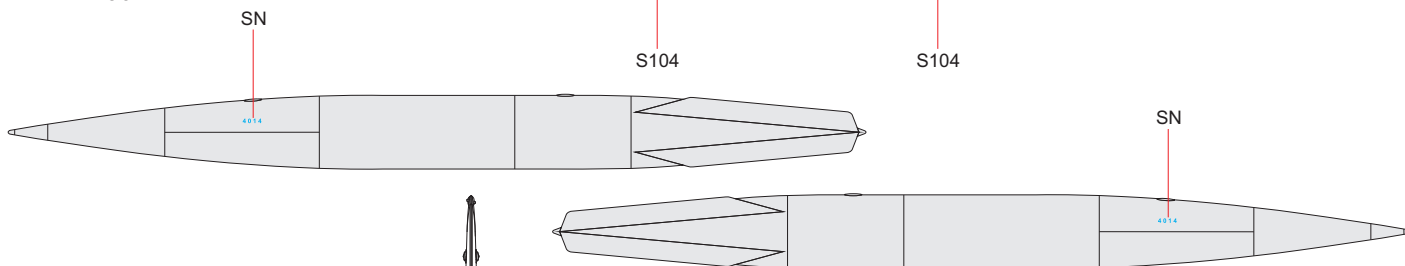

**EXTERNAL FUEL TANK 800I**



**EXTERNAL FUEL TANK 490I**



**EXTERNAL FUEL TANK 490I**

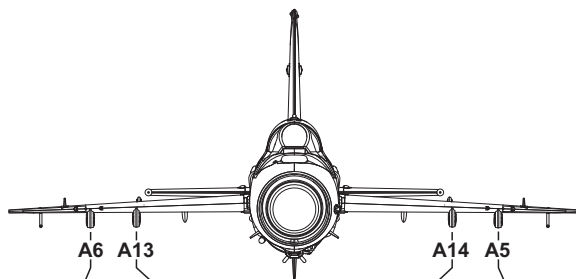

**S-24**

**RS-2US**

**R-3S**

**R-13**

**R-3R**

**MBD**

**FAB 100 BOMB**

**FAB 250 BOMB**

**UB-16**

**UB-32**

**TO CHOOSE WEAPON AND EXTERNAL FUEL TANK OPTION PLEASE FOLLOW YOUR REFERENCE.**

**PRO VOLBU VÝZBROJE A PŘÍDAVNÝCH NÁDRŽÍ SE DRŽTE DOKUMENTACE KONKRÉTNÍHO STROJE.**

LEVÝ  
VNĚJŠÍ PODKŘÍDLOVÝ  
PALIVOVÝ  
LEFT OUTSIDE  
UNDERWING TANK PYLON

**SN - SERIOVÁ ČÍSLA**  
**MALÉ NA DRÁK LETOUNU**  
**STŘEDNÍ NA ZÁVĚSNÍKY**  
**VELKÉ NA RAKETNICE**

**SN - SERIAL NUMBER**  
**SMALL FOR AIRFRAME**  
**MEDIUM FOR PYLONS**  
**LARGE FOR ROCKET LAUNCHERS**

PRAVÝ  
VNĚJŠÍ PALIVOVÝ  
PYLON  
RIGHT OUTSIDE  
UNDERWING TANK PYLON

PODTRUPOVÝ PYLON  
FUSELAGE PYLON

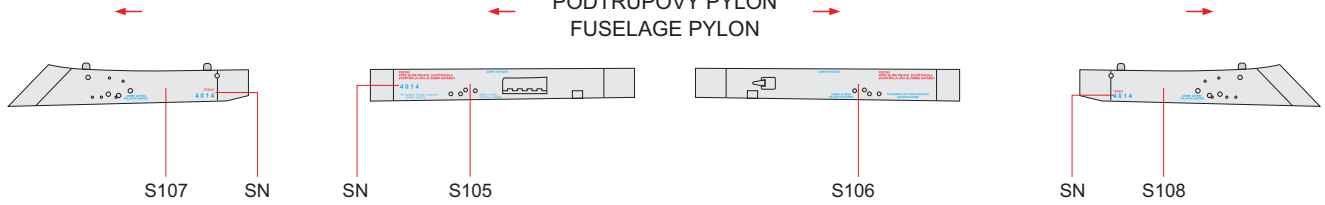

LEVÝ VNĚJŠÍ PYLON  
LEFT OUTSIDE PYLON

PRAVÝ VNĚJŠÍ PYLON  
RIGHT OUTSIDE PYLON

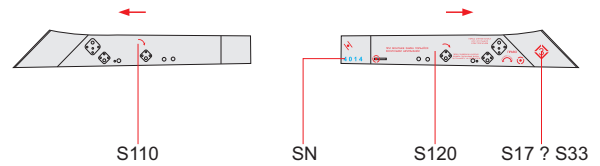
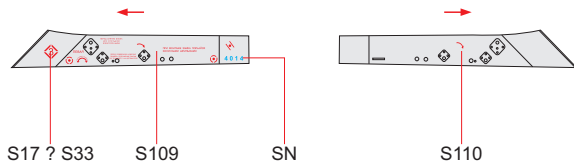

LEVÝ VNITŘNÍ PYLON  
LEFT INSIDE PYLON

PRAVÝ VNITŘNÍ PYLON  
RIGHT INSIDE PYLON

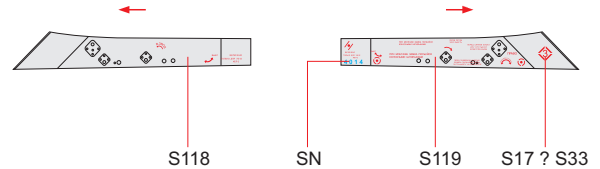
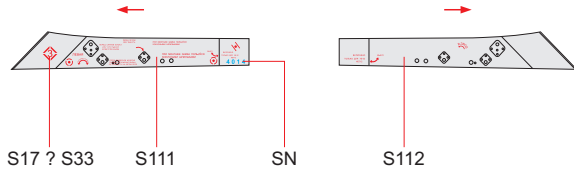

APU-7

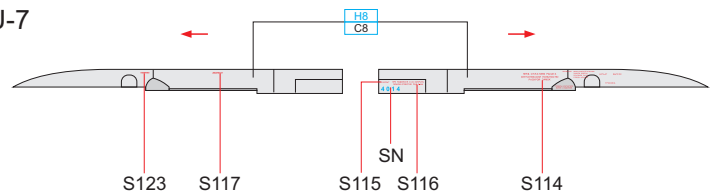
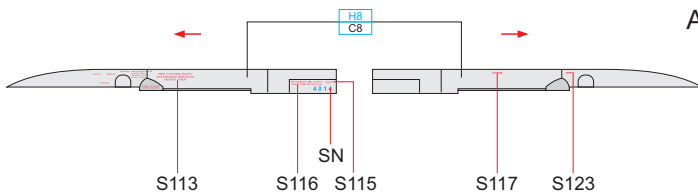

APU-13

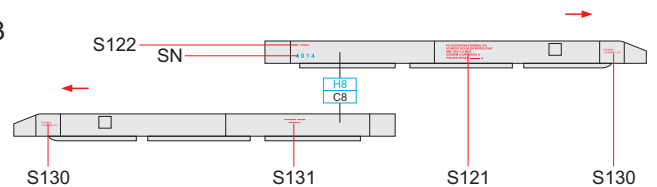
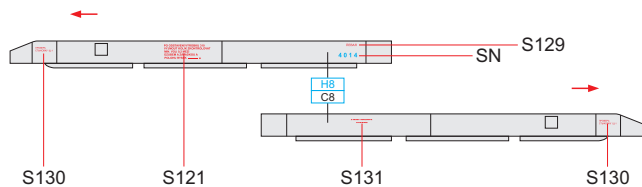

APU-13MT

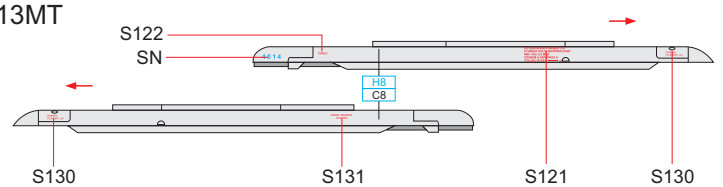
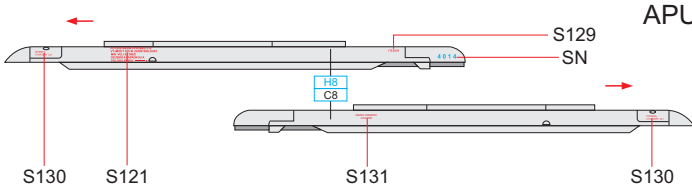

APU-13

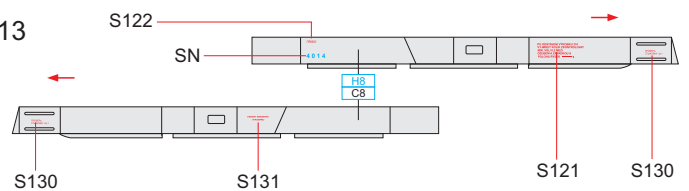
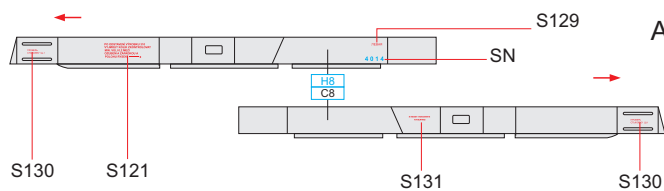

APU FOR R-60

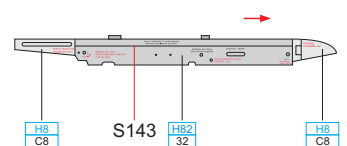
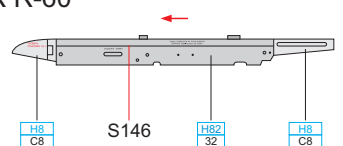
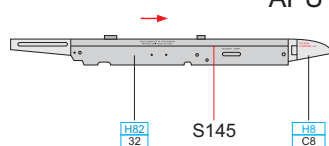
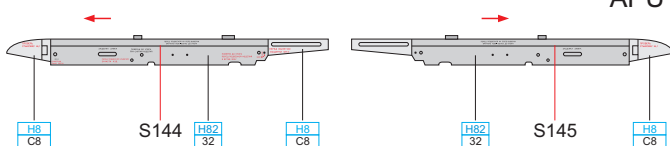

RS-2US

TOP

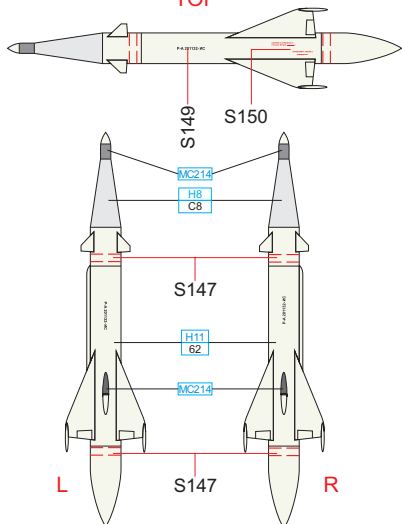

S-24

TOP

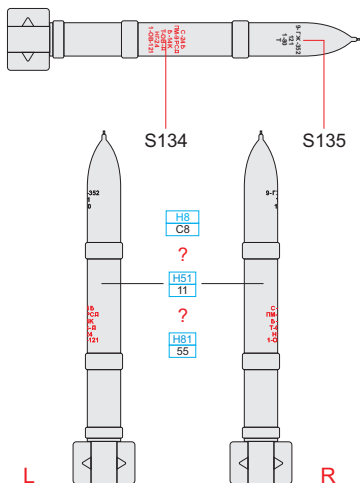

UB-16

TOP

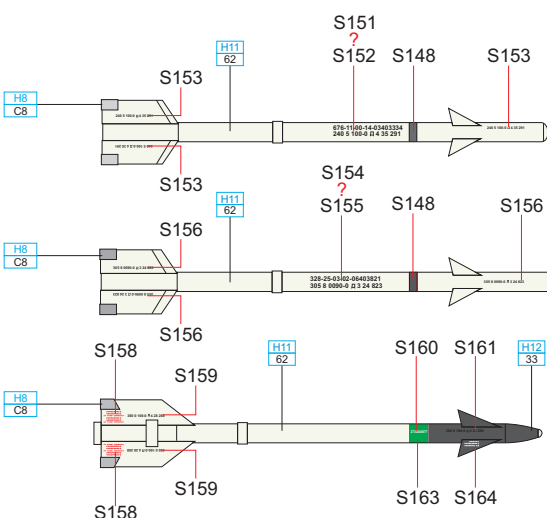
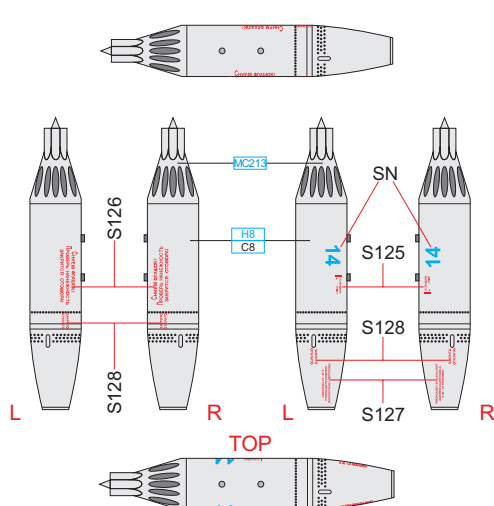

R-3S

R-3R

R-13

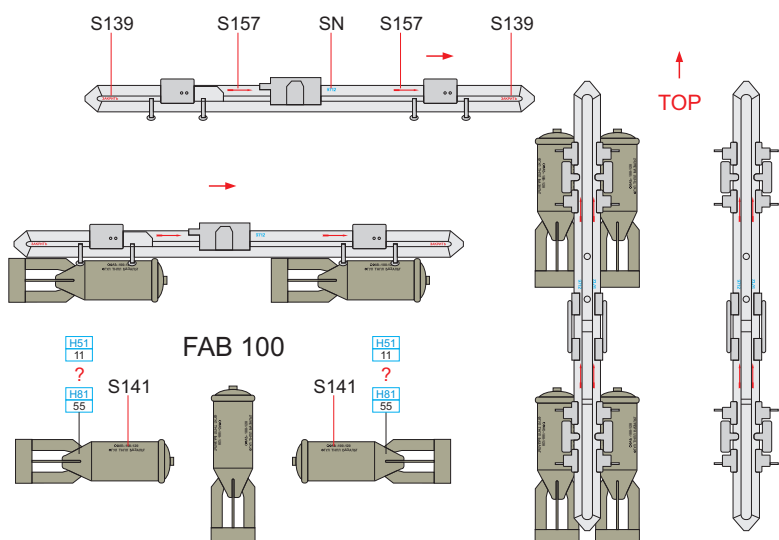
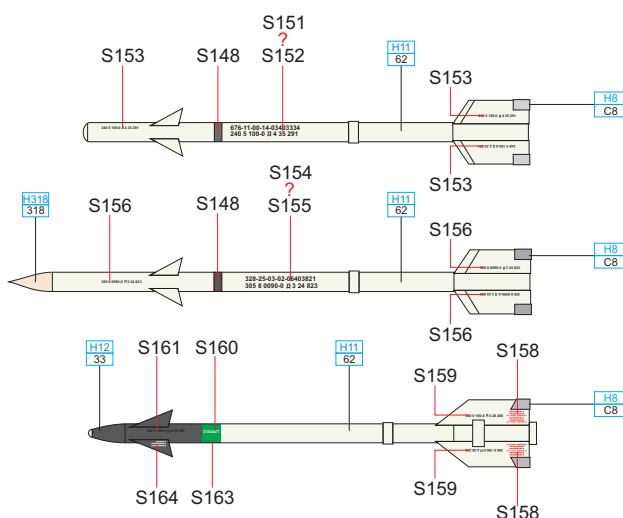

FAB 100

FAB 250

UB-32

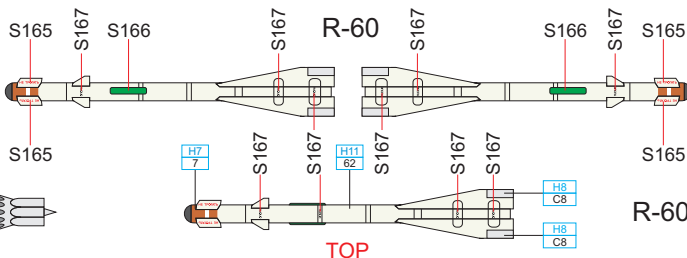
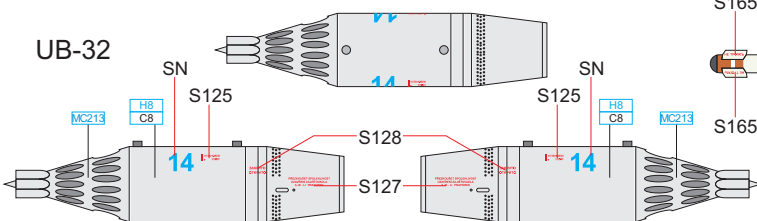

R-60

R-60

# A MiG-21MT, Serial Number 96.40.14, Dolgoye Ledovo, Russia

Aircraft serialled 96.40.14 was one of only fifteen version MTs produced (factory designated 'Izdelye 96B'). The history of this largely unsuccessful version is not all that clear. It would appear that twelve of these flew with 66th APiB (Fighter-Bomber Air Regiment) based at Vescevo, and the remaining three at Kubinka for display to foreign delegates. It is possible that these aircraft also served with the 4th Squ., 234th GIAP (Guards Fighter Air Regiment). Currently, this aircraft can be found at the airfield at Dolgoye Ledovo near Moscow, as a teaching aid and is part of the military department of MEI (Moscow Energy Institute - Technical University).

Letoun výrobního čísla 96.40.14 byl jedním z pouhých 15 vyrobených kusů verze MT (tovární označení - izdělje 96B). Historie této neúspěšné verze jednadvacítky není zcela jasná. Zdá se, že dvanáct kusů používal 66. APiB (stíhací-bombardovací letecký pluk) na letišti Věščevo a tři zbylé létaly v Kubince při předvádění zahraničním delegacím. Je možné, že tyto stroje sloužily u 4. eskadry 234. GIAP (gardový letecký stíhací pluk). V současné době se tento letoun nachází na letišti Dolgoye Ledovo poblíž Moskvy jako učební pomůcka a exponát vojenské katedry MEI (Moskevský energetický institut – technická univerzita).

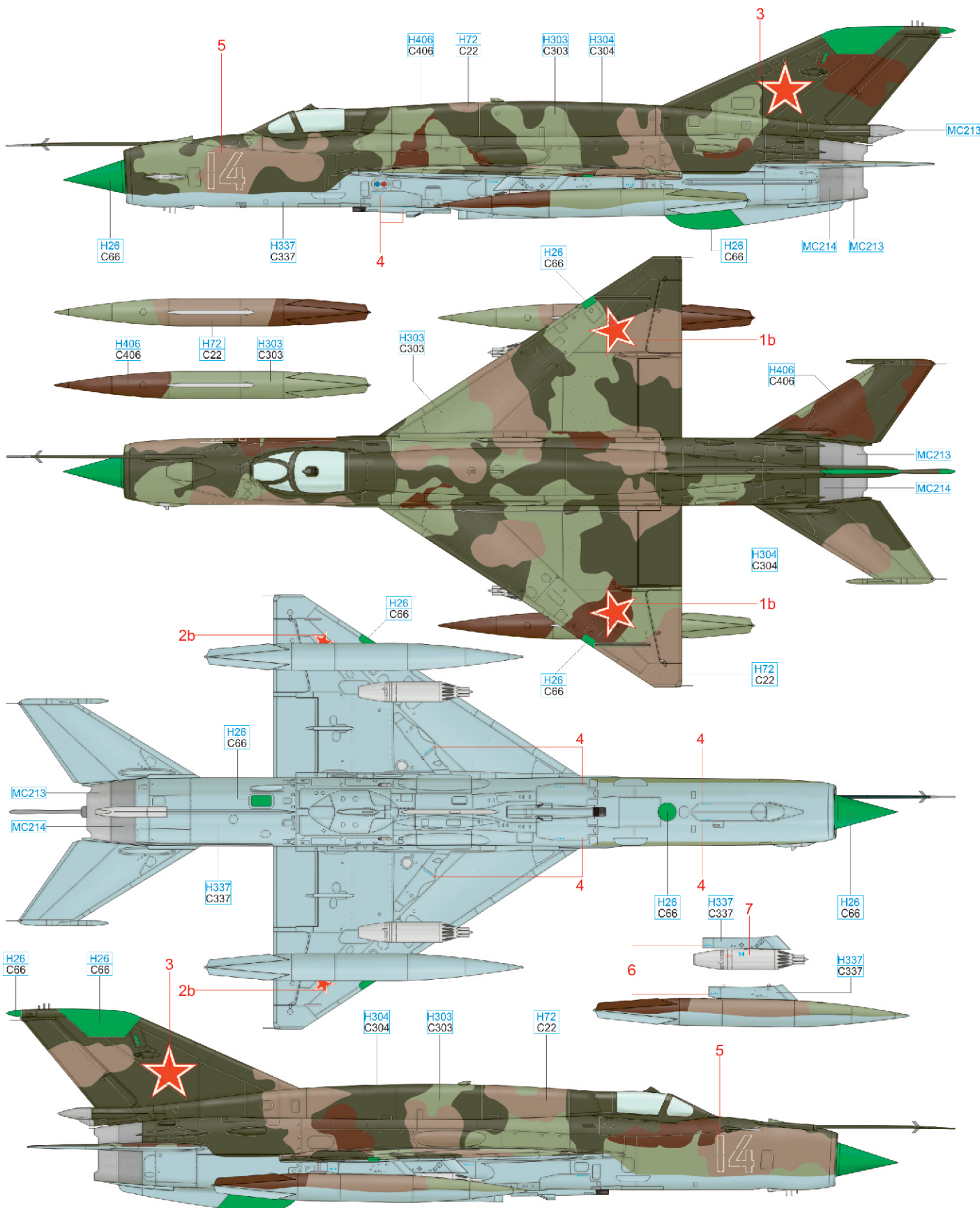

STEEL	MC213												
DARK IRON	MC214	FS 14062	H26 C66	FS 24277	H337 C337	FS 34102	H303 C303	FS 34087	H304 C304	DARK EARTH	H72 C22	CHOCOLATE BROWN	H406 C406



# B MiG-21MT, Serial Number 96.40.15, Dolgoye Ledovo, Russia

This aircraft can also be currently found at Dolgoye Ledovo, along with White '14', and, among others MiG-21MT 'Blue 11'. It is interesting to note that all three MTs carry different camouflage schemes. The MT was built by the Moscow plant Znamya Truda in 1971. It was derived from the fighter-bomber SMT version, which was a response to the request for greater range by installing the R-13F-300 engine and a greater internal fuel load. The 600 litres of fuel were located in the spine, giving this version its characteristic hunch back appearance. This had the impact by worsening the aircraft's flight characteristics. Although the MT was intended to be an export version, no clients were ever found.

Také stroj výrobního čísla 96.40.15 se nyní nachází v Dolgém Ledovo. Společnost mu kromě „bílé 14“ a dalších strojů dělá ještě MiG-21MT „modrá 11“. Je zajímavé, že každý ze třech vystavovaných MT nese jinou kamufláž.

Verzi MT vyrobila moskevská továrna Znamya truda v roce 1971. Vycházela ze stíhací-bombardovací verze SMT, která reagovala na požadavek zvětšení doletu tím, že dostala motor R-13F-300 a větší množství neseného paliva. Rozměrnější, o 600 litrů objemnější palivová nádrž našla své místo ve hřbetu trupu a dala tak této verzi charakteristický „hrb“. Zásahy do konstrukce se však projeví zhoršenými letovými vlastnostmi.

Ačkoliv byla MT zamýšlena jako exportní verze, nikdy ji žádný zahraniční uživatel nekoupil.

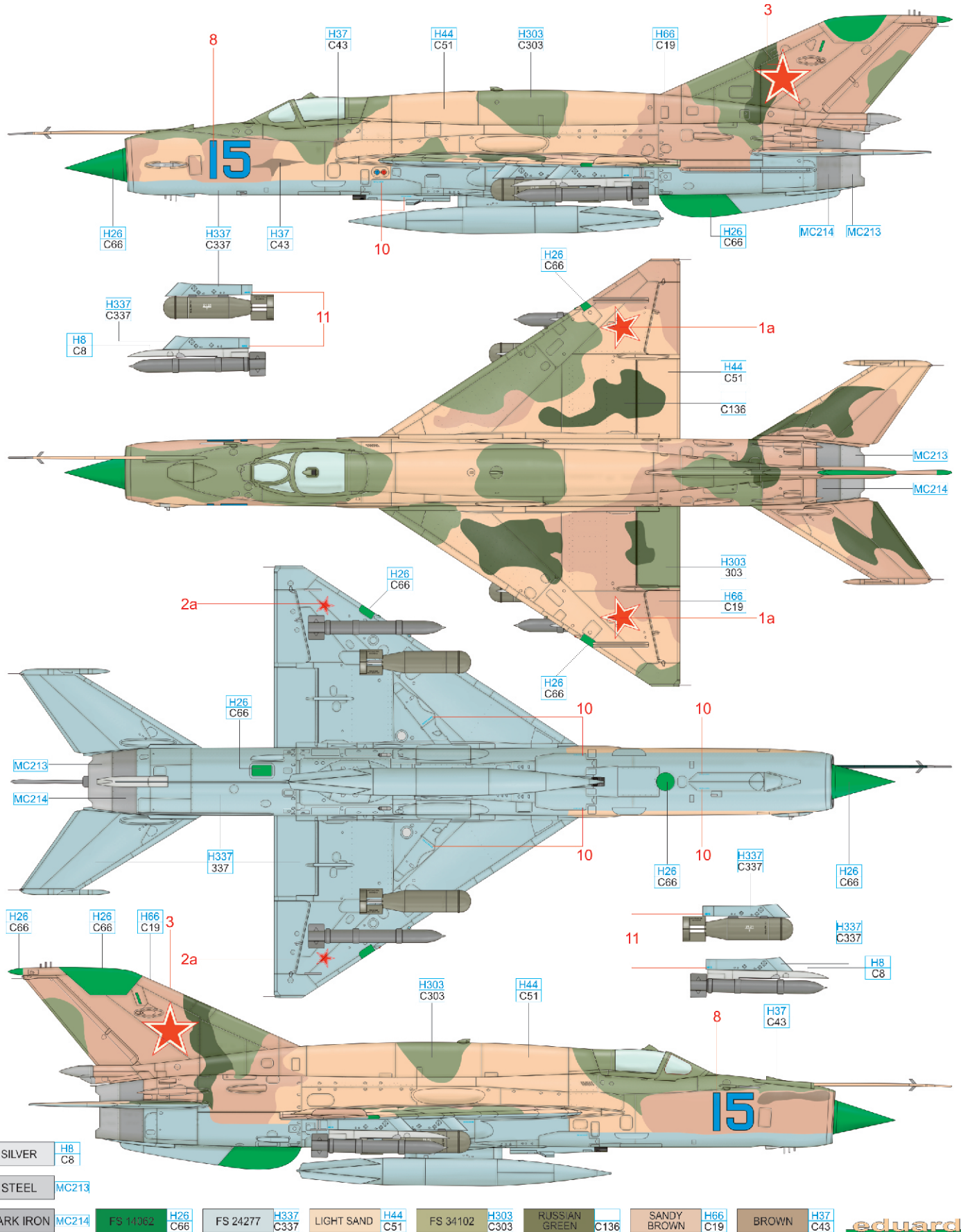

# C MiG-21SMT, 582<sup>nd</sup> IAP, Chojna Airfield, Poland, Late Eighties

This aircraft, serialised 500.23.098 can currently be found in the private collection of Svedinos Car and Aircraft Museum in Sweden. This aircraft got to the museum via the town of Landskrona, where it served as a prop in front of an army surplus store. Given the color and appearance of the fuselage number, it is assumed that this aircraft served with the 582th IAP (Fighter Air Regiment), which was based at Chojna, Poland (located south of Szczecin and known in the Second World War as Königsberg). This unit used its SMTs between 1972 and 1989. NATO assigned the MT and SMT versions the reporting name Fishbed 'K'.

Stroj výrobního čísla 500.23.098 se nyní nachází ve Švédsku, v soukromém muzeu Svedinos Car and Aircraft Museum. Toto muzeum jej získalo z města Landskrona, kde stál před obchodem s vojenským materiálem. Z tvaru a barevného provedení trupového čísla se usuzuje, že stroj zřejmě původně sloužil u 582.IAP (stíhací letecký pluk), který působil v polské Chojně (letecká základna ležící jižně od Štětína, známá za 2. sv. války pod názvem Königsberg). Stroje verze SMT pluk používal od roku 1972 do 1989. Síly NATO zařadily verze MT / SMT do rozpoznávacích tabulek pod kódovým označením Fishbed K.

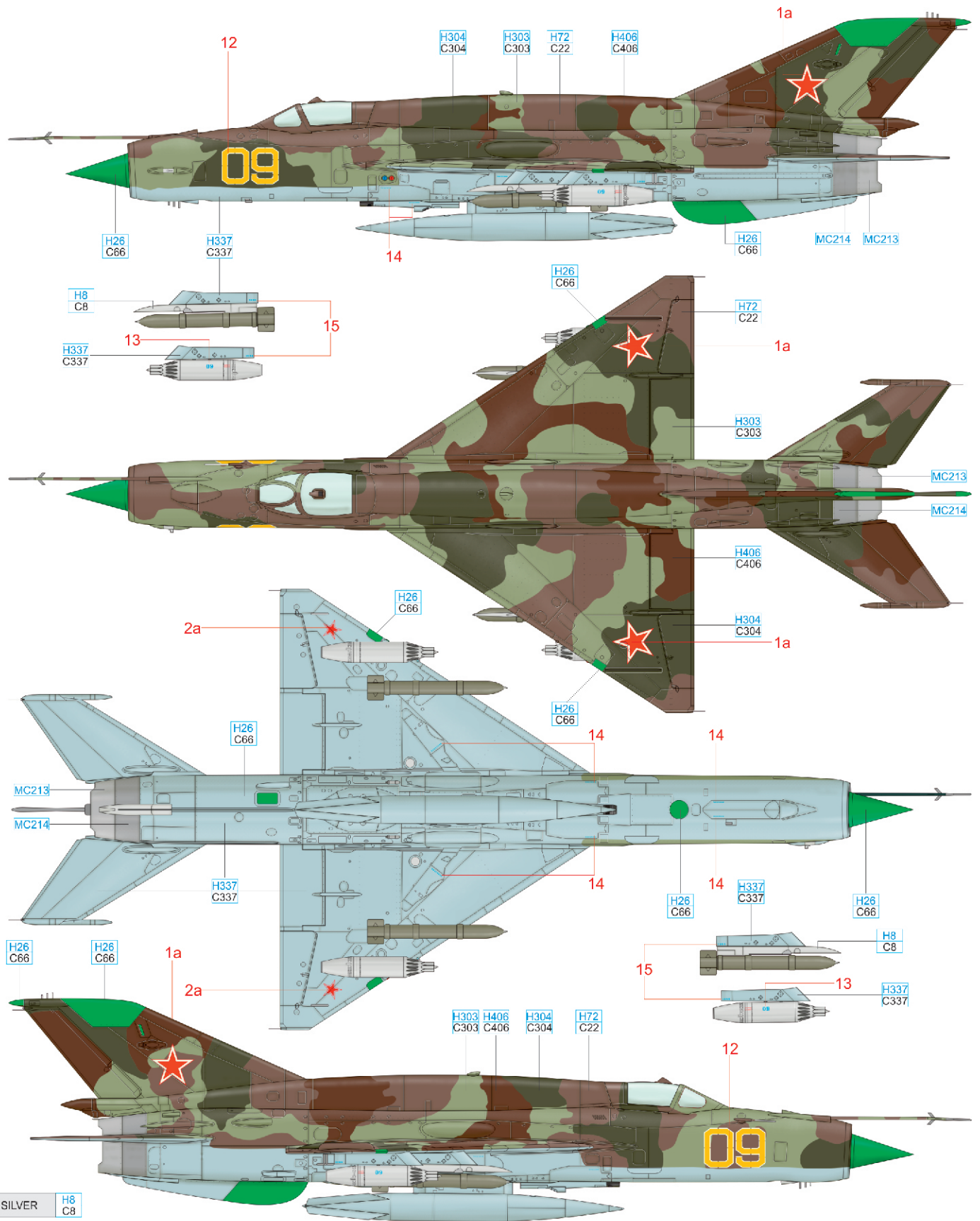

SILVER H8 C8

STEEL MC213

DARK IRON MC214

FS 14032 H26 C66

FS 24277 H337 C337

FS 34102 H303 C303

FS 34087 H304 C304

DARK EARTH H72 C22

CHOCOLATE BROWN H406 C406

eduard

# D MiG-21SMT, Krasnodar Higher Aviation Training Facility, Soviet Union, ca 1980

This aircraft served at the end of the seventies through the beginning of the eighties at the noted training facility, that trained foreign pilots to fly Soviet types. MiG-21 familiarization was undertaken here by pilots from Viet Nam, Angola, Cuba, and other countries who could be called Soviet client states. The marking under the cockpit is that of the Komsomol (Communist Youth League - preparation for the communist party), which it would have gained in honor of successful competition of airman-mechanic teams in socialist competition on the occasion of a meet within this communist organization.

Tento letoun sloužil na přelomu 70. a 80. let minulého století v Krasnodarském leteckém učilišti, kde se připravovali na létání se sovětskými letouny zahraniční letci. S MiGy-21 se zde seznamovali například frekventanti z Vietnamu, Angoly, Kuby a dalších států, jejichž tehdejší režimy úzce spolupracovaly se Sovětským svazem. U této školní jednotky se zřejmě ocitl po stažení od prvoliniového útvaru.

Pod kabinou nese znak Komsomolu (bolševická mládežnická organizace – příprava komunistické strany), který se zde ocitl na počest výhry týmu letec – mechanik v socialistické soutěži při příležitosti sjezdu této komunistické organizace.

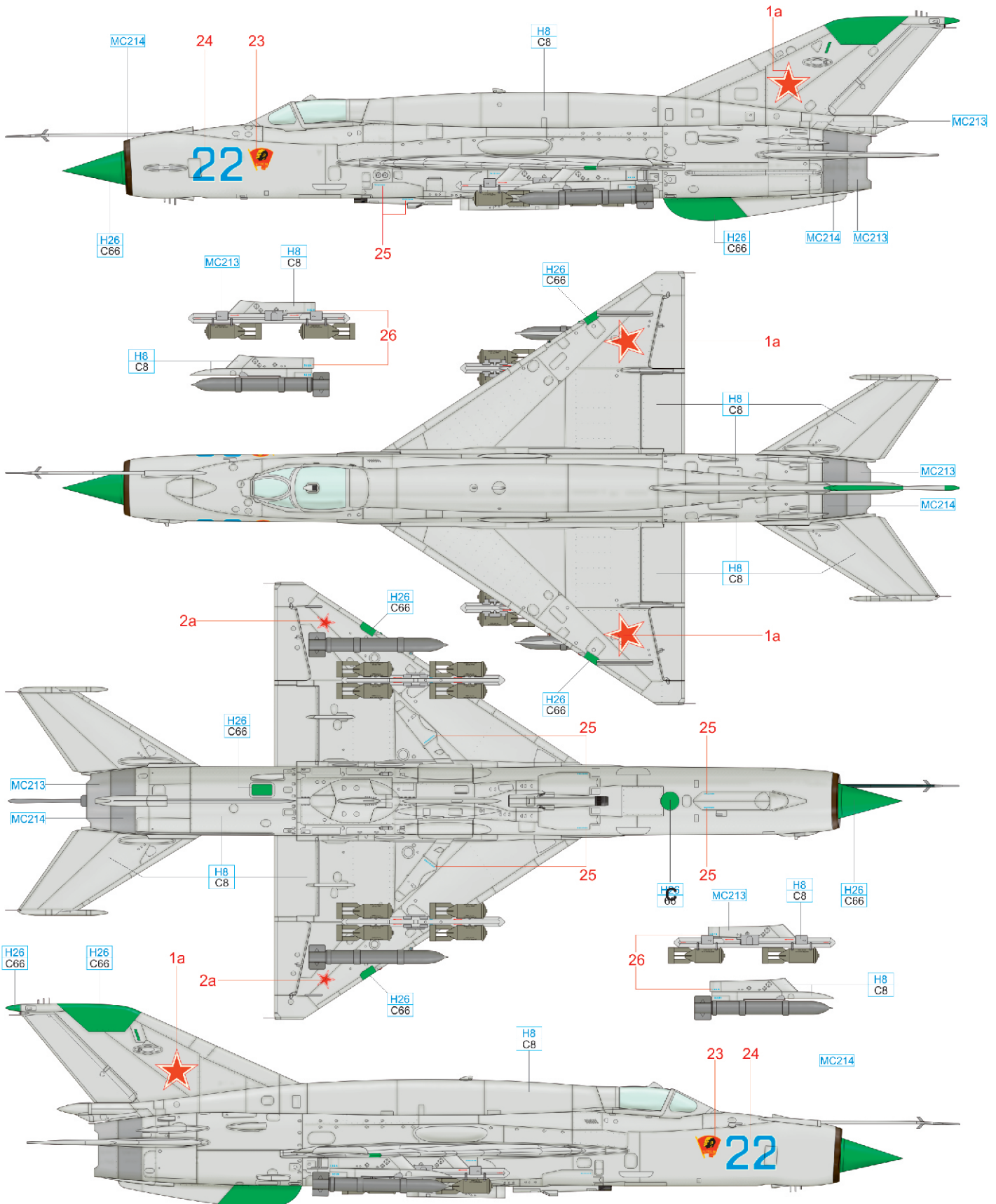

# E MiG-21SMT, 296<sup>th</sup> IAP, Soviet Union

The SMT was the equivalent of the MT intended for home units. In all likelihood, this aircraft hails from the 296th IAP, going by the appearance of the fuselage number. Despite the degraded performance of the SMT, Gorky built a total of 281 units between 1971 and 1973. Some of the SMTs had their enlarged spine reduced in size to that of the MiG-21bis. These aircraft then received the designation MiG-21ST.

Verze SMT byla ekvivalentem exportní verze MT, ovšem určená pro vlastní ozbrojené síly. Tento stroj pochází s největší pravděpodobností od 296. IAP, čemuž nasvědčuje podoba trupového čísla.

Přestože stroje SMT charakterizovaly zhoršené letové vlastnosti, továrna v Gorkém vyrobil v letech 1971 až 1973 celkem 281 kusů. Zvětšený hřbet trupu byl následně u řady letounů přepracován do podoby, kterou nese verze bis. Takto upravené stroje pak nesly označení MiG-21 ST.

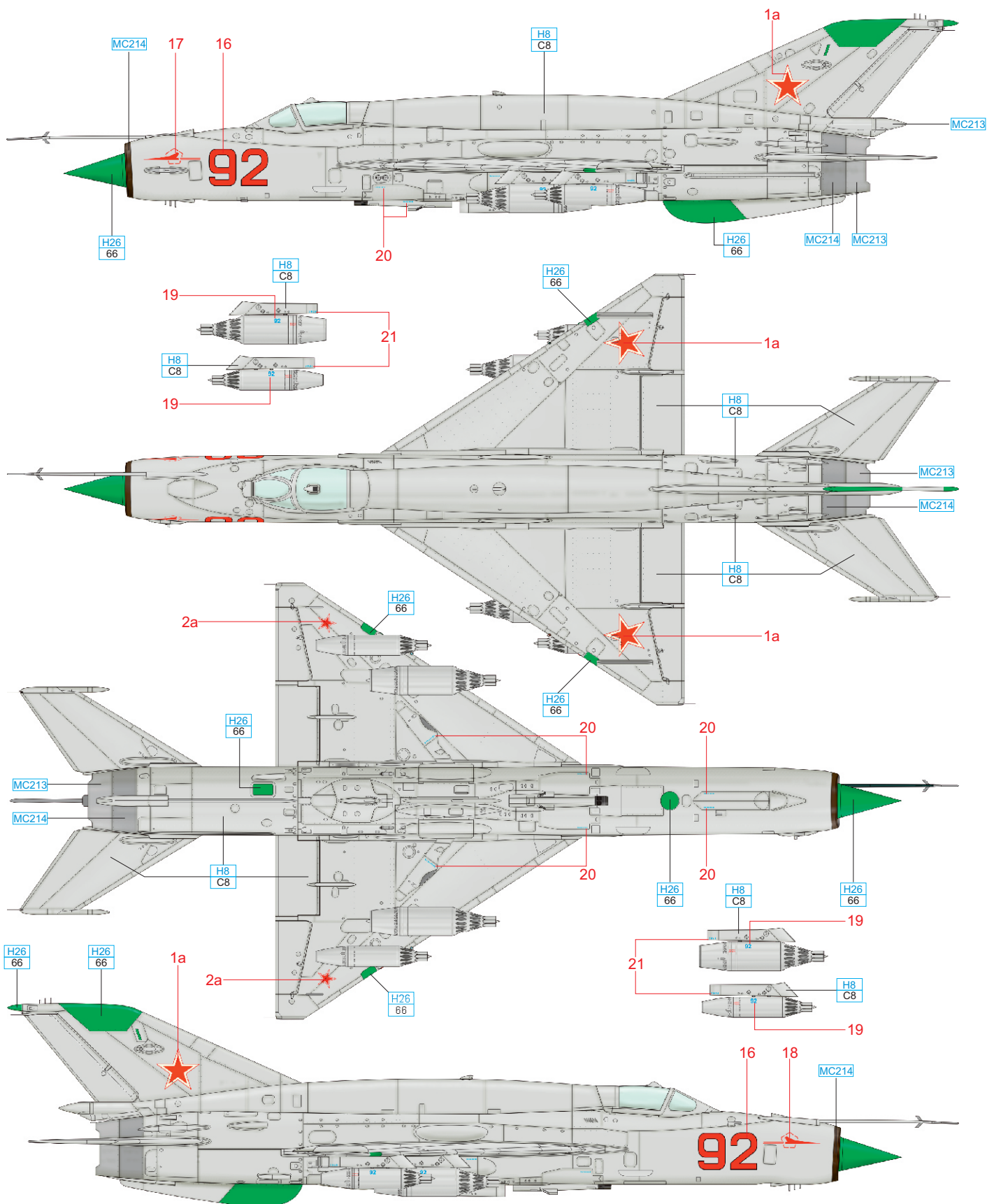

Pro letouny kamuflované jsou určeny popisky červené a modré, pro letouny v barvě kovu nebo šedé použijte popisky červené a černé.  
 Camouflaged aircraft - red and blue stencils. Natural metal and grey aircraft - red and black stencils.

