

# Spitfire Mk.IXc late version

eduard

1/48 Scale Plastic Model Kit

**ProfiPACK**  
edition



item No. 8281

The Supermarine Spitfire is so iconic, that virtually everyone can recognize it. The service of this elegant fighter spanned remarkable 13 years. It entered into service at the end of biplane era and remained on frontline duty until the jet age.

By the early 30s the RAF was looking for replacement of its ageing Hawker Fury biplane fighters. The need of considerably faster aircraft was obvious, as the racing monoplane floatplanes of that time reached about twice the speed of the Fury. One of the most successful designers of the racing floatplanes was Reginald J. Mitchell. His Supermarine S.6B raised the world speed record to 407 mph (655 km/h) on 20 September 1931 and British Air Ministry, under influence of such achievement, issued the specification F.7/30 in October 1931. Although it called for modern pursuit airplane capable of at least 250 mph (400 km/h), seven out of eight entries were biplanes. The only monoplane proposal was Mitchell's Supermarine 224, but the design with a gull wing, fixed undercarriage and Rolls-Royce Goshawk engine was a disappointment because of the lack of speed and poor rate of climb. After that the RAF chose the Gloster Gladiator biplane as the winner.

## Early work

The fiasco with Type 224 did not prevent Mitchell from further work. He persuaded the Supermarine company to fund the work on completely new design Type 300 using brand new Rolls-Royce PV12 engine, later known as the Merlin. The Air Ministry expressed interest and issued specification F.37/34 on December 28, 1934, to fund the prototype armed with four wing mounted guns. But by early April 1935 Mitchell received the detail of specification F10/35, calling for eight guns. The change was made on cost of bomb provision removal and reduction of the capacity of the fuel tanks to sixty-six gallons. The decision caused the so called "short legs" of the Spitfire, meaning a lack of range and endurance.

The Supermarine Type 300 made its maiden flight on March 5, 1936, initial contract for 310 Spitfires was signed in June 1936 and the first unit to receive the new fighter was No. 19 Sqn. at Duxford in August 1938.

## Catching the progress

The development of Spitfire was ongoing process from very early stage of its service and incorporated many changes. From the early Mk. I and Mk. II the development was reaching the point, where a more substantial step was required. The Mk.V was a result, but it was in fact a Mk.I powered by the more powerful Merlin 45 series engine. The Mk.V entered the service from early 1941, helping the RAF to countermeasure development of the Bf 109. But in September 1941, a hitherto unknown German radial engine fighter emerged and started to rule the European skies. The new Fw 190 was superior to British fighters, most distressingly to the Spitfire Mk.V. The losses suffered by the RAF over western Europe rose rapidly and the crisis was serious enough that the RAF ceased most daytime operations during November 1941. The next attempt to resume this type of sorties was made in March 1942. But losses remained unacceptably high, and the RAF was forced to stop offensive operations once again. All this was due to the supremacy of the Focke-Wulf Fw 190A.

The first RAF response to the new situation was the Spitfire Mk.VIII, but the design changes were so complex that initiating timely production was not possible. In June 1942, a German pilot landed on a British airfield by mistake delivering a completely intact Fw 190A fighter into RAF hands. Comparative trials between the Focke-Wulf and Spitfire Mk.V began almost immediately and verified the situation over the front – the chance of a Spitfire Mk.V to survive an encounter with the Fw 190s was rather poor. The only British fighter aircraft deemed suitable to oppose the German fighter were the Spitfires Mk.VII and Mk.VIII powered by the Merlin 61 engine. These marks required some time to get into production, so another way of getting a powerful fighter as quickly as possible was sought. And it was found in mating the two –stage supercharger Merlin 61 with the fuselage of the Spitfire Mk.Vc.

## The Saviour

Flight trials of two modified Mk.Vs were successful and the order for series production was issued immediately. Series production began in June 1942 and the first Mk.IXs found their way to No. 64 Squadron in July. Performance improved significantly in comparison to the Mk.V. The top speed of 409 mph (658 km/h) at 28,000 feet (8530 m) was higher by 40 mph (64 km/h), and the service ceiling rose from 36,200 ft (11,033 m) to 43,000 ft (13,106 m). The Mk.IX began to replace the Mk.V from June 1942. Thanks to the new fighter, the RAF was ready to fight against the Luftwaffe over occupied Europe.

Three main variants of the Mk.IX were produced. The F Mk.IX was powered by the Merlin 61 and was the only version on the assembly line in early 1943. The next was the LF Mk.IX powered by the Merlin 66. This engine was designed to do its best at low-to-medium altitude. The third version, manufactured along with the LF, was the high-altitude HF Mk.IX with the Merlin 70.

The majority of Mk.IXs was equipped with the so-called C-type wing. Four 20mm cannons or two 20mm cannons and four .303 in machine guns could be installed in the wings. From 1944, the strengthened E-type wing was produced. Four outer .303 machine guns were replaced with two .50 in heavy machine guns installed in the inner bays. Bomb racks for 250lb bombs were fitted under each wing.

## The Kit: Mk.IXc late production

The Mk.IXc design developed during the production in several areas. As the "universal" C-type wing was intended to accommodate up to four 20mm cannons, the large blisters allowing such as installation were retained. But the four cannons armament proved quite heavy for Spitfire, so the blisters were narrowed in late series, as the two cannons were mounted in the inner position of the double cannon bays. The Merlin 61 engine was replaced by the Merlin 63 unit early in 1943, giving the Mk.IXc some additional power. The Mk.IX became the second most numerous mark of the Spitfire with a total of 5653 examples built.

ATTENTION



UPOZORNĚNÍ



ACHTUNG



ATTENTION



注意



Carefully read instruction sheet before assembling. When you use glue or paint, do not use near open flame and use in well ventilated room. Keep out of reach of small children. Children must not be allowed to suck any part, or pull vinyl bag over the head.



Před započítím stavby si pečlivě prostudujte stavební návod. Při používání barev a lepidel pracujte v dobře větrané místnosti. Lepidla ani barvy nepoužívejte v blízkosti otevřeného ohně. Model není určen malým dětem, mohlo by dojít k požití drobných dílů.

INSTRUCTION SIGNS \* INSTR. SYMBOLS \* INSTRUKTION SINNBILDEN \* SYMBOLES \* 記号の説明

OPTIONAL  
VOLBABEND  
OHNOUTSAND  
BROUSITOPEN HOLE  
VYVRTAT OTVORSYMETRICAL ASSEMBLY  
SYMETRICKÁ MONTÁŽREMOVE  
ODŘÍZNOUTREVERSE SIDE  
OTOČITAPPLY EDUARD MASK  
AND PAINT  
POUŽIT EDUARD MASK  
NABARVITPLEASE CHECK THE LATEST VERSION OF THE INSTRUCTIONS ON [www.eduard.com](http://www.eduard.com)

PARTS



DÍLY



TEILE



PIÈCES



部品

A&gt;

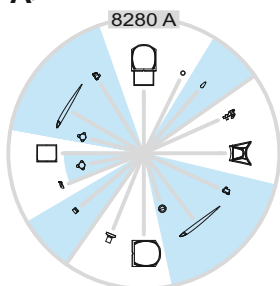

C&gt;

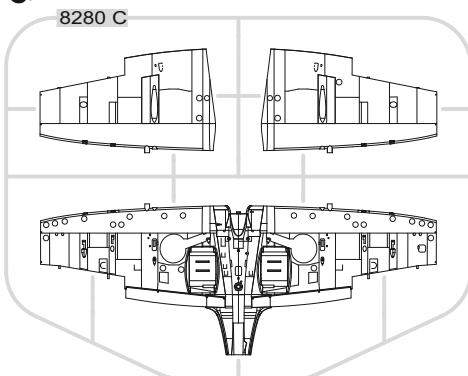

PLASTIC PARTS

E&gt;

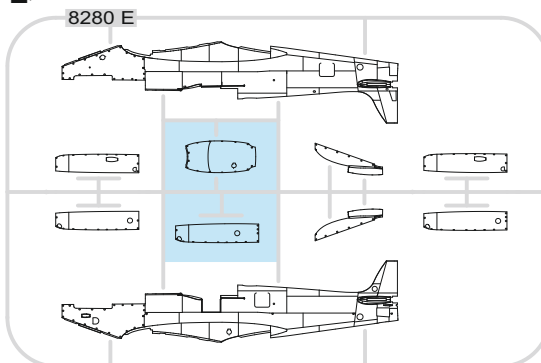

F&gt;

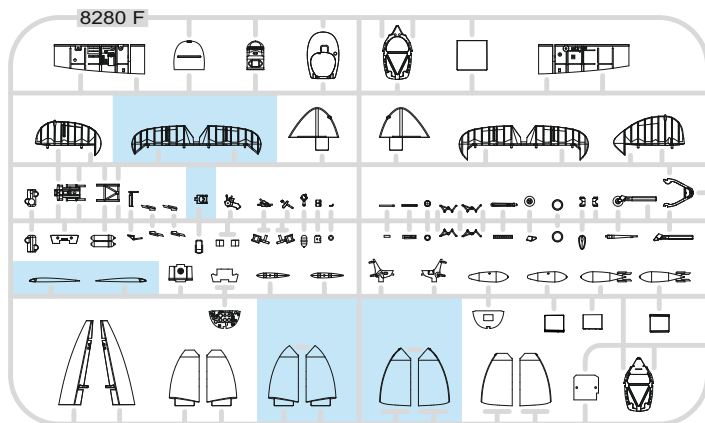

G&gt;

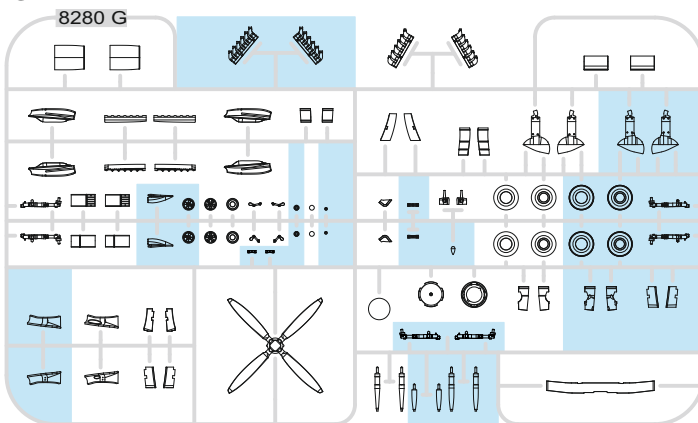

PE - PHOTO ETCHED DETAIL PARTS

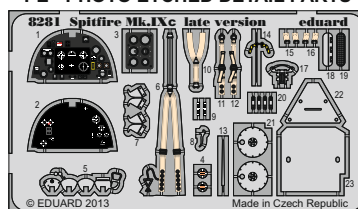

-Parts not for use. -Teile werden nicht verwendet. -Pièces à ne pas utiliser. -Tyto díly nepoužívejte při stavbě. - 使用しない部品

COLOURS



BARVY



FARBEN



PEINTURE



色

GSI Creos (GUNZE)		
AQUEOUS	Mr.COLOR	
H4	C4	YELLOW
H11	C62	FLAT WHITE
H12	C33	FLAT BLACK
H13	C3	FLAT RED
H33	C81	RUSSET
H51	C11	LIGHT GULL GRAY
H52	C12	OLIVE DRAB
H74	C368	SKY
H77	C137	TIRE BLACK
H84	C42	MAHOGANY
H90	C47	CLEAR RED

GSI Creos (GUNZE)		
AQUEOUS	Mr.COLOR	
H94	C138	CLEAR GREEN
H330	C361	DARK GREEN
H335	C363	MEDIUM SEAGRAY
	C362	OCEAN GRAY
	C364	AIRCRAFT GRAY-GREEN
Mr.METAL COLOR		
MC214		DARK IRON
MC218		ALUMINIUM
Mr.COLOR SUPER METALLIC		
SM201		SUPER FINE SILVER

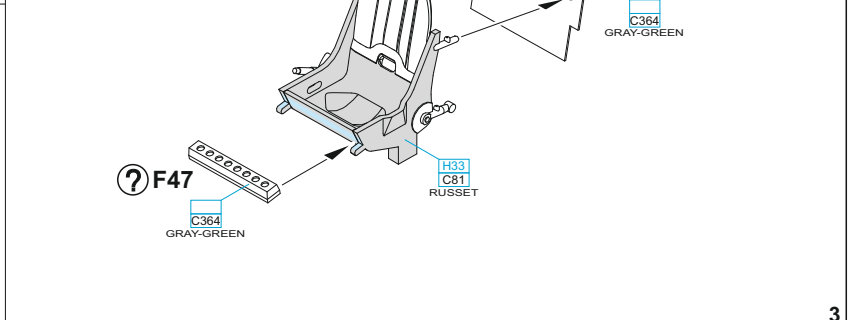
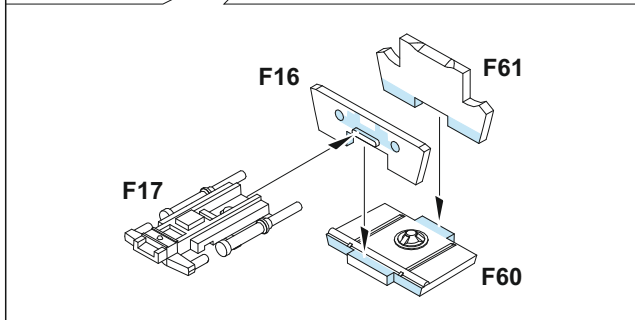
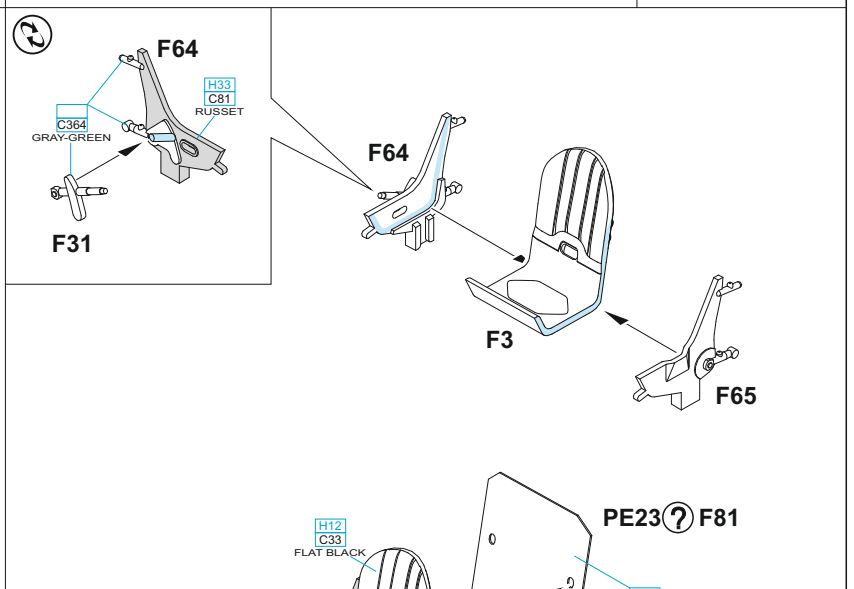
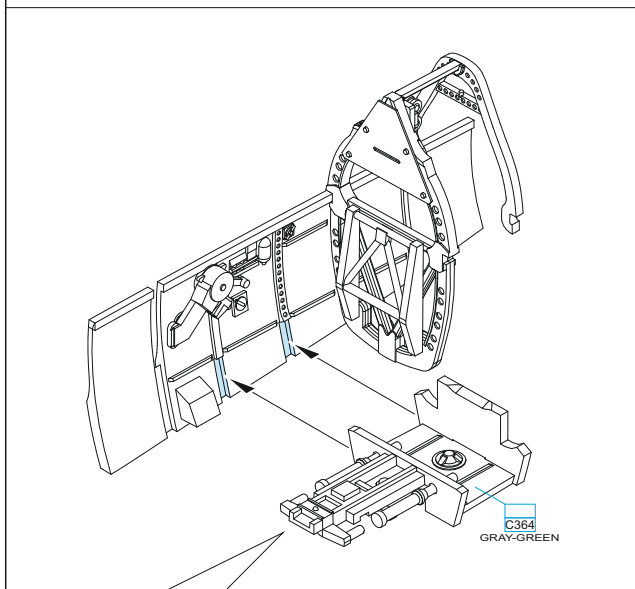
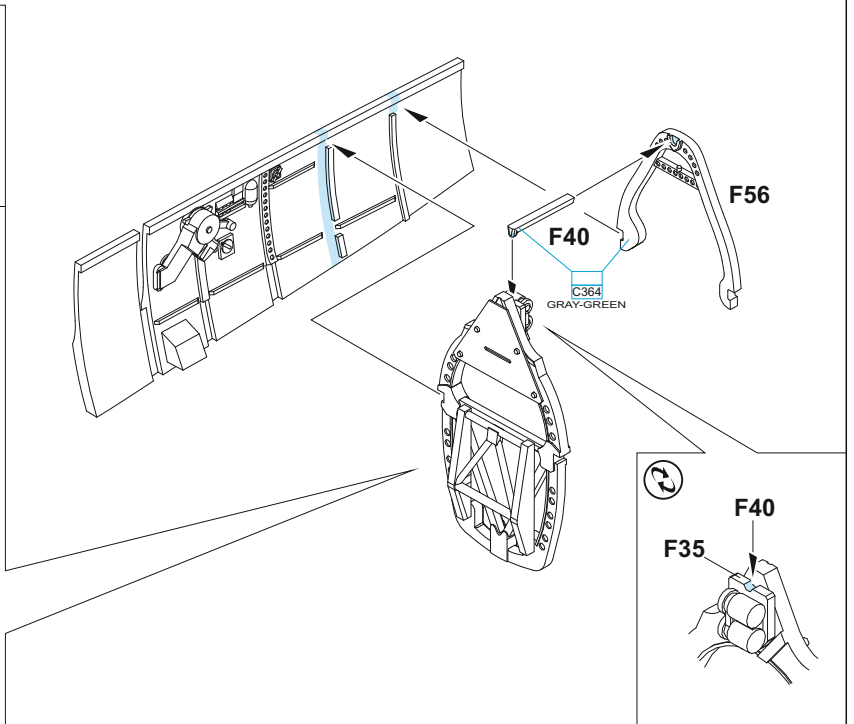
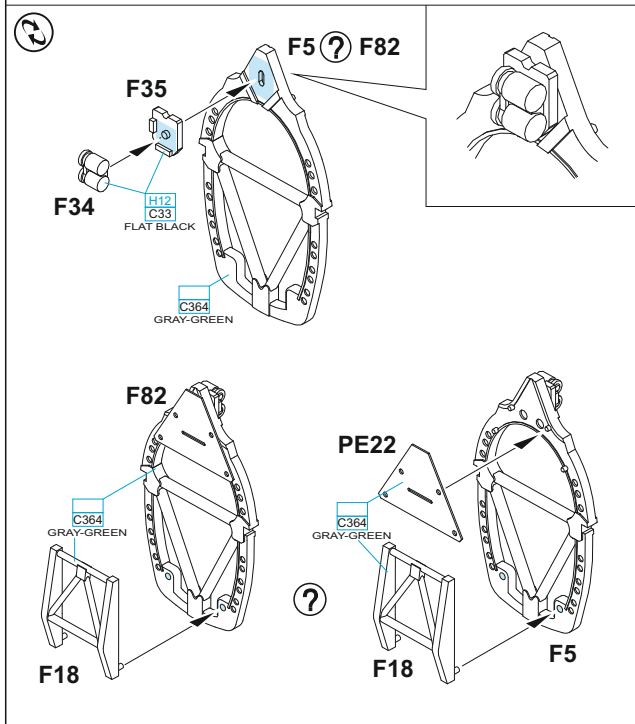
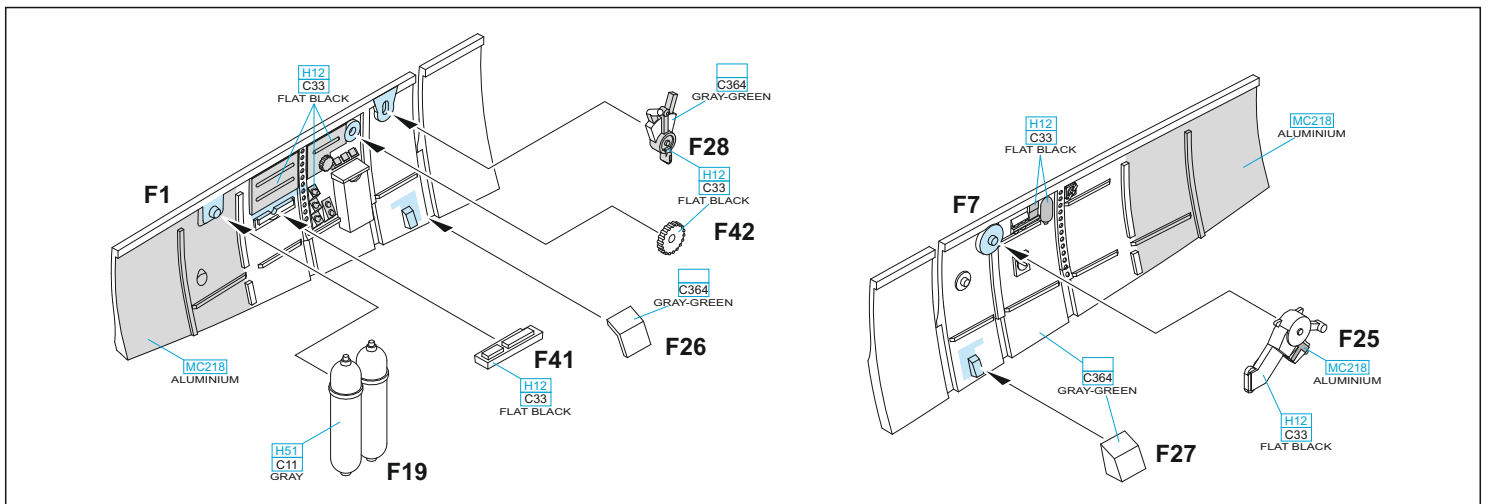

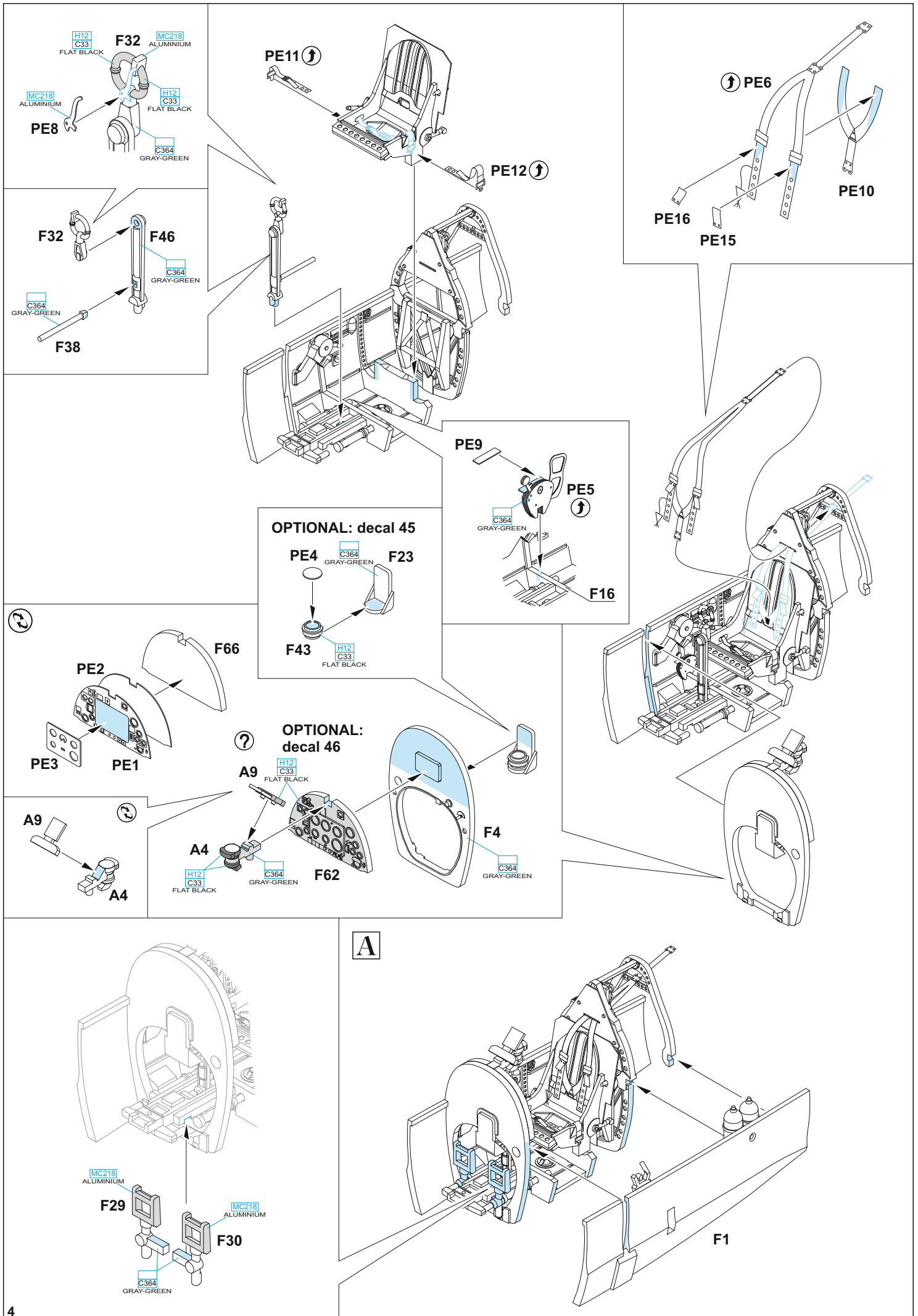

FOR CLOSED CANOPY ONLY

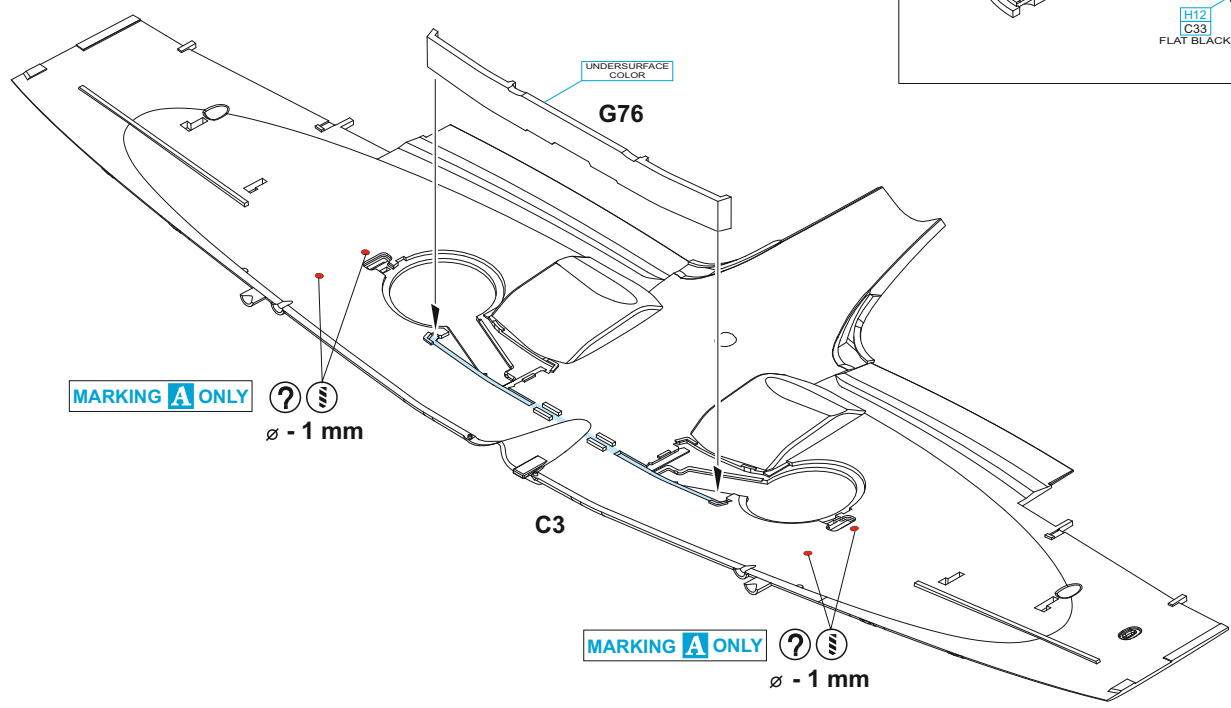
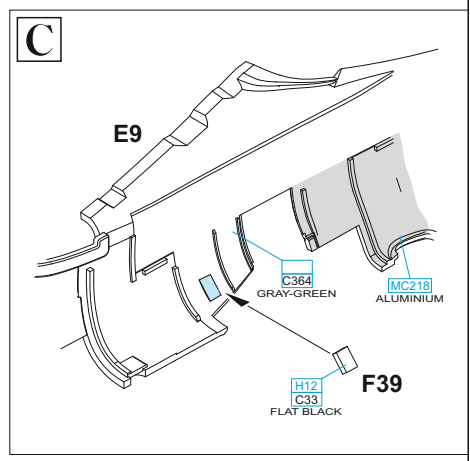
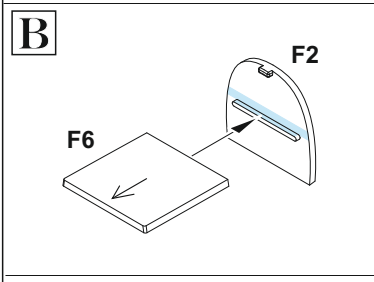
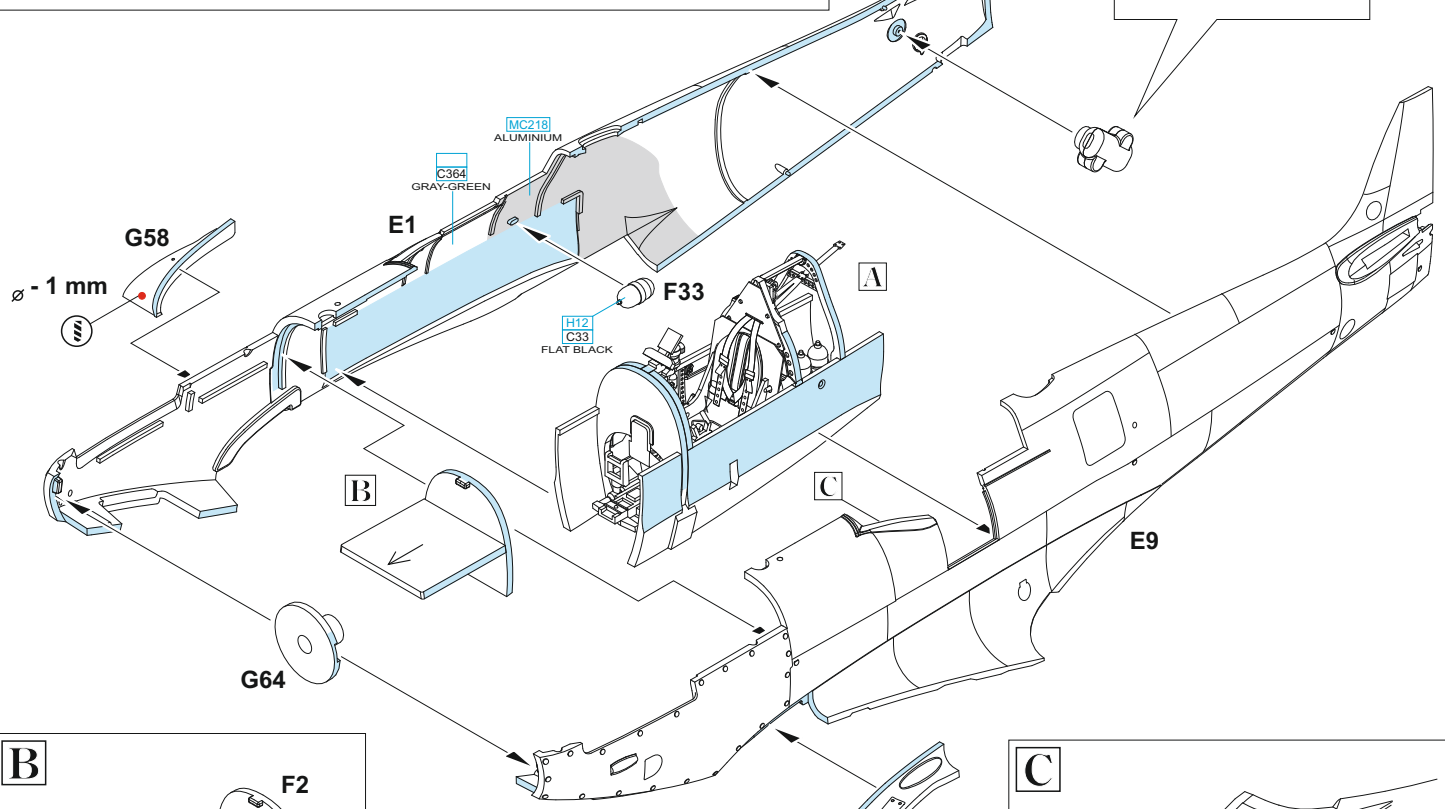
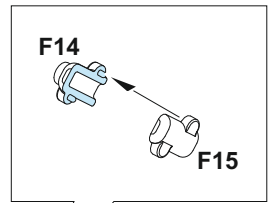
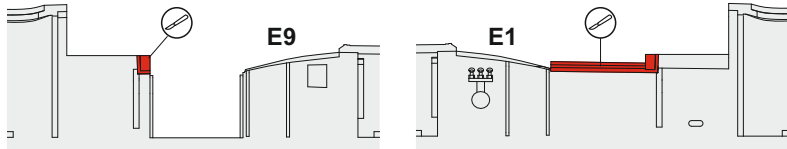

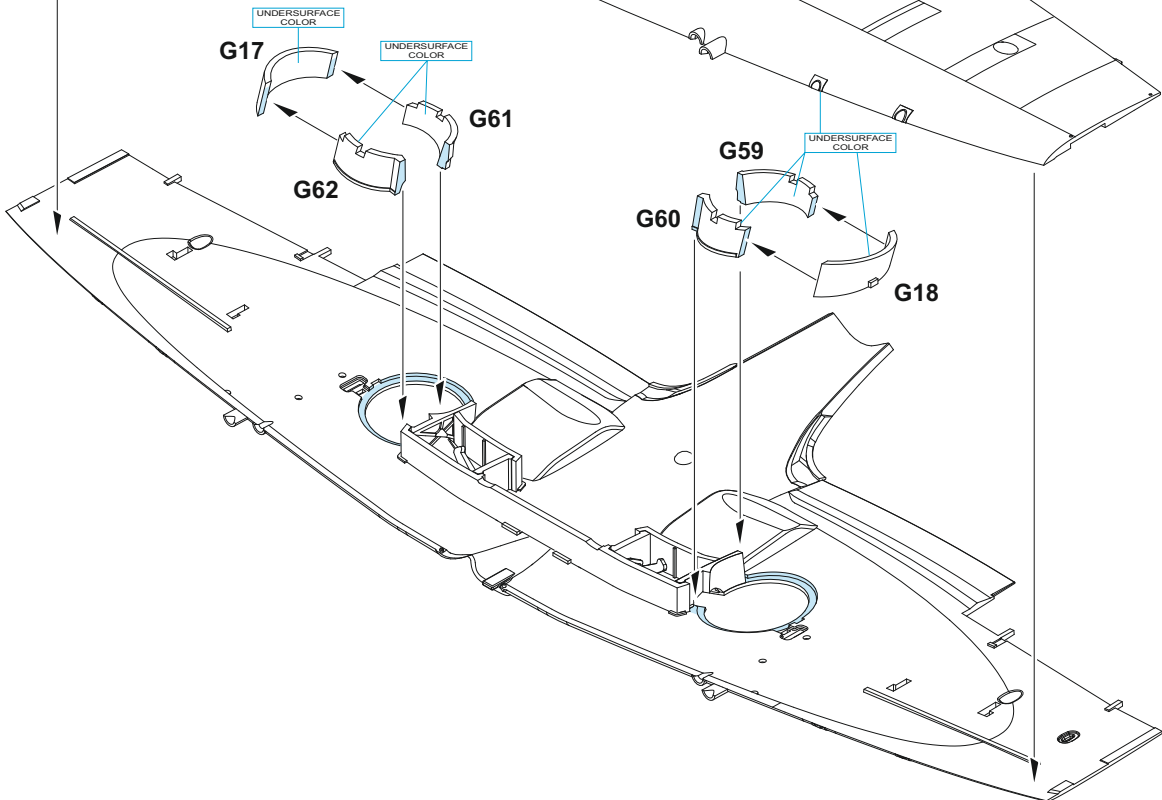
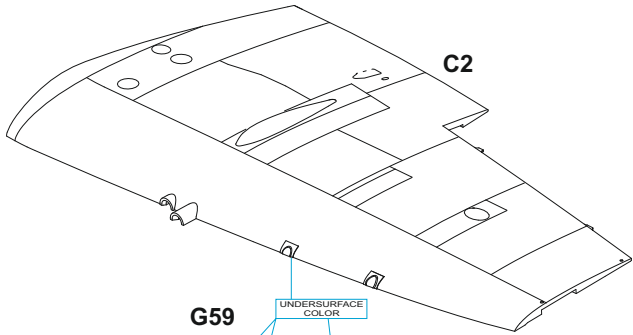
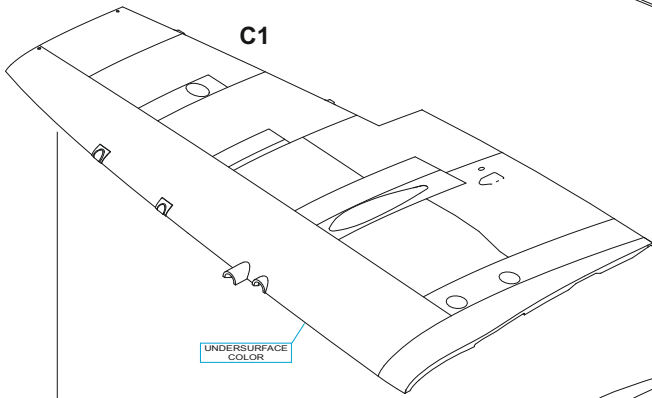
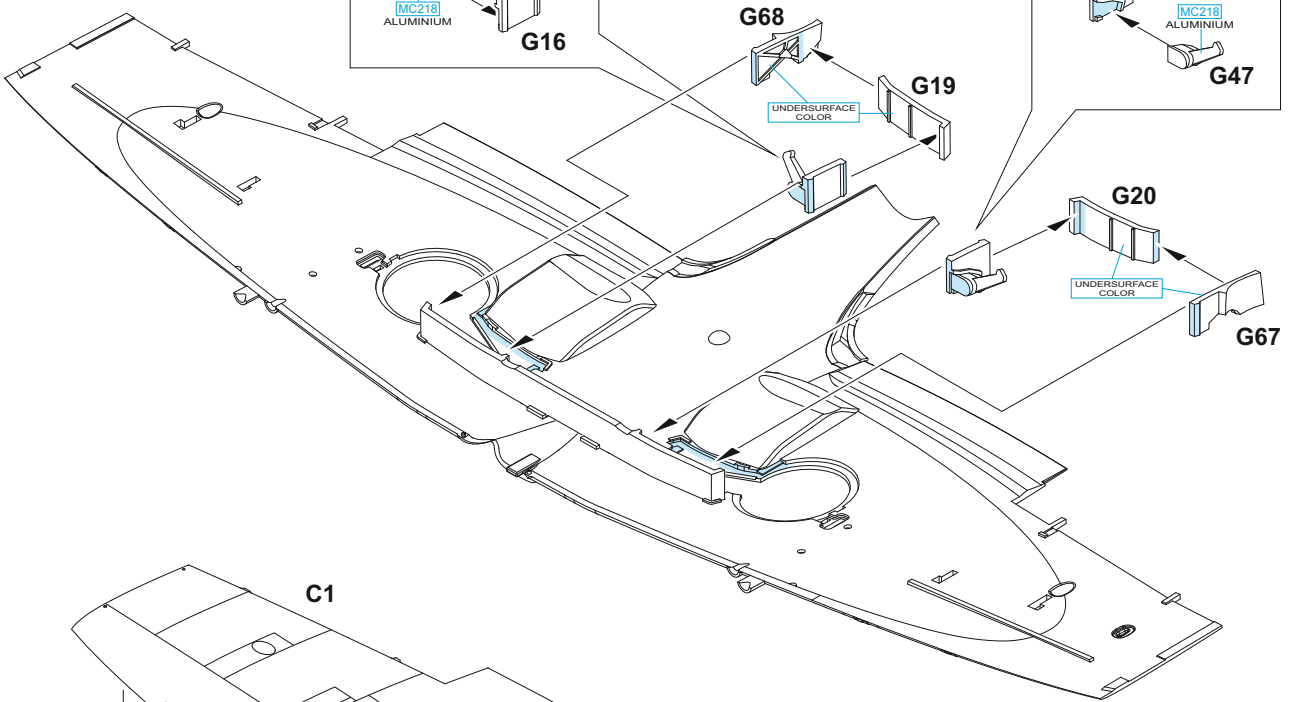
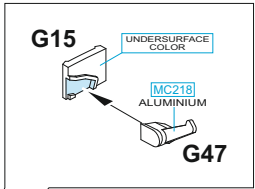
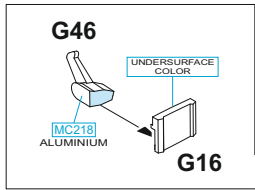

E2, E3 - MARKING **B** ONLY

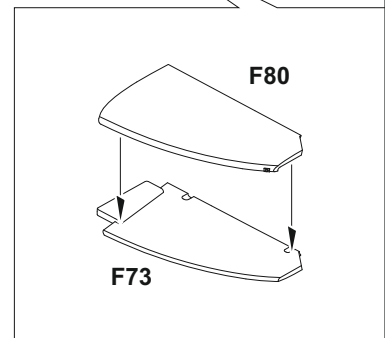
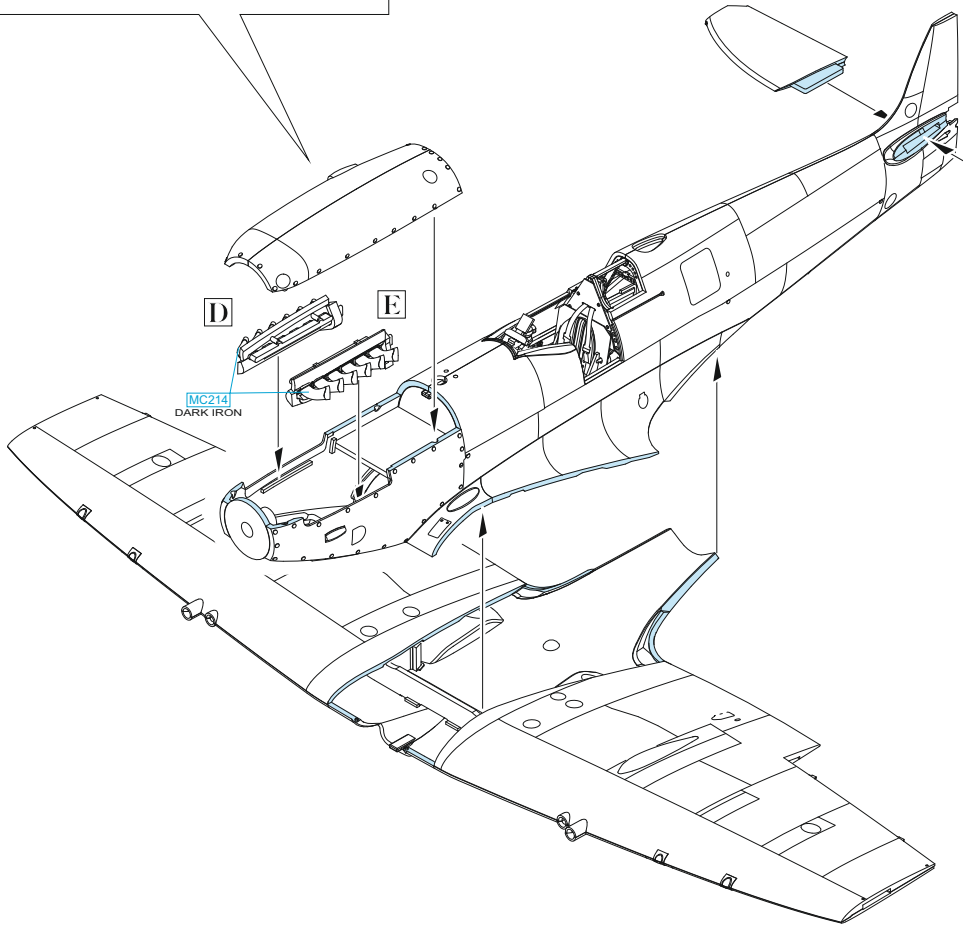
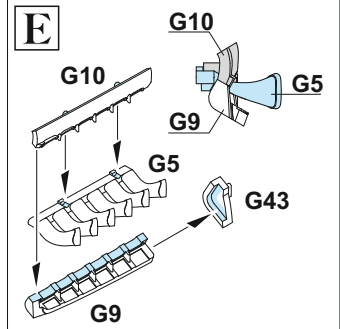
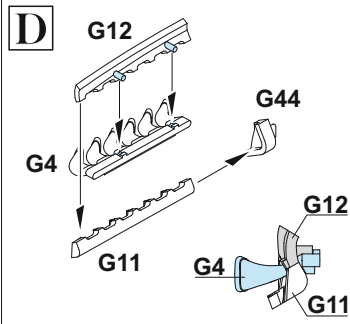
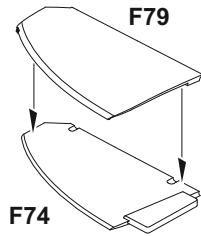
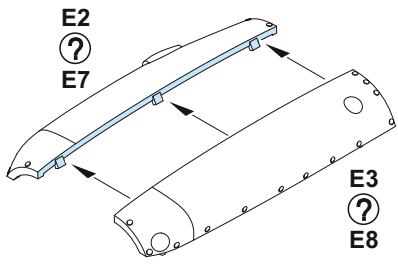

GLUE PARTS F52 & F53 ONE BY ONE

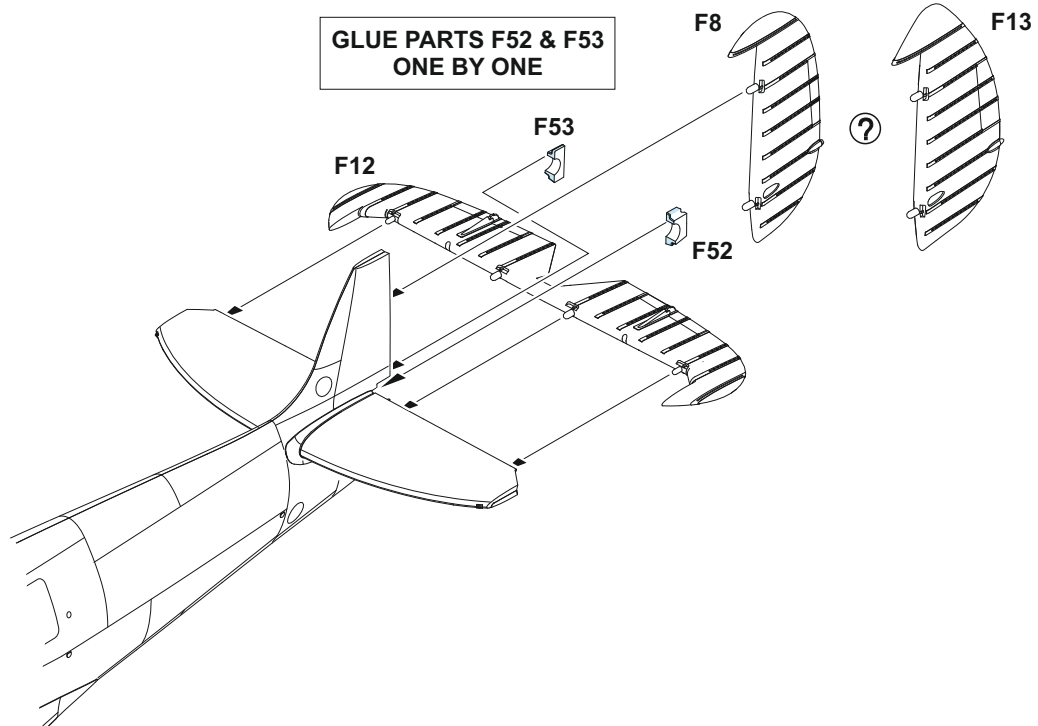

F13 - MARKING **A** ONLY

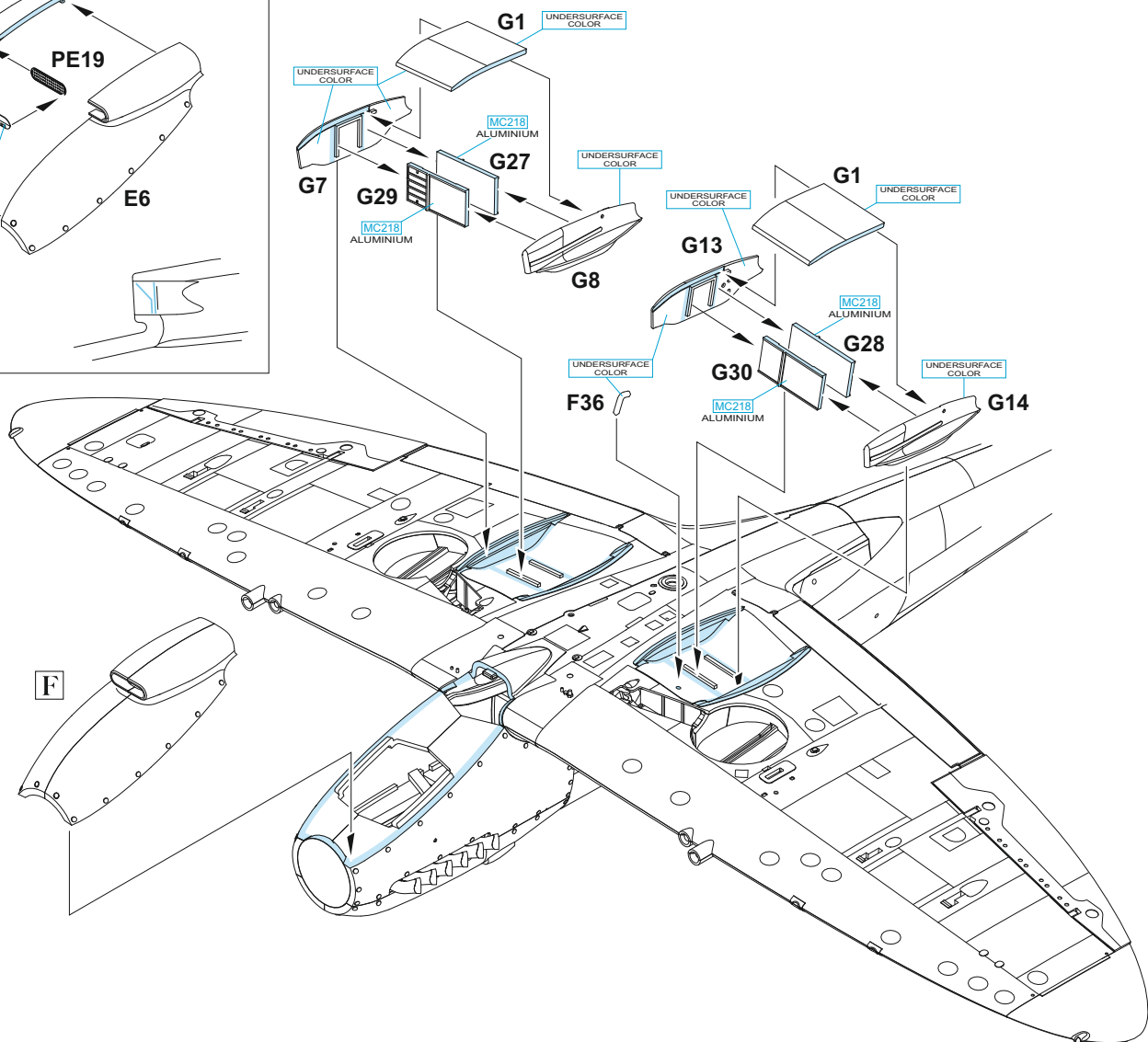
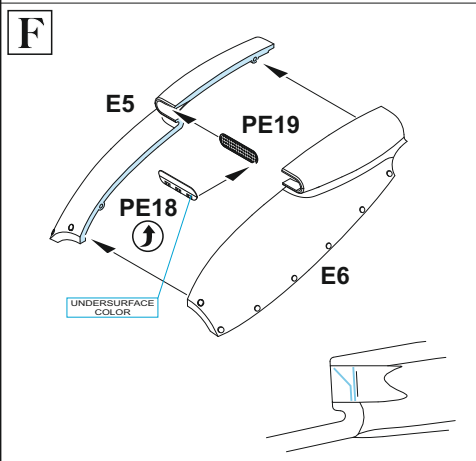
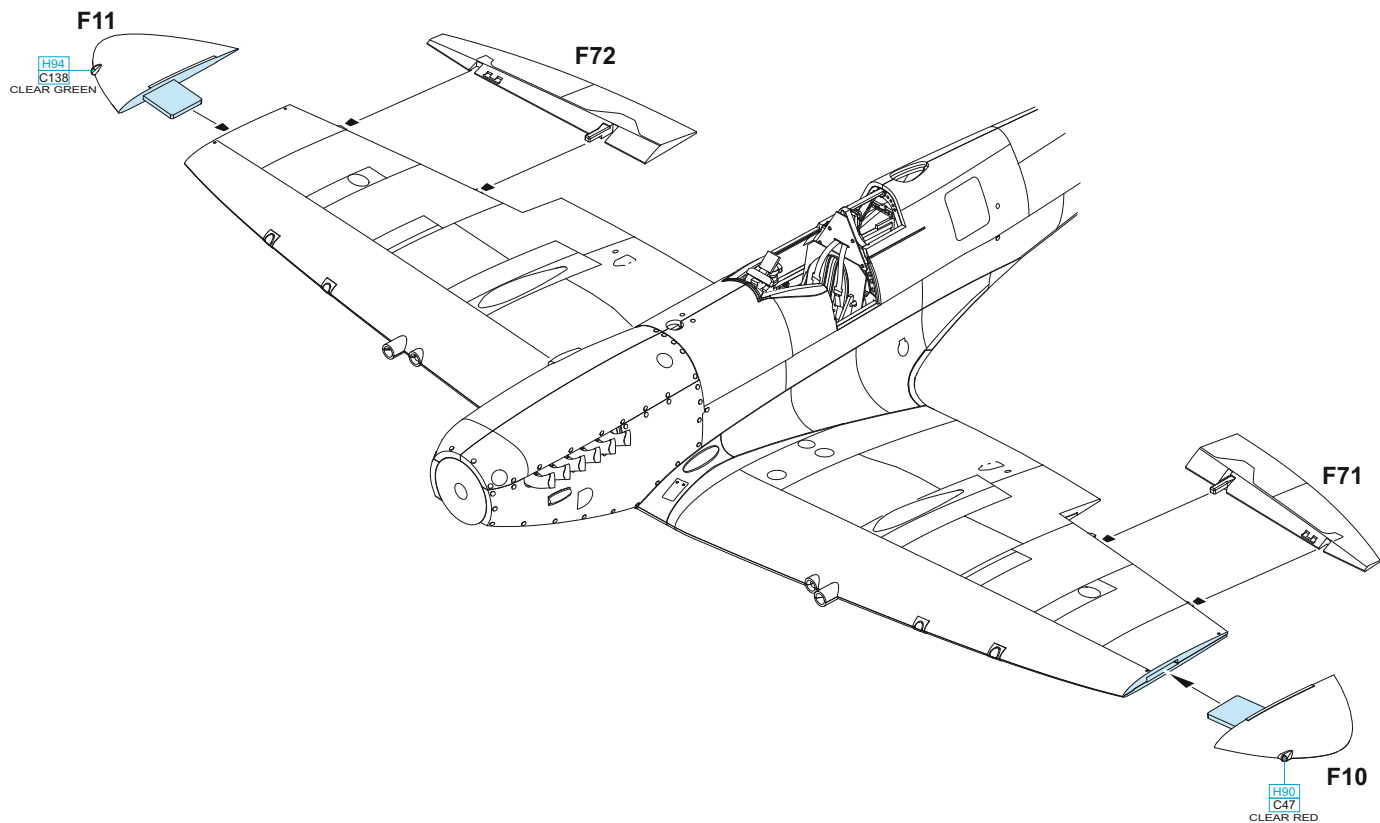



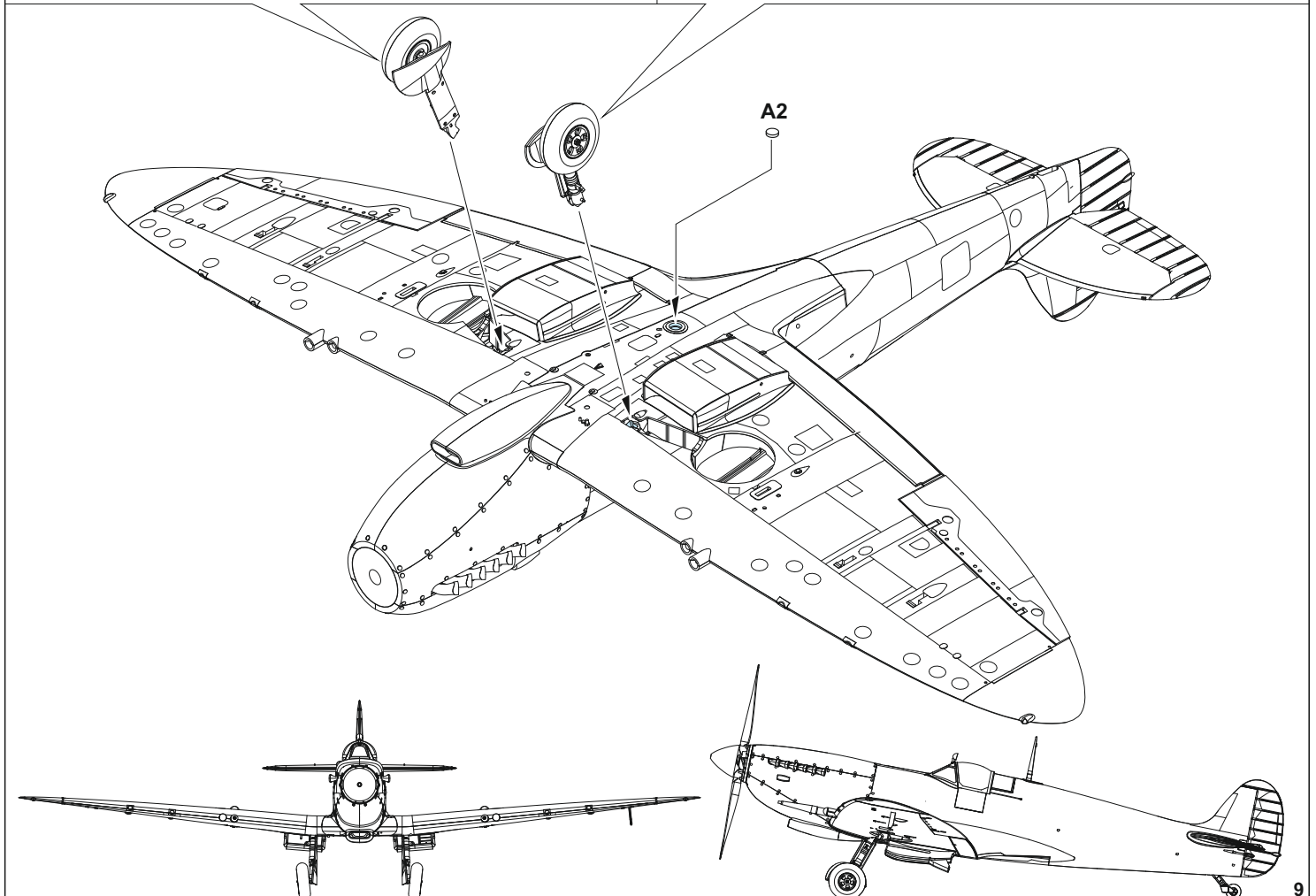
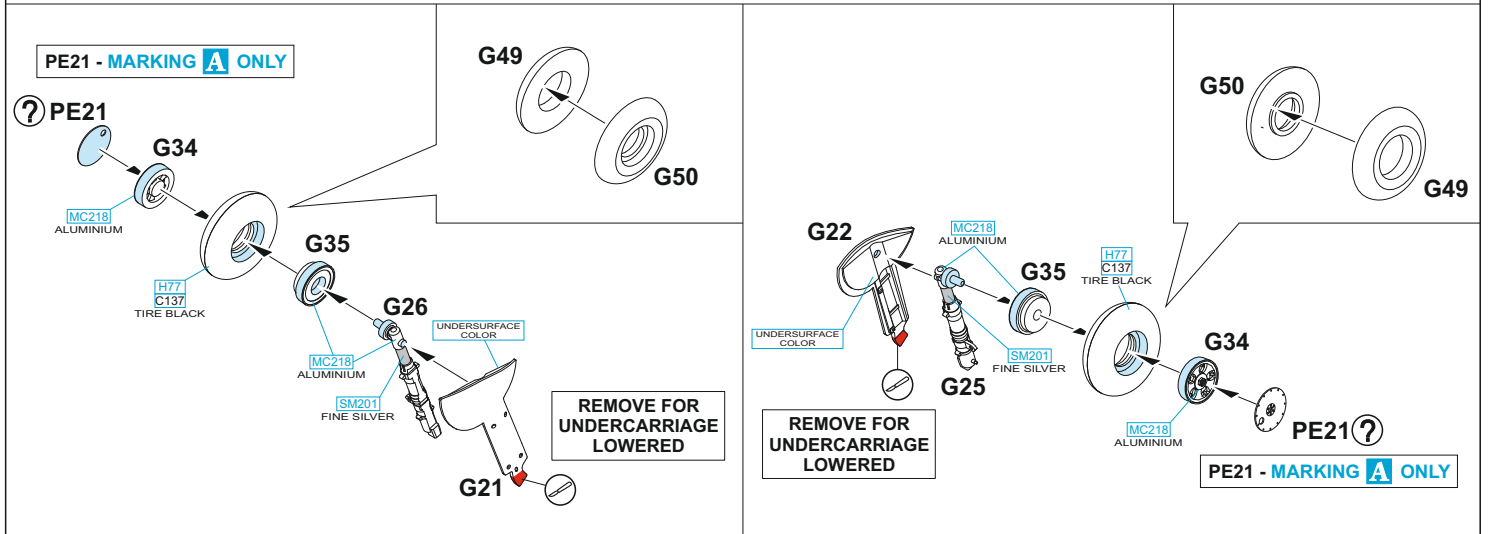
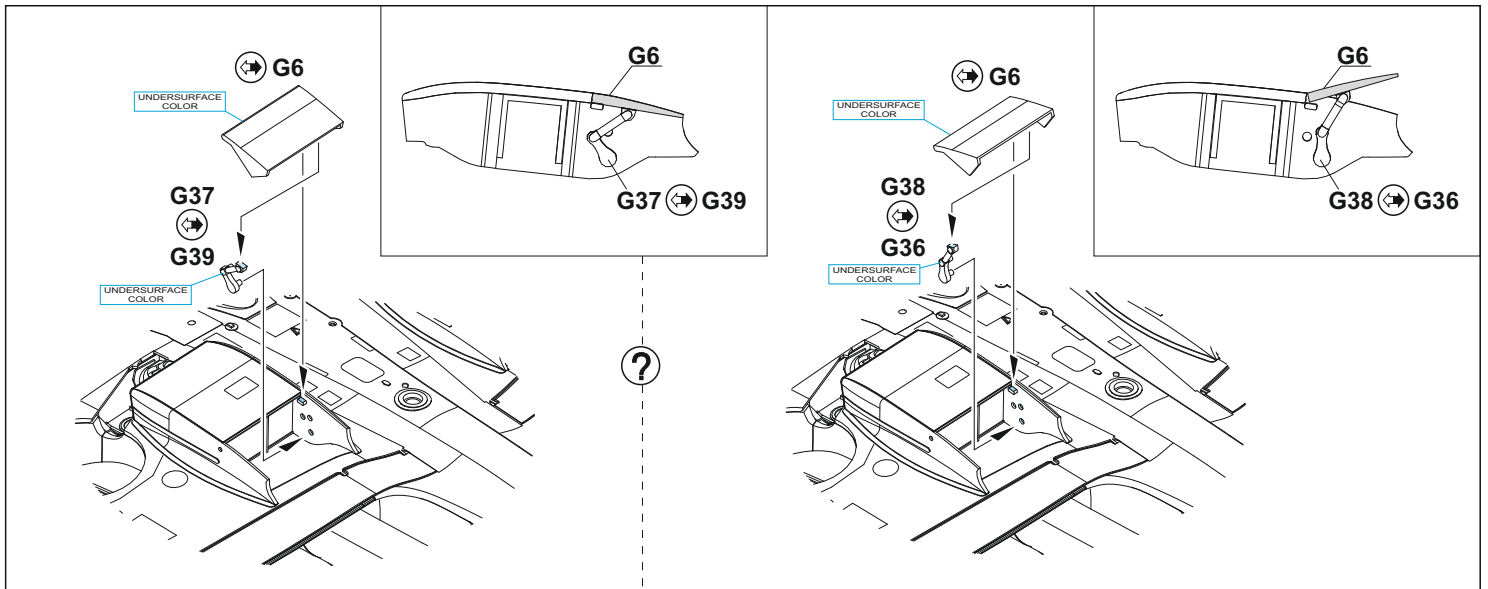

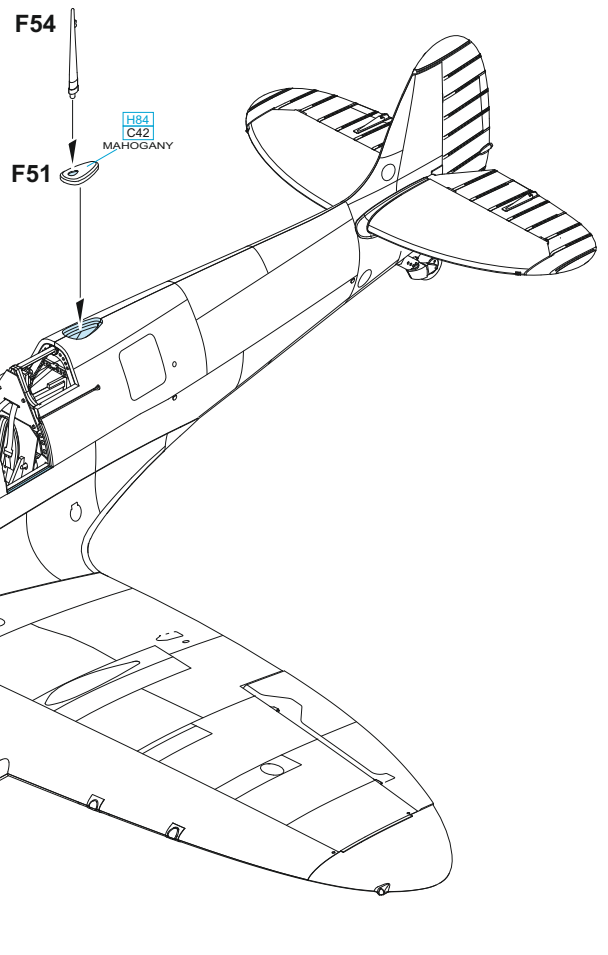
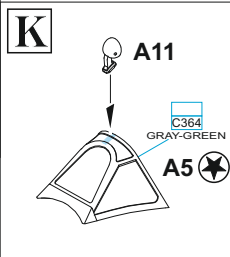
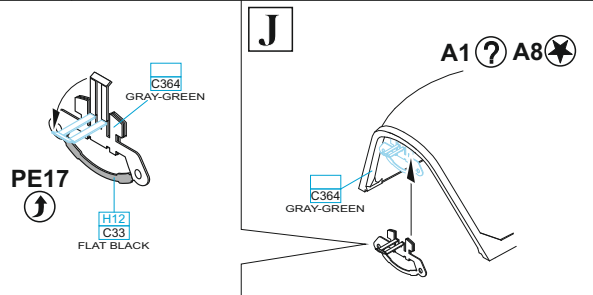
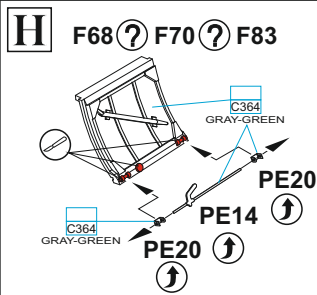
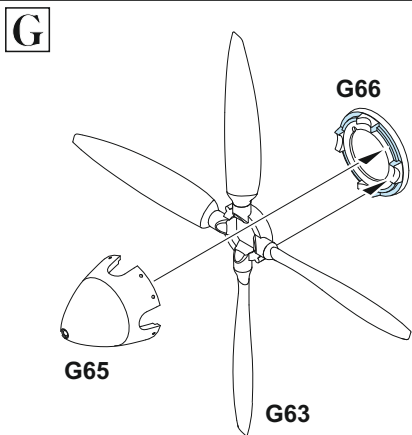
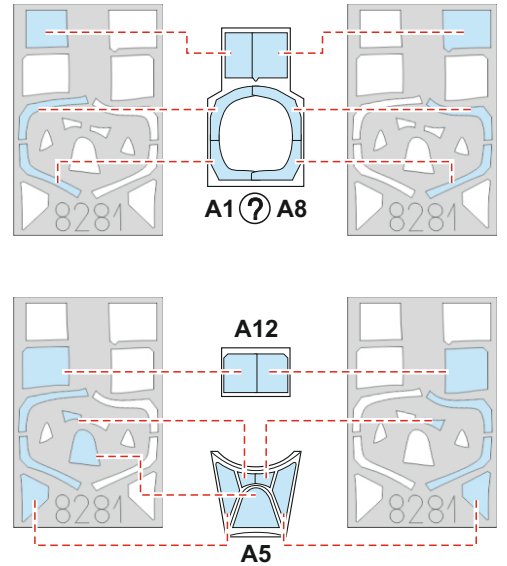
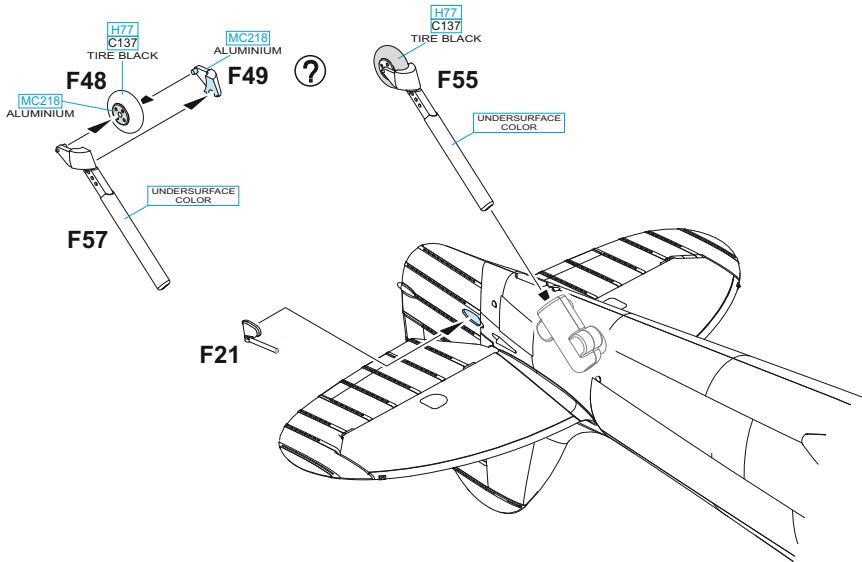

**CLOSED CANOPY**

**OPEN CANOPY**

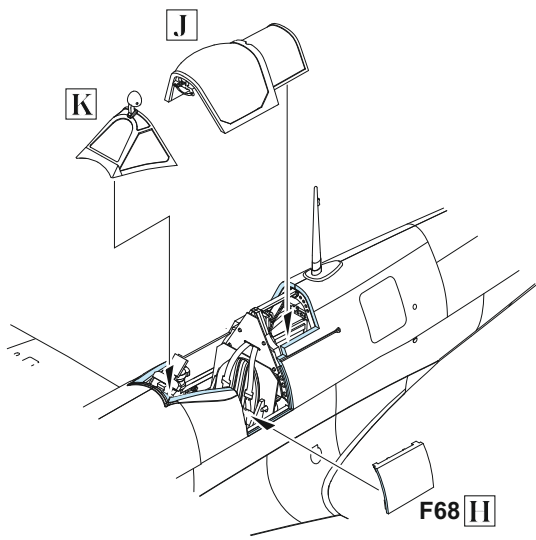

?

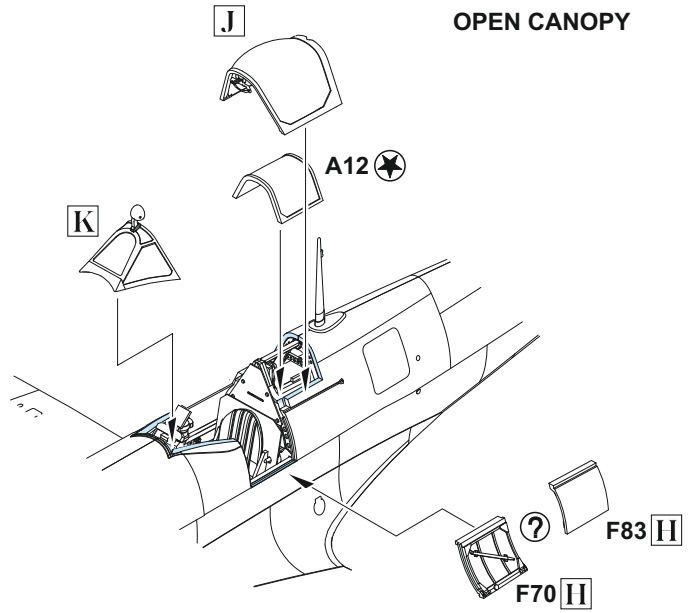

**MARKING A ONLY** 2 pcs.

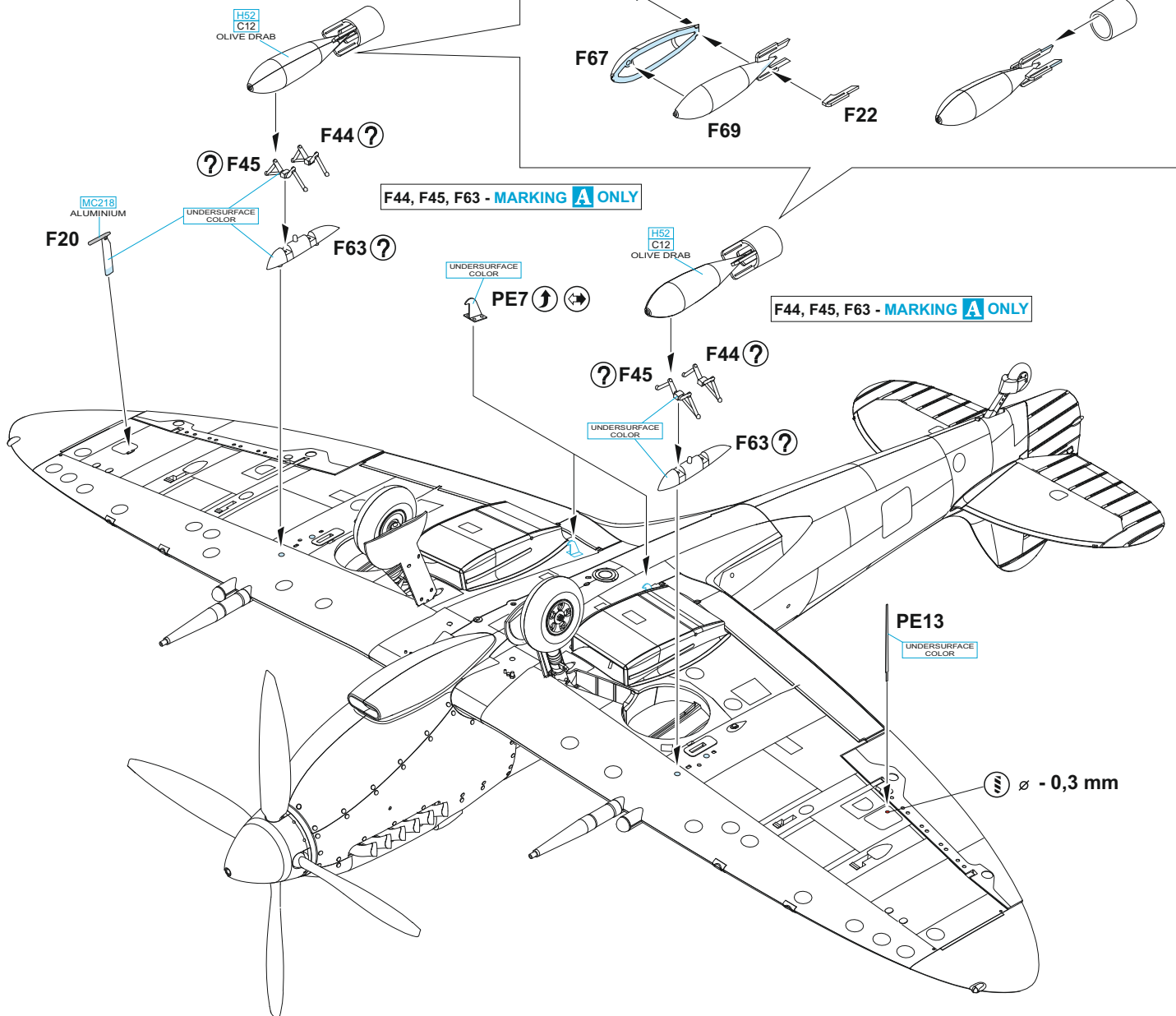
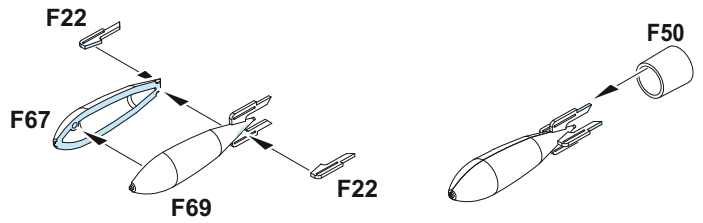

# A Spitfire LF Mk.IXc, MH712, W/O Henryk Dygala, No. 302 (Polish) Sqn., ALG G10 Plumetot, France, August 1944

The No. 302 (Polish) Squadron was one of the units that participated in the invasion of Normandy in June 1944. The D-Day Invasion Stripes painted on the bottom of the fuselage and wings indicated it as well. This aircraft was equipped with wing racks for 250lb bombs. The pointed rudder was freshly painted and so the colors appeared darker than on the rest of the aircraft. Nose art paintings were not common within the RAF, so this one, the girl sitting on the bomb, is one of exceptions. The Polish stencil right of the cockpit door "Wycierac obuwie" means "Wipe your shoes".

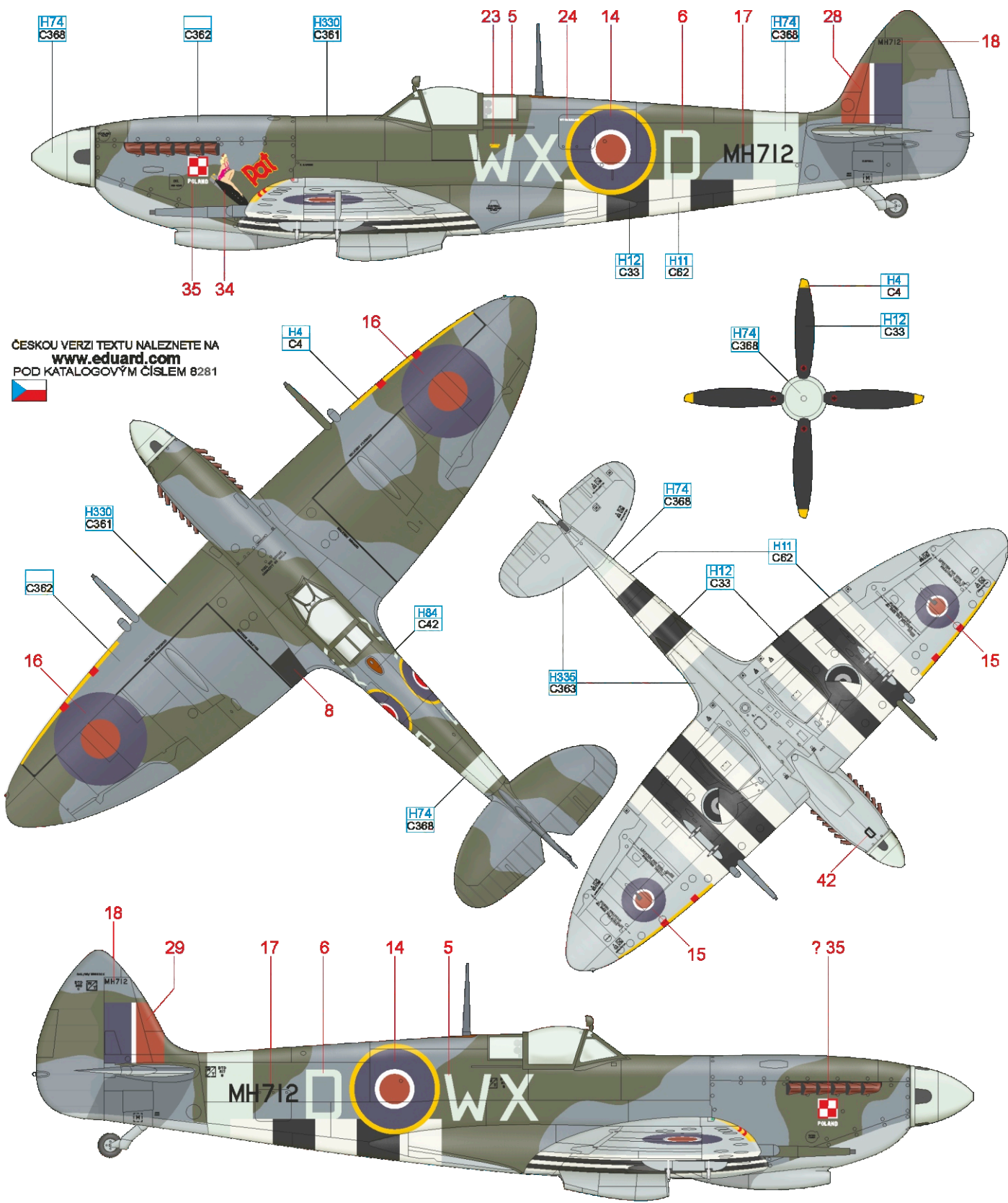

WHITE	H11 C62	YELLOW	H4 C4	MAHOGANY	H84 C42
SKY	H74 C368	MEDIUM SEA GRAY	H335 C363	OCEAN GRAY	C362
		DARK GREEN	H330 C361	BLACK	H12 C33

# B Spitfire HF Mk.IXc, MJ296, F/Lt Otto Smik, No. 312 (Czechoslovak) Sqn., RAF North Weald, United Kingdom, August 1944

This Spitfire was flown by F/Lt Otto Smik, the CO of B Flight of No. 312 (Czechoslovak) Squadron. On the cockpit door 8.5 confirmed aircraft plus three V-1 kill marks were painted as his personal score of that time. Smik was flying this Spitfire during July and August on strafing missions over occupied Europe. He was shot down by AA fire during an attack on Gilze-Rijen Air Base but survived and with the help of the Dutch resistance, he returned to Great Britain. Smik met his fate on November 28, 1944, when he was killed during attack on the Zwolle railway station. The camouflage and marking of this Spitfire were typical for No. 312 (Czechoslovak) Sqn. with the unit badge painted on both sides of the cowling. Available photos do not reveal the type of the rudder. The MJ296 could have had either the rounded or pointed type.

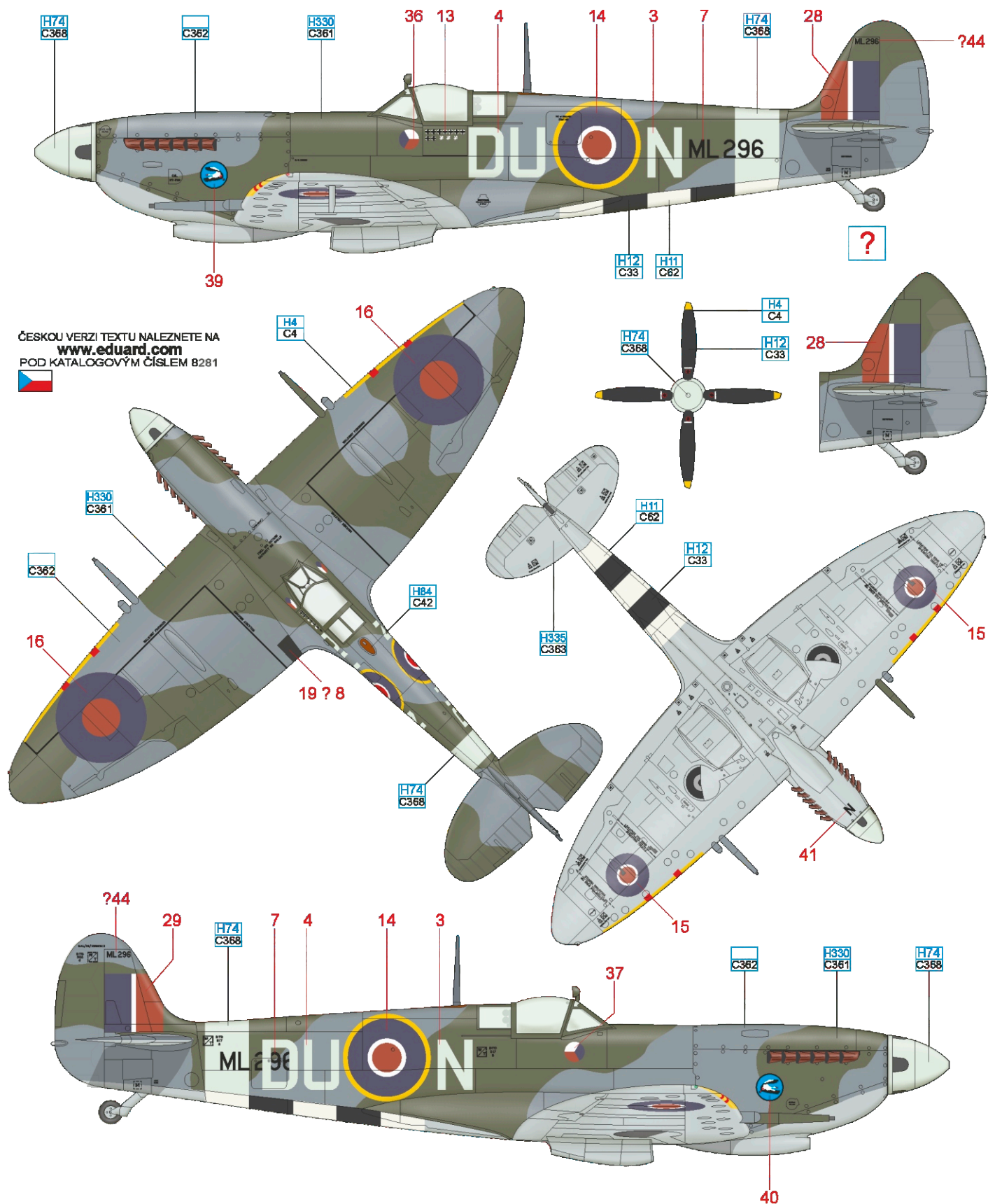

ČESKOU VERZI TEXTU NALEZNETE NA  
[www.eduard.com](http://www.eduard.com)  
 POD KATALOGOVÝM ČÍSLEM B281



YELLOW	H4 C4	BLACK	H12 C33	MAHOGANY	H84 C42	FLAT WHITE	H11 C62
SKY	H74 C368	MEDIUM SEA GRAY	H335 C363	OCEAN GRAY	C362	DARK GREEN	H330 C361

# C Spitfire LF Mk.IXc, MJ586, S/Lt. Pierre Clostermann, No. 602 Sqn., Longues-sur-Mer, France, July 1944

Pierre Clostermann, a famous French fighter ace, became known worldwide thanks to his book "Le Grand Cirque" (The Big Show) as well. One of the aircraft he was flying during the war was Spitfire MJ586. Clostermann's score of seven confirmed, three probable and seven damaged enemy aircraft was portrayed below windshield. French sources credit Clostermann with 20 kills, but it has been a topic of debate for many years. The post war French figures are inconsistent with those of wartime documentation in British archives due to different methodology of these two Air Forces. At the end of WWII, Clostermann flew Tempests with No. 3 Squadron RAF. Note the squadron badge on both sides of the engine cowling.

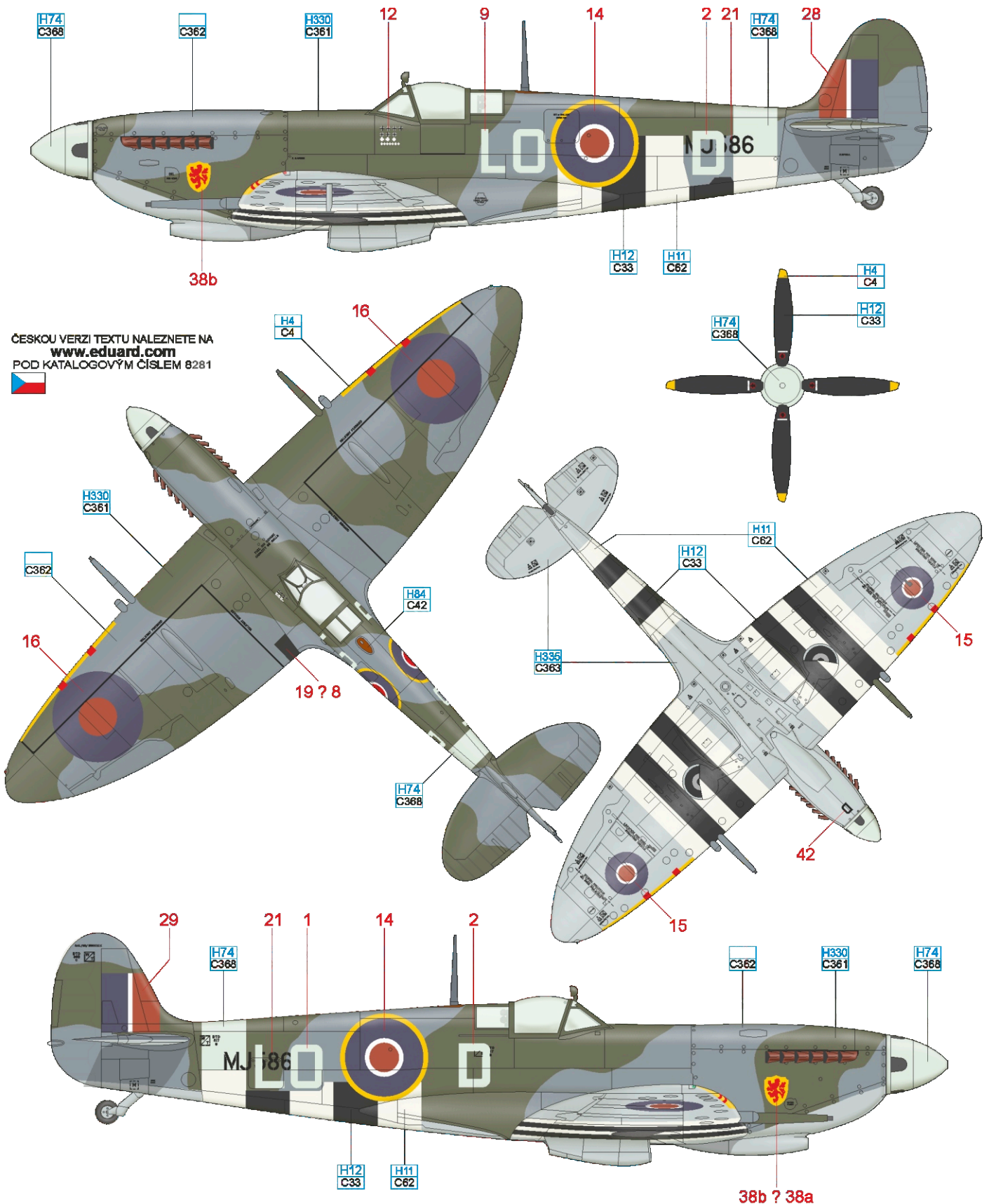

ČESKOU VERZI TEXTU NALEZNETE NA  
[www.eduard.com](http://www.eduard.com)  
 POD KATALOGOVÝM ČÍSLEM 8281



WHITE	H11 C62	YELLOW	H4 C4	MAHOGANY	H84 C42
SKY	H74 C368	MEDIUM SEA GRAY	H335 C363	OCEAN GRAY	C362
		DARK GREEN	H330 C361	BLACK	H12 C33

# D Spitfire LF Mk.IXc, MJ250, F/O Desmond Ibbotson, No. 601 Sqn., Italy, Summer, 1944

MJ250 was flown by No. 601 "County of London" Squadron from July 1944. The unit was operating from the airfields at Perugia, Loreto and Fano at that time. The aircraft was used primarily for dive-bombing operations. MJ250 survived the war but was scrapped shortly afterward. The MJ250 was regularly flown by F/O Desmond Ibbotson, DFC & Bar who is credited with 11 confirmed and four probable kills plus five damaged aircraft. He died on November 19, 1944 at the controls of Spitfire MH614. The camouflage colors of MJ250 were removed except for the upper engine and fuel tank cowling. These parts seem to be taken from another aircraft which retained the camouflage colors. Note the unit badge on the fin tip.

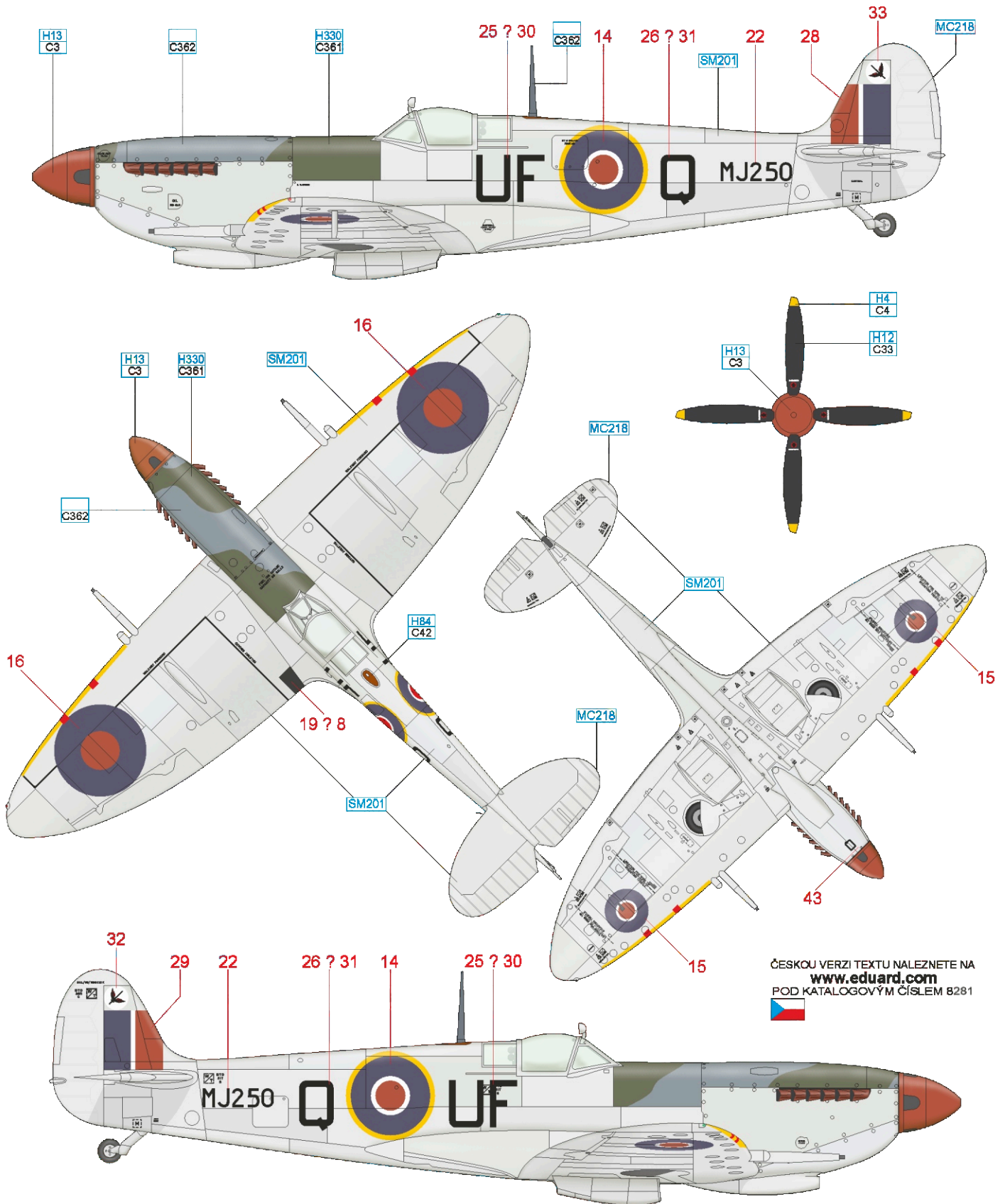

ČESKOU VERZI TEXTU NALEZNETE NA  
**www.eduard.com**  
 POD KATALOGOVÝM ČÍSLEM 8281

SUPER FINE SILVER 2	SM201	YELLOW	H4 C4	MAHOGANY	H84 C42
ALUMINIUM	MC218	RED	H13 C3	OCEAN GRAY	C362
				DARK GREEN	H330 C361
				BLACK	H12 C33

# E Spitfire LF Mk.IXc, ML135, P/O Jerry Billing, No. 401 Sqn., RAF Tangmere, United Kingdom, June 7, 1944

Jerry Billing was one of many Canadians serving with RAF. He volunteered in October 1942 to help the Malta defense. After joining No. 185 Squadron, he fought over the island until March 1943, when he was downed by a Bf 109. Billing was transferred to No. 401 Squadron in 1944. He downed a Ju 88 bomber and damaged two Fw 190s on June 7, 1944, the second day of the invasion of Normandy. On July 1, 1944, his Spitfire ML135 was hit by AA fire and Billing belly-landed in no-man's land in France. He managed to get back to the UK with the help of a French family. After WWII, Jerry Billing re-enlisted in the Royal Canadian Air Force and became an instructor. In 1951 he joined the Blue Devils, a Canadian aerobatics team flying Vampire jets. Billing left the RCAF in 1964, becoming DeHavilland test pilot.

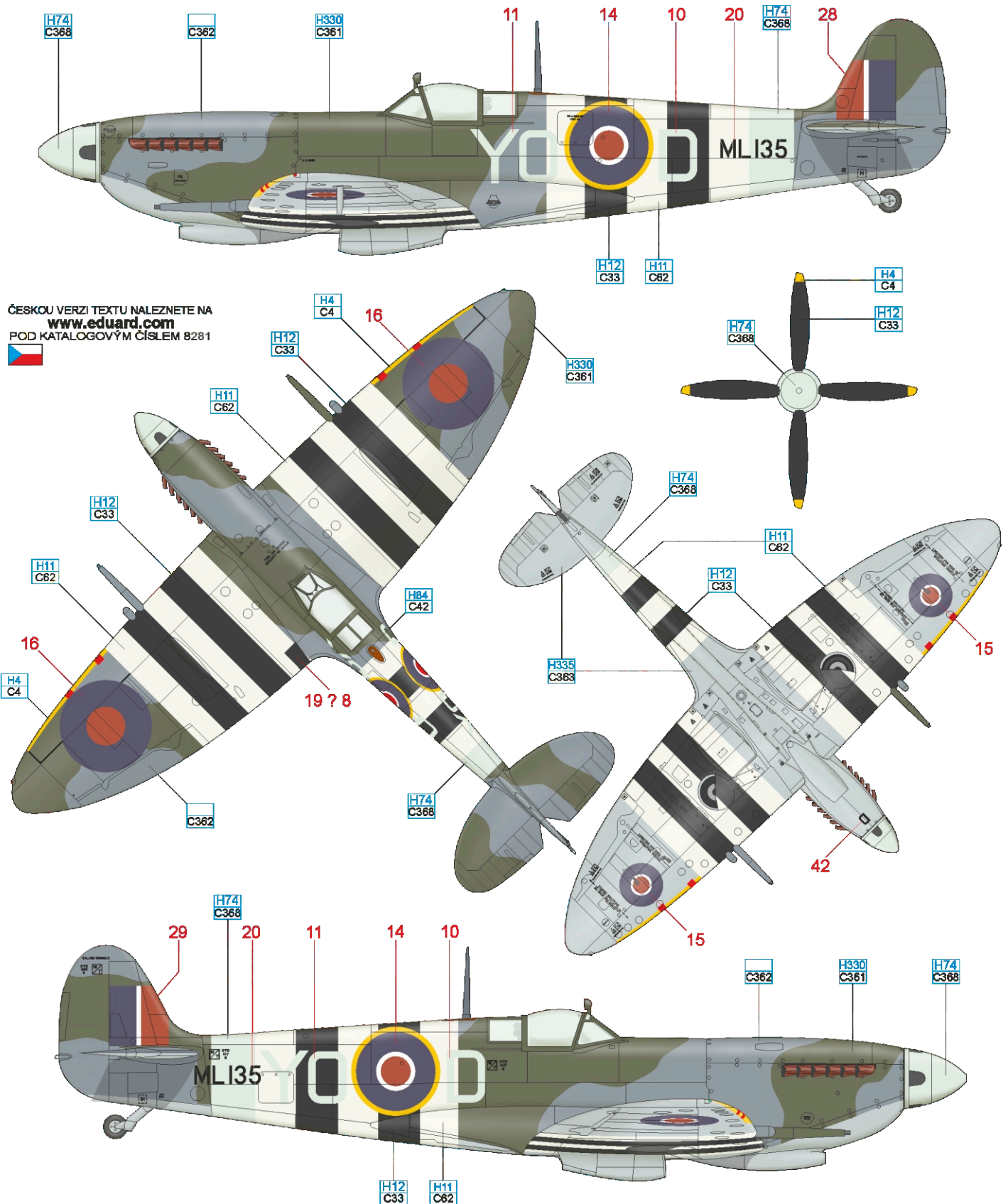

ČESKOU VERZI TEXTU NALEZNETE NA  
[www.eduard.com](http://www.eduard.com)  
 POD KATALOGOVÝM ČÍSLEM 8281



WHITE	H11 C62	YELLOW	H4 C4	MAHOGANY	H84 C42
SKY	H74 C368	MEDIUM SEA GRAY	H335 C363	OCEAN GRAY	C362
		DARK GREEN	H330 C361	BLACK	H12 C33



# F Spitfire LF Mk.IXc, ML 135, P/O Jerry Billing, No. 401 Sqn., France, July 1, 1944

Jerry Billing was shot down at the controls of ML135 on July 1, 1944 and belly-landed seven miles south of Carentan, France. The D-Day stripes were left on the undersides only and the female name "Dorothy" appeared under the windscreen.

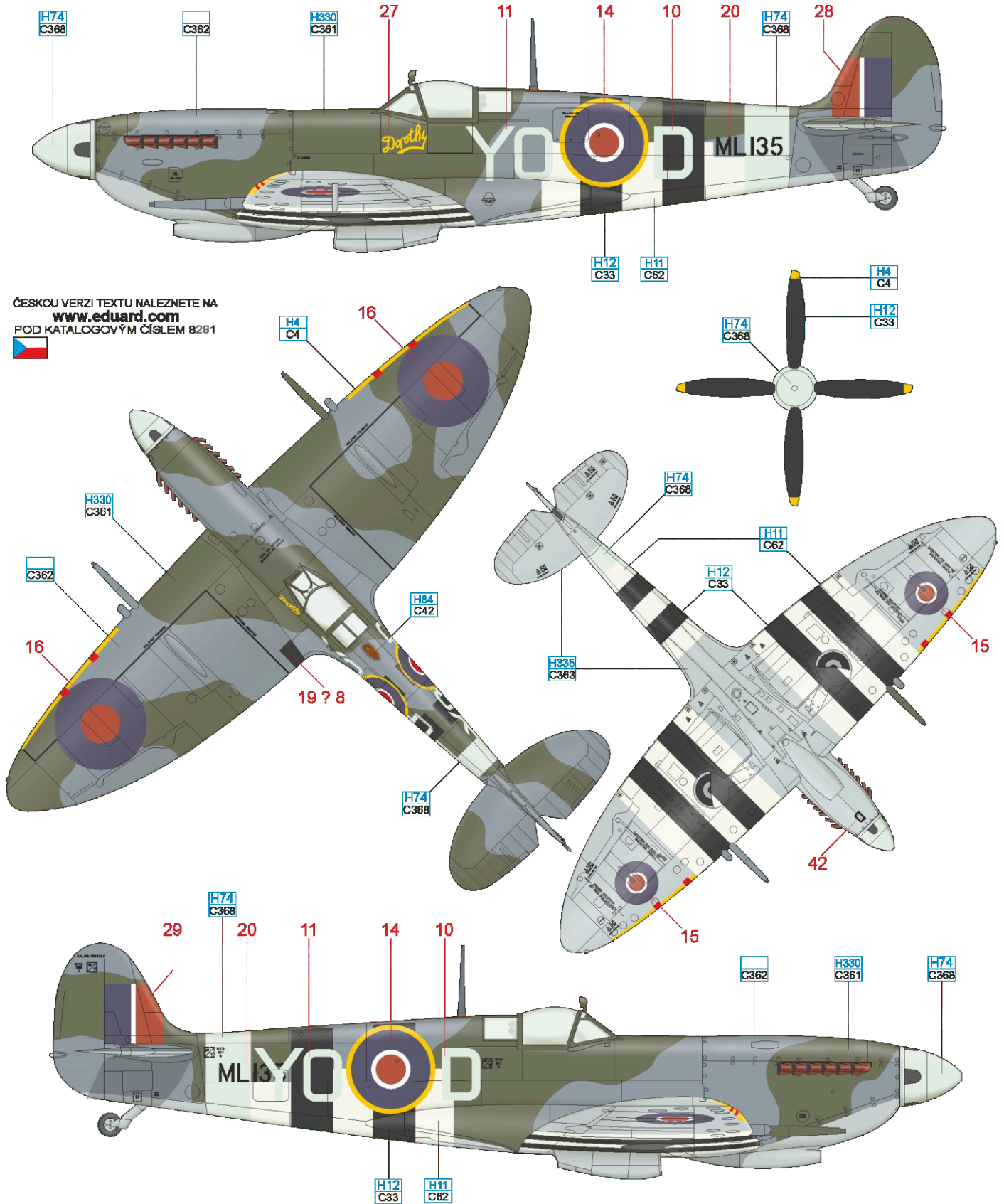

ČESKOU VERZI TEXTU NALEZNETE NA  
[www.eduard.com](http://www.eduard.com)  
 POD KATALOGOVÝM ČÍSLEM 8281



WHITE	H11 C62	YELLOW	H4 C4	MAHOGANY	H84 C42
SKY	H74 C368	MEDIUM SEA GRAY	H335 C363	OCEAN GRAY	C362
		DARK GREEN	H330 C361	BLACK	H12 C33

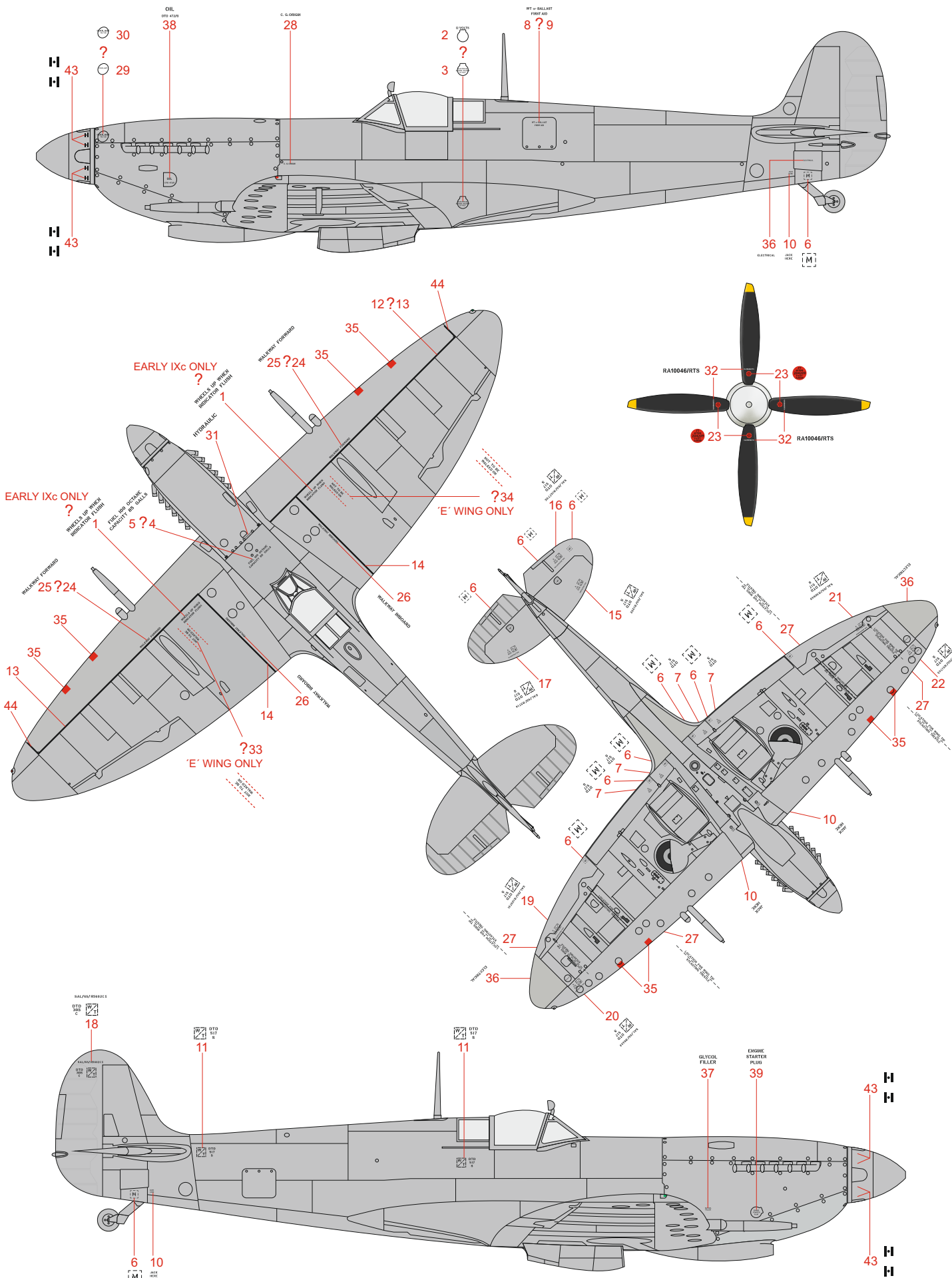

# EXTRAS...

**eduard**  
**BRASSIN**



648100  
**Spitfire Mk.IX cockpit**  
1/48 Eduard

648099  
**Spitfire exhaust  
stacks fishtail**  
1/48 Eduard



648098  
**Spitfire wheels  
- 5 spoke**  
1/48 Eduard

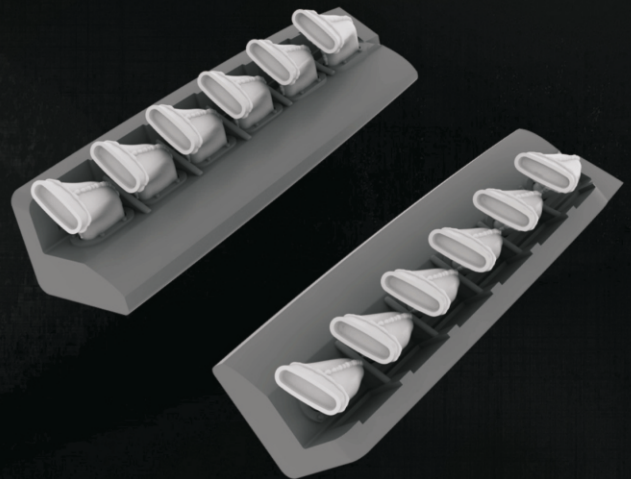

648113  
**Spitfire Mk.IX gun bay**  
1/48 Eduard

648112  
**Spitfire Mk.IX engine**  
1/48 Eduard

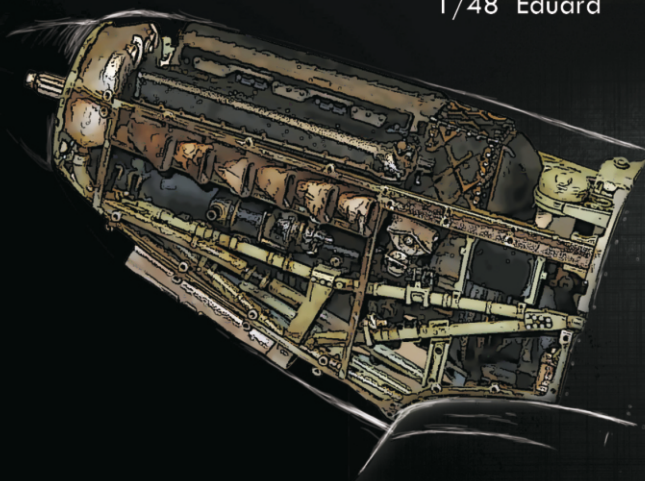

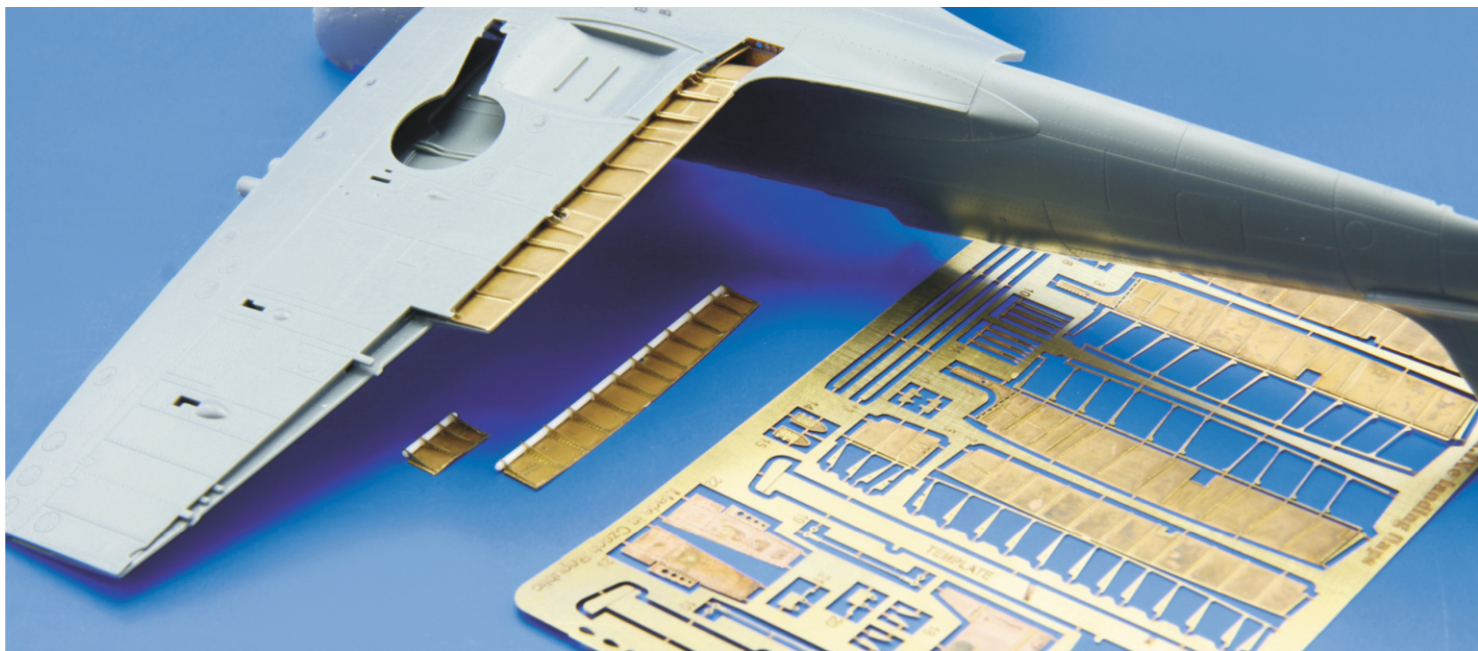

48765  
**Spitfire Mk.IXc  
 landing flaps**  
 1/48 Eduard

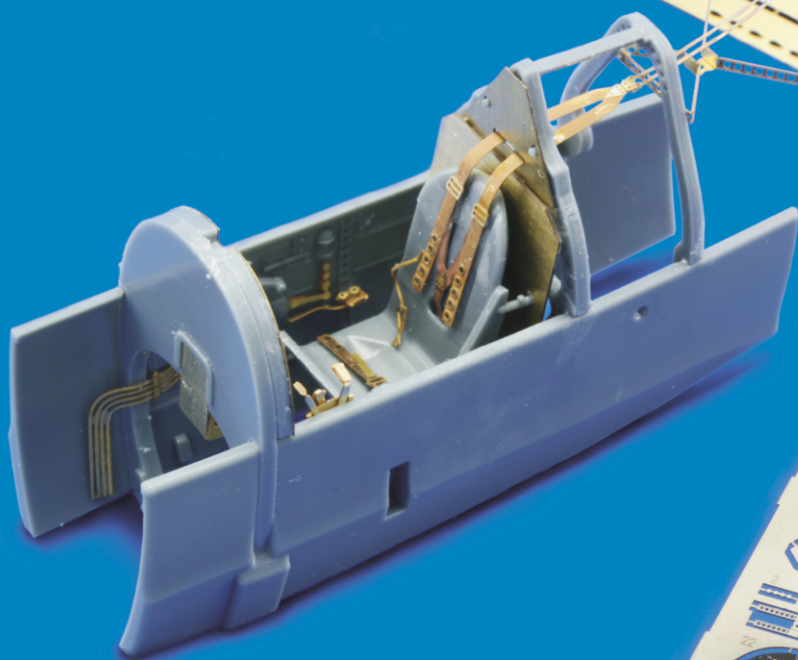

49639  
**Spitfire Mk.IXc**  
 1/48 Eduard

48766  
**Spitfire Mk.IX  
 surface panels**  
 1/48 Eduard

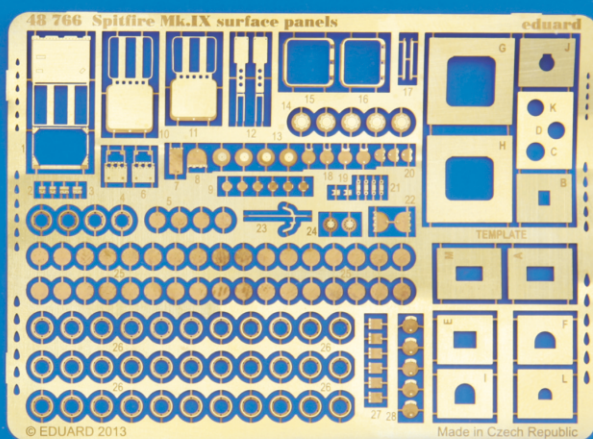
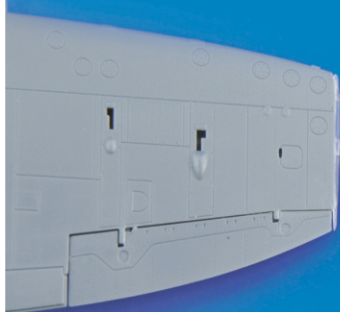
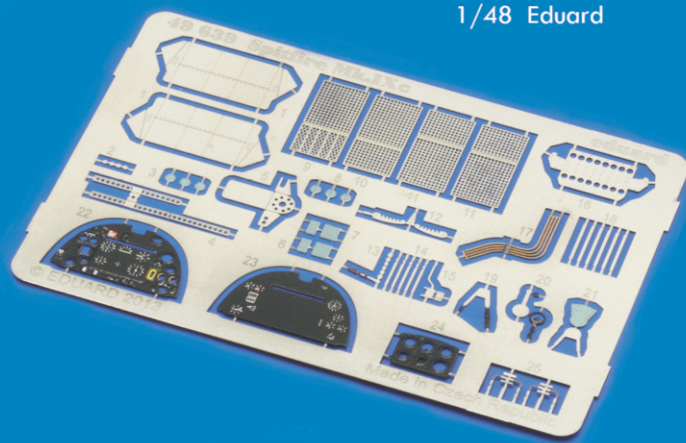

D48015  
**Spitfire stencils**  
 1/48

49062  
**Seatbelts RAF  
 WWII FABRIC**  
 1/48