

PLASTIC PARTS

B>

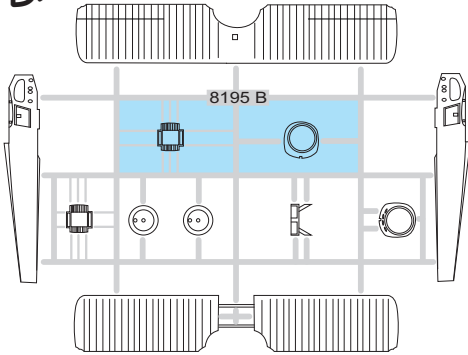

C>

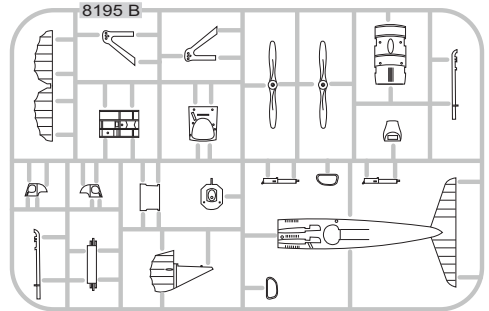

D>

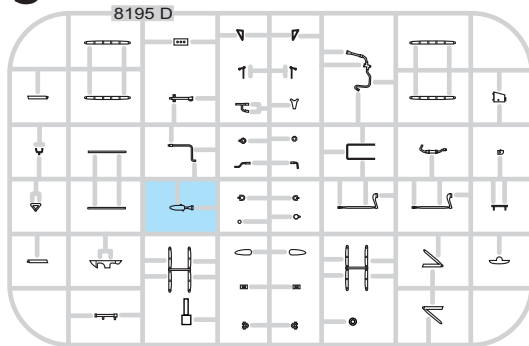

E>

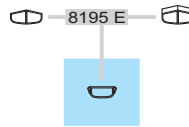

Mr. COLOR	
C5	BLUE
C11	LIGHT GRAY
C13	NEUTRAL GRAY
C17	DARK GREEN
C22	DARK EARTH
C33	FLAT BLACK
C41	RED BROWN
C43	WOOD BROWN
C45	SAIL COLOR
C62	FLAT BLACK
C81	RUSSET
C119	SAND YELLOW
C137	TIRE BLACK
C303	GREEN

AQUEOUS	
H77	TIRE BLACK

Mr. METAL COLOR	
MC214	DARK IRON
MC218	ALUMINIUM
MC219	BRASS

■ Parts not for use. -Teile werden nicht verwendet. -Pièces à ne pas utiliser. -Tylo dily nepouzivajte při stavbě. - 使用しない部品

ATTENTION * UPOZORNĚNÍ * ACHTUNG * ATTENTION

(GB)

Carefully read instruction sheet before assembling. When you use glue or paint, do not use near open flame and use in well ventilated room. Keep out of reach of small children. Children must not be allowed to suck any part, or pull vinyl bag over the head.

(CZ)

Před začočetím stavby si pečlivě prostudujte stavební návod. Při používání barev a lepidel pracujte v dobře větrané místnosti. Lepidla ani barvy nepoužívejte v blízkosti otevřeného ohně. Model není určen malým dětem, mohlo by dojít k požití drobných dílů.

(D)

Von dem Zusammensetzen die Bauanleitung gut durchlesen. Kleber und Farbe nicht nahe von offenem Feuer verwenden und das Fenster von Zeit zu Zeit Belüftung öffnen. Bausatz von kleinen Kindern fernhalten. Verhüten Sie, daß Kinder irgendwelche Bauteile in den Mund nehmen oder Plastiktüten über den Kopf ziehen.

(F)

lire soigneusement la fiche d' instructions avant d' assembler. Ne pas utiliser de colle ou de peinture à proximité d' une flamme nue, et aérer la piece de temps en temps. Garder hors de portée des enfants en bas âge. Ne pas laisser les enfants mettre en bouche ou sucer les pièces, ou passer un sachet vinyl sur la tête.

INSTRUCTION SIGNS * INSTR. SYMBOLY * INSTRUKTION SINNBILDEN * SYMBOLES

 OPTIONAL
 VOLBA

 BEND
 OHNOUT

 OPEN HOLE
 VYVRTAT OTVOR

 SYMETRICAL ASSEMBLY
 SYMETRICKÁ MONTÁŽ

 REMOVE
 ODŘÍZNOUT

 REVERSE SIDE
 OTOČIT

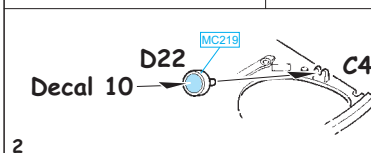
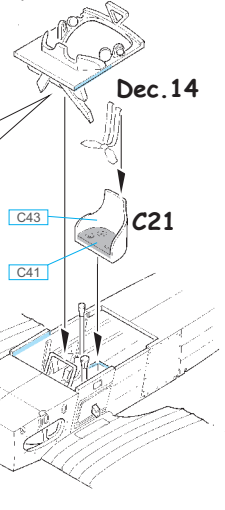
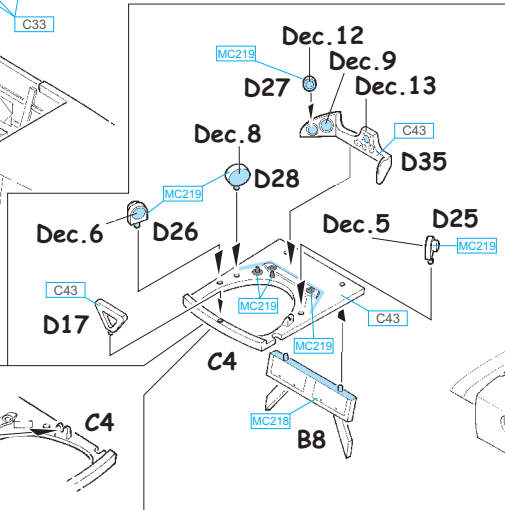
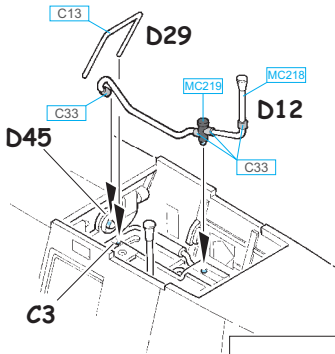
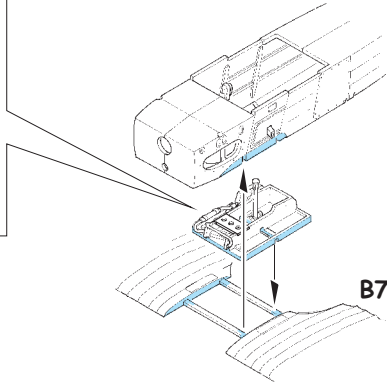
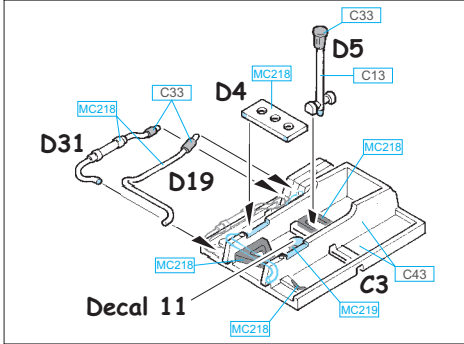
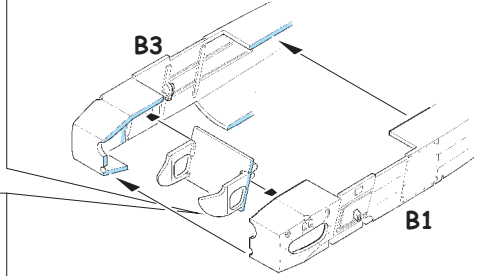
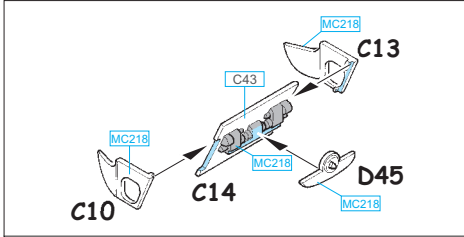
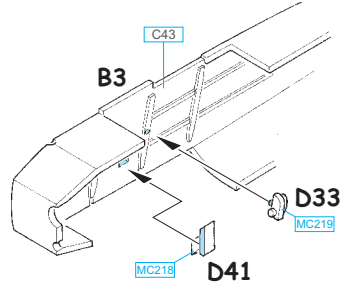
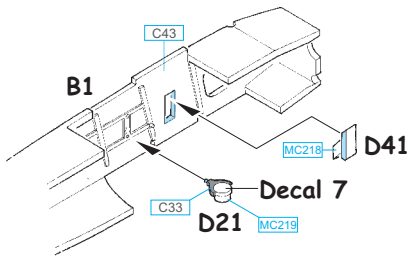

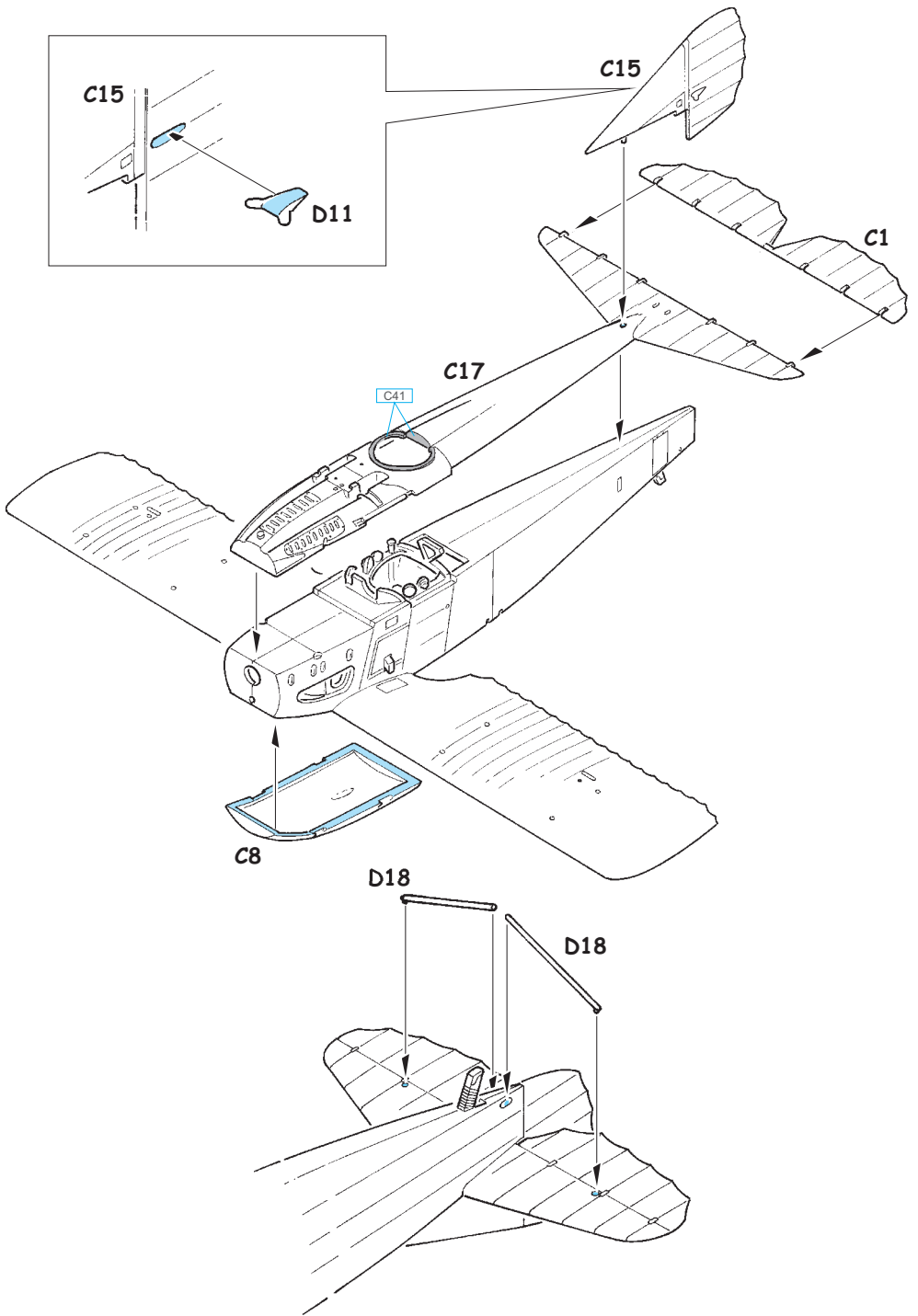

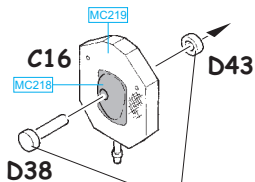

DO NOT GLUE!
NELEPIT!

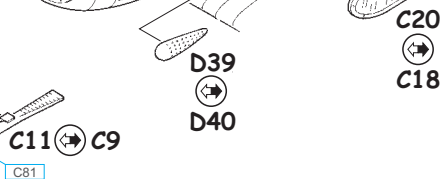
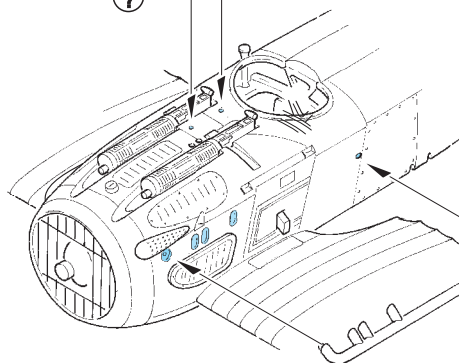
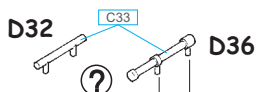
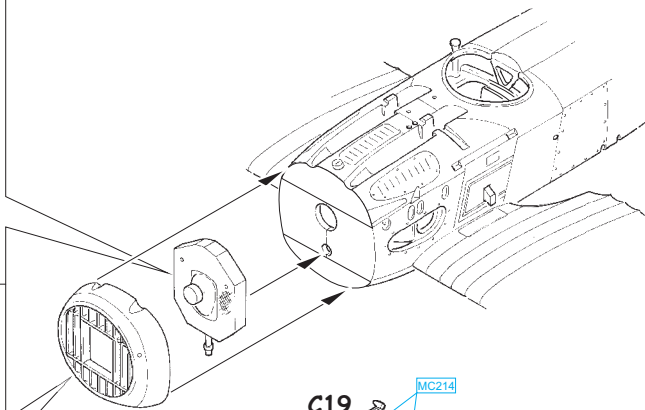
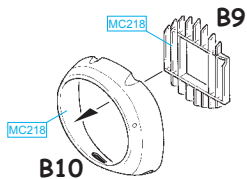

MARKING B

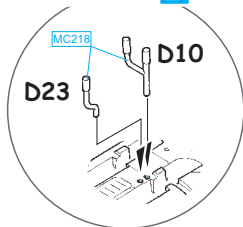

MARKING A

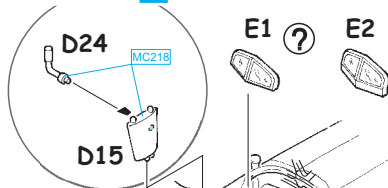

E1 - MARKING A
E2 - MARKING B

