

# A c/n 2015337, US Air Force & US Navy, 1953 - 1956

The desire of the American armed forces to obtain the airworthy MiG-15 lead to announcing the 100 000 USD reward and political asylum promise for the pilot delivering MiG-15 to them. On September 21st, 1953 Lt. No Kum Suk took off from his airbase with this MiG-15bis and landed at Kimpo airbase where he handed it over to the Americans. Supposedly he was not aware of the reward. The American technicians dismantled the airframe and transported it to the Kadena airbase on Okinawa where it went through first stage of tests. The further examinations followed at the airbases Wright-Patterson in Ohio and Eglin in Florida. After that the aircraft was handed over to the Navy who tested it at Patuxent River airbase in Maryland. In April 1956 the airplane was written off after a hard landing at Wright-Patterson while tested by British pilots. During the testing the North Korean marking was removed and the aircraft received American national insignia and marking which changed in the course of testing. Initially the airplane carried the numeral 616, later the letters TC were added including the insignia of the unit where the tests were performed.

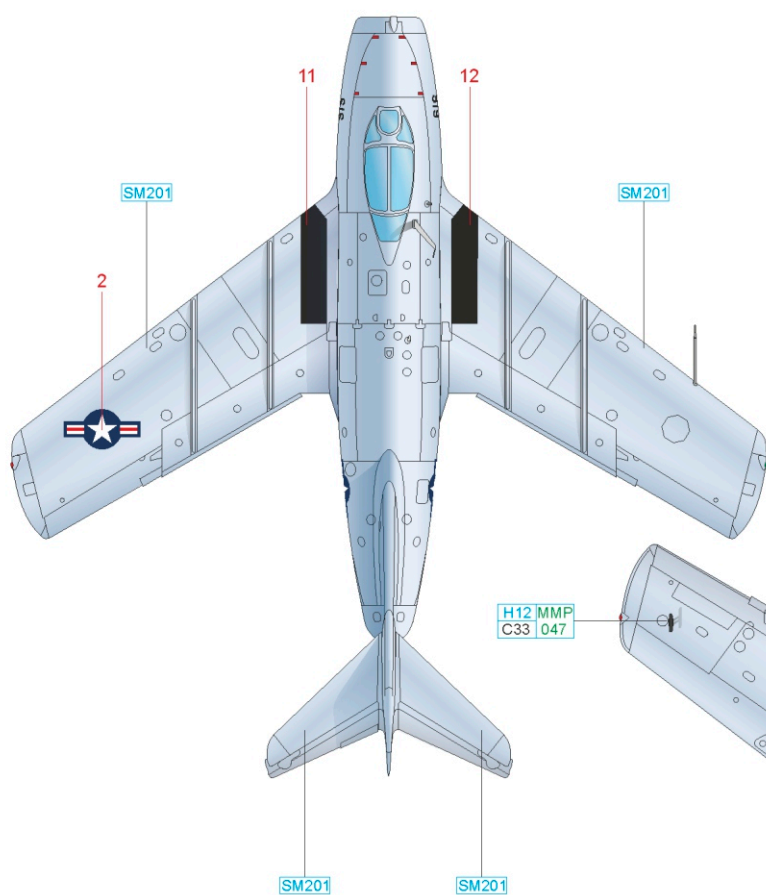

ČESKOU VERZI TEXTU NALEZNETE NA  
[www.eduard.com](http://www.eduard.com)  
POD KATALOGOVÝM ČÍSLEM BFC093

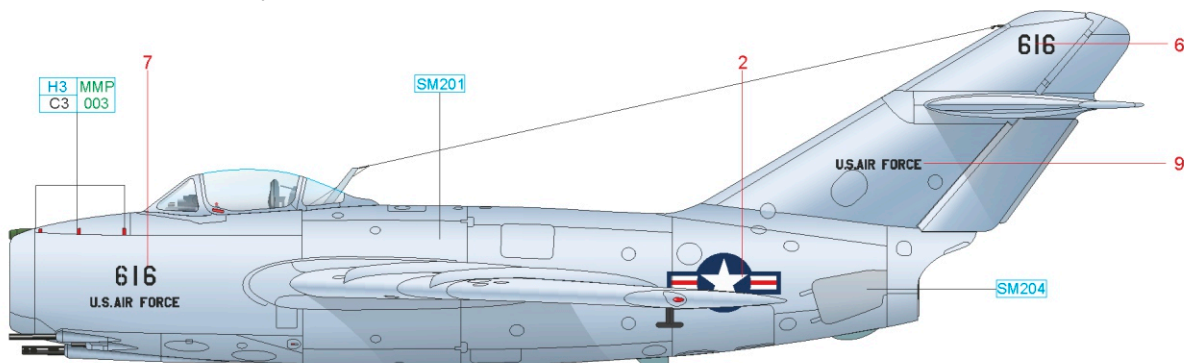
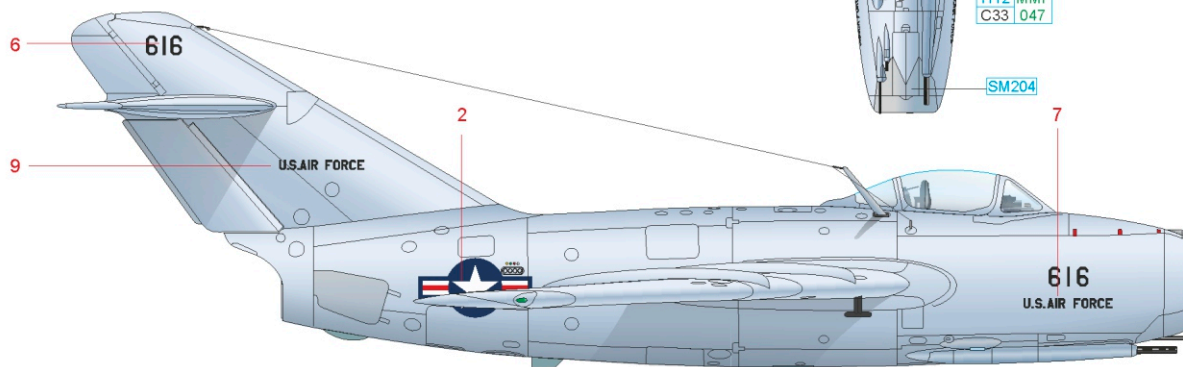
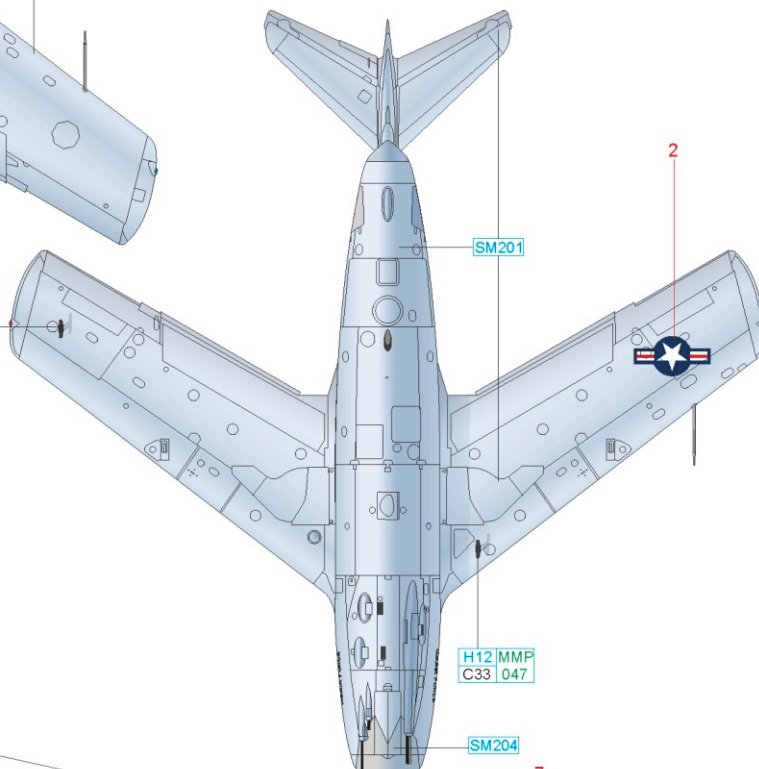

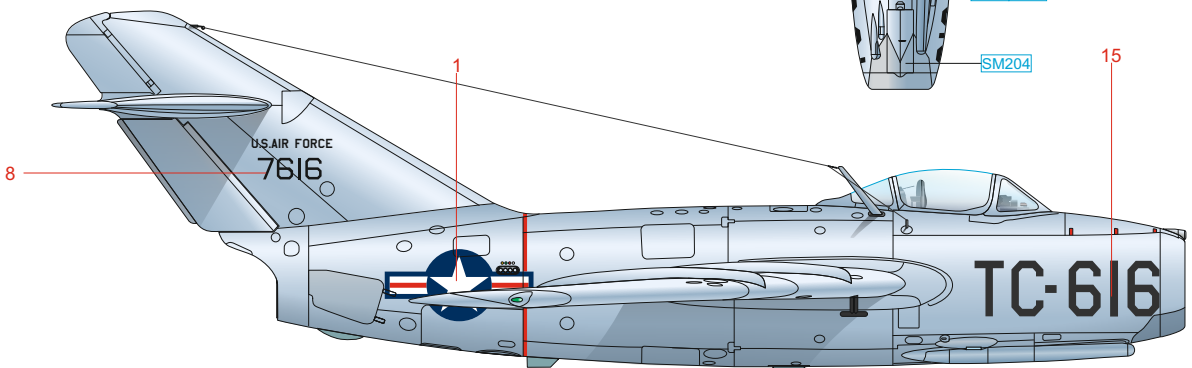
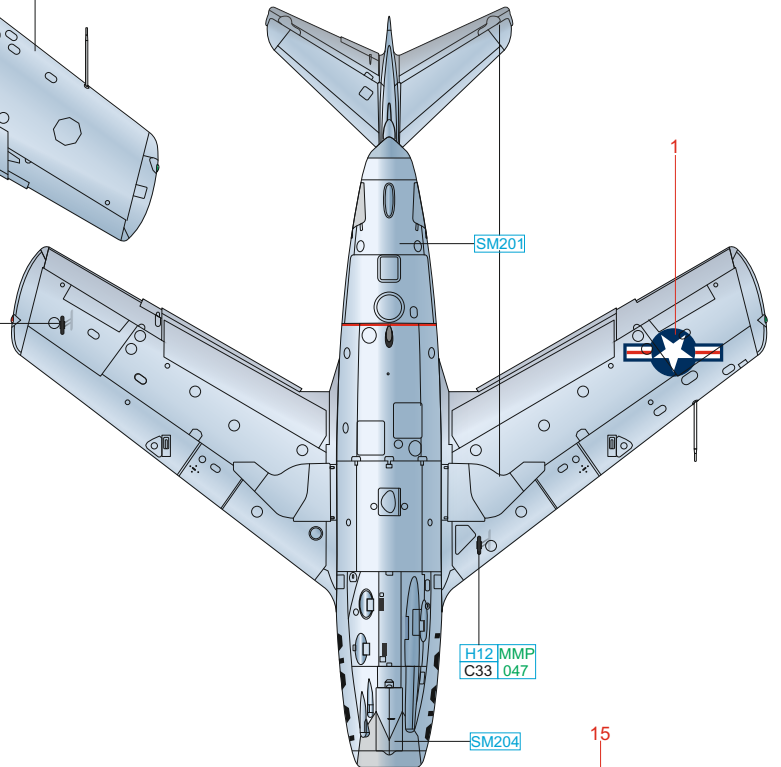
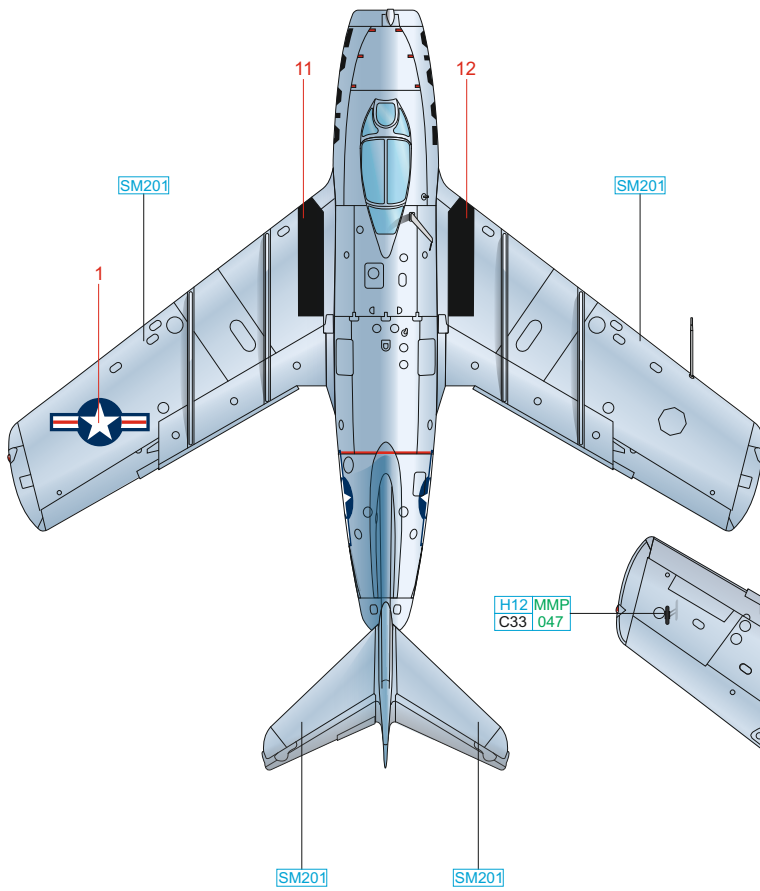
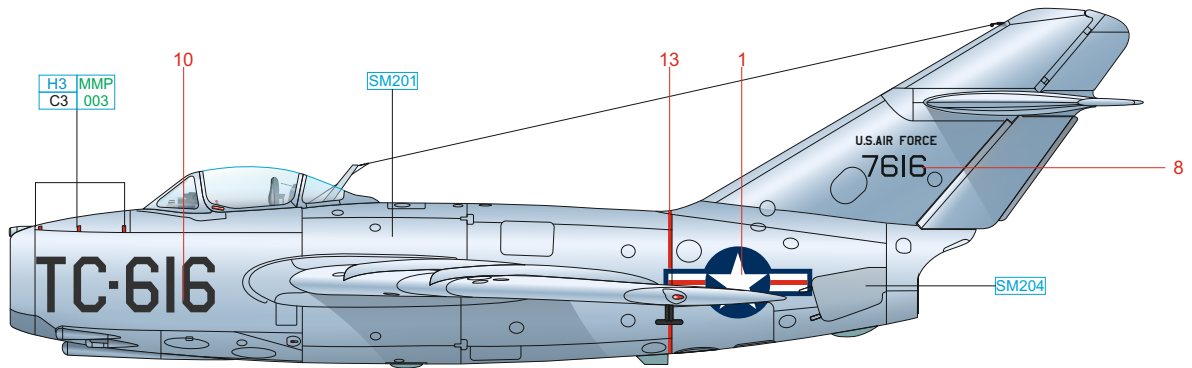

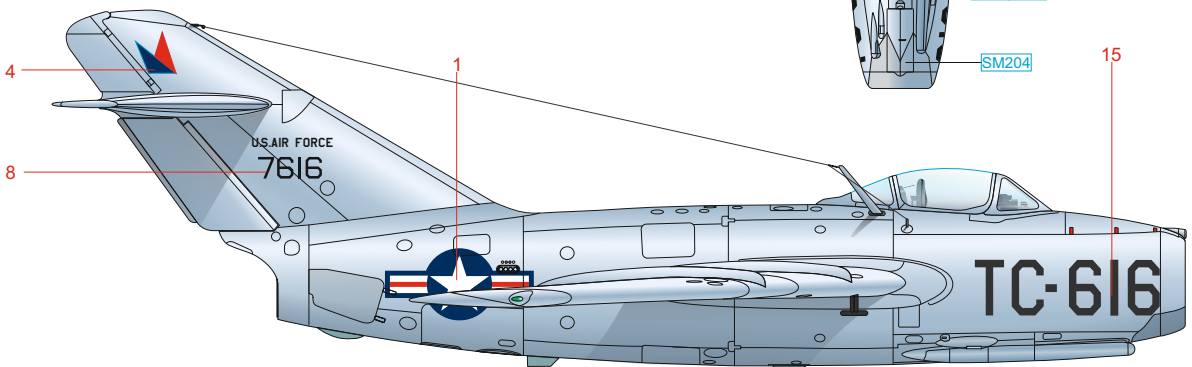
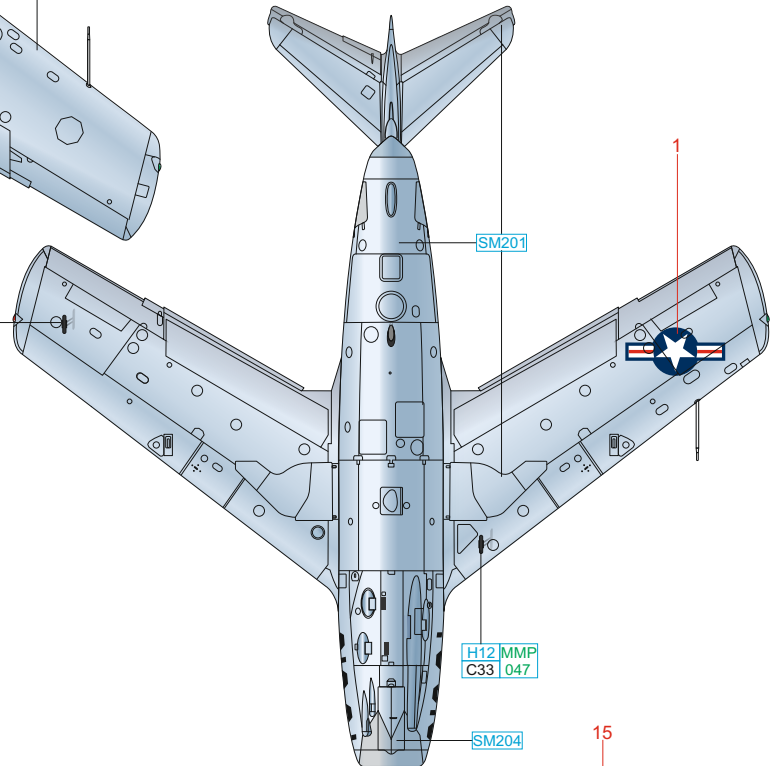
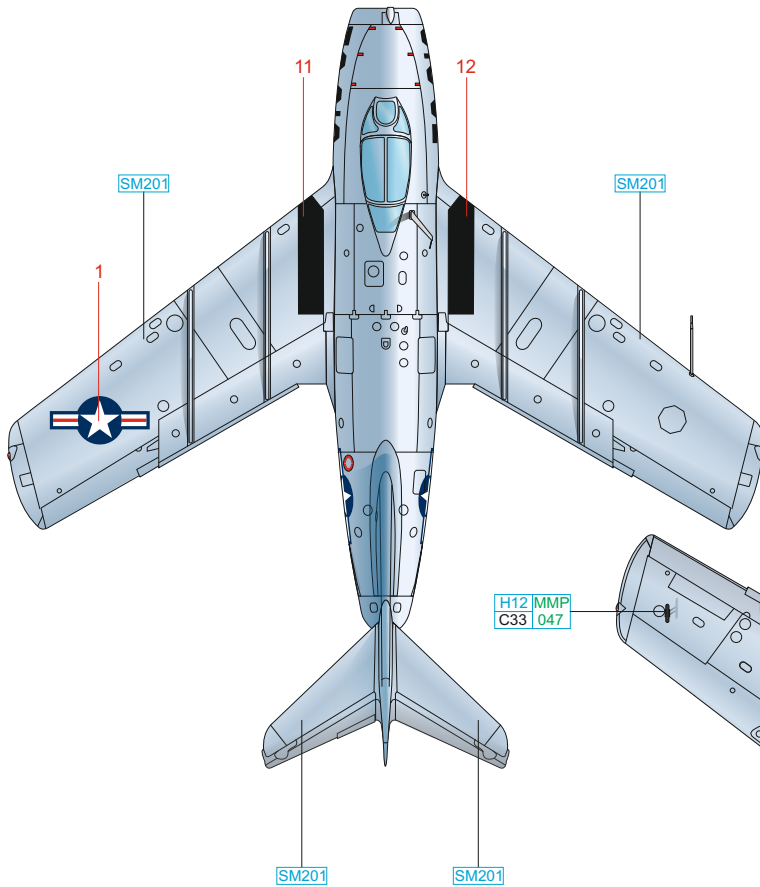
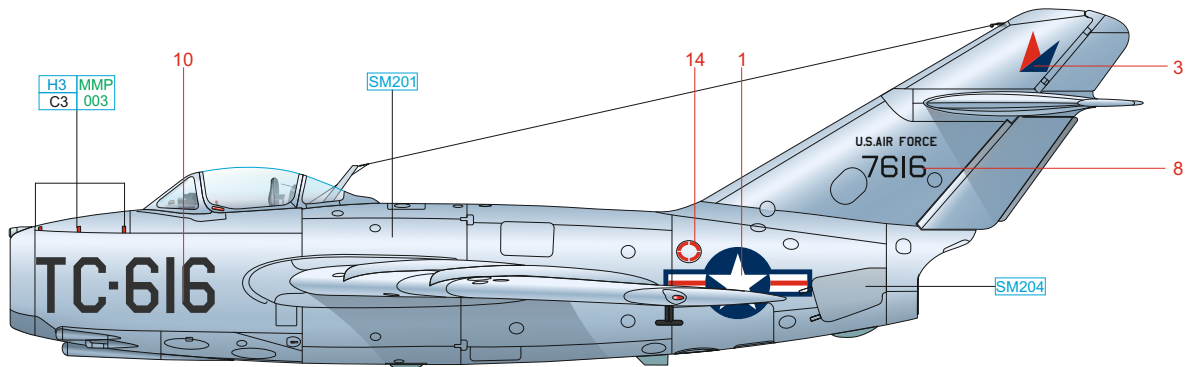

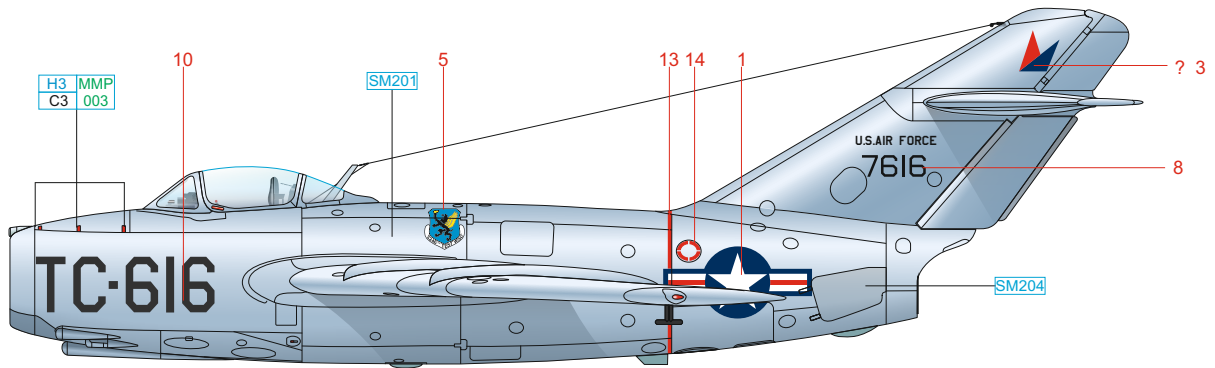

H3 MMP  
C3 003

SM201

SM204

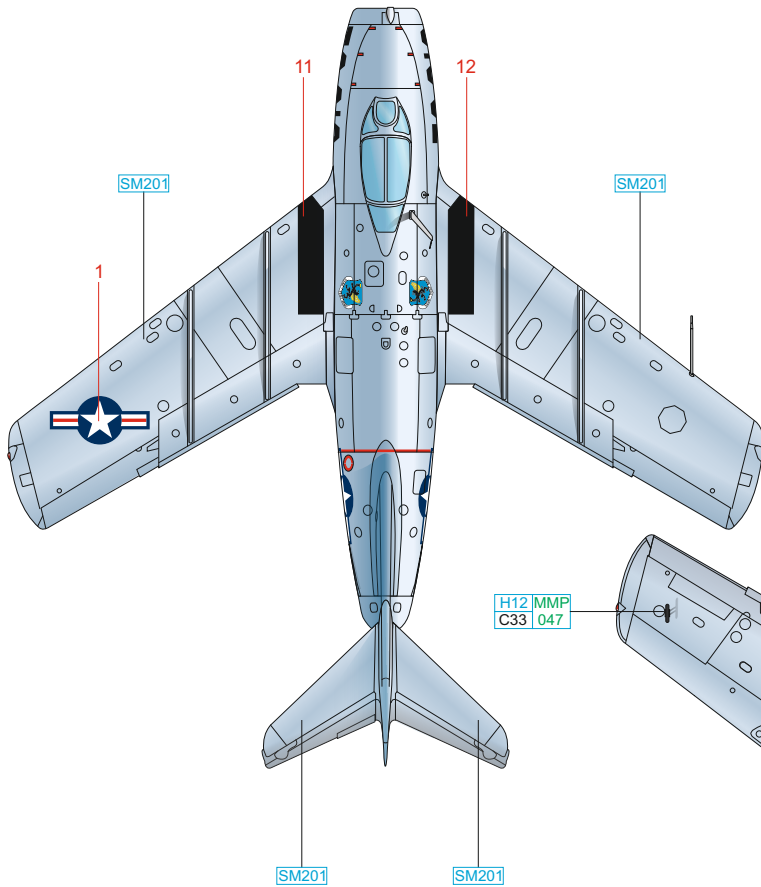

SM201

SM201

H12 MMP  
C33 047

SM201

SM201

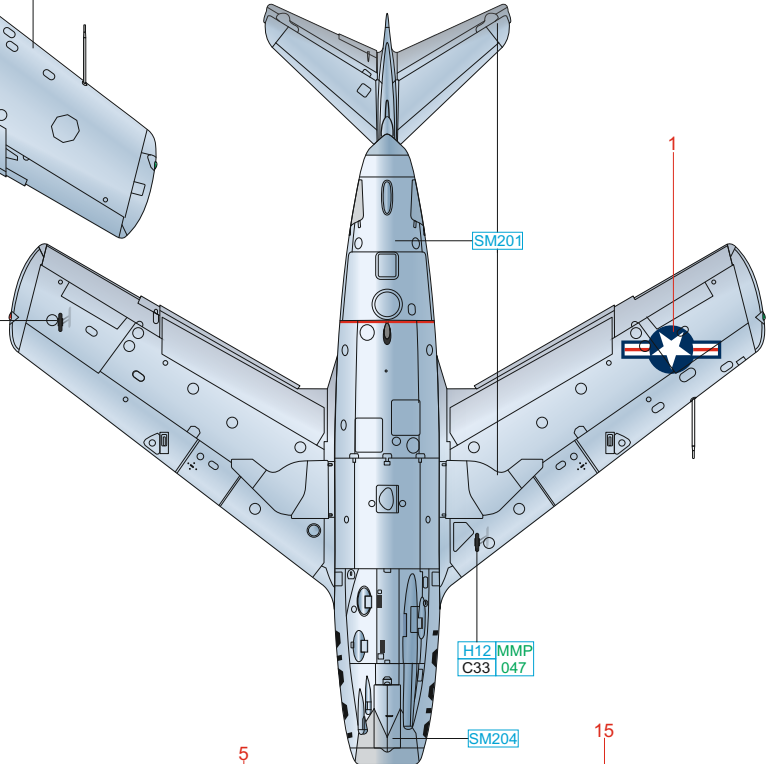

SM201

H12 MMP  
C33 047

SM204

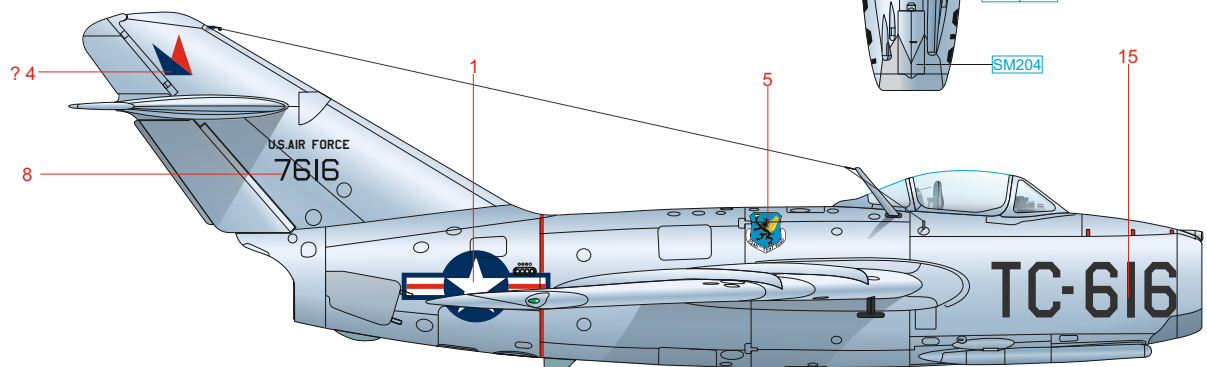

? 4

8

1

5

15

SM204

RED H3 MMP C3 003 BLACK H12 MMP C33 047 SUPER STAINLESS SM204 SUPER FINE SILVER SM201