



DUAL COMBO!



Produced under license.
Boeing, P-51 Mustang
their distinctive logos,
product markings and
trade dress are trademarks
of The Boeing Company.



INTRO

Designed in 1940, in service until 1984... The life of one of the most famous fighter plane of all time is very long and successful story initiated by the request from the British Buying Committee during 1940. While Germans were marching through the Europe, all the British plants were running at full speed to produce fighters and bombers in preparations for the inevitable clash. The RAF had its Spitfires and Hurricanes but did not want to waste them for strafing or reconnaissance purposes. So the source of suitable aircraft was sought elsewhere. USA had the capacity and technological level for such a supply, but only Bell P-39 Airacobra and Curtiss P-40 Tomahawk were found by RAF satisfactory, although far from perfect. More to it, the Curtiss had no capacity to build P-40s for RAF, so the North American Aviation (NAA) was approached by Britons with request to do so. But NAA president James Kindelberger offered development of completely new plane instead. After the preliminary work by design team led by chief designer Edgar Schmued, who was German born Austrian, the Britons agreed. The preliminary design was approved on May 4th, 1940, final assembly and engine installation began on September 9th (just 127 days after approval) and the first flight of the NA-73X prototype followed on October 26th. The plane incorporated numerous novelties, like the laminar flow airfoil, but the engine used (Allison V-1710-39 V12) had only one stage compressor supercharging, limiting the effective use of the new plane to low and mid levels. RAF chose the Mustang name for the new type (which the US Army Air Corps adopted) and received its first Mk.I.s in October 1941. The performance was found satisfactory, as the Mustang was faster than the Spitfire Mk.V and had more than double the range.

Several Allison powered P-51 Mustang variants were developed, even the dive bomber A-36, and they were considered a very good design, apart of aforementioned altitude limitations. To expand its versatility, the work began in Britain to fit the turbocharged Merlin engine into the Mustang Mk.I. The trials of the prototype were promising and both RAF as well as USAAF were interested. As there was no capacity for additional Merlin production in the UK, the Packard, company already building the Merlins under license, was approached and the NAA team started to design Merlin powered Mustang. For even more range, 85 gallon tank was installed behind the pilot's seat. The production started at the Inglewood plant as P-51B on May and the new production line at NAA Dallas plant started to make P-51C in August 1943. Also the supplies to RAF continued as Mustang Mk.III.

Das "Definitive"

The P-51B/C were great fighters but lacked backward visibility and suffered with gun jamming, so the design team of NAA decided to rework the Mustang again. The main change was the bubble canopy with lowered rear fuselage. The wing was reworked to accommodate six .50 cal guns instead of just four and the new arrangement of ammo chutes eliminated the jam problem. Together with some other changes, the new P-51D (Mustang Mk.IV for RAF) was born at the end of 1943 and the production started at both Inglewood (production blocks with -NA suffix) and Dallas (-NT) plants.

The D-5 was the first production batch apart of the -1NA (100 unassembled Mustangs shipped for Australia). The 5 series retained the shape of the vertical fin from P-51B/C, but it caused problems with longitudinal stability due to the reduced rear surface area of the fuselage. Adding the dorsal fin solved the problem and factory production P-51Ds obtained it starting with P-51D-10 series, while field conversion kit was distributed to the units already using P-51D-5s. Other significant change to 10 series was new gyroscopic gunsight K-14 instead of older N-9 reflexive one. For 20 series the cover of the elevator changed from fabric to aluminium (from February 1945). During production also the battery moved from rear side of the cockpit to the nose, making room for the IFF system (Identification Friend or Foe). Starting from the 25 series the wings were fitted with attachment points for various forms of rockets and rocket launchers to add the firepower for ground attacks. There were many other, rather minor changes in production blocks, reflecting specific demands of the theatre or use. For example the recon version F-6D/K and the Mustangs used in CBI (China-Barma-India) theatre were fitted with the direction finder system with distinctive ring aerial. On the other hand, the P-51K Mustang was essentially a P-51D with a different propeller (Aeroproduct instead of Hamilton Standard). Only Dallas factory produced the K variant. The RAF variant of P-51K was marked Mk.IVa.

Luftwaffe killers and Tokyo Club

The P-51D became the true ruler of the skies wherever it appeared, serving as the escort and patrol fighter, and also in ground attack or reconnaissance role (F-6 variants). One of the most significant tasks of P-51D (production blocks 20 and 25) were very long range raids to the Tokyo, conducted by the 15th, 26th and 506th Fighting Groups of 7th Fighter Command (The Sunsetters). Full of fuel and ammo, with big drop tanks the P-51s took off from Iwo Jima, flew some 1300 miles over the sea to attack heavily defended ground targets in the vicinity of the Tokyo. The pilots stayed in cockpit for some eight hours and doing this at least once earned one the membership to the so called „Tokyo Club“. In European theatre, the mighty 8th, 9th and 15th Air Force produced numerous aces with George J. Preddy Jr. being the highest scorer of all the P-51 pilots with 23,83 kills.

In total, 8,102 P-51Ds and 1,500 of P-51Ks were produced. Many of them stayed operational after the WWII and served in pursuit and attack role even during the Korean War. The last P-51 retired from USAF service in 1978. RAF retired its Mustangs in 1947, as the P-51 was a Lend-Lease type and all the aircraft still on charge with RAF at the end of the WWII were to be returned or scrapped. In foreign services the Mustang stayed operational until 1984 (Dominican Republic). Edgar Schmued, the force behind the development of P-51, passed away just a year later. Some 55 nations used his Mustang during 43 years.



Carefully read instruction sheet before assembling. When you use glue or paint, do not use near open flame and use in well ventilated room. Keep out of reach of small children. Children must not be allowed to suck any part, or pull vinyl bag over the head.



Před započítím stavby si pečlivě prostudujte stavební návod. Při používání barev a lepidel pracujte v dobře větrané místnosti. Lepidla ani barvy nepoužívejte v blízkosti otevřeného ohně. Model není určen malým dětem, mohlo by dojít k požití drobných dílů.

INSTRUCTION SIGNS * INSTR. SYMBOLS * INSTRUKTION SINNBILDEN * SYMBOLES * 記号の説明

- 
 OPTIONAL
VOLBA
- 
 BEND
OHNOUT
- 
 SAND
BROUSIT
- 
 OPEN HOLE
VYVRTAT OTVOR
- 
 SYMETRICAL ASSEMBLY
SYMETRICKÁ MONTÁŽ
- 
 REMOVE
ODŘÍZNOUT
- 
 REVERSE SIDE
OTOČIT
- 
 APPLY EDUARD MASK
AND PAINT
POUŽIT EDUARD MASK
NABARVIT

PARTS * DÍLY * TEILE * PIĘCES * 部品

PLASTIC PARTS

A> 2 pcs.

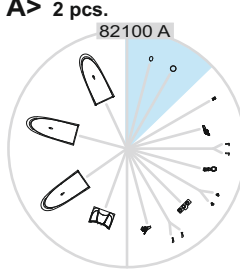

B> 2 pcs.

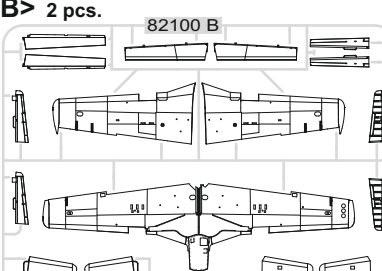

C>

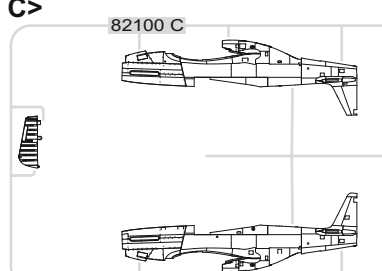

D> 2 pcs.

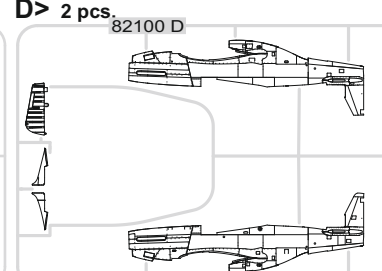

F> 2 pcs.

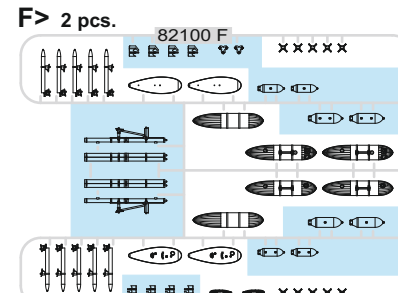

G> 2 pcs.

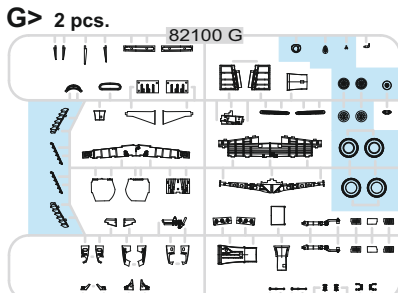

H> 2 pcs.

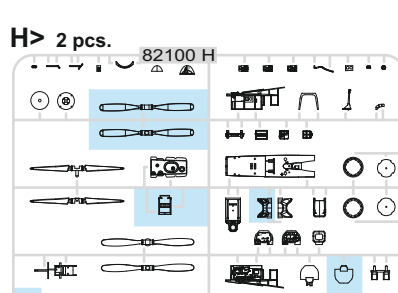

J>

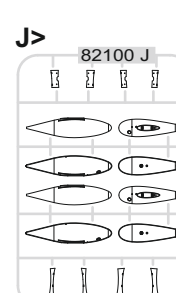

RP - RESIN PARTS

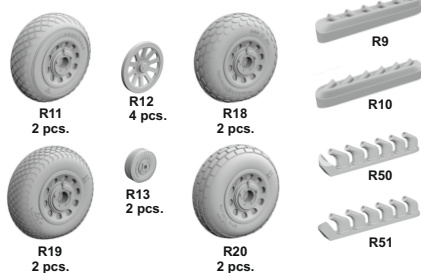

PE - PHOTO ETCHED DETAIL PARTS

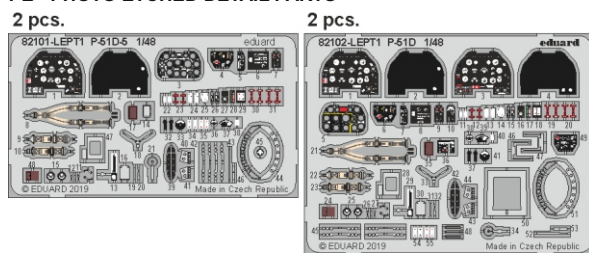

eduard MASK

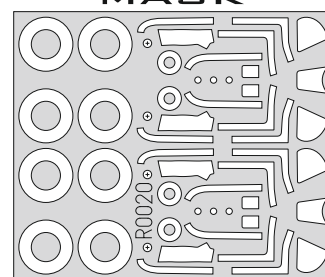

-Parts not for use. -Teile werden nicht verwendet. -Pièces à ne pas utiliser. -Tyto díly nepoužívejte při stavbě. - 使用しない部品

COLOURS * BARVY * FARBEN * PEINTURE * 色

| GSI Creos (GUNZE) | | MISSION MODELS | |
|-------------------|----------|----------------|----------------|
| AQUEOUS | Mr.COLOR | PAINTS | |
| H1 | C1 | MMP-001 | WHITE |
| H4 | C4 | MMP-007 | YELLOW |
| H6 | C6 | MMP-004 | GREEN |
| H8 | C8 | | SILVER |
| H11 | C62 | MMP-001 | FLAT WHITE |
| H12 | C33 | MMP-047 | FLAT BLACK |
| H13 | C3 | MMP-003 | FLAT RED |
| H15 | C65 | | BRIGHT BLUE |
| H25 | C34 | | SKY BLUE |
| H27 | C44 | | TAN |
| H37 | C43 | | WOOD BROWN |
| H47 | C41 | MMP-012 | RED BROWN |
| H52 | C12 | MMP-091 | OLIVE DRAB |
| H53 | C13 | | NEUTRAL GRAY |
| H58 | C351 | MMP-059 | INTERIOR GREEN |
| H77 | C137 | MMP-040 | TIRE BLACK |
| H90 | C47 | | CLEAR RED |

| GSI Creos (GUNZE) | | MISSION MODELS | |
|-------------------------|----------|----------------|---------------------|
| AQUEOUS | Mr.COLOR | PAINTS | |
| H91 | C48 | | CLEAR YELLOW |
| H94 | C138 | | CLEAR GREEN |
| H316 | C316 | MMP-104 | WHITE |
| H327 | C327 | MMP-101 | RED |
| H329 | C329 | | YELLOW |
| H330 | C361 | MMP-077 | GREEN |
| H335 | C363 | MMP-094 | MEDIUM SEA GRAY |
| | C135 | MMP-018 | RUSSIAN GREEN |
| | C352 | | YELLOW CHROMATE |
| | C362 | MMP-093 | OCEAN GRAY |
| Mr.METAL COLOR | | METALLICS | |
| | MC214 | MMM-001 | DARK IRON |
| Mr.COLOR SUPER METALLIC | | METALLICS | |
| | SM201 | MMC-001 | SUPER FINE SILVER 2 |
| | SM203 | | SUPER IRON 2 |
| | SM206 | MMC-001 | CHROME SILVER |

MARKINGS **A**, **B**, **C**, **D**, **E**, **M**, **N**

A 1 = 90% + 10%
C351 ZINC-CHROMATE TYPE I FLAT BLACK C33

USE PHOTOETCHED SET No. 82101

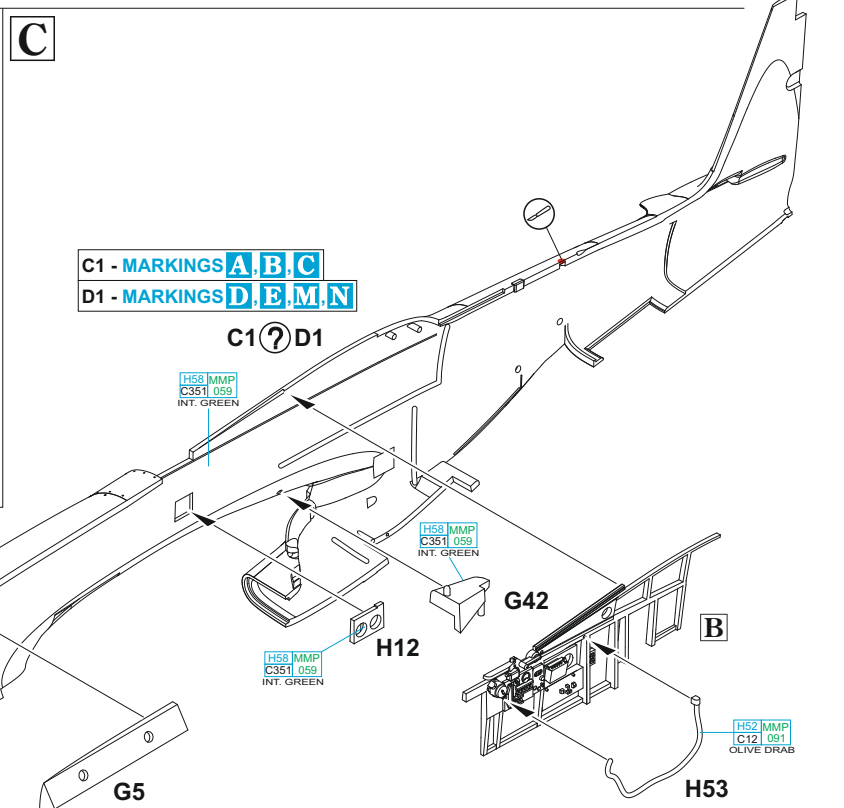
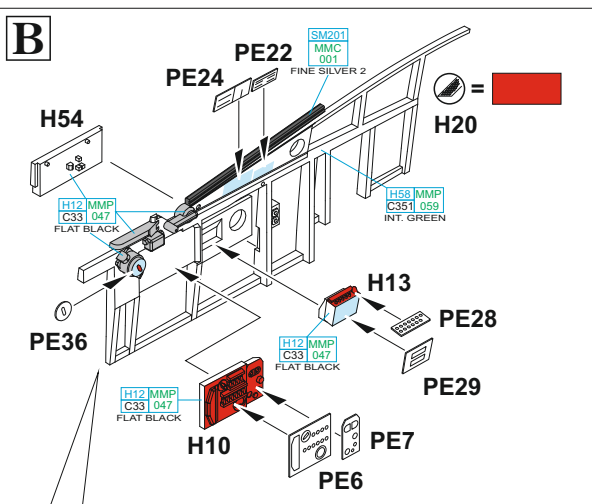
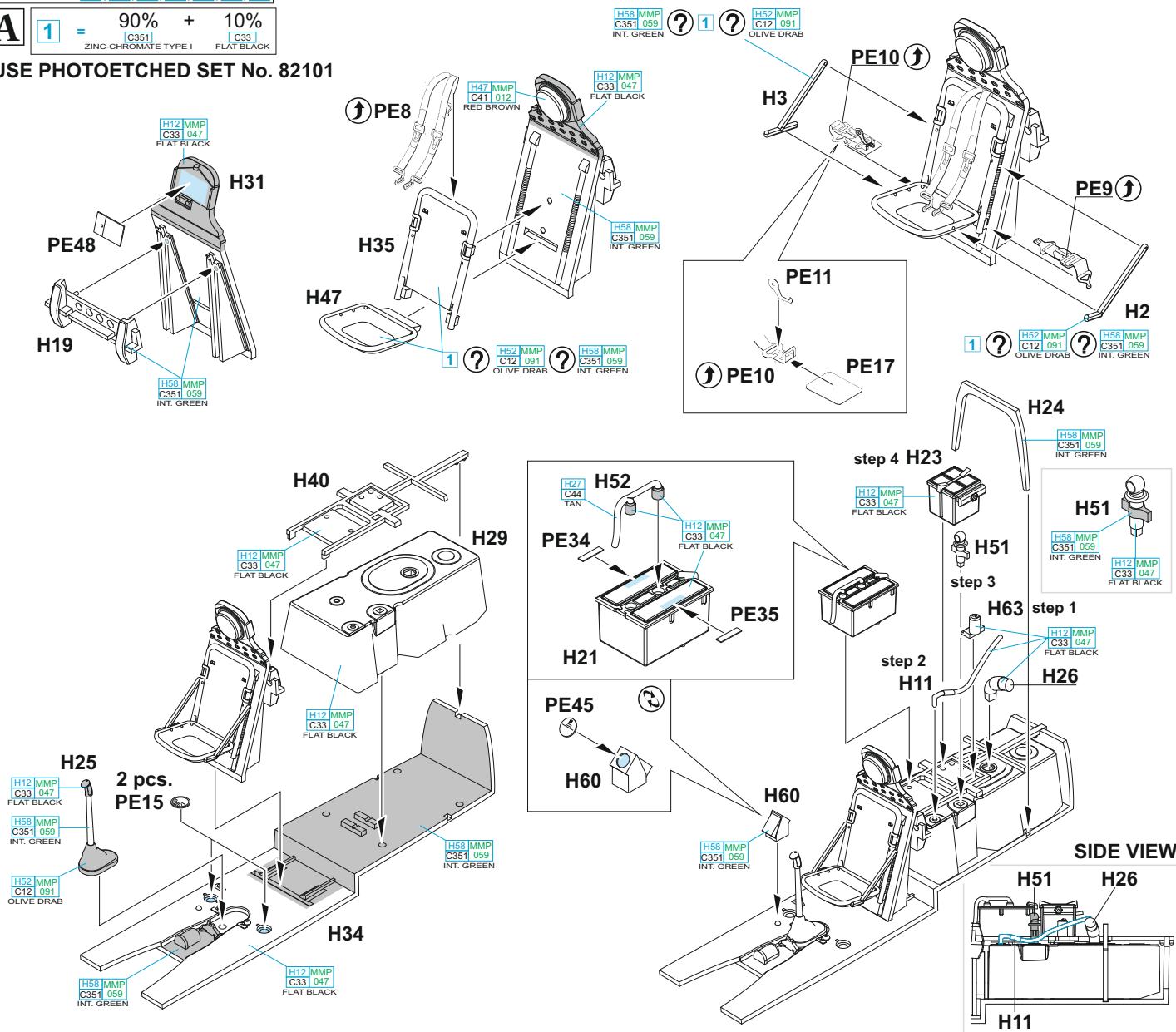

D

C2 - MARKINGS **A, B, C**
D2 - MARKINGS **D, E, M, N**

C2 ? D2

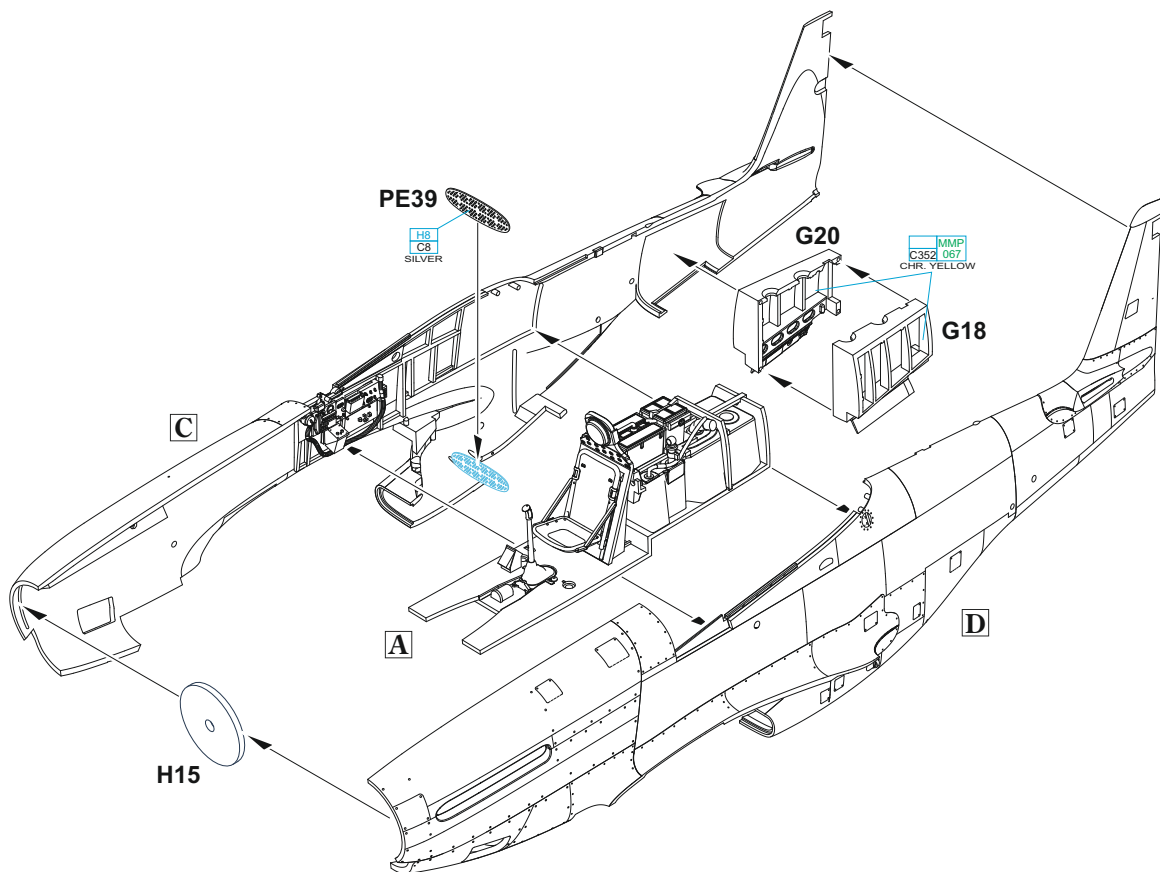
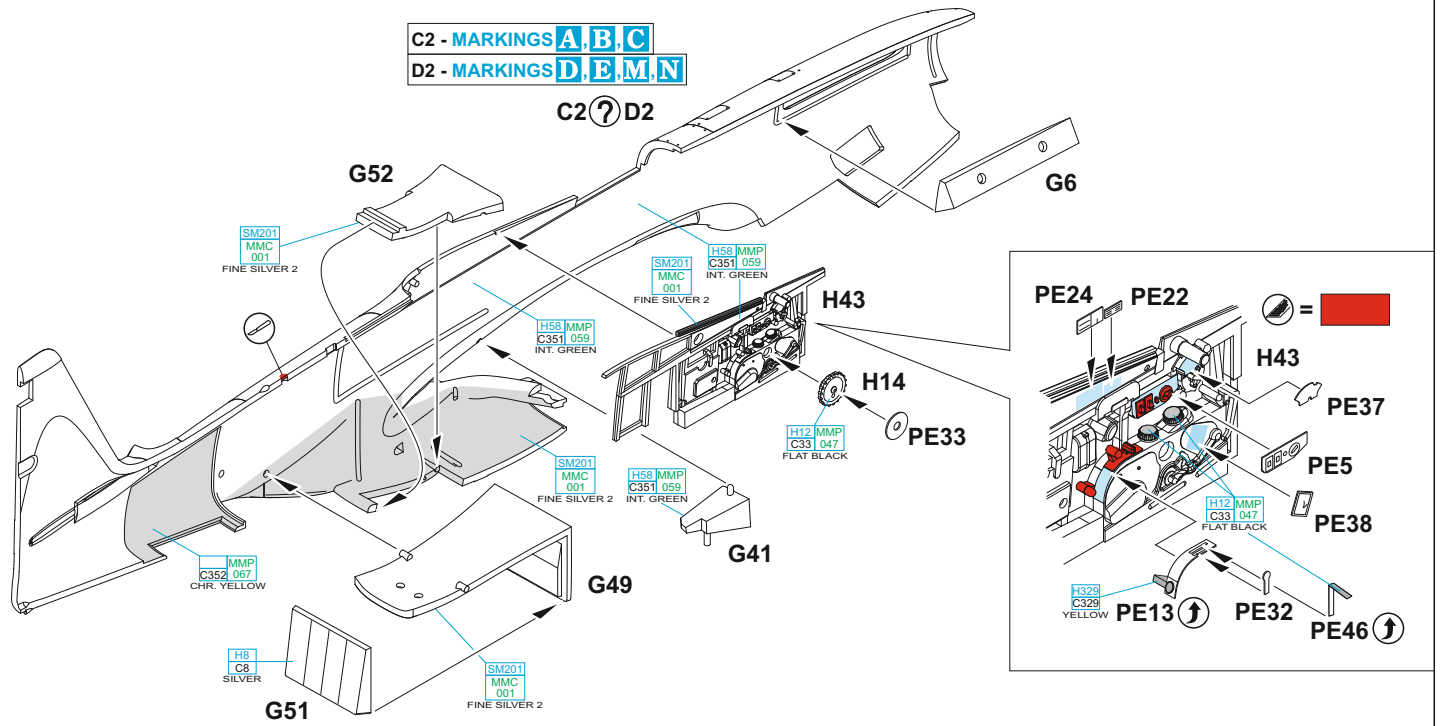

MARKINGS F, G, H, I, J, K, L

A 1 = 90% + 10%
C351 ZINC-CHROMATE TYPE I C33 FLAT BLACK

USE PHOTOETCHED SET No. 82102

H58 MMP C351 059 INT. GREEN H52 MMP C12 091 OLIVE DRAB

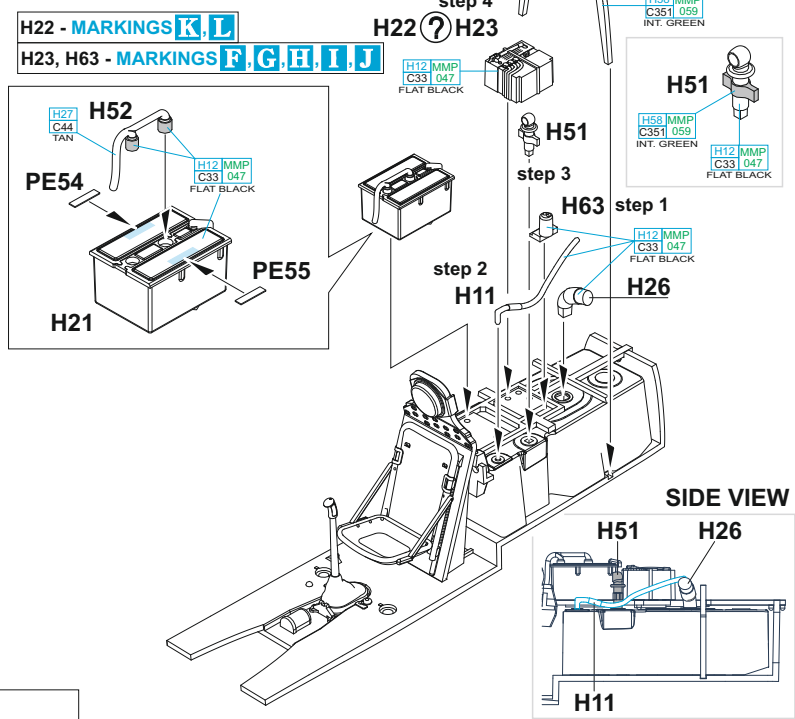
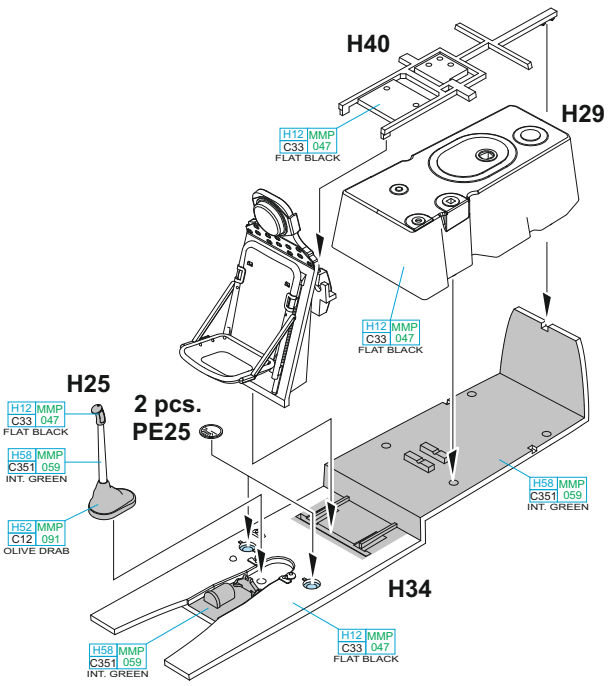
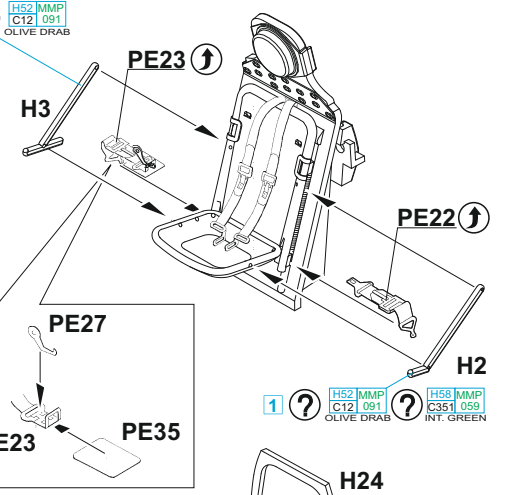
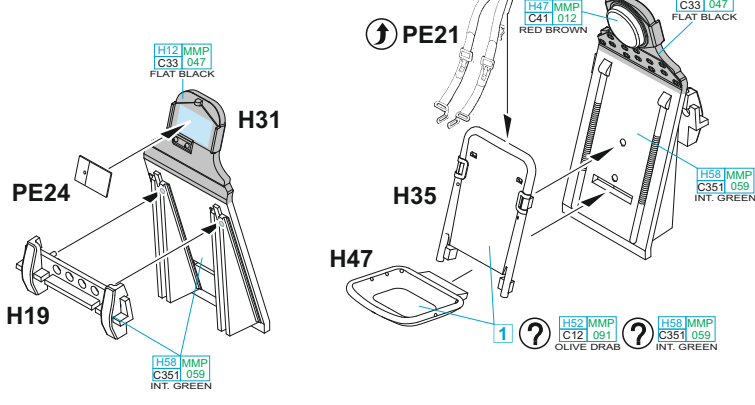

SIDE VIEW

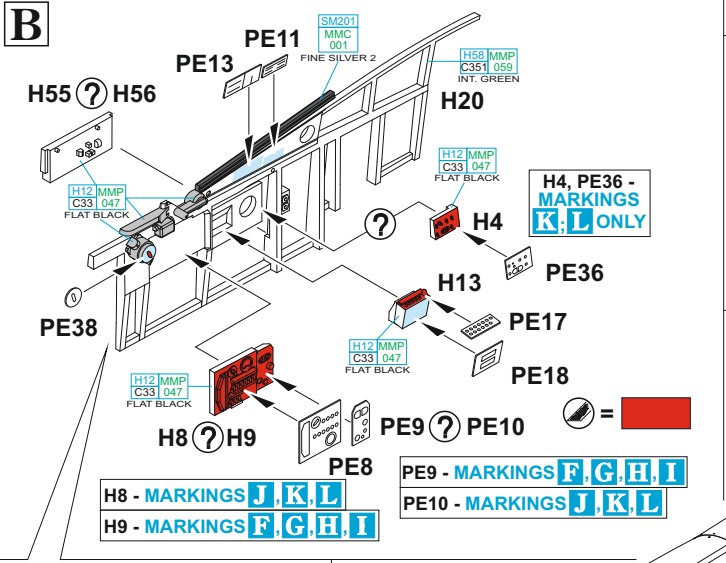
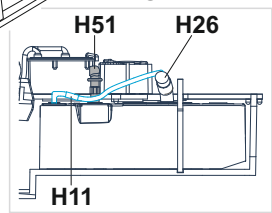

H4, PE36 - MARKINGS K, L ONLY

H8 - MARKINGS J, K, L
 H9 - MARKINGS F, G, H, I

PE9 - MARKINGS F, G, H, I
 PE10 - MARKINGS J, K, L

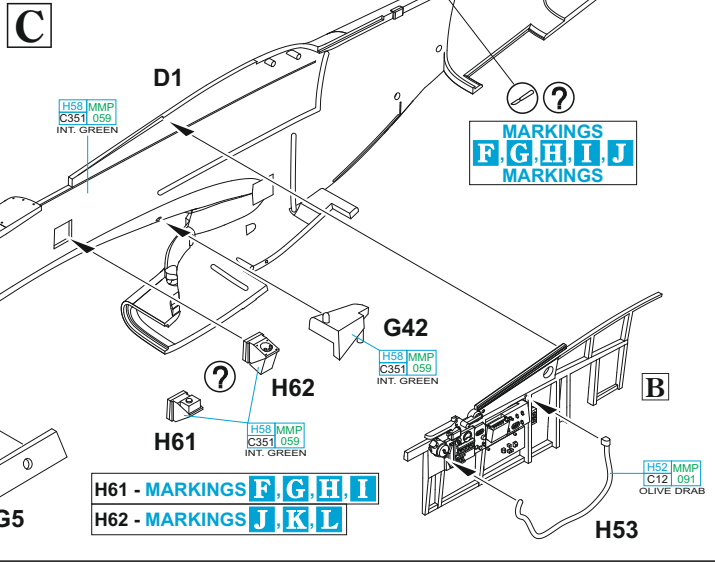
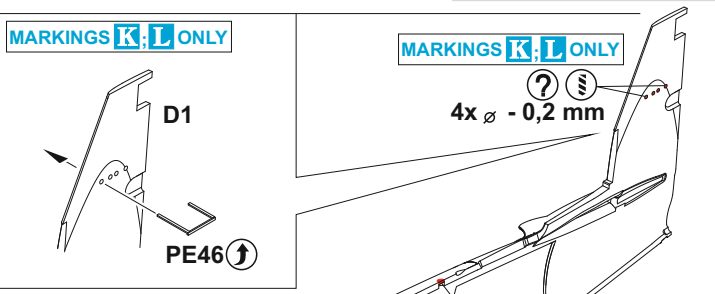

H61 - MARKINGS F, G, H, I
 H62 - MARKINGS J, K, L

MARKINGS F, G, H, I, J, K, L, MARKINGS

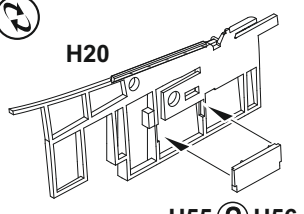

H55 - MARKINGS F, G, H, I
 H56 - MARKINGS J, K, L

D

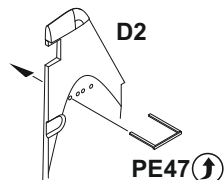

MARKINGS K, L ONLY
4x $\varnothing - 0,2$ mm

MARKINGS F, G, H, I, J
MARKINGS

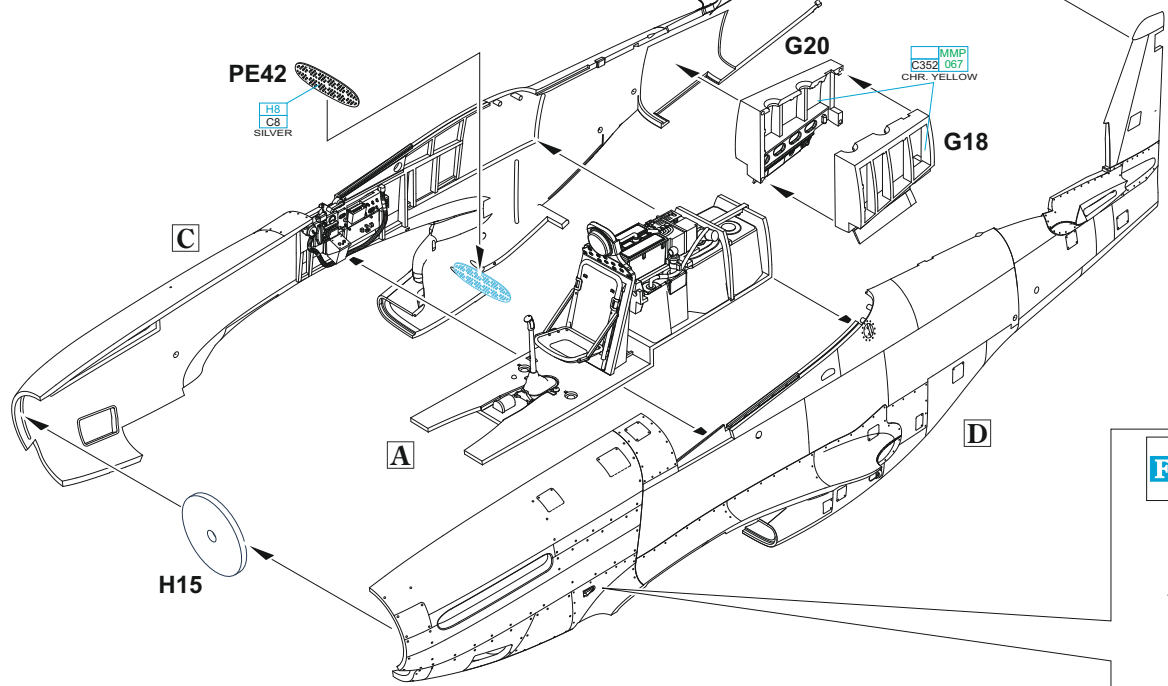
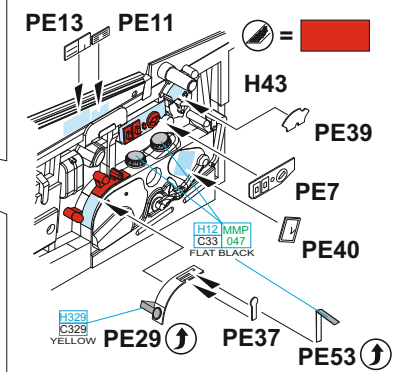
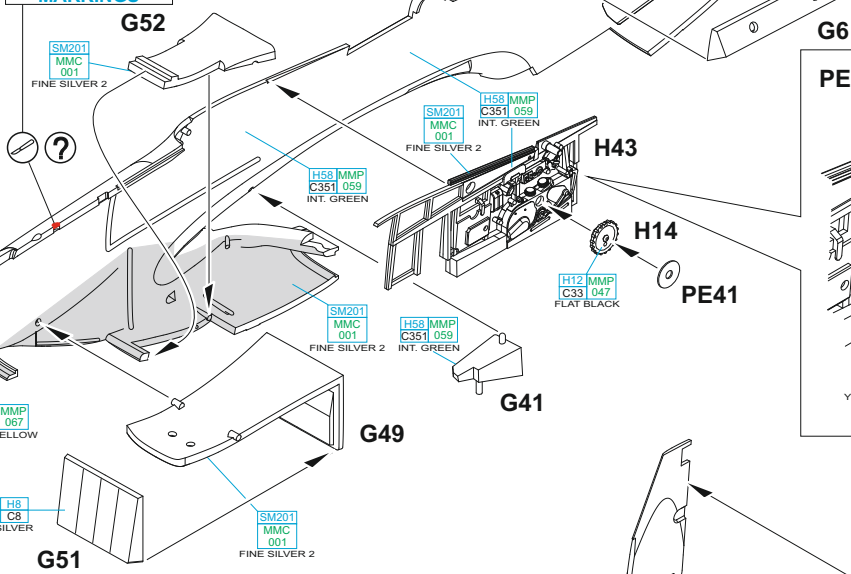

MARKINGS F, G, H, I, J
MARKINGS

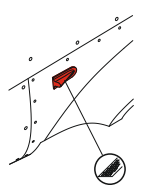

2 = **SM201 MMC 001 FINE SILVER 2** - **MARKINGS A, B, C, D, E, F, G, M, N**
MMMP C352 067 CHR. YELLOW - **MARKINGS H, I, J, K, L**

SM201 MMC 001 FINE SILVER 2 - **MARKINGS M, N ONLY**

E

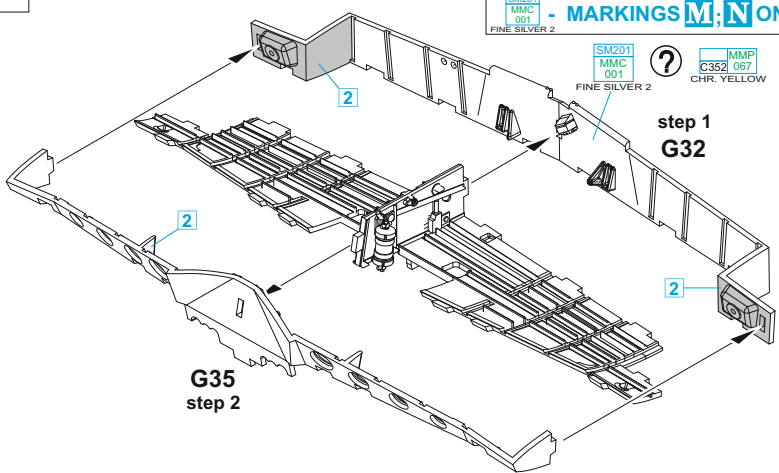
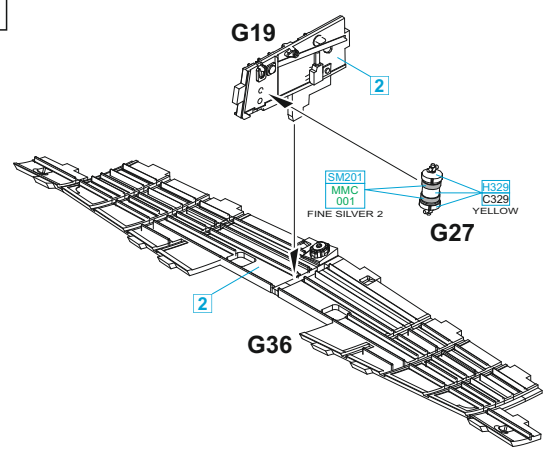

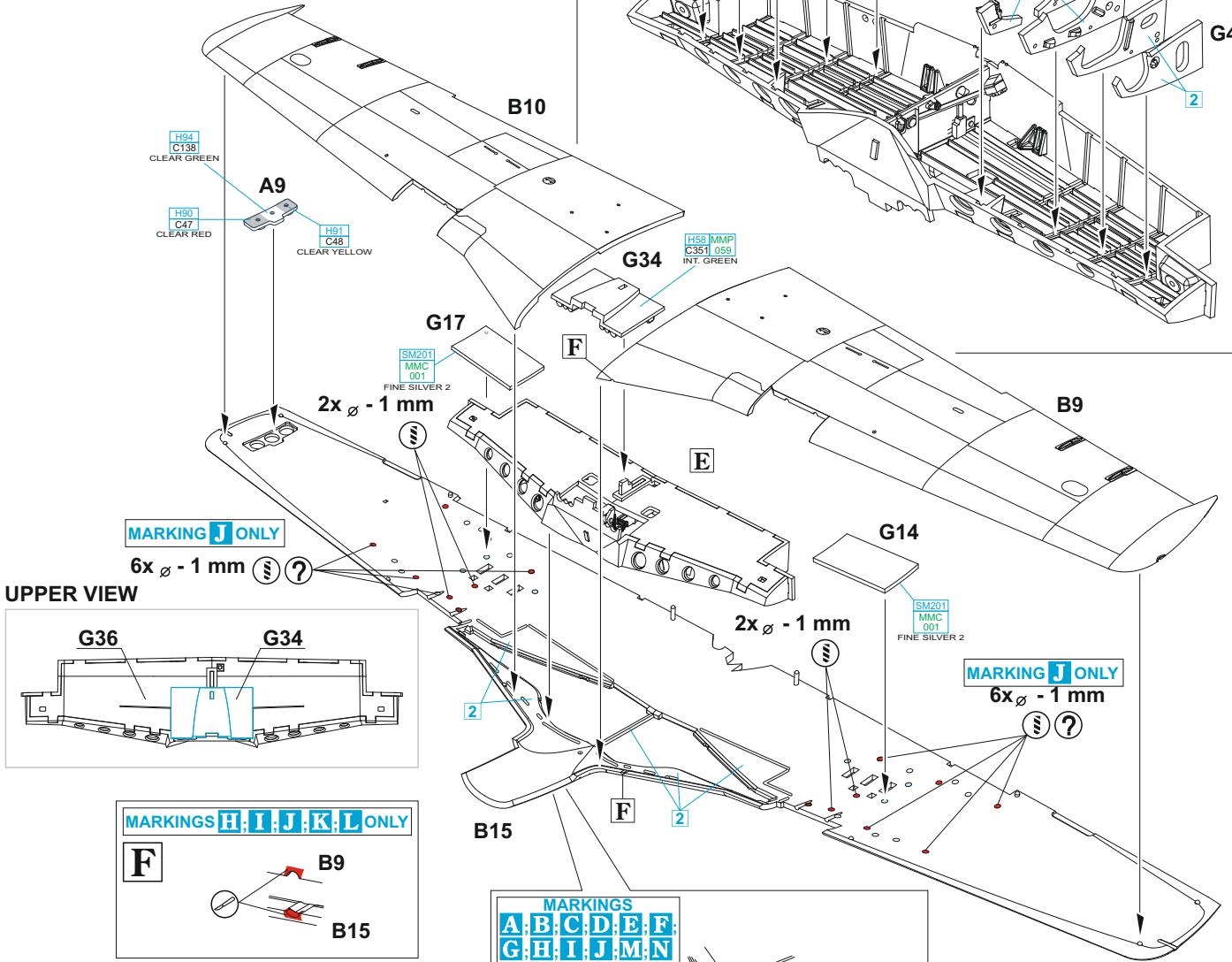
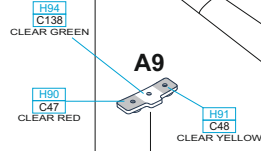
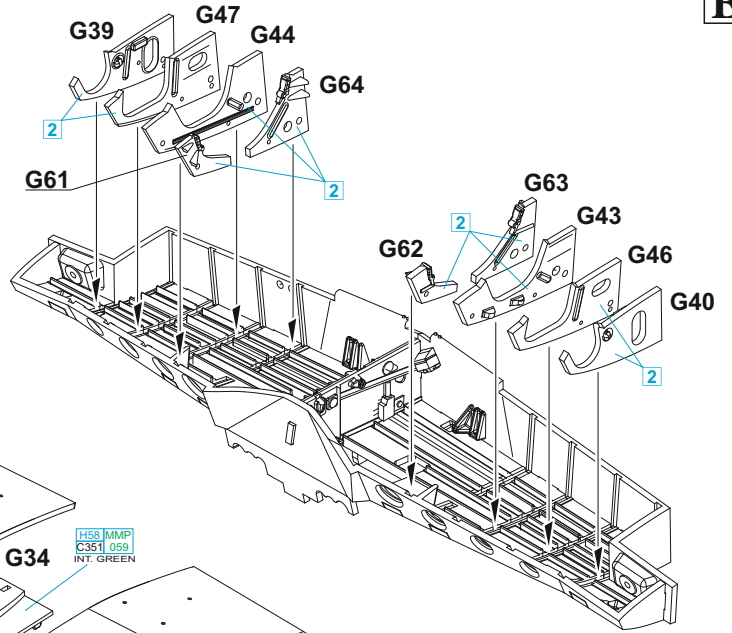
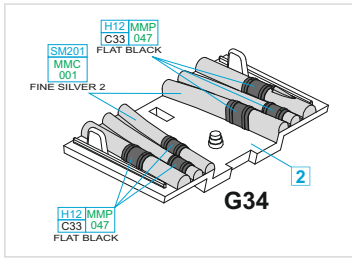

MARKING J ONLY

6x ø - 1 mm

UPPER VIEW

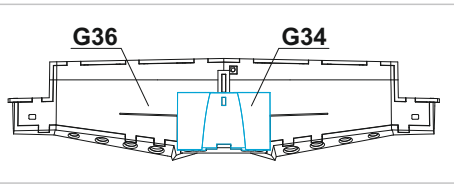

MARKINGS H, I, J, K, L ONLY

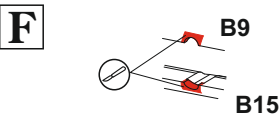

MARKINGS A, B, C, D, E, F, G, H, I, J, M, N ONLY

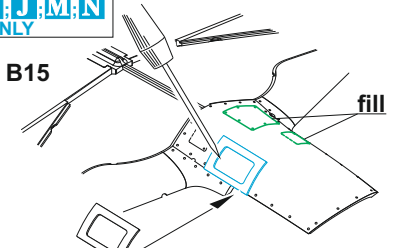

PE47 (PE28)

DO NOT GLUE!
NELEPIT!

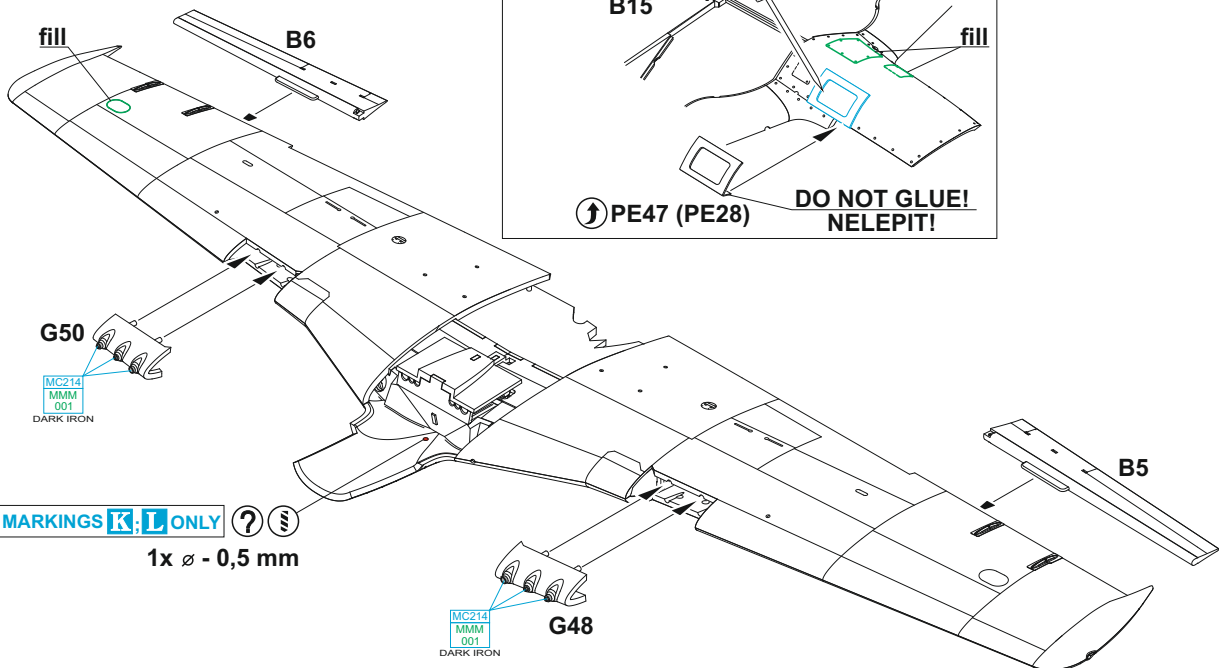

MARKINGS K, L ONLY

1x ø - 0,5 mm

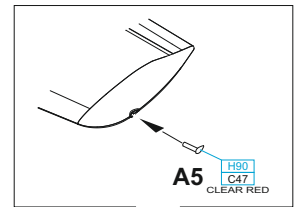
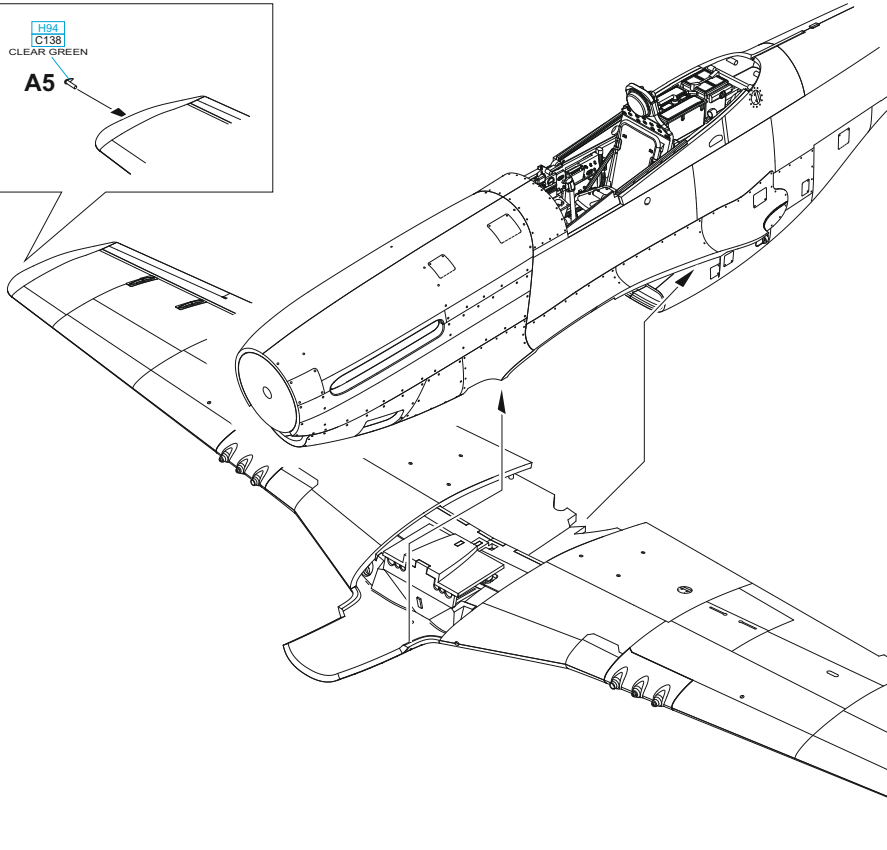
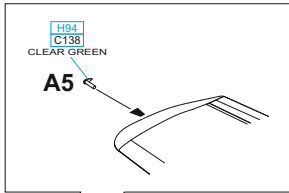

MARKINGS **A, B, C** ONLY

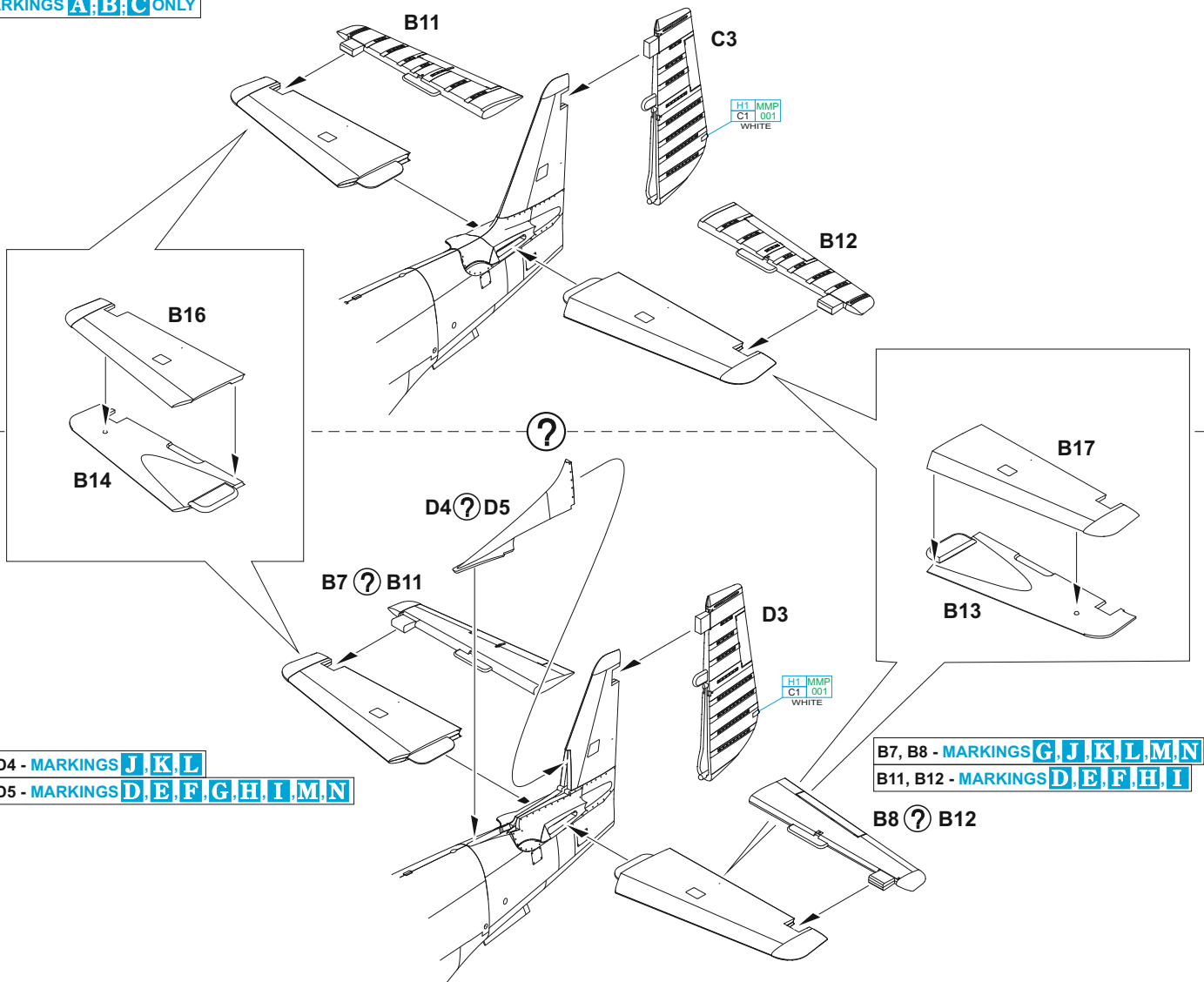

D4 - MARKINGS **J, K, L**

D5 - MARKINGS **D, E, F, G, H, I, M, N**

B7, B8 - MARKINGS **G, J, K, L, M, N**

B11, B12 - MARKINGS **D, E, F, H, I**

MARKINGS A,B,C,D,E,M,N

USE PHOTOETCHED SET No. 82101

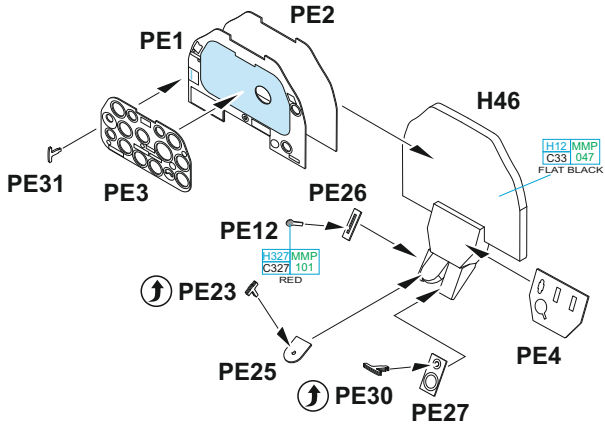

MARKINGS F,G,H,I,J,K,L

USE PHOTOETCHED SET No. 82102

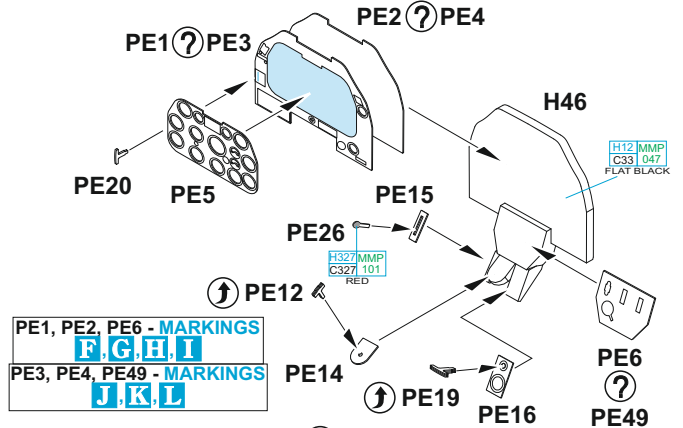

A8 right (A) A7 left (A)

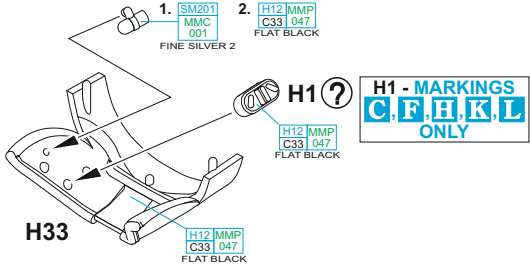

H44 - MARKINGS A,B,C,D,E,M,N
H45 - MARKINGS F,G,H,I,J,K,L

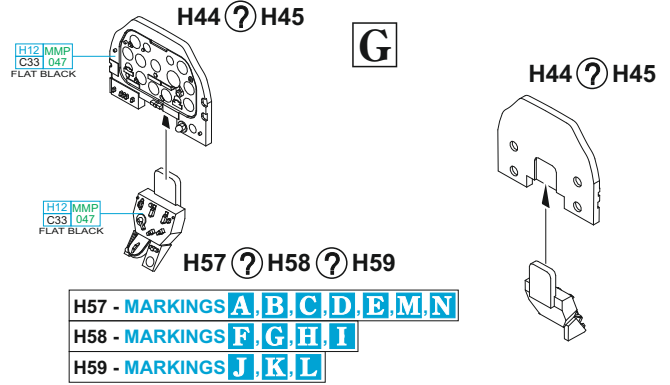

A3, A4 - MARKINGS C,F,H,K,L
A11 - MARKINGS A,B,D,E,G,I,J,M,N

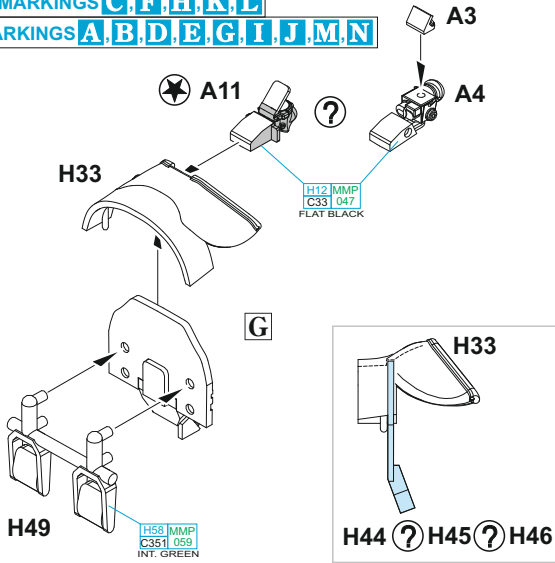

OPTIONAL:

- decals I1, I4, I5, I6, I7 - MARKINGS A,B,C,D,E,M,N
- decals I2, I4, I5, I6, I7 - MARKINGS F,G,H,I
- decals I3, I5, I6, I7, I8 - MARKINGS J,K,L

MARKINGS K,L ONLY

DO NOT GLUE!
NELEPIT!

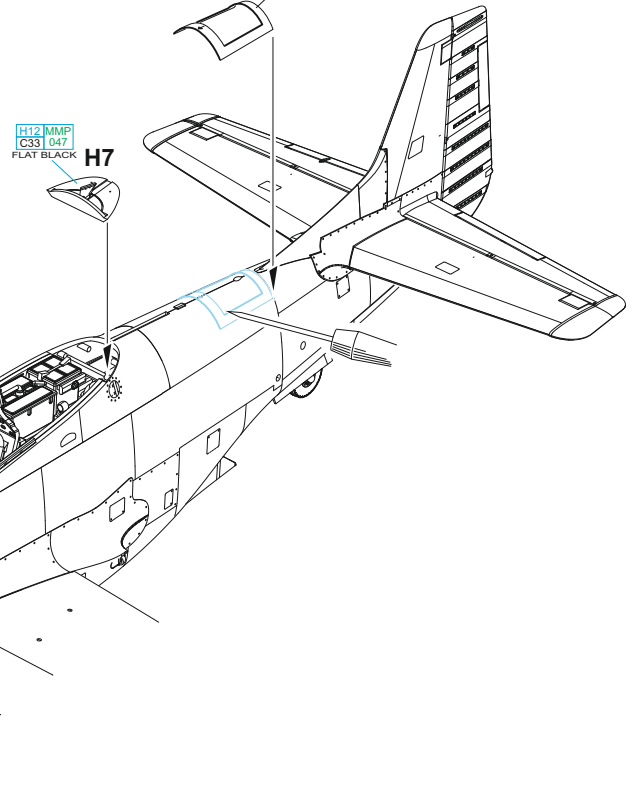

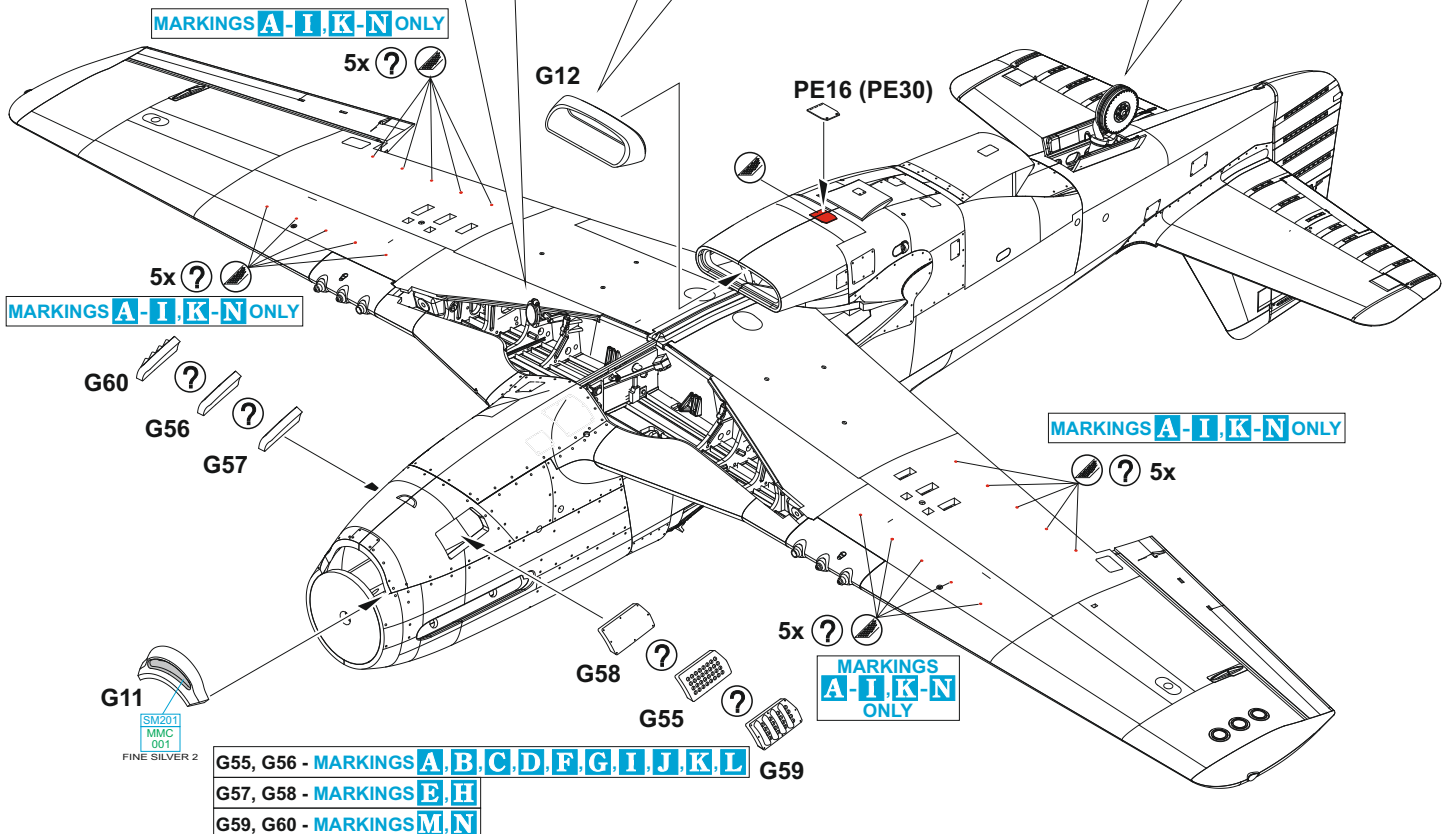
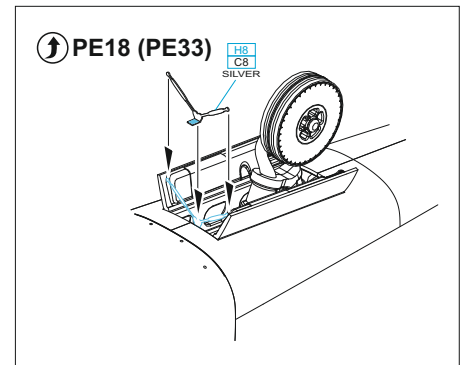
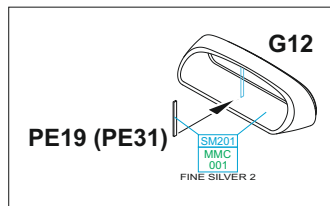
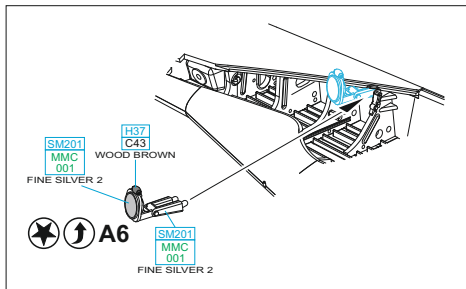
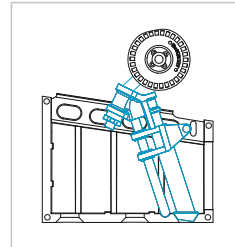
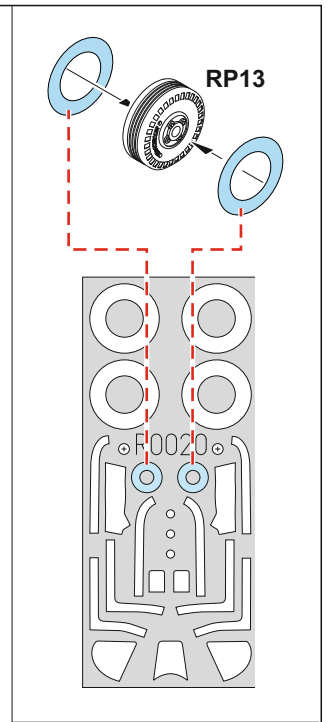
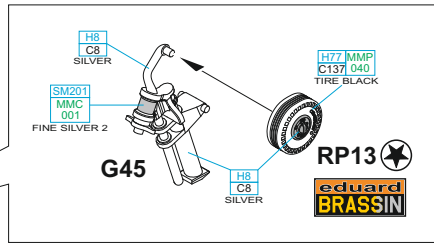
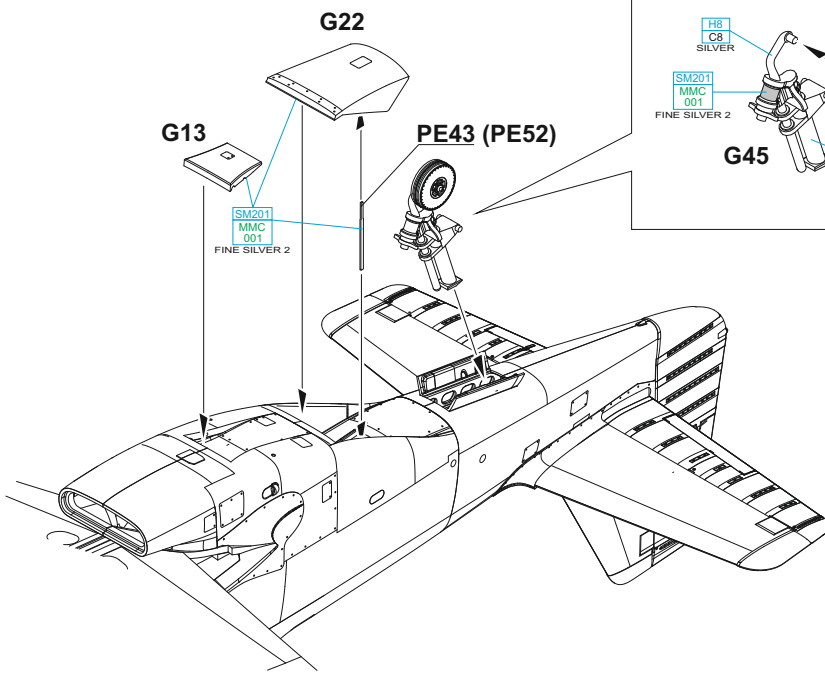

2 pcs.

RP11 ? RP18 ? RP19 ? RP20 ⊛

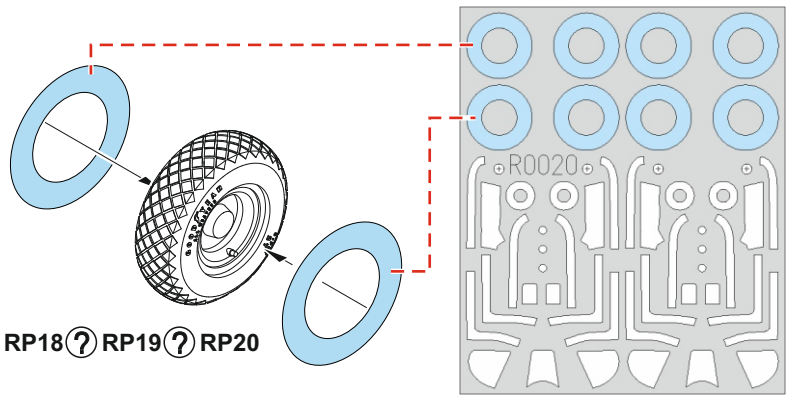
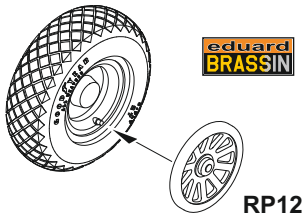

H

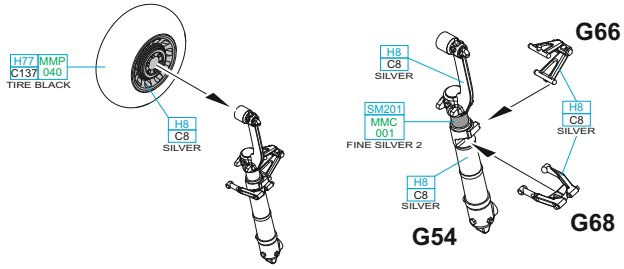

I

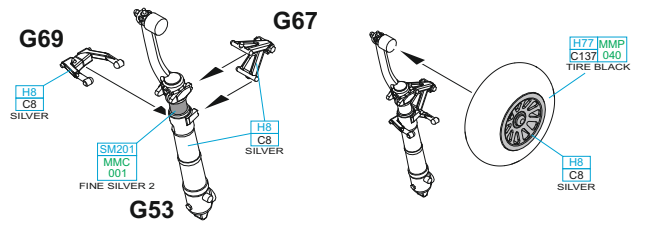

J

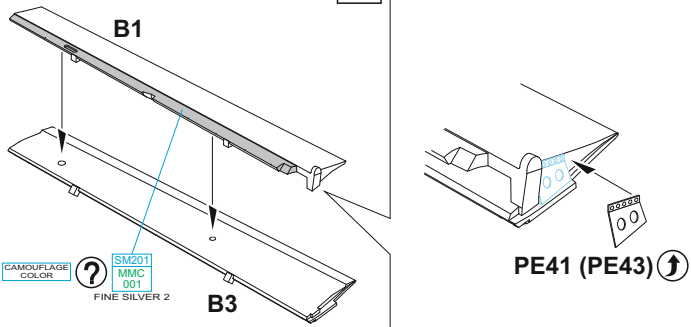

K

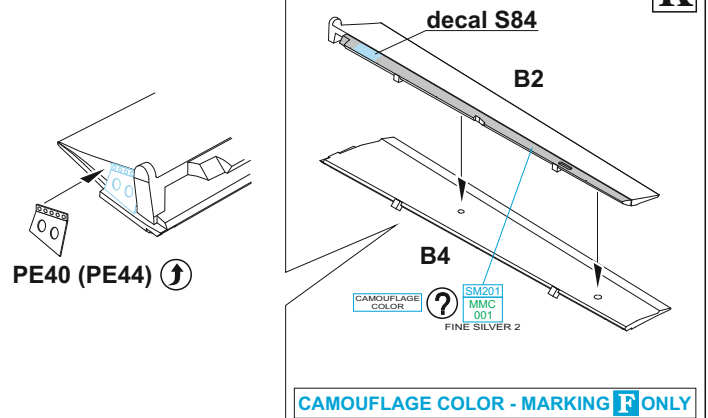

CAMOUFLAGE COLOR - MARKING F ONLY

CAMOUFLAGE COLOR - MARKING K ONLY

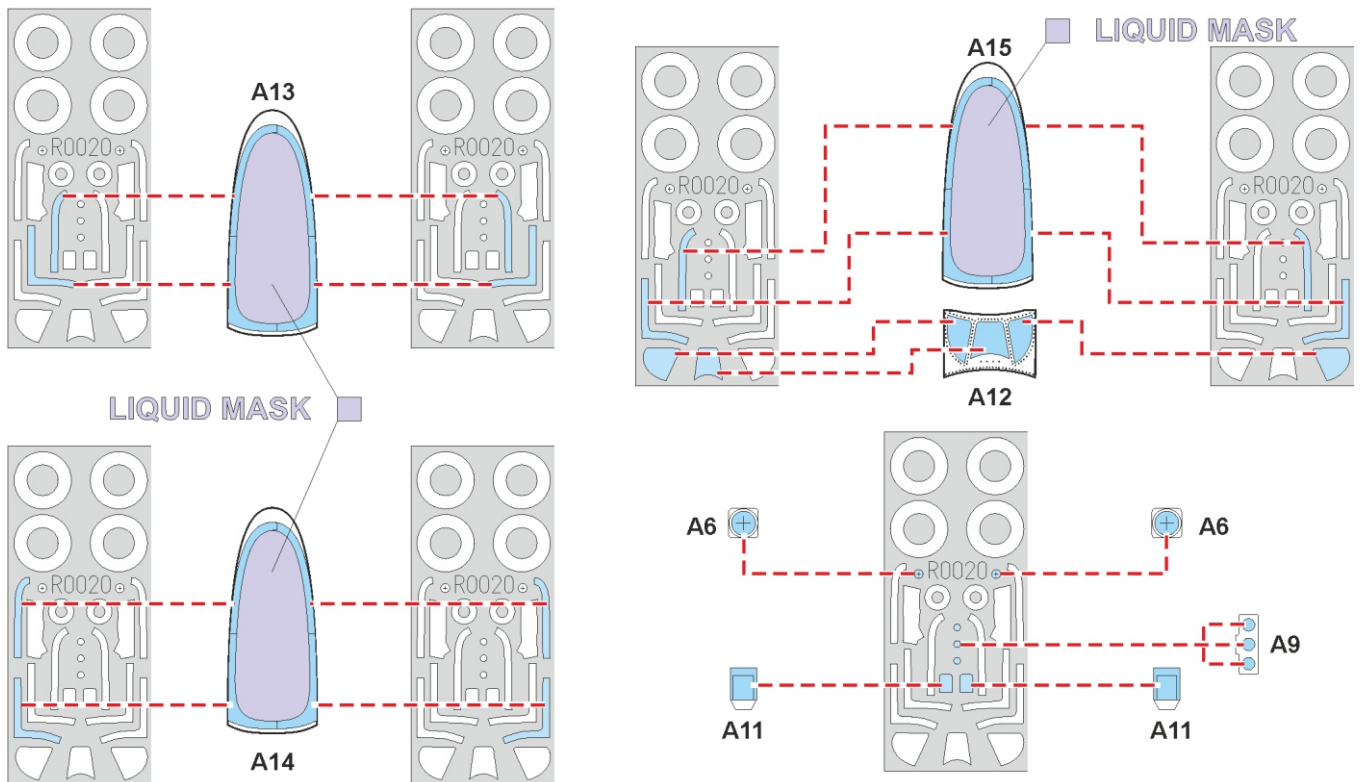

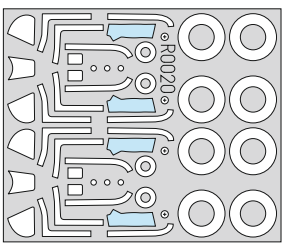
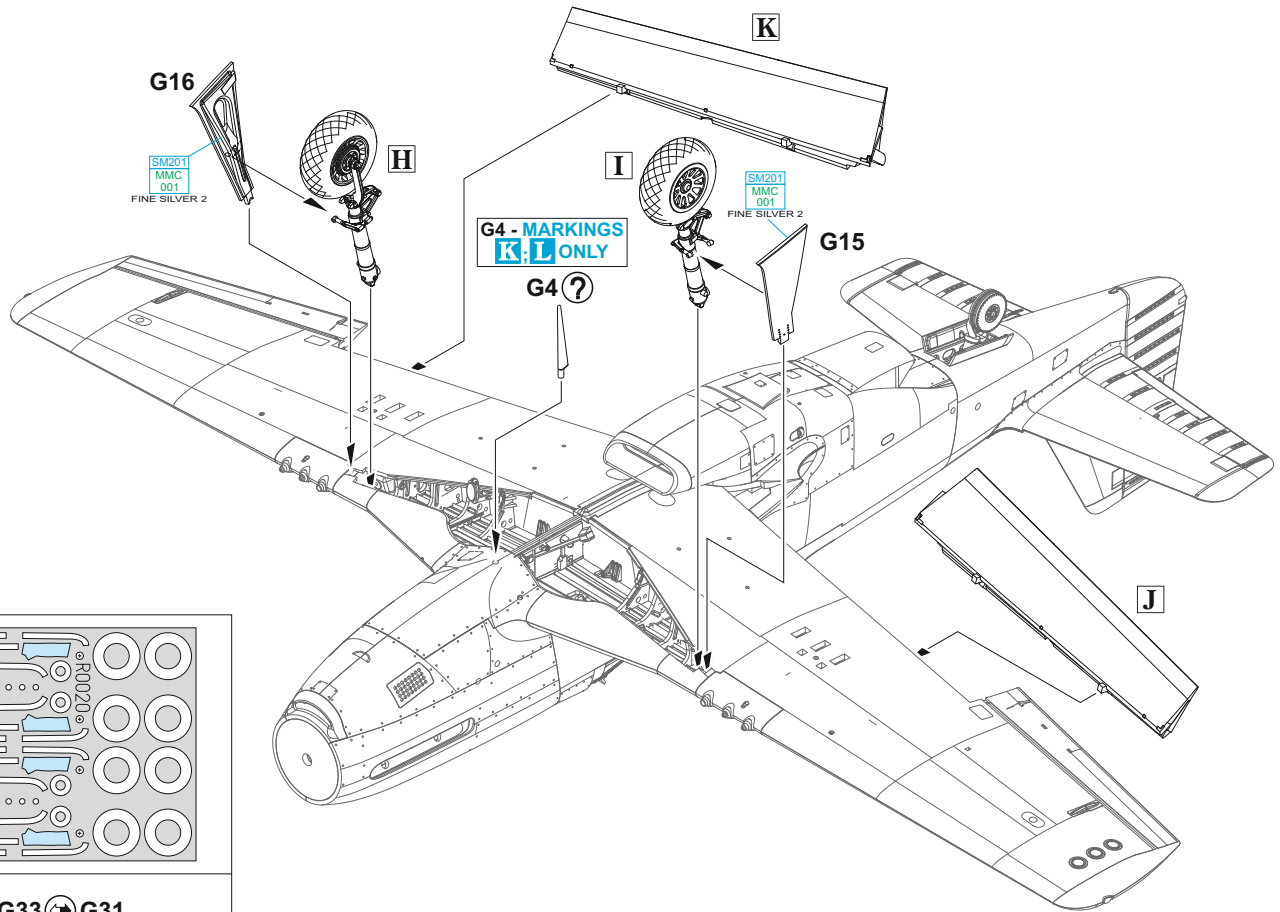

G33 ↔ G31

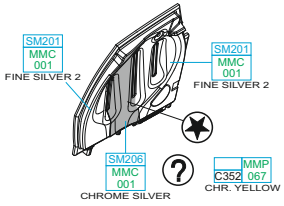

SM206 MMC 001 CHROME SILVER 2 - MARKINGS M; N ONLY

SM201 MMC 001 FINE SILVER 2

G65

G31

H8 CB SILVER

G33

SM201 MMC 001 FINE SILVER 2

G65

H8 CB SILVER

SM201 MMC 001 FINE SILVER 2

G10

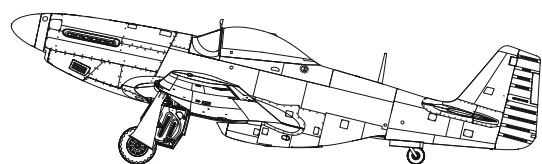
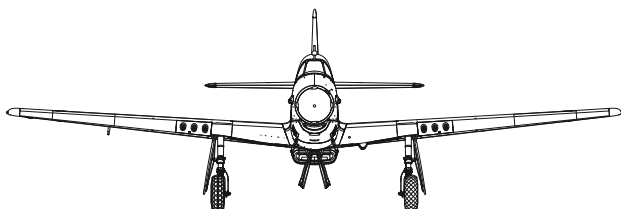

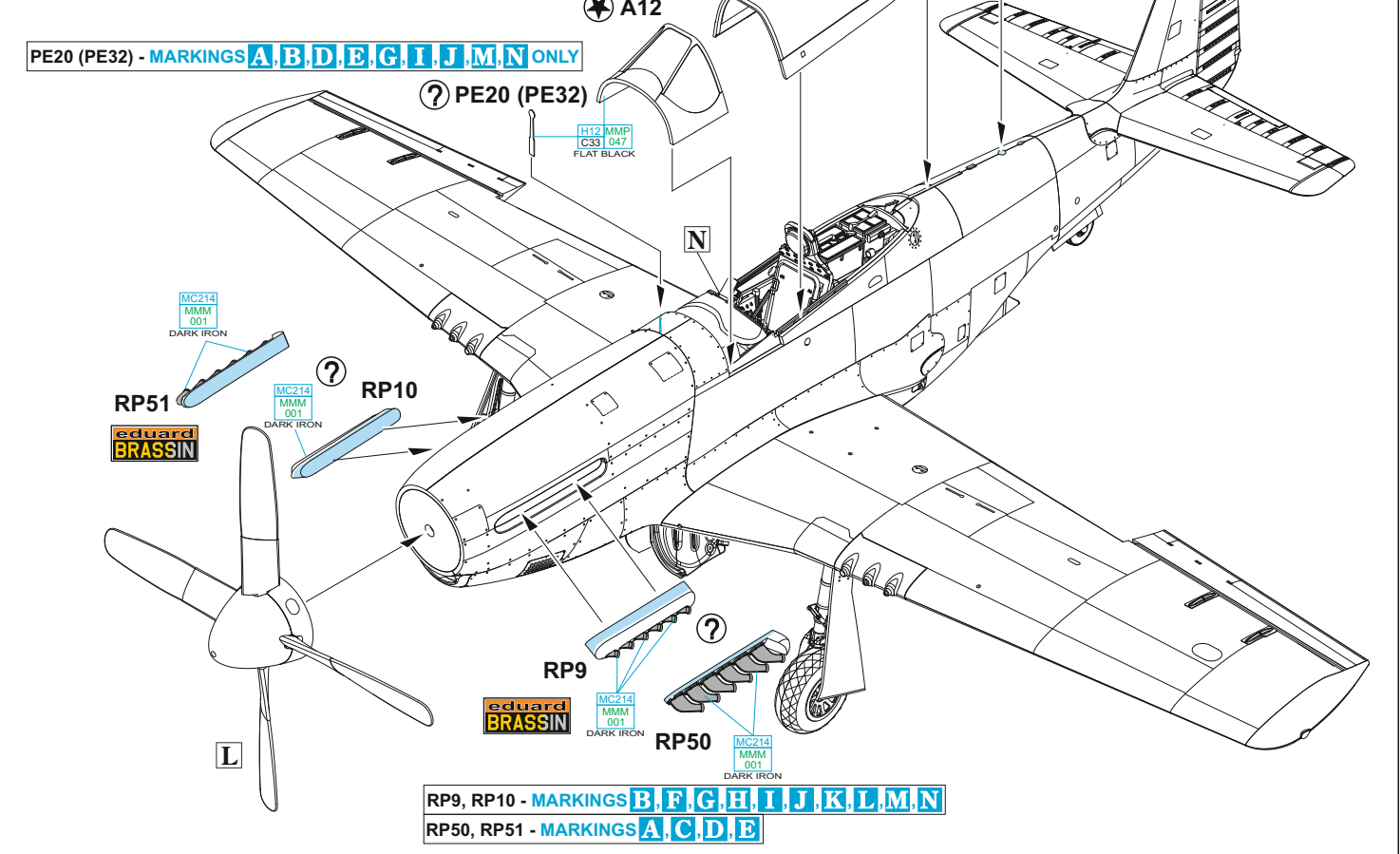
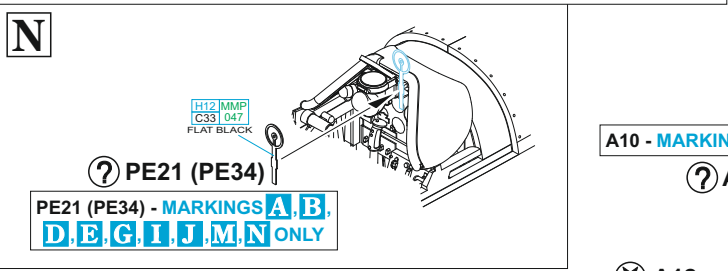
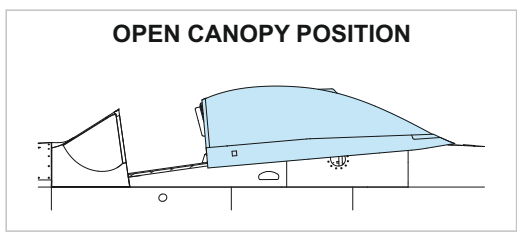
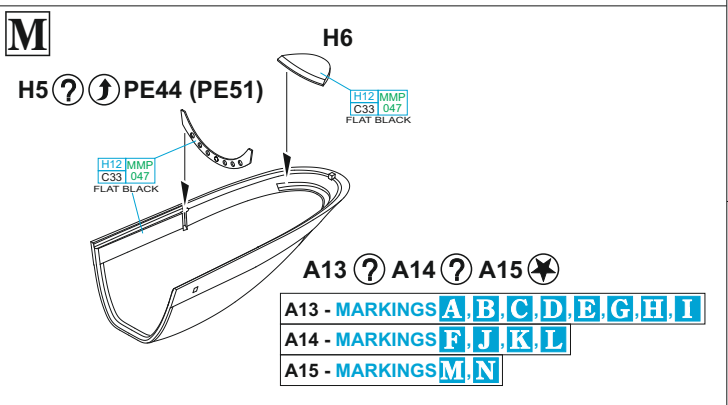
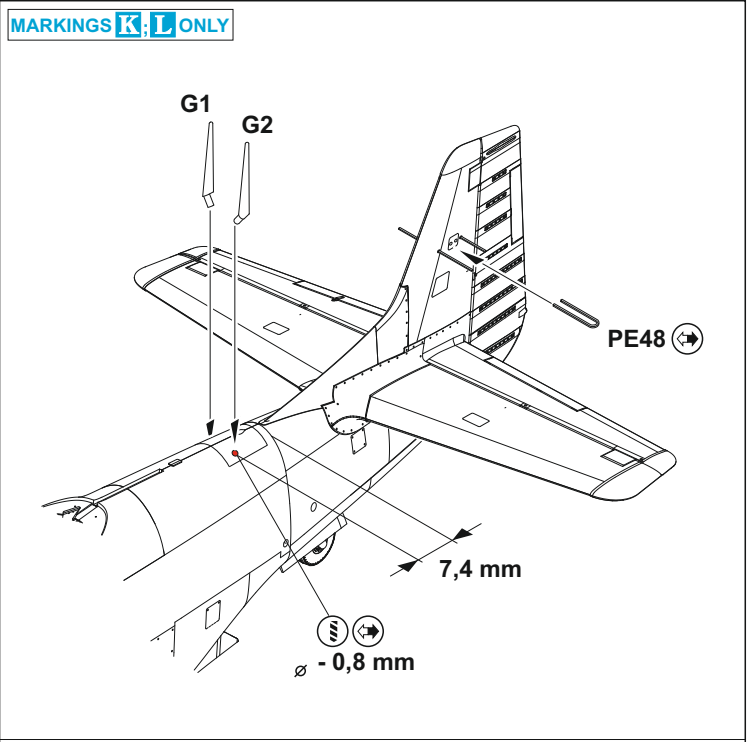
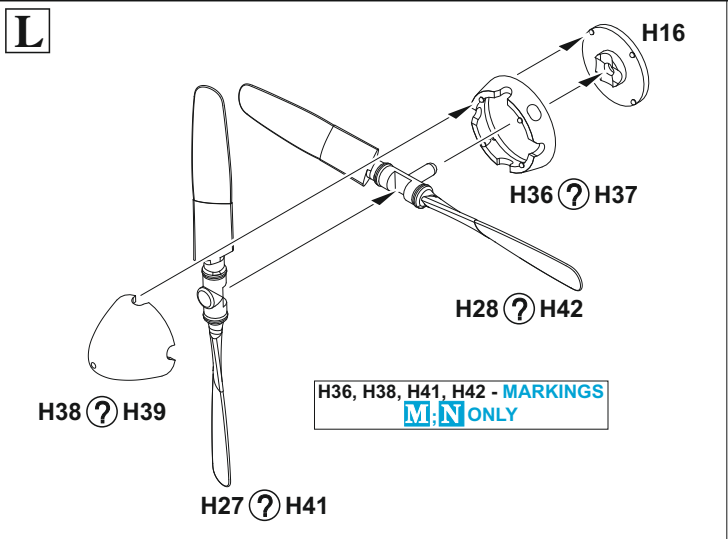

2 pcs.

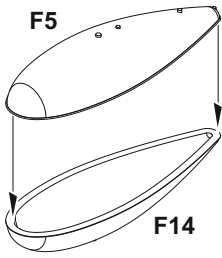

2 pcs.

?

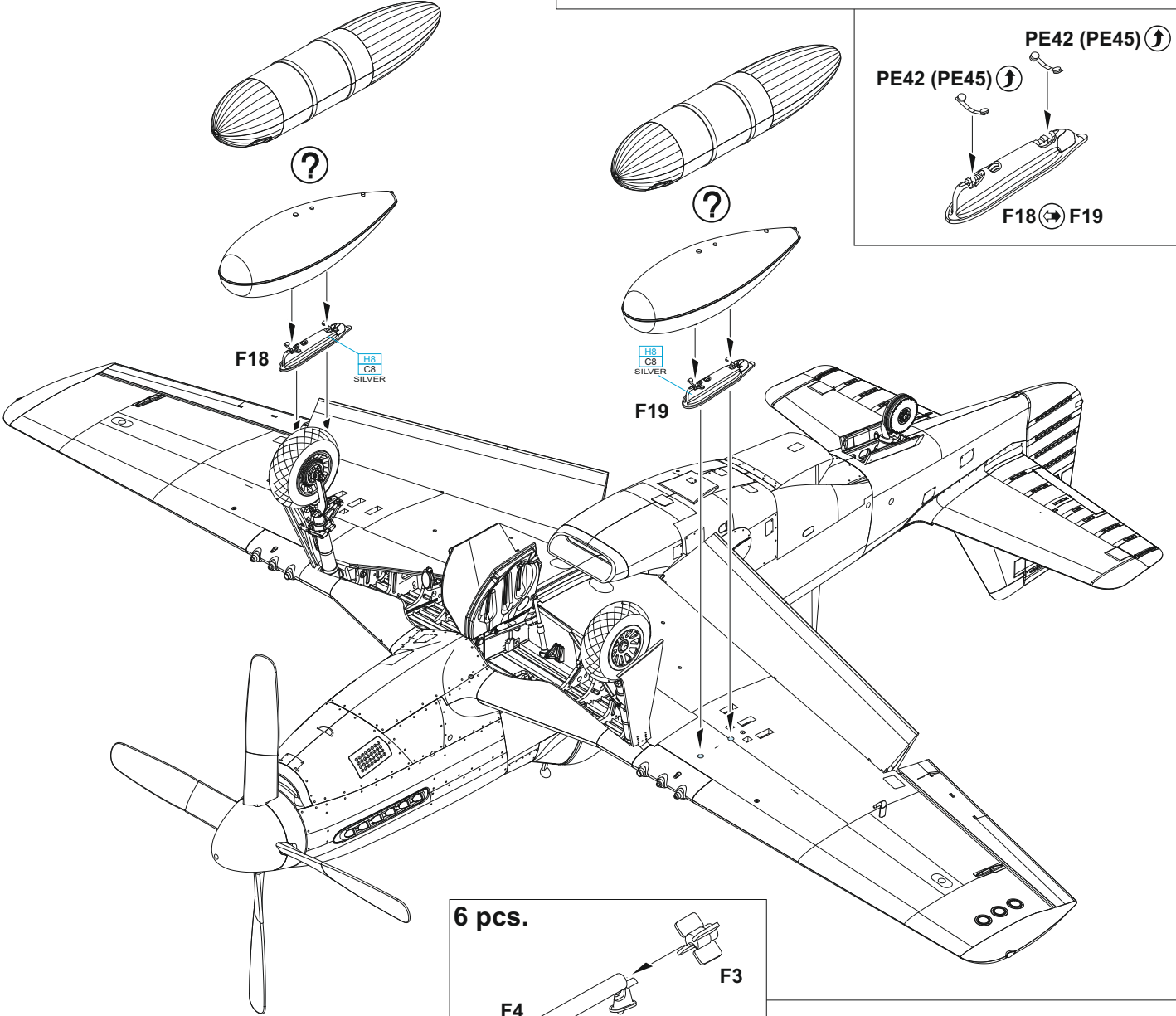
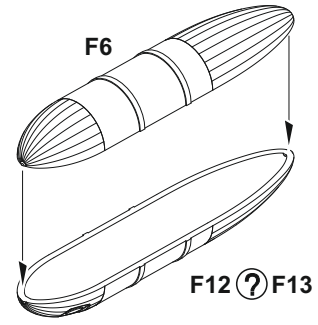

6 pcs.

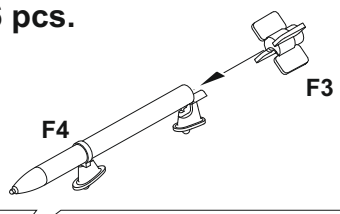

MARKING J ONLY

3 pcs.

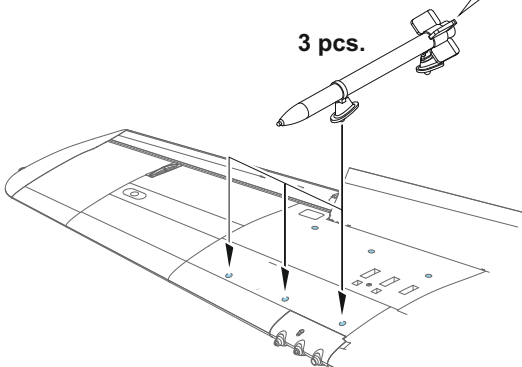

3 pcs.

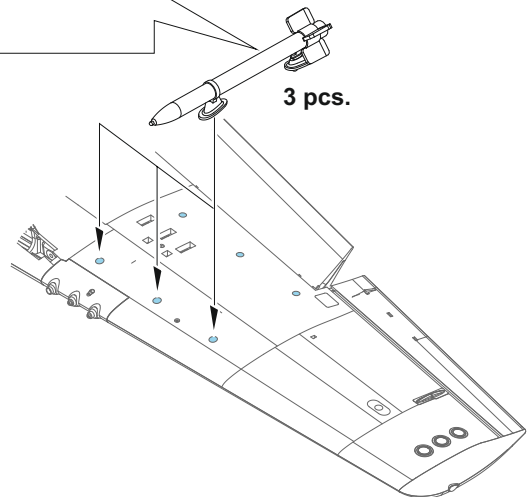

O

P

2 pcs.
J7

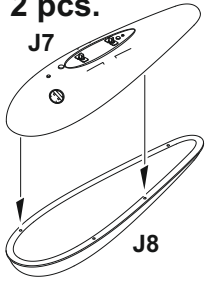

? J1 J4 ?

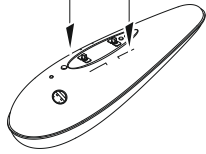

? J3 J2 ?

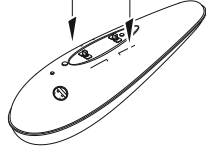

?

2 pcs.
J5

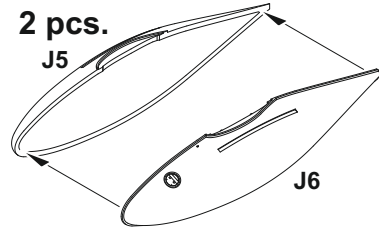

Q

? J12 J9 ?

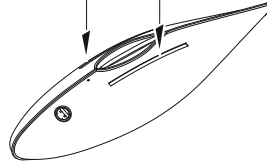

R

? J10 J11 ?

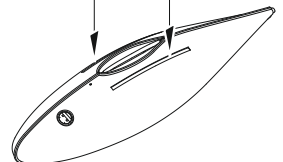

R

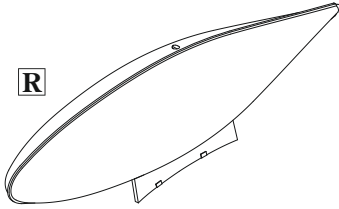

?

P

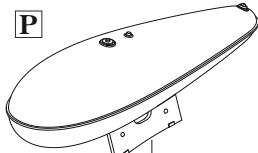

F18



H8
C8
SILVER

Q

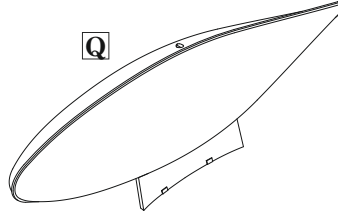

?

O

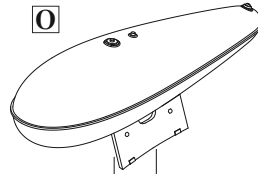

F19



H8
C8
SILVER

PE42 (PE45) ↑

PE42 (PE45) ↑

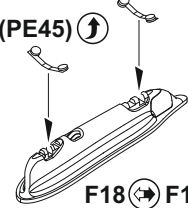

F18 ↔ F19

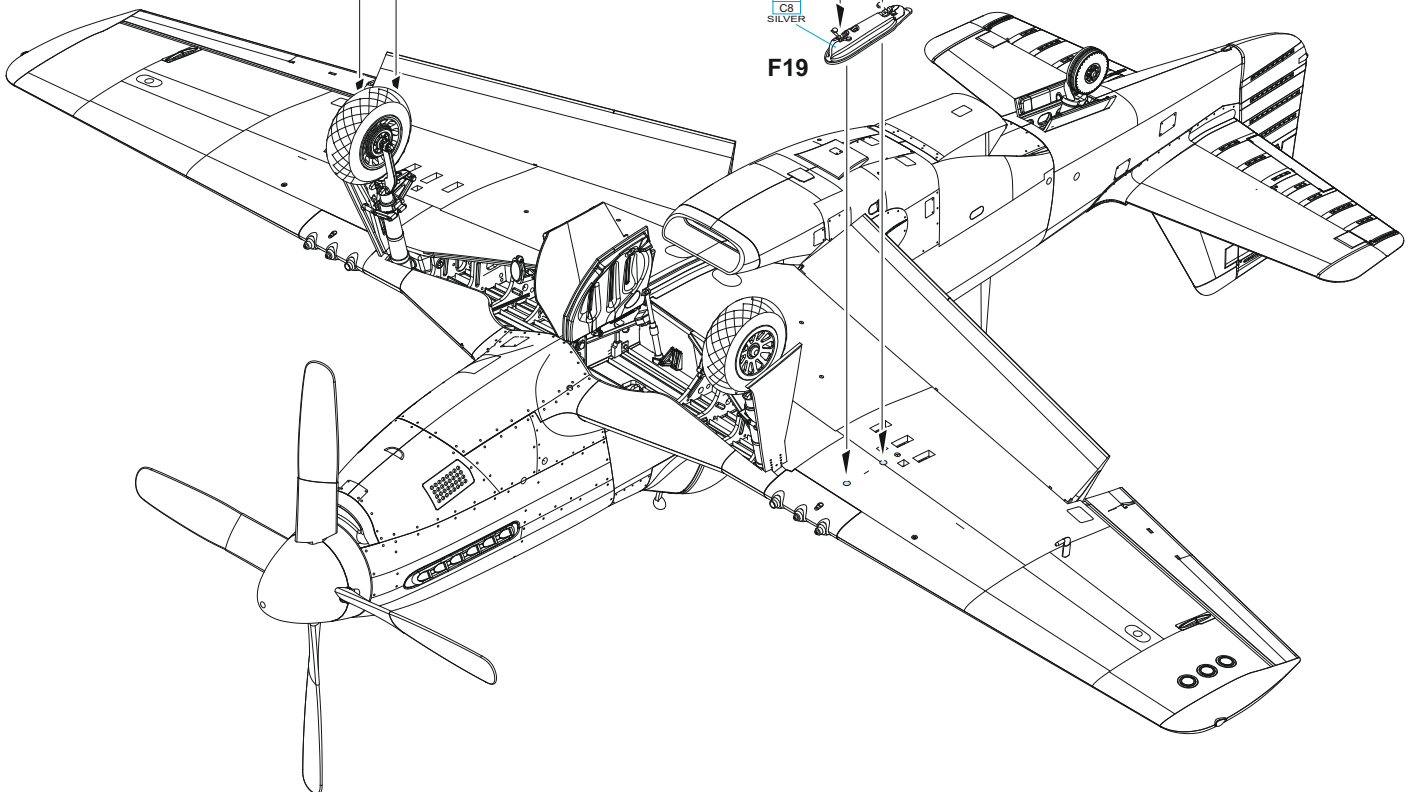

A P-51D-5, 44-13317, flown by Capt. Donald R. Emerson, 336th FS, 4th FG, 8th AF, Debden, United Kingdom, September 1944

4th FG was nicknamed Debden Eagles thanks to its home base and origins because it was formed from RAF Eagle squadron (71st, 121st and 133rd squadrons). After the incorporation into 8th AF the squadrons were re-named to 334th FS, 335th FS and 336th FS. Their Spitfires were replaced by P-47s as of April 1st, 1943 and in February 1944 these were replaced by P-51 aircraft. Donald Emerson joined the ranks of 4th Fighter Group on March 9th, 1944 and during the following eight months of duty he flew 89 sorties during which he was credited with 4.5 enemy aircraft shot down. On December 25th, 1944 he perished returning from the bomber escort mission when he spotted six Bf 109s. During the ensuing combat he descended close to the terrain and was hit by the anti-aircraft fire over the front. Pilot was probably killed and his aircraft crashed nearby the town of Sittard in The Netherlands. However he had managed to shot down two of his opponents. Capt. Emerson had the fuselage port side of his Mustang decorated with boxing Donald Duck in resemblance to his first name. There are seven kill markings painted under the windshield. From the beginning of September the invasion stripes on the upper wings and fuselage sides surfaces of the allied aircraft were deleted and left on the lower surfaces only.

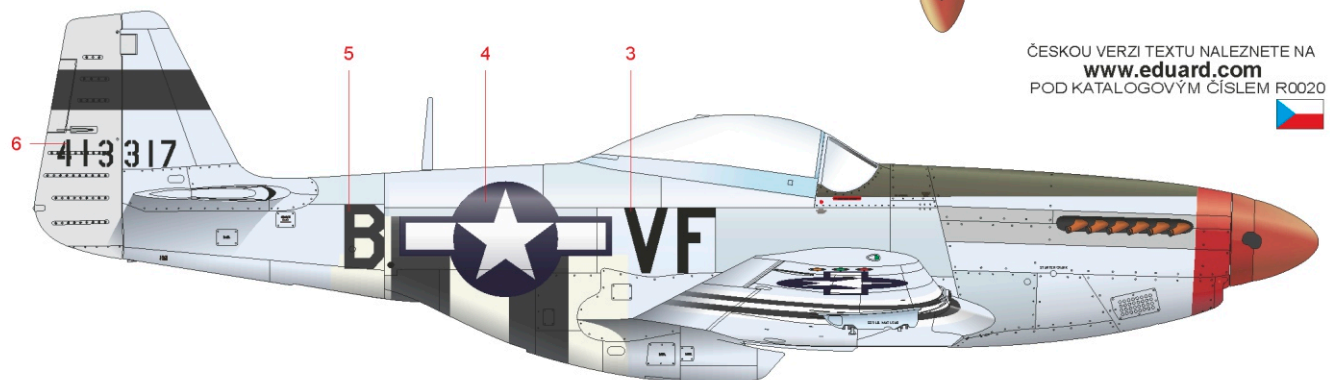
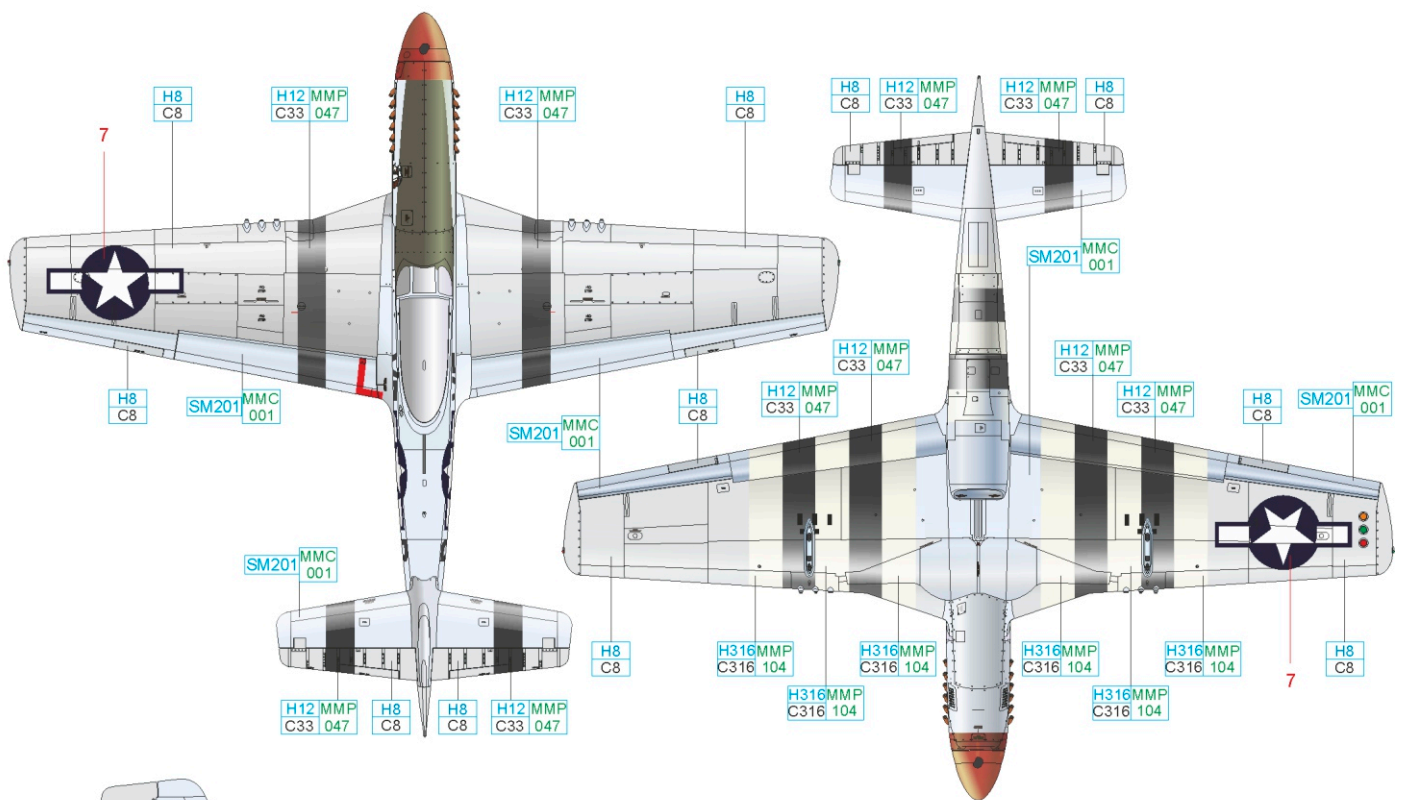
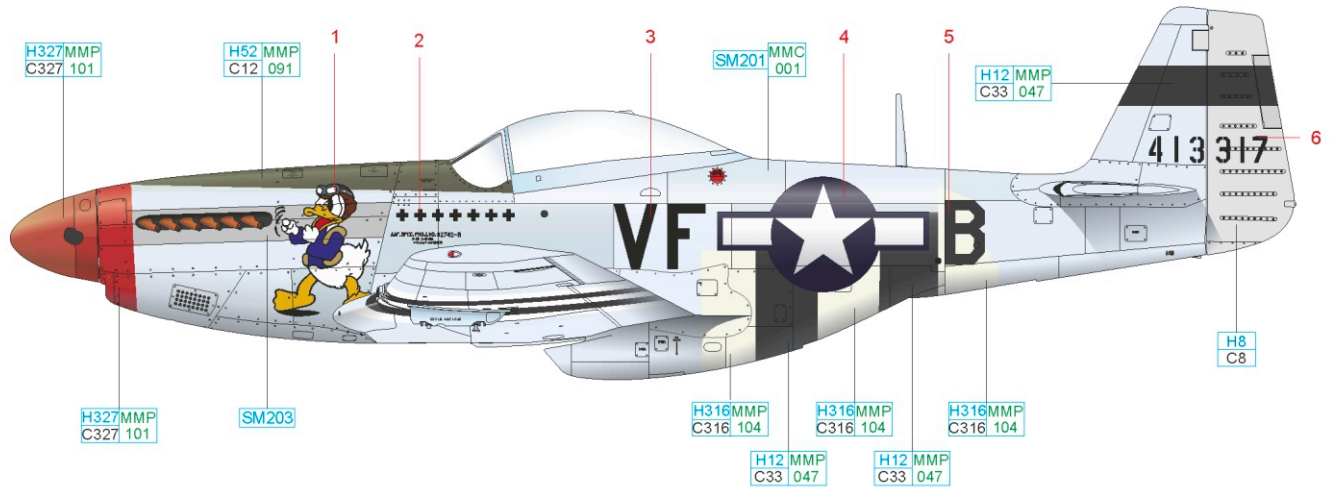

ČESKOU VERZI TEXTU NALEZNETE NA
www.eduard.com
 POD KATALOGOVÝM ČÍSLEM R0020



| | | | | | |
|-------------------|---------------------|------------|--------------------|------------|---------------------|
| WHITE | H316MMP C316 104 | BLACK | H12 MMP C33 047 | RED | H327MMP C327 101 |
| SUPER FINE SILVER | SM201 MMC 001 | SUPER IRON | SM203 | SILVER | H8 C8 |
| | | | | OLIVE DRAB | H52 MMP C12 091 |

B P-51D-5, 44-13500, flown by Capt. Robert J. Goebel, 308th FS, 31st FG, 15th AF, San Severo, Italy, 1944

December 22nd, 1939 is a birthday of 31st Pursuit Group which was renamed as Fighter Group on May 15th, 1942. On February 1st following year the unit was activated at Selfridge Field airport in Michigan and equipped with P-39 aircraft. In October 1942, after a short service with 8th AF, the unit was transferred to North Africa and incorporated into the 12th AF. During its deployment with 8th and 12th AF the unit was equipped with British Spitfires, after the transfer to 15th AF it received P-51 Mustangs. At the same time its mission changed to flying escorts to the heavy bombers. While the identification of the airplanes flying with 8th and 9th AF consisted of black or white stripes on the wing and tail surfaces the aircraft operating in the south of Europe carried yellow stripes. Red nose and spinner was also part of the recognition marking of the 15th AF fighters. To help friend-or-foe identification during the bomber escort sorties 31st FG aircraft carried red diagonal stripes on the tail surfaces. Lt. Goebel named his machine Flying Dutchman.

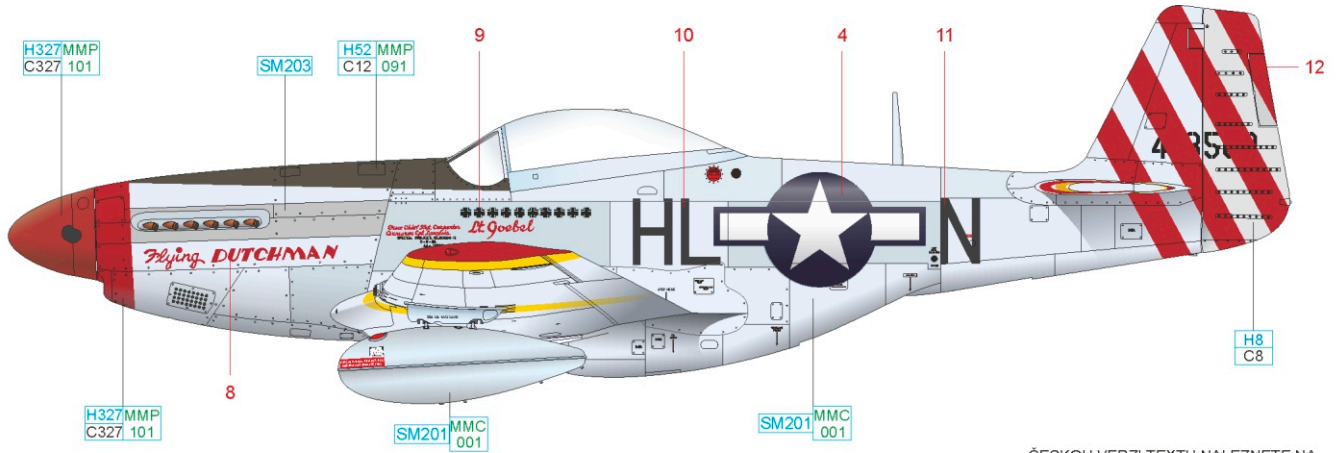

ČESKOU VERZI TEXTU NALEZNETE NA
www.eduard.com
 POD KATALOGOVÝM ČÍSLEM R0020

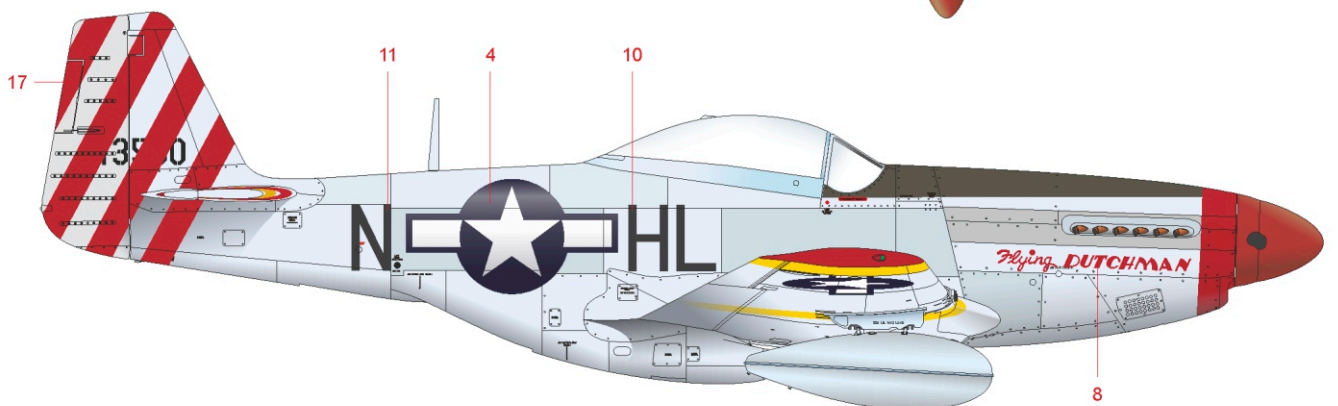
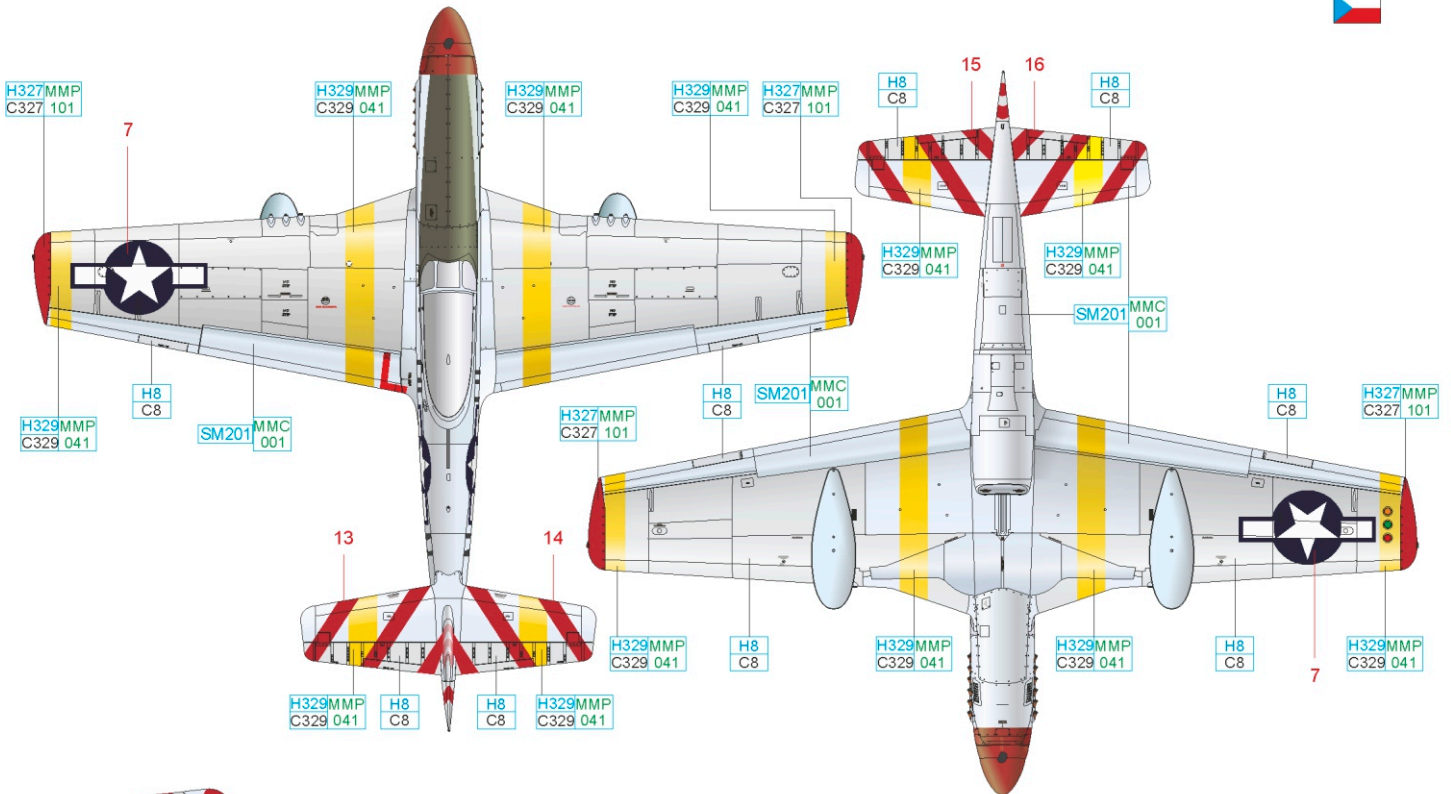

| | | | | | |
|----------------------|---------------------|---------------|---------------------|---------------|--------------------|
| YELLOW | H329MMP C329 041 | RED | H327MMP C327 101 | OLIVE DRAB | H52 MMP C12 091 |
| SUPER FINE SILVER | SM201 MMC 001 | SUPER IRON | SM203 | SILVER | H8 C8 |

C P-51D-5, 44-13561, flown by Maj. Richard E. Turner, 356th FS, 354th FG, 9th AF, Orconte, France, September 1944

The birth of 354th Fighter Group is dated November 12th, 1942, when it was formed at Hamilton Field airport in California. After the initial hassle and bustle the training started on P-39 aircraft. After its transfer to Europe in November 1943 the 354th FG personnel was informed about the incorporation into the 9th Air Force fighter groups and at the same time about the re-equipment with P-51B Mustangs. Among all fighter groups fighting in the European Theater during the World War Two, 354th FG pilots achieved the highest number of enemy aircraft shot down (701 kills). 356th Fighter Squadron machines proudly carried the black noses with white stars. Maj. Turner had the nose of his Mustang decorated with the inscription which appears on the other aircraft he flew, sometimes slightly modified. The fuselage side of his aircraft is marked with symbols of his victories over the enemy.

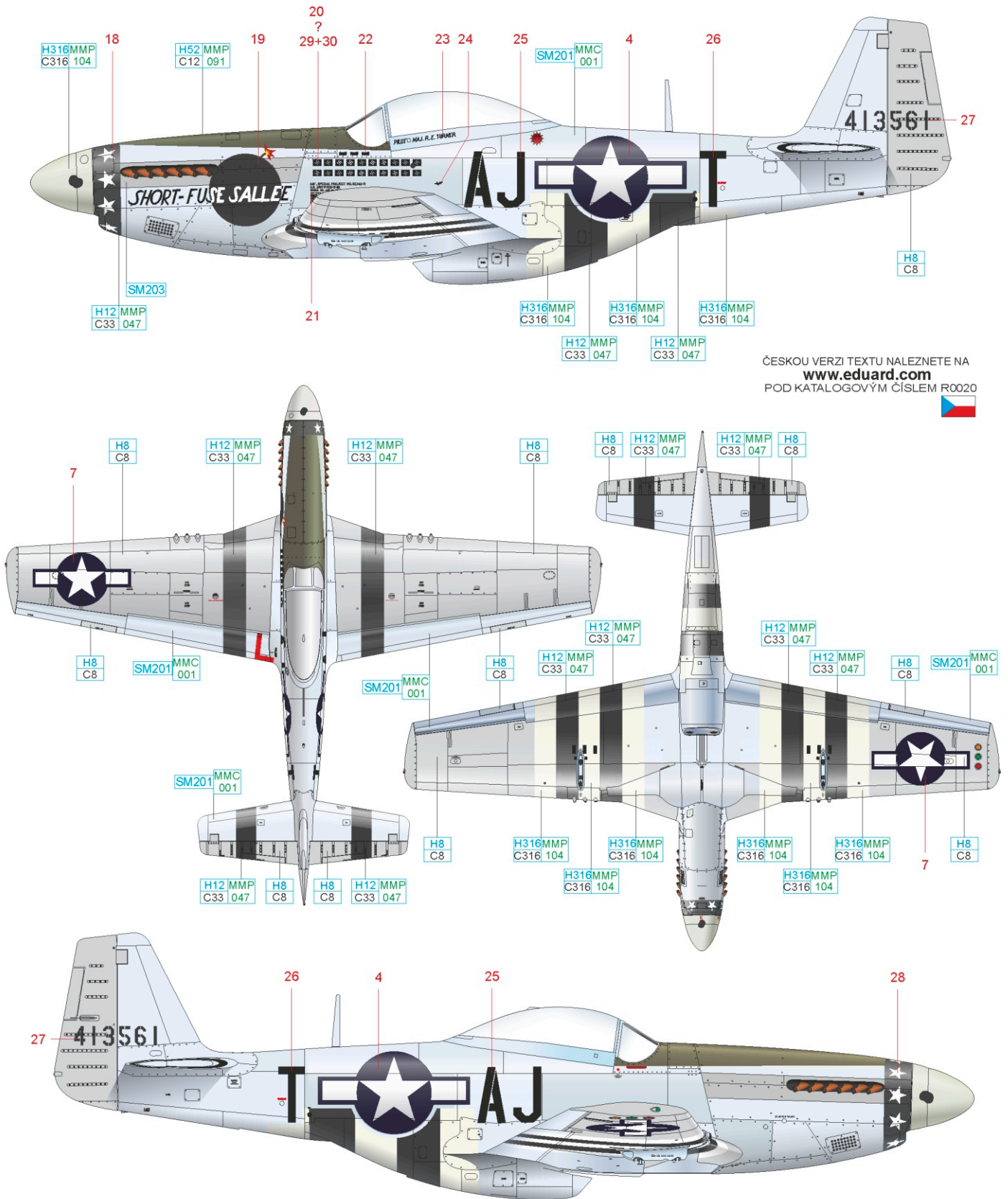

ČESKOU VERZI TEXTU NALEZNETE NA
www.eduard.com
 POD KATALOGOVÝM ČÍSLEM R0020



| | | | | | |
|----------------------|---------------------|---------------|-------------------|---------------|-------------------|
| WHITE | H316MMP C316 104 | BLACK | H12MMP C33 047 | OLIVE DRAB | H52MMP C12 091 |
| SUPER FINE SILVER | SM201 MMC 001 | SUPER IRON | SM203 | SILVER | H8 C8 |

D P-51D-5, 44-13693, flown by 2nd Lt. Bruce W. Carr, 353rd FS, 354th FG, 9th AF, Orconte, France, October 1944

Bruce W. Carr started his pilot training on September 2nd, 1942. After its completion on August 30th, 1943, he added to his qualification ratings on A-36 and P-51A and after that he was dispatched to 380th FS. On March 8th, 1944 he recorded his first victory and consequently was re-assigned to 353rd FS becoming one of the 354th Fighter Group aces. On November 2nd, 1944 during the fighter sweep over the occupied Czechoslovakia his aircraft was hit by the anti aircraft fire. Bruce Carr bailed out and after landing undetected penetrated the Luftwaffe airbase where he was able to capture Fw 190A-6 fighter and return with it to his home base in Orconte. During the World War Two he was credited with 15 enemy aircraft shot down. He continued with his aviation career after the war, flew combat in Korea and Vietnam as well. He passed away in April 1998 in Florida. 353rd FS aircraft noses and spinners were painted yellow with added black triangles on the engine cowling. As the majority of fighter pilots Capt. Bruce Carr too had his score painted under the windshield in the form of small swastikas.

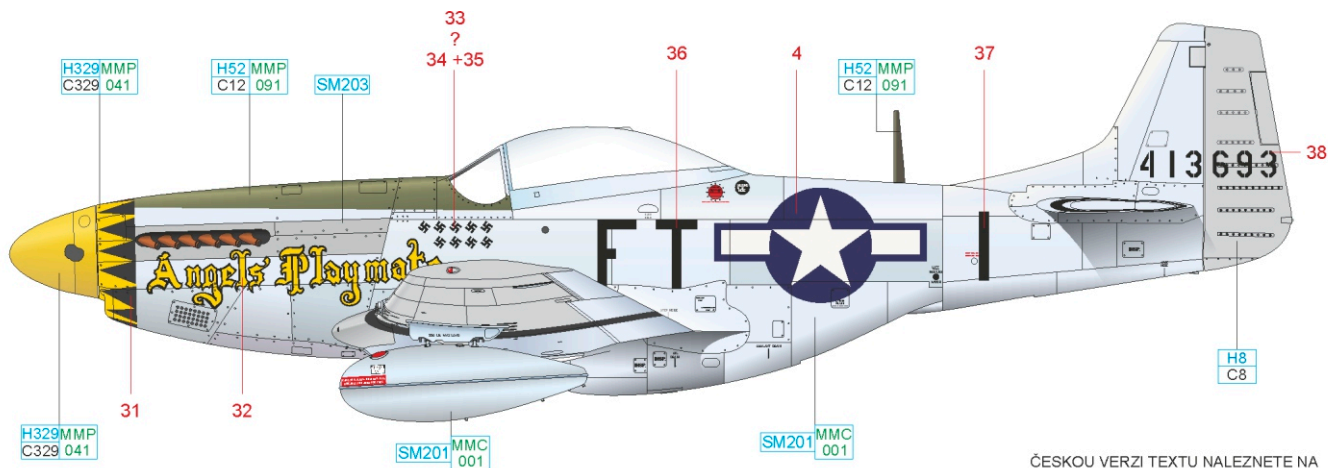

ČESKOU VERZI TEXTU NALEZNETE NA
www.eduard.com
 POD KATALOGOVÝM ČÍSLEM R0020

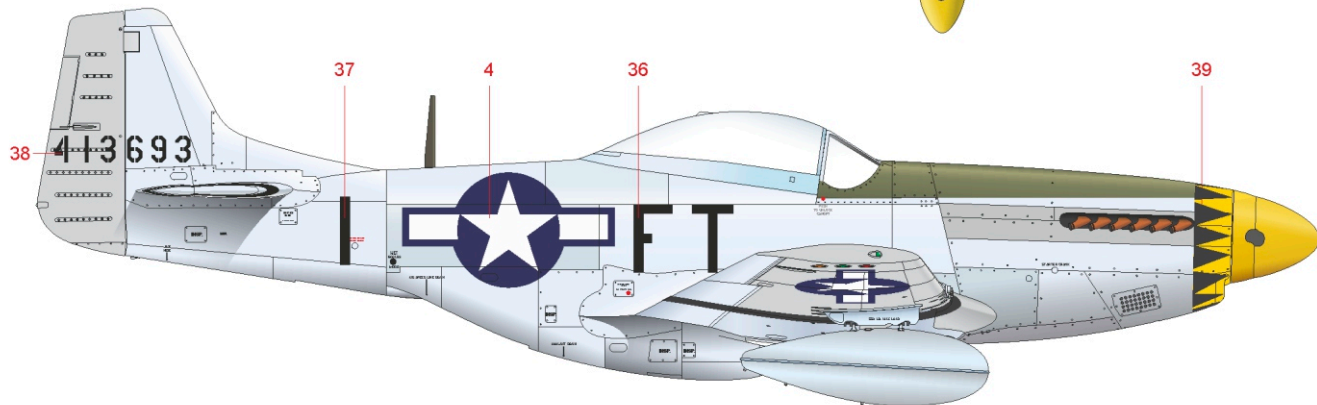
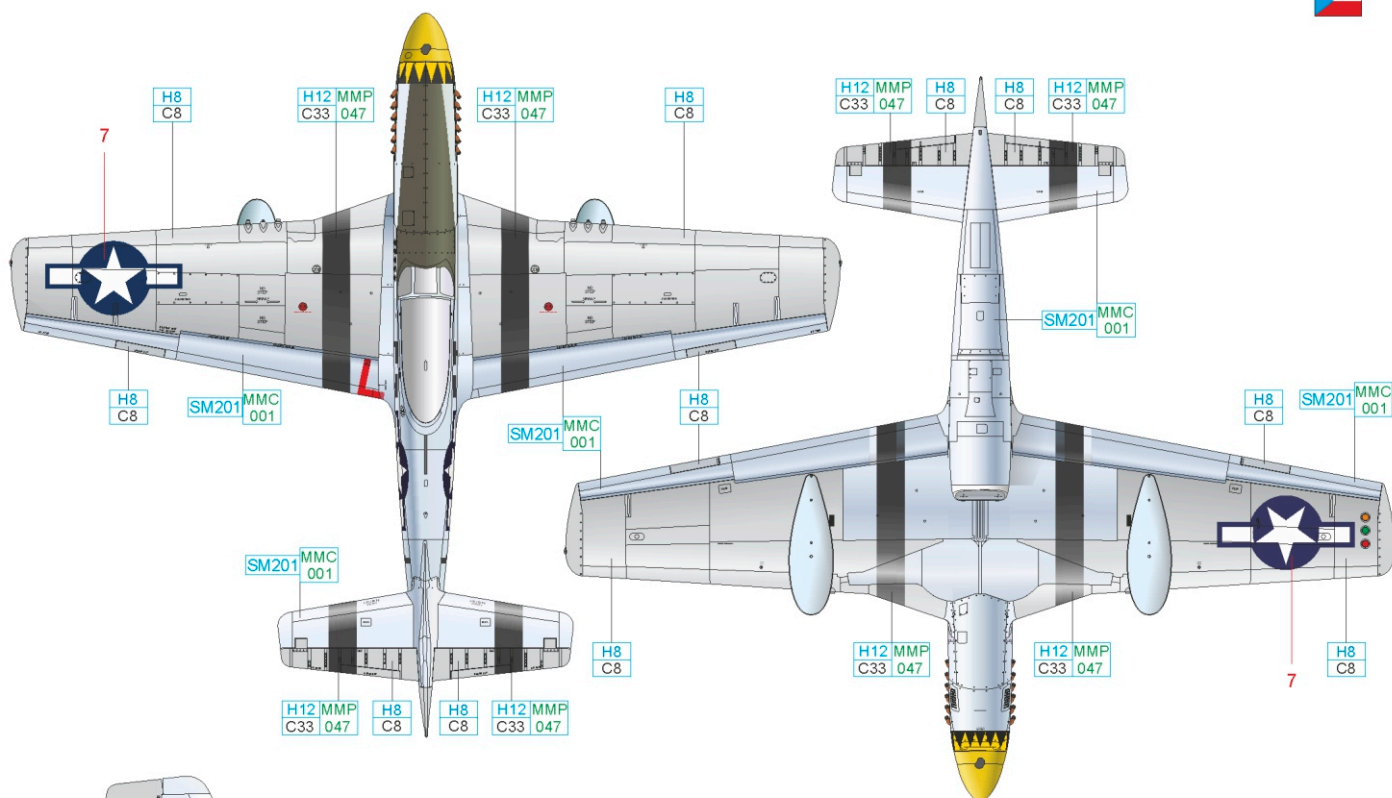

| | | | | | |
|----------------------|---------------------|---------------|--------------------|--------|--------------------|
| YELLOW | H329MMP C329 041 | OLIVE DRAB | H52 MMP C12 091 | BLACK | H12 MMP C33 047 |
| SUPER FINE SILVER | SM201 MMC 001 | SUPER IRON | SM203 | SILVER | H8 C8 |

E P-51D-5, 44-13837, flown by Lt. Richard Ozinga, 343rd FS, 55th FG, 8th AF, Wormingford, United Kingdom, September 1944

55th Fighter Group history starts in January 1941 by establishing 55th Pursuit Group at Hamilton airbase in California. In May 1943 it was re-named to 55th FG, started training on P-43 aircraft and finished it on P-38. On October 15th, 1943 having been transferred to Great Britain the unit was declared combat-ready on P-38H. In July 1944 it was re-equipped with P-51D flying mostly four engine bombers' escorts till the end of war. On August 20th, 1946 the unit was disbanded. Richard Ozinga was assigned to 343rd FS after he completed his pilot training on August 2nd, 1944 and flew with this unit until the end of World War Two. Besides him also 2nd Lt. Kenneth J. Mix and Lt. Robert E. Welch logged several flights in this aircraft. Richard Ozinga passed away on April 8th, 1994. 55th Fighter Group aircraft noses received green-yellow checkerboards for better mid-air recognition. The same colors appeared on the propeller spinners. Typical for this unit was the coloration of its Mustangs fuselages when the olive drab antiglare panel was extended to the rear fuselage. Yellow rudder was the 343rd FS recognition marking. Richard Ozinga named his aircraft by his girlfriend and later wife Marilyn.

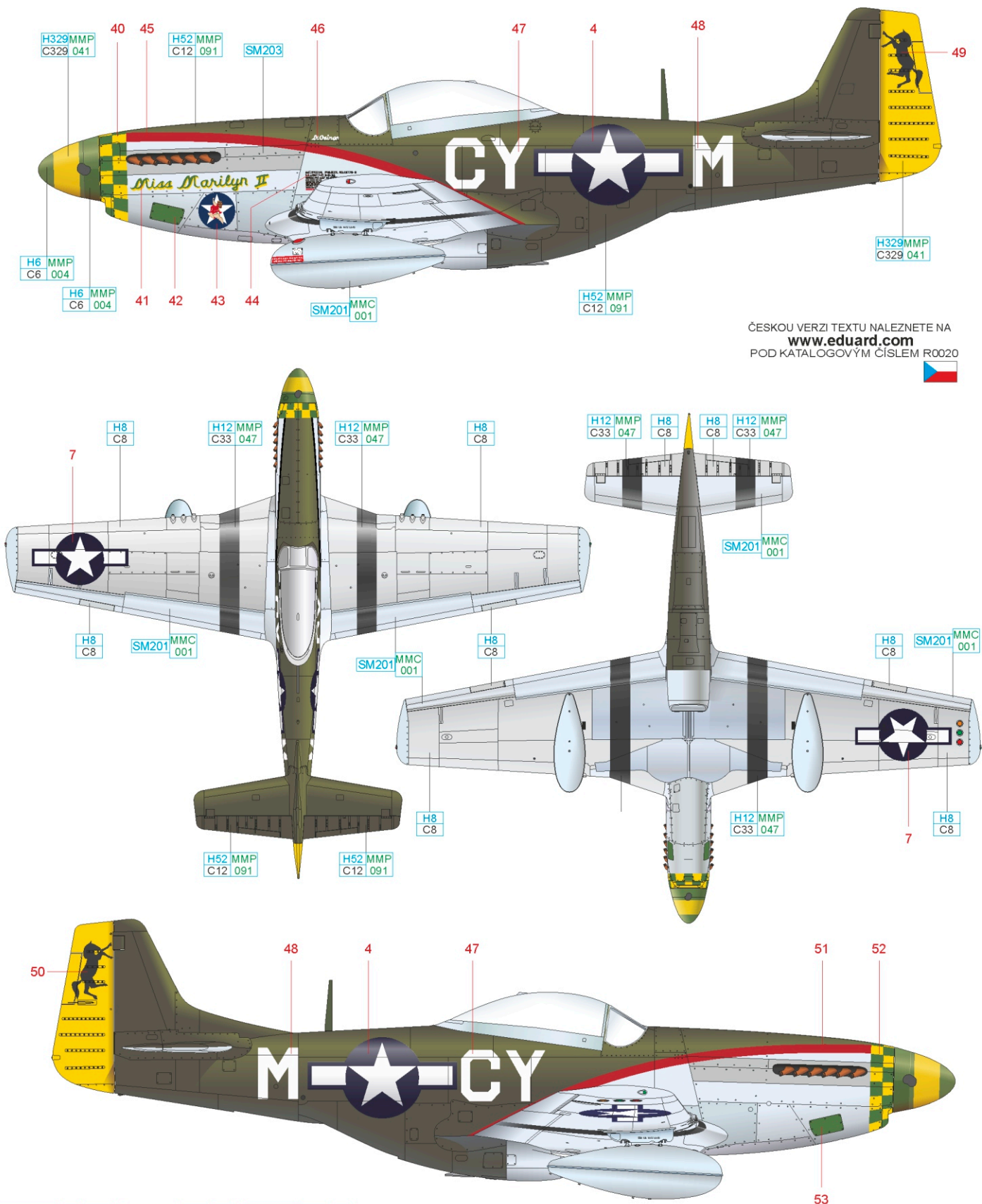

ČESKOU VERZI TEXTU NALEZNETE NA
www.eduard.com
 POD KATALOGOVÝM ČÍSLEM R0020



| | | | | | |
|-------------------|---------------------|------------|--------------------|--------|--------------------|
| YELLOW | H329MMP C329 041 | OLIVE DRAB | H52 MMP C12 091 | GREEN | H6 MMP C6 004 |
| SUPER FINE SILVER | SM201 MMC 001 | SUPER IRON | SM203 | SILVER | H8 C8 |
| | | | | BLACK | H12 MMP C33 047 |

F P-51D-10, 44-14798, flown by Maj. Joseph Broadhead, 357th FG, 8th AF, Leiston, United Kingdom, January 1945

357th Fighter Group became the first 8th Air Force fighter group equipped with P-51 Mustang with which, in November 1943, it underwent the training at British airbase Raydon. It entered into the combat with enemy in February operating from Leiston airbase. The unit personnel was nicknamed Yoxford Boys first time by the commentator of British Broadcasting of the German Radio during the night after their arrival in Leiston airbase located nearby the village of Yoxford. Joseph Broadhead commanded the incorporated 362nd FS from March 10th to August 25th, 1944 when having completed his second tour of duty he was sent back to United States for recuperation. After that he returned to 357th FG for his third tour of duty which he completed in February 1945. His score in World War Two was eight kills. Maj. Broadhead machine carried on the nose port side the inscription Master Mike (his previously flown P-51B was christened Baby Mike). Number of sorties flown was marked above the exhaust in the form of little bombs. It is not clear what kind of camouflage paint was applied on 357th FG aircraft. While the veterans speak about British colors Dark Green and Medium Sea Gray the period color pictures point us towards American colors Olive Drab and Neutral Gray. 357th FG aircraft noses were decorated with yellow-red checkerboard, the propeller spinners were painted in the same colors.

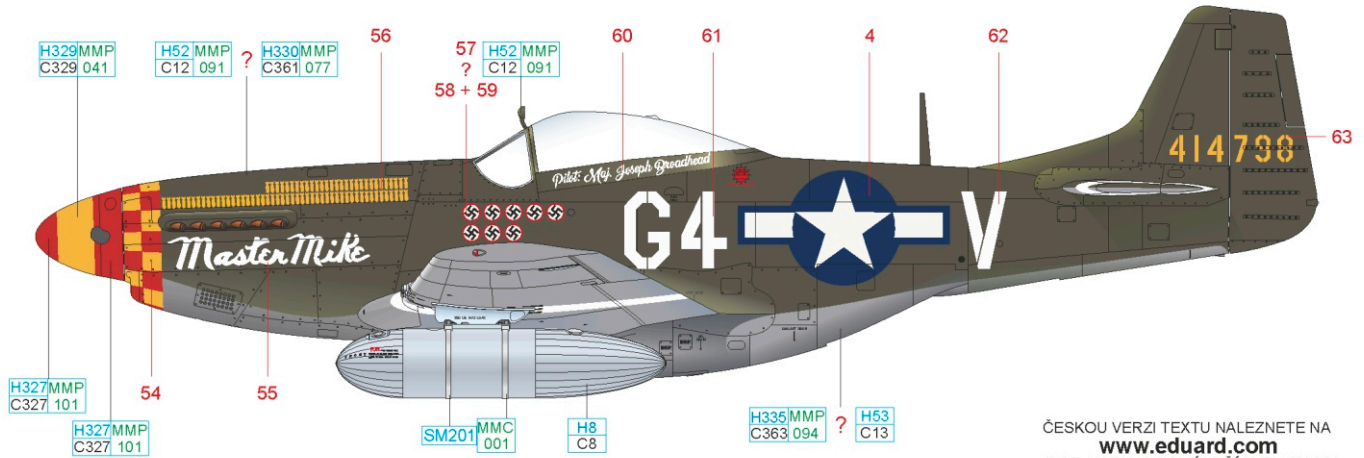

ČESKOU VERZI TEXTU NALEZNETE NA www.eduard.com
POD KATALOGOVÝM ČÍSLEM R0020

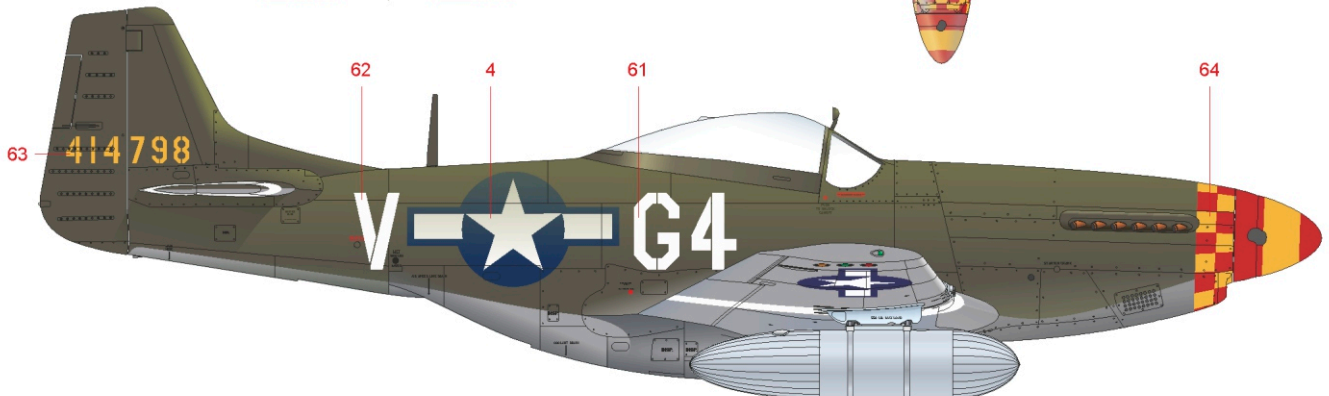
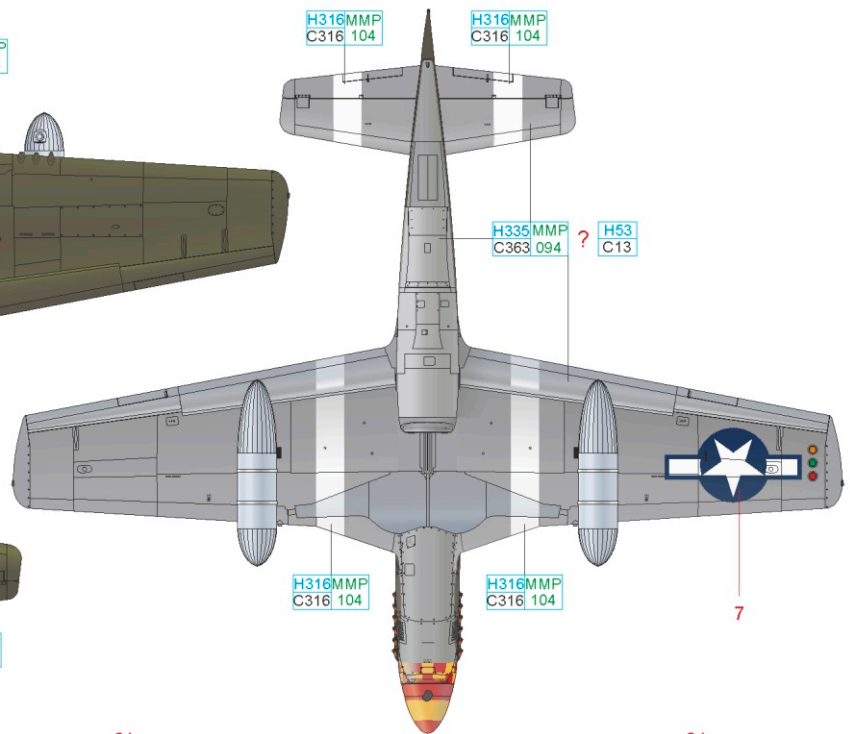
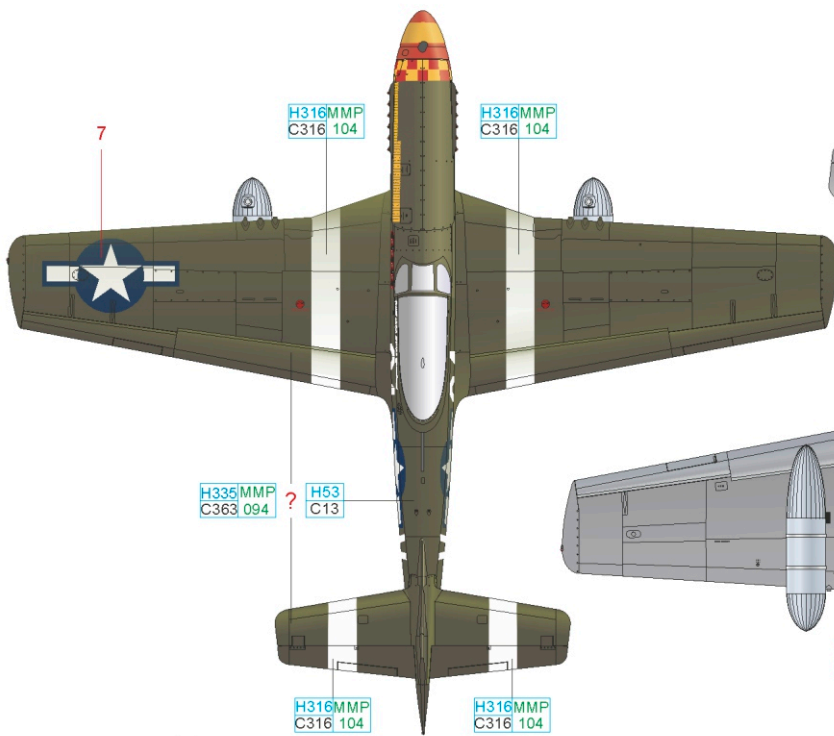

| | | | | | | | |
|----------------------|---------------------|--------|---------------------|--------------------|---------------------|-----------------|---------------------|
| YELLOW | H329MMP C329 041 | RED | H327MMP C327 101 | OLIVE DRAB | H52 MMP C12 091 | DARK GREEN | H330MMP C361 077 |
| SUPER FINE SILVER | SM201 MMC 001 | SILVER | H8 C8 | MEDIUM SEA GRAY | H335MMP C363 094 | NEUTRAL GRAY | H53 C13 |
| | | | | | | WHITE | H316MMP C316 104 |

The birth of 325th Fighter Group is dated in August 1942 when it was activated at Mitchel Field airbase in New York. The training on P-40 aircraft was conducted at Hilsgrove Field airbase in Rhode Island. The unit was transferred to North Africa in the beginning of 1943 and re-equipment to more powerful Thunderbolts took place in the end of the same year. Once the training was completed the transfer to Italy followed. Here, in the ranks of 15th AF, the unit was flying escorts to heavy bombers on their raids over Southern and Central Europe. The entire group was re-equipped with Mustangs in May the following year. Further escort missions of the heavy bombers over Europe followed as early as in June. 325th Fighter Group was disbanded in May 1945. Since the deployment in Africa the 325th FG aircraft were marked with yellow-black checkerboard on the tail surfaces to help with the friend-or-foe identification flying escorts to the bombers who gave them the nickname „Checkertails“. The checkerboard squares on P-51s measured 10 by 10 inches each. Lt. McDaniel had his girlfriend's name (Mary) and his nickname (Mac) painted on the nose of his fighter.

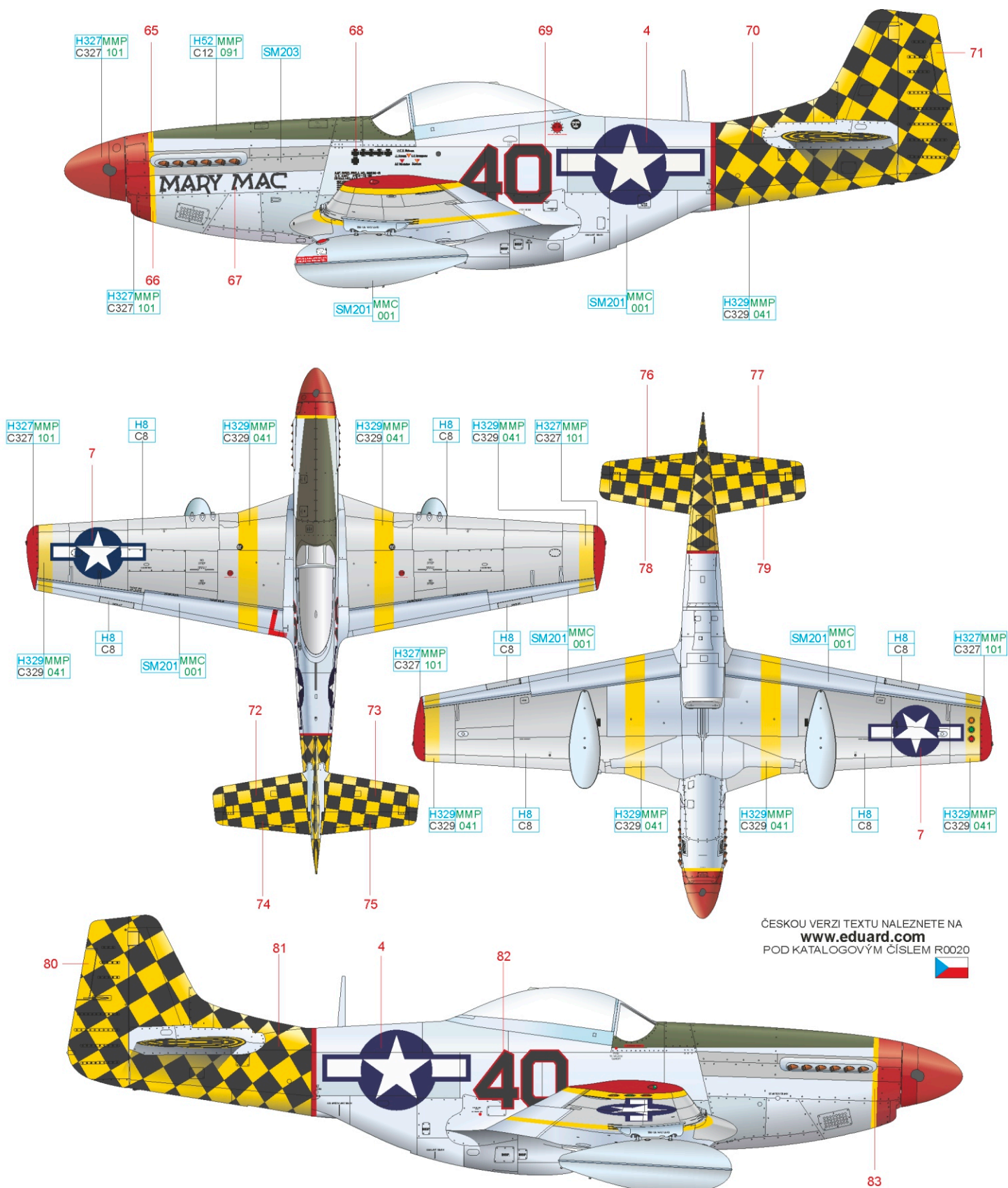

ČESKOU VERZI TEXTU NALEZNETE NA
www.eduard.com
 POD KATALOGOVÝM ČÍSLEM R0020



| | | | | | |
|----------------------|---------------------|---------------|---------------------|---------------|--------------------|
| YELLOW | H329MMP C329 041 | RED | H327MMP C327 101 | OLIVE DRAB | H52 MMP C12 091 |
| SUPER FINE SILVER | SM201 MMC 001 | SUPER IRON | SM203 | SILVER | H8 C8 |

H P-51D-15, 44-15080, flown by Capt. Amos H. Bomberger, 361st FS, 356th FG, 8th AF, Martlesham Heath, United Kingdom, December 1944

356th FG was established on December 8th, 1942 and after necessary training in the south of the United States it was dispatched to Great Britain in fall 1943 and incorporated into 8th AF. It was equipped with P-47 Thunderbolts and the main mission was providing the escort to B-17 and B-24 four engine bombers on their sorties over the Third Reich territory. In November 1944 356th FG squadrons were equipped with P-51D Mustangs flying them until the end of World War Two. Shortly after, on November 10th, 1945, the unit was disbanded. 356th FG aircraft marking was the red fuselage nose with blue diamonds, same colors were applied to the propeller spinners. Capt. Bomberger christened his aircraft Carolyn's Vergeltungswaffe. This word meaning „revenge weapon“ in English was the designation for V-1 flying bombs and V-2 rockets in German propaganda parlance.

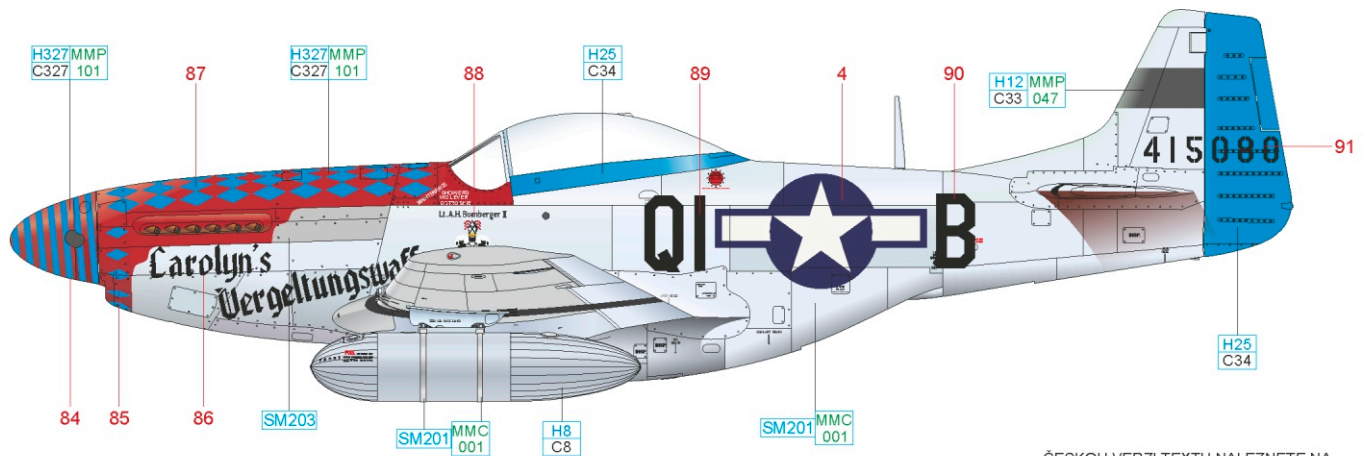

ČESKOU VERZI TEXTU NALEZNETE NA
www.eduard.com
 POD KATALOGOVÝM ČÍSLEM R0020

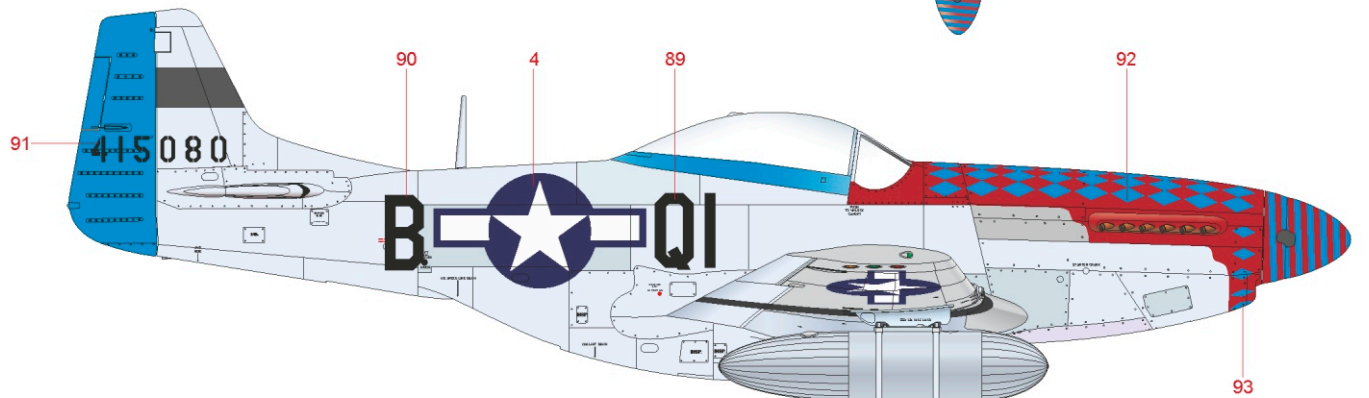
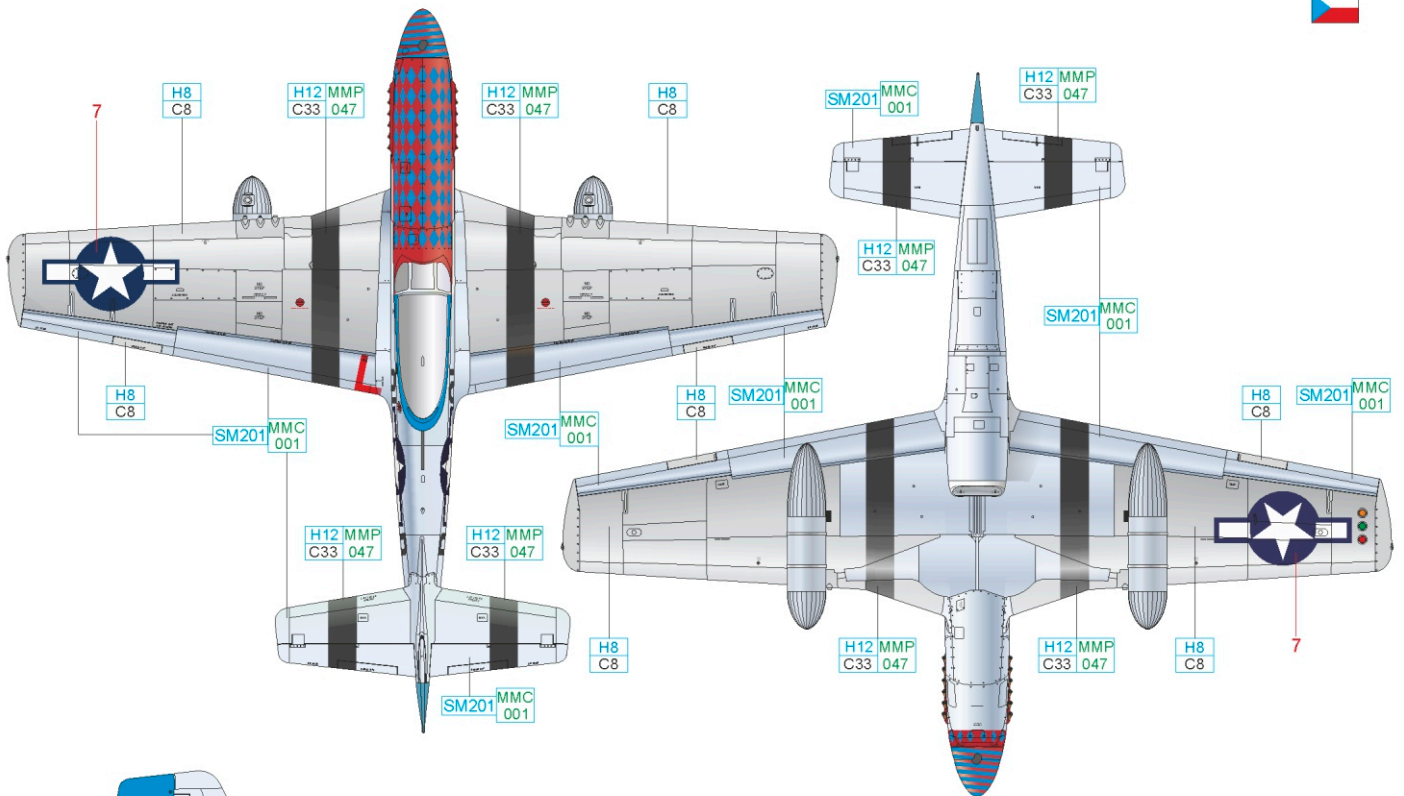

| | | | |
|-------------------|------------------|------------|---------------------|
| BLUE | H25 C34 | RED | H327MMP C327 101 |
| SUPER FINE SILVER | SM201 MMC 001 | SUPER IRON | SM203 |
| | | BLACK | H12 MMP C33 047 |
| | | SILVER | H8 C8 |

P-51D-15, flown by Lt. Charles White, 301st FS, 332nd FG, 15th AF, Ramitelli, Italy, January 1945

332nd FG was established on July 4th, 1942 at Tuskegee Army Air Field in Alabama. The unit possessed special status since the vast majority of its personnel and pilots were American Africans. The training on P-39s and P-40s was being dragged on because the superior officers were reluctant to deploy the unit in the European Theater. In the end it was transferred to 15th Air Force where its primary mission was to neutralize the garrison and airbase on the island of Pantelleria preceding the Sicily landing. After the transfer to Italy, in June 1944, the unit was equipped with P-47 Thunderbolts which after a month were replaced by superior Mustangs flown by the unit till the end of war. The unit was disbanded on October 19th, 1945. 332nd FG aircraft had their tail surfaces painted red for better friend-or-foe recognition on their bombers' escort sorties over the occupied Europe. This gave birth to their nickname Red Tails.

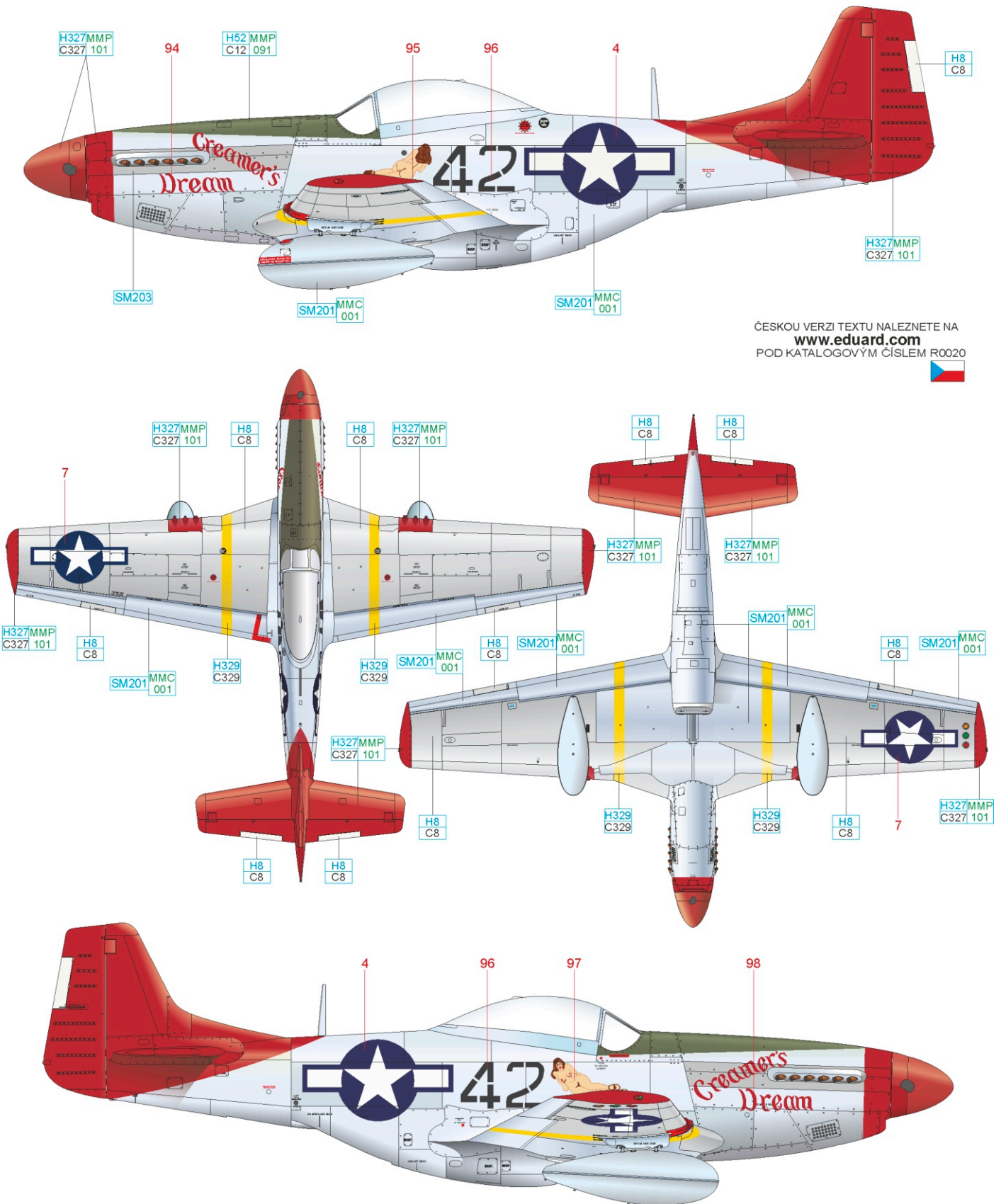

ČESKOU VERZI TEXTU NALEZNETE NA
www.eduard.com
 POD KATALOGOVÝM ČÍSLEM R0020



| | | | | | |
|----------------------|------------------|---------------|--------------------|--------|---------------------|
| YELLOW | H329 C329 | OLIVE DRAB | H52 MMP C12 091 | RED | H327MMP C327 101 |
| SUPER FINE SILVER | SM201 MMC 001 | SUPER IRON | SM203 | SILVER | H8 C8 |

J P-51D-20, 44-64124, flown by Capt. Leroy V. Grosshuesch, 39th FS, 35th FG, 5th AF, Okinawa, August 1945

The 39th FS, initially equipped with the P-39 and P-400, was relocated in the summer of 1942 to undertake defence duties of Port Moresby, New Guinea. Leroy V. Grosshuesch began his combat career with the squadron in November 1943, and a year later was named CO of 39th FS. By that time, the unit was flying the robust P-47 Thunderbolt, with which Grosshuesch would achieve seven kills against the Japanese over the Philippines. For their transition onto the elegant Mustang, the 39th FS moved to Okinawa and from there, flew long range missions to targets on the Japanese island of Kyushu and in Korea. On one of the squadron's last missions on August 12th, 1945, Grosshuesch shot down a JAAF Ki-84. The pictured Mustang sustained heavy damage during the combat, and he flew it only for a short while. The heavy black bands, sometimes in combination with white ones, were standard identifiers of 5th Air Army single engined fighters from the end of 1944. Two blue diagonal bands on the fuselage below the cockpit were used by the Squadron CO. Leroy Grosshuesch served out his command function til the spring of 1946, and it was during the immediate postwar era that one of his Mustangs carried the inscription 'Little Girl', erroneously attributed to Mustang serialied 44-64124 from the summer of 1945.

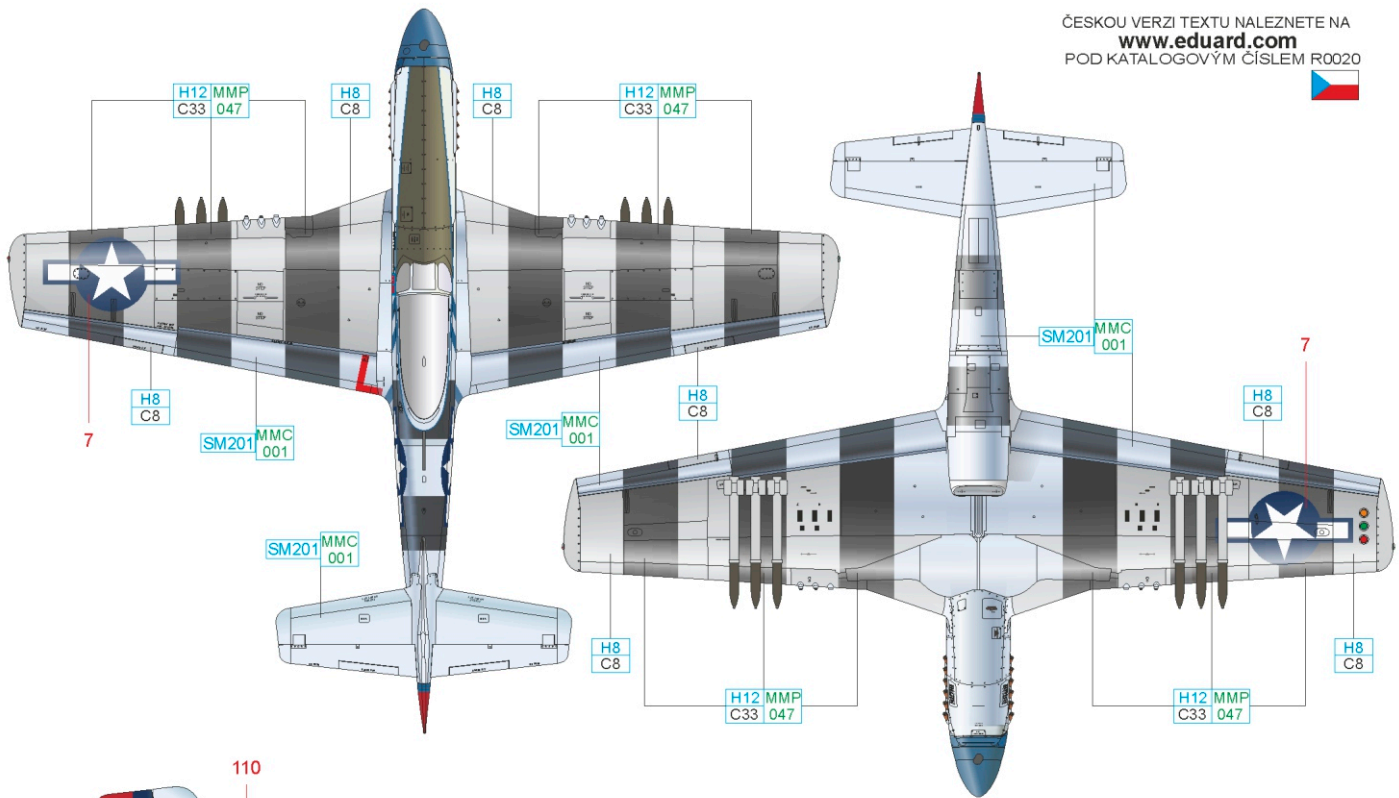
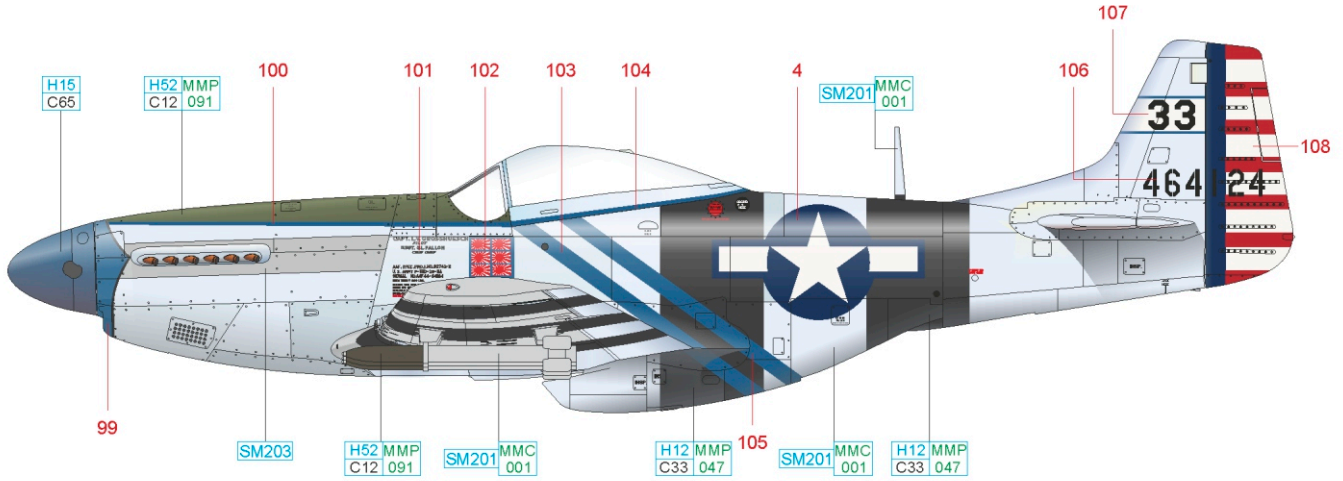

ČESKOU VERZI TEXTU NALEZNETE NA
www.eduard.com
 POD KATALOGOVÝM ČÍSLEM R0020

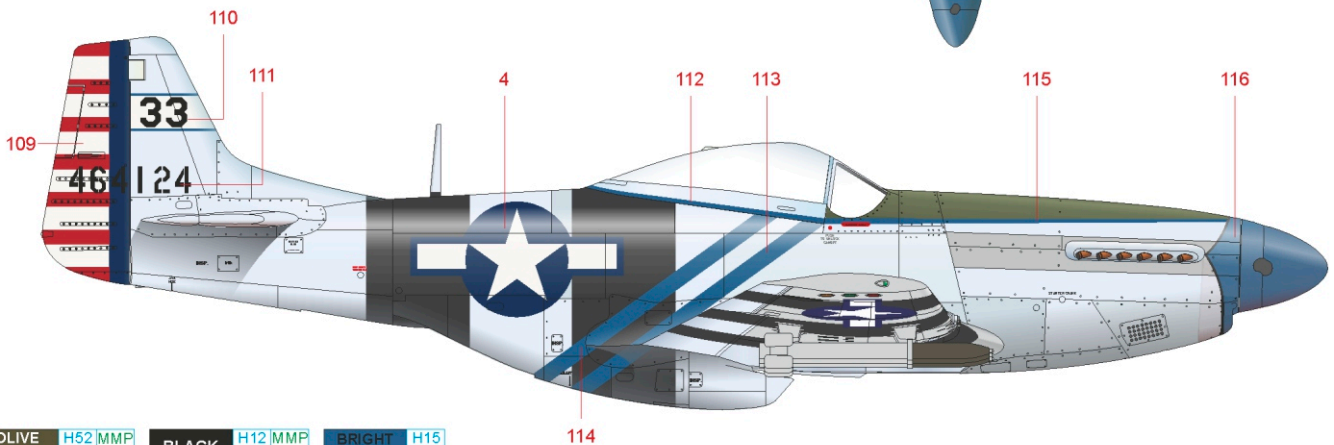

| | | | | | |
|-------------------|-----------------|------------|-----------------|-------------|---------|
| OLIVE DRAB | H52 MMP C12 091 | BLACK | H12 MMP C33 047 | BRIGHT BLUE | H15 C65 |
| SUPER FINE SILVER | SM201 MMC 001 | SUPER IRON | SM203 | SILVER | H8 C8 |

K P-51D-25, 44-72628, flown by Lt. Ralph R. Coltman/ Lt. James E. Coleman, 458th FS, 506th FG, 20th AF, Iwo Jima, July 1945

From its inception in October 1944 at Lakeland Army Airfield in Florida, 506th Fighter Group was equipped with P-51 Mustangs. During the training its pilots were polishing the skills in very long range flights since their mission was escorting the B-29 bombers in the Pacific Theater of Operation. On March 17th, 1945, the ship carrying the unit's personnel anchored at Guam where they received new P-51D versions 20 and 25 which they flew over to Tinian and consequently Iwo Jima from where, starting in May 1945 flew the sorties against Bonin Islands and Japan and also escorts to B-29 bombers on their sorties against Japan. 506th FG aircraft sported colorful tails, either in solid color or in the form of diagonal stripes. Blue indicated 458th FS. The aircraft 44-72628 is attractive thanks to the variety of artwork and inscriptions on its fuselage nose.

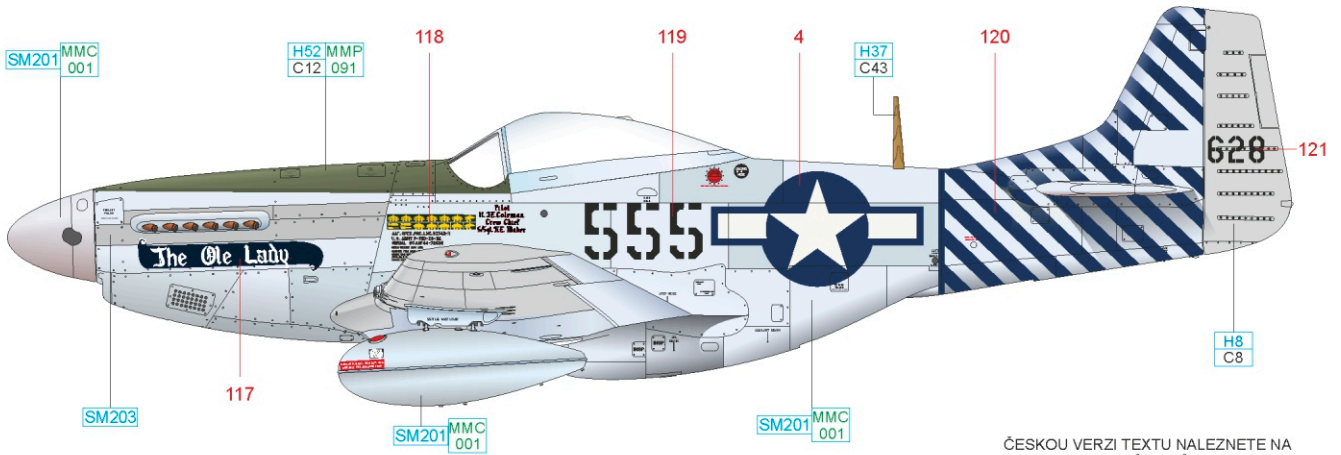

ČESKOU VERZI TEXTU NALEZNETE NA
www.eduard.com
POD KATALOGOVÝM ČÍSLEM R0020

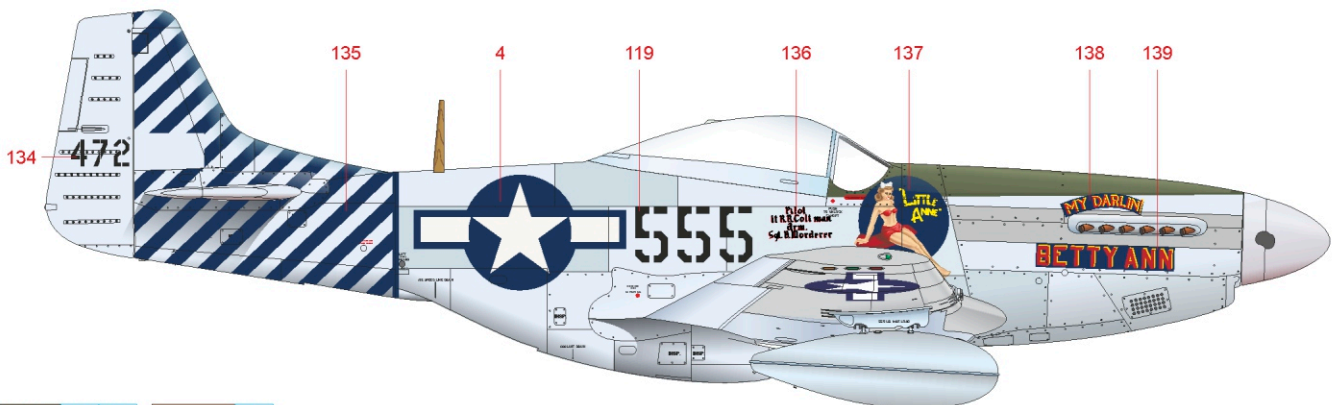
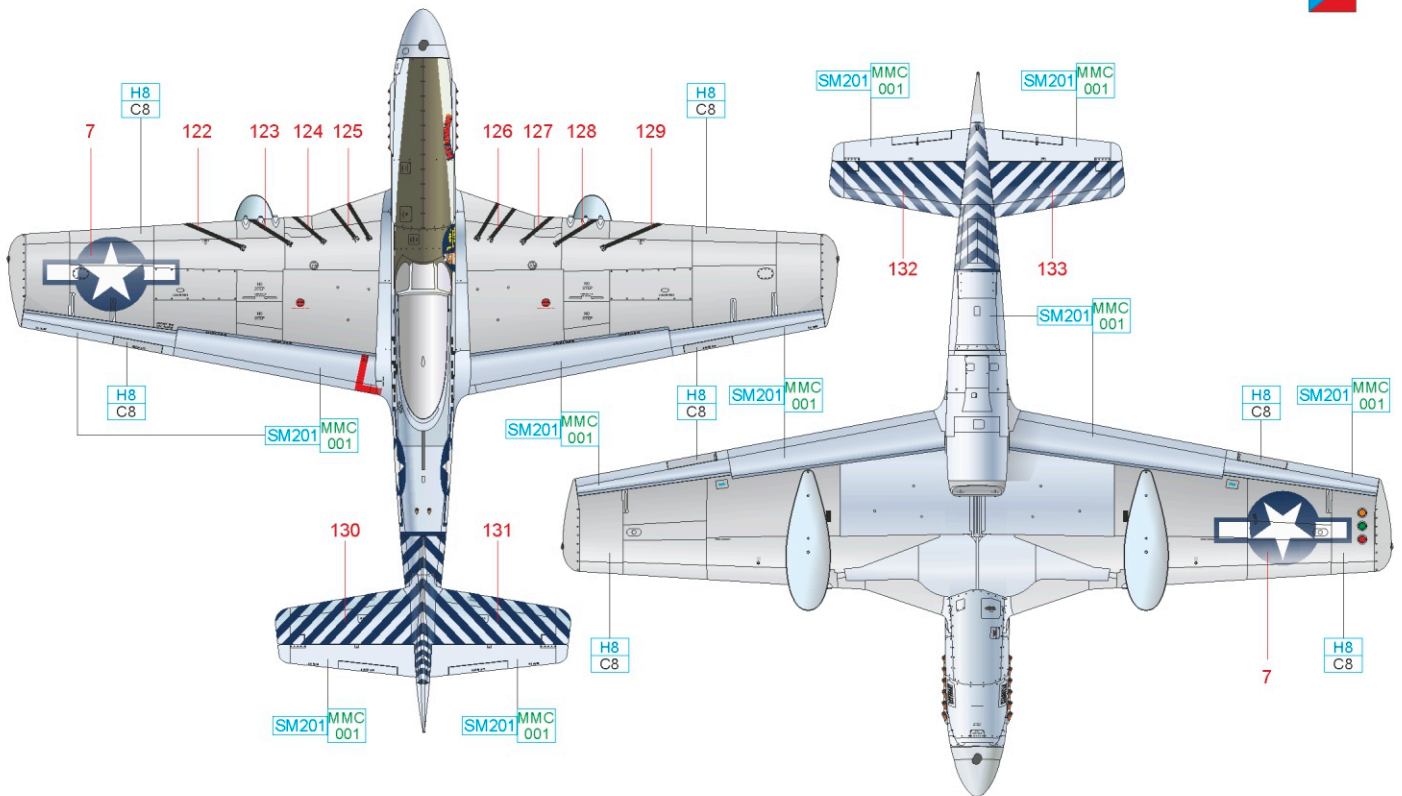

| | | | |
|-------------------|-----------------|------------|---------|
| OLIVE DRAB | H52 MMP C12 091 | WOOD | H37 C43 |
| SUPER FINE SILVER | SM201 MMC 001 | SUPER IRON | SM203 |
| | | SILVER | H8 C8 |

T2nd Lt. William Saks is better known among historians for his Mustang's decoration than his combat achievements and scored enemy aircraft kills. In the ranks of 457th Fighter Squadron he participated in the B-29 bombers' escort sorties which were devastating Japanese islands or in the entire 506th FG Mustang fleet raids against the logistical centers and other military targets in Japan. His fate was sealed on June 1st, 1945 when returning to Iwo Jima he perished together with another eleven pilots of this unit. This day he flew with machine 44-72885. The cause of this tragedy was bad weather. This day is called Black Friday in 506th FG records. 457th FS aircraft tails were sprayed in green color for better recognition during the long range escort flights. T2nd Lt. Saks named his aircraft Enchantress, there was a sparsely-clad girl painted under the windshield inspired by Albert Varga's artwork.

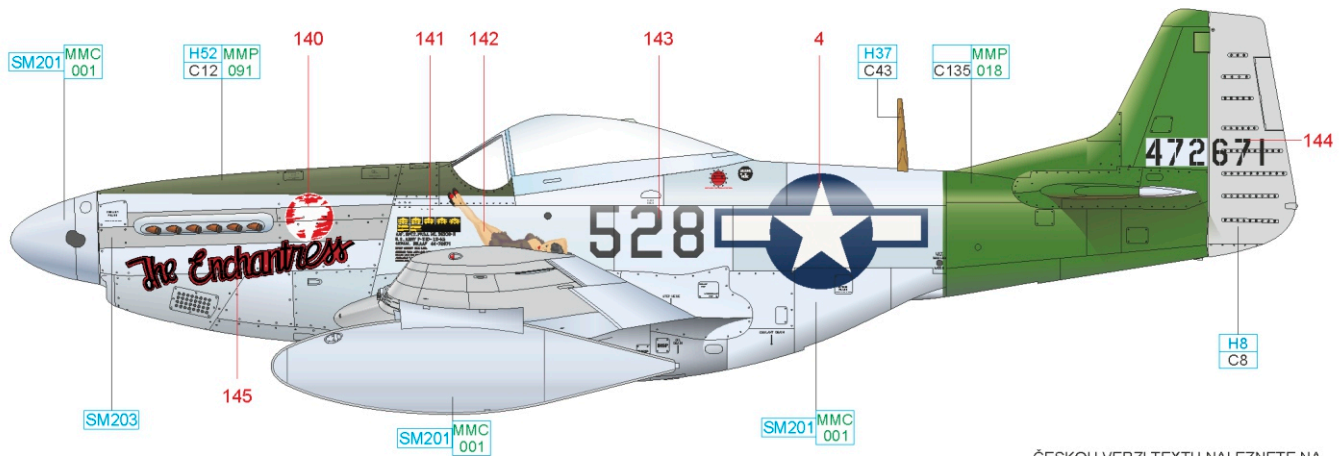

ČESKOU VERZI TEXTU NALEZNETE NA
www.eduard.com
 POD KATALOGOVÝM ČÍSLEM R0020

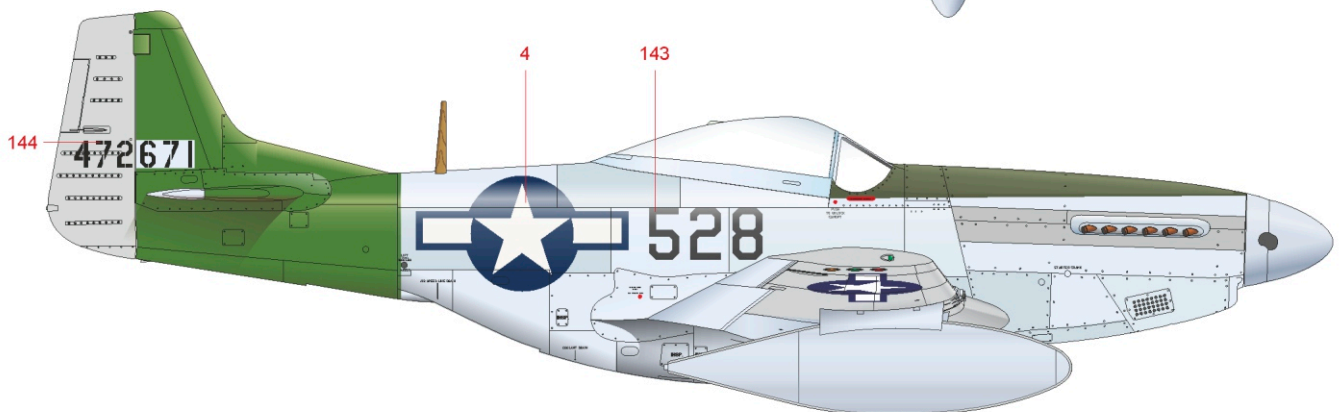
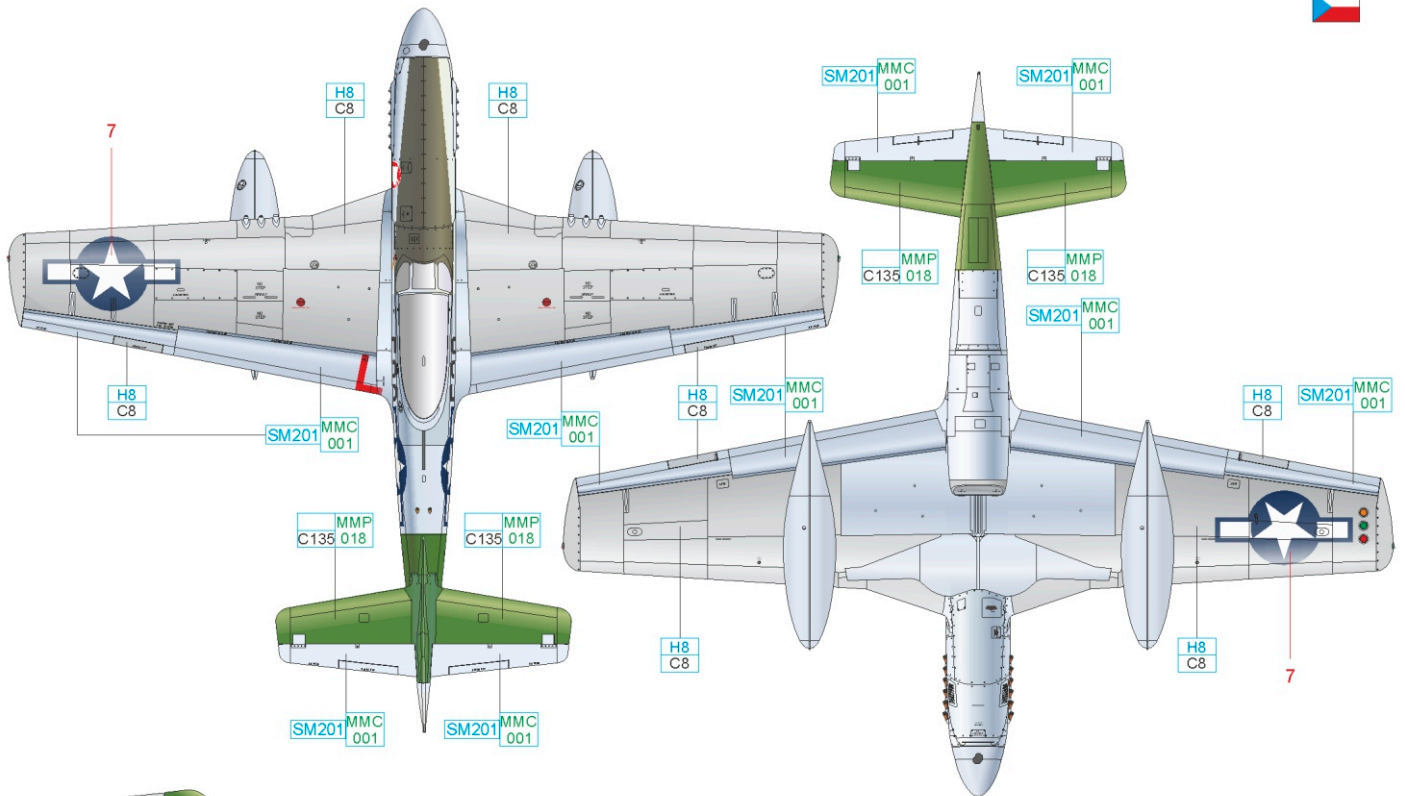

| | | | | | |
|-------------------|-----------------|------------|---------|--------|--------------|
| OLIVE DRAB | H52 MMP C12 091 | WOOD | H37 C43 | GREEN | MMP C135 018 |
| SUPER FINE SILVER | SM201 MMC 001 | SUPER IRON | SM203 | SILVER | H8 C8 |

M Mustang Mk.IVA, KH774, flown by Fl/Lt. Ellis F. Blanchford, No. 112 Squadron RAF, No. 239 Wing RAF, Italy, April 1945

No. 112 Squadron history dates back to World War One period, it had been established in June 1917 at Throwley aerodrome in Kent with the mission to protect London against enemy raids. Before the World War Two outbreak it was sent to Egypt to protect this territory in the case of a conflict. Later it participated in the defense of Greece during the German invasion of the country, battles on the African hot soil and later in Sicily and Italy. During July 1941 the unit received the American P-40 aircraft on which, inspired by Bf-110 aircraft from ZG 76, sharkmouths were painted. This practice lasted until the re-equipment to Mustang Mk.III in June 1944. In February the unit received newer Mustangs Mk.IV which it flew until the end of hostilities. During the World War Two pilots of this unit shot down 206 enemy aircraft and destroyed further 62 on the ground. Mustang camouflaged in British colors of Dark Green and Ocean Gray on the upper and side surfaces sports the sharkmouth on the nose, typical for No. 112 Squadron aircraft. The lower surfaces were painted in Medium Sea Gray.

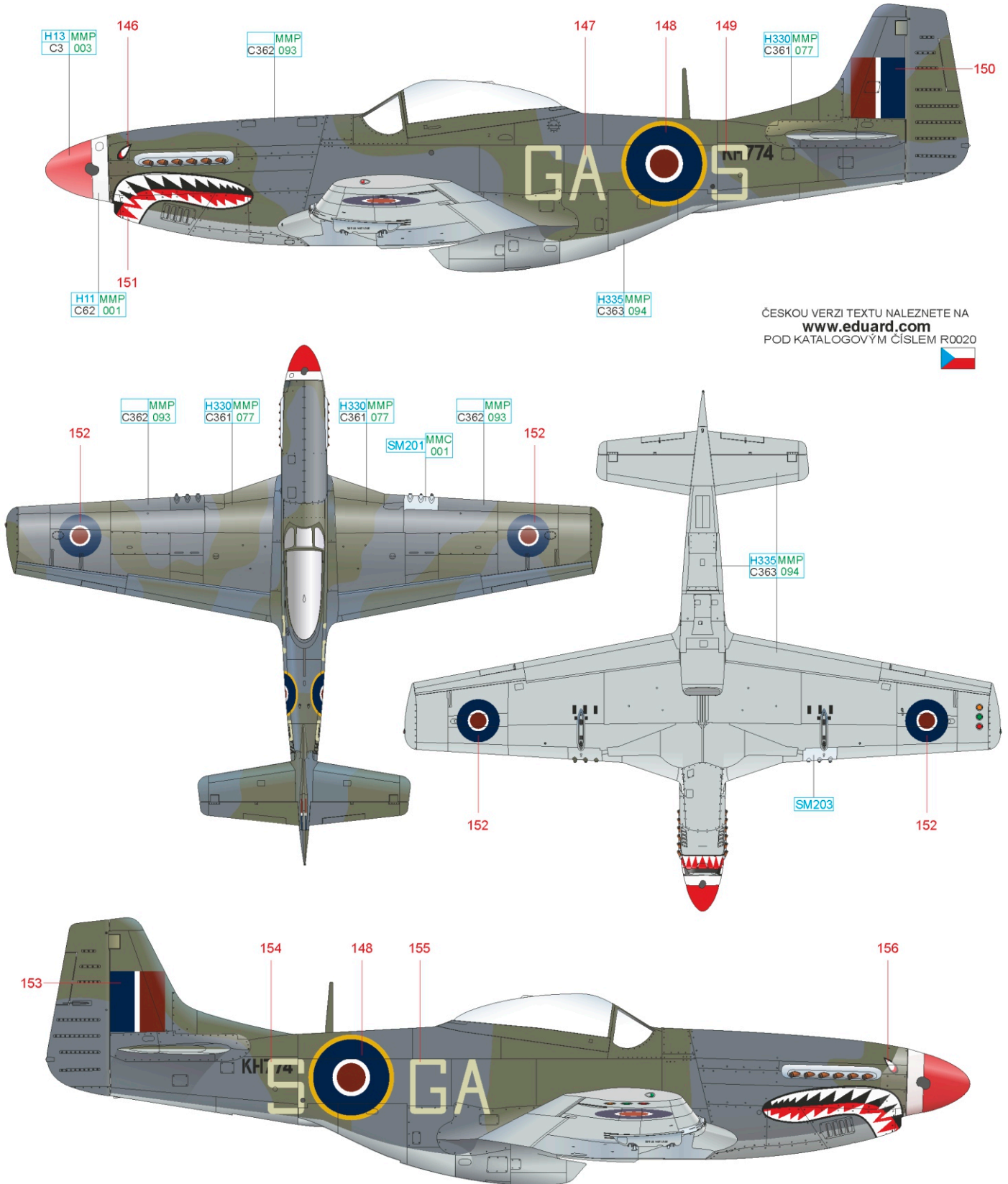

ČESKOU VERZI TEXTU NALEZNETE NA
www.eduard.com
 POD KATALOGOVÝM ČÍSLEM R0020



| | | | | | |
|-----------------|---------------------|-------------------|------------------|------------|---------------------|
| RED | H13 MMP C3 003 | SUPER FINE SILVER | SM201 MMC 001 | WHITE | H11 MMP C62 001 |
| MEDIUM SEA GRAY | H335MMP C363 094 | OCEAN GRAY | MMP C362 093 | DARK GREEN | H330MMP C361 077 |

N Mustang Mk.IVA, KH729, flown by S/Ldr Mitchell Johnston, No. 442 „Caribou“ Squadron RCAF, RAF station Digby, United Kingdom, June 1945

442nd Squadron was activated in 1942 as No. 14 Squadron flying P-40 aircraft with the mission to defend the Canadian western coast against the potential Japanese attack against Canadian territory after the Pearl Harbor attack. During its mission to prepare for the landing on Japanese-occupied island of Kiska, pilots of this unit were flying out of the Alaska airfields. Later it was re-numbered to No. 442 Squadron and dispatched to Great Britain where it flew Mustangs Mk.IV on the long-range sorties escorting heavy bombers on their raids to the targets in Germany and occupied Europe. During World War Two the unit recorded 58 aerial kills and in addition destroyed hundreds of transports utilized by German war machine to move troops or supplies to the battle fields. The last unit's sortie was the Navy force escort during the Norman Islands liberation on May 9th, 1945. The unit was disbanded after the end of war. RAF marked P-51Ks manufactured at Dallas factory in Texas as Mustang Mk.IV. Code letters and unit insignia above British marking on vertical tail surface confirm that the aircraft belonged to No. 442 Squadron RCAF. James E. Storrar logged several flights in this particular airplane.

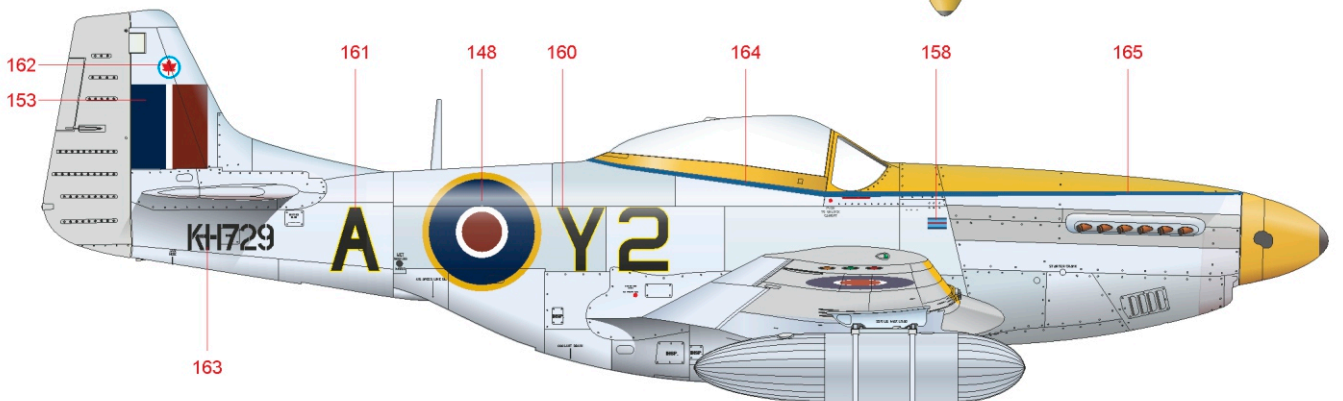
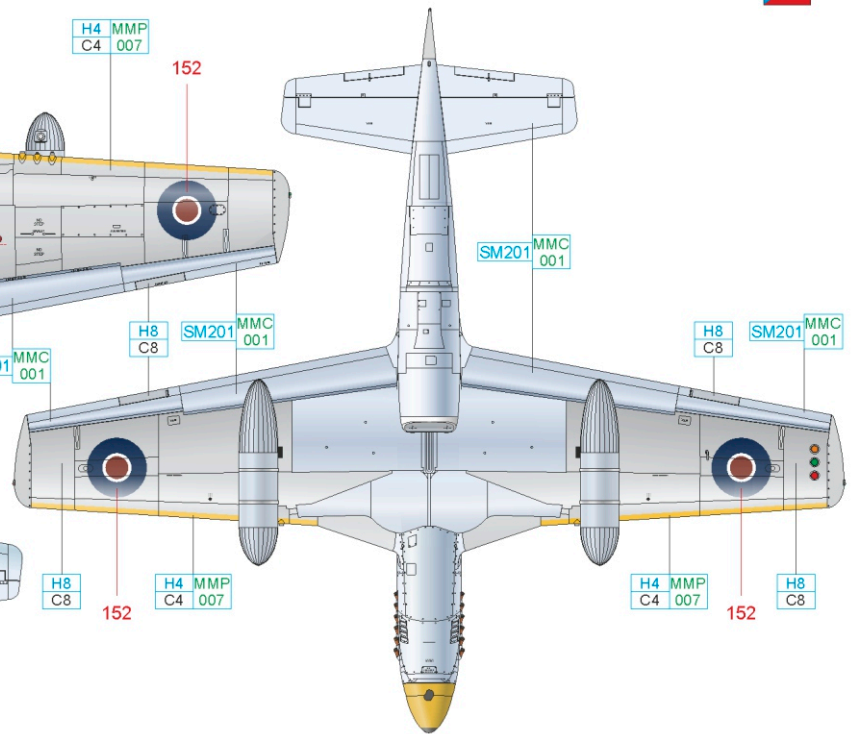
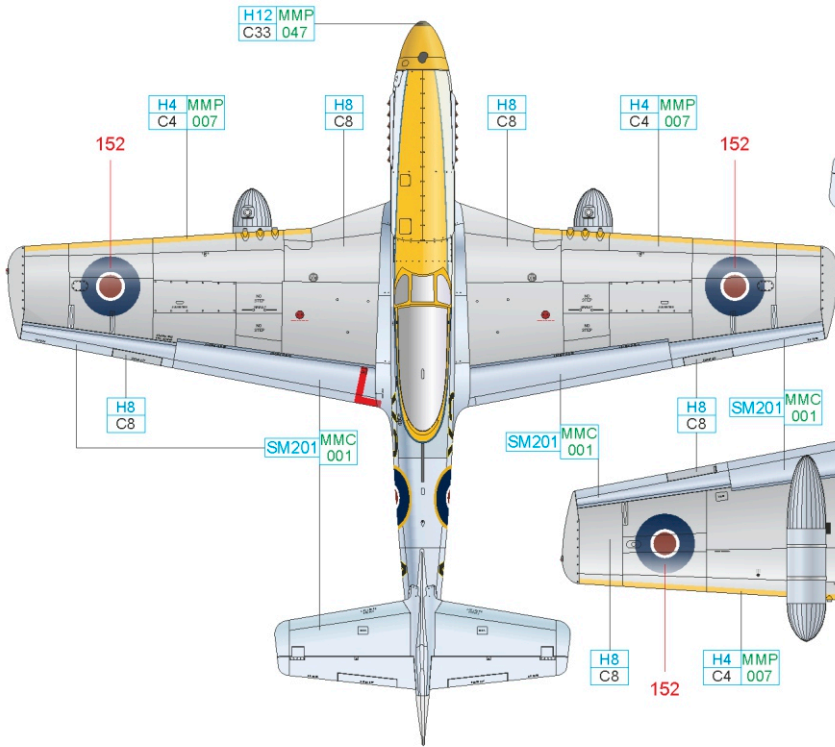
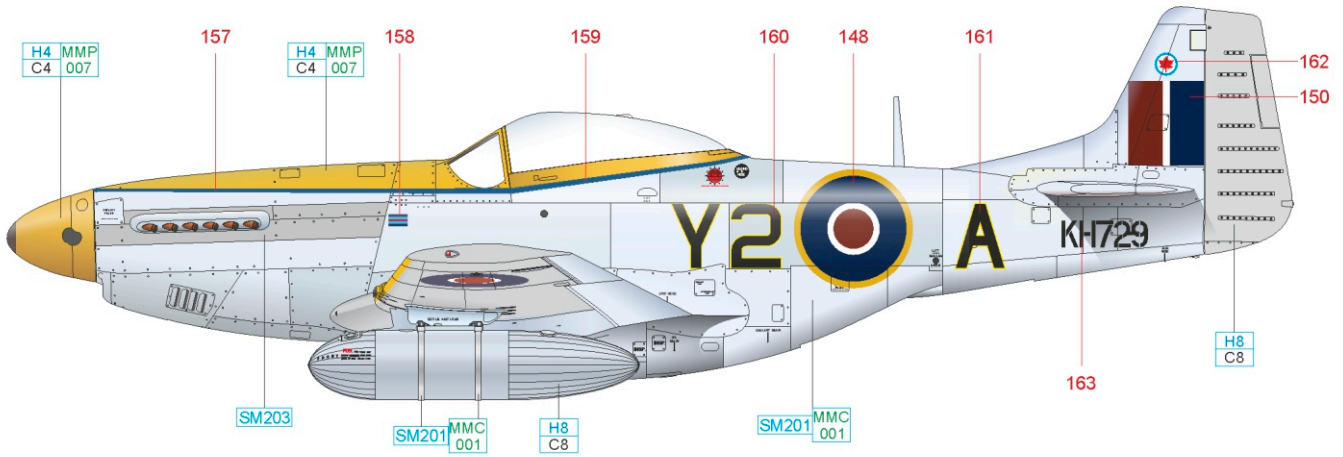

ČESKOU VERZI TEXTU NALEZNETE NA
www.eduard.com
 POD KATALOGOVÝM ČÍSLEM R0020



| | | | |
|-------------------|------------------|------------|--------------------|
| YELLOW | H4 MMP C4 007 | BLACK | H12 MMP C33 047 |
| SUPER FINE SILVER | SM201 MMC 001 | SUPER IRON | SM203 |
| | | SILVER | H8 C8 |

P-51D ALUMINIUM LACQUER PAINTED AREAS

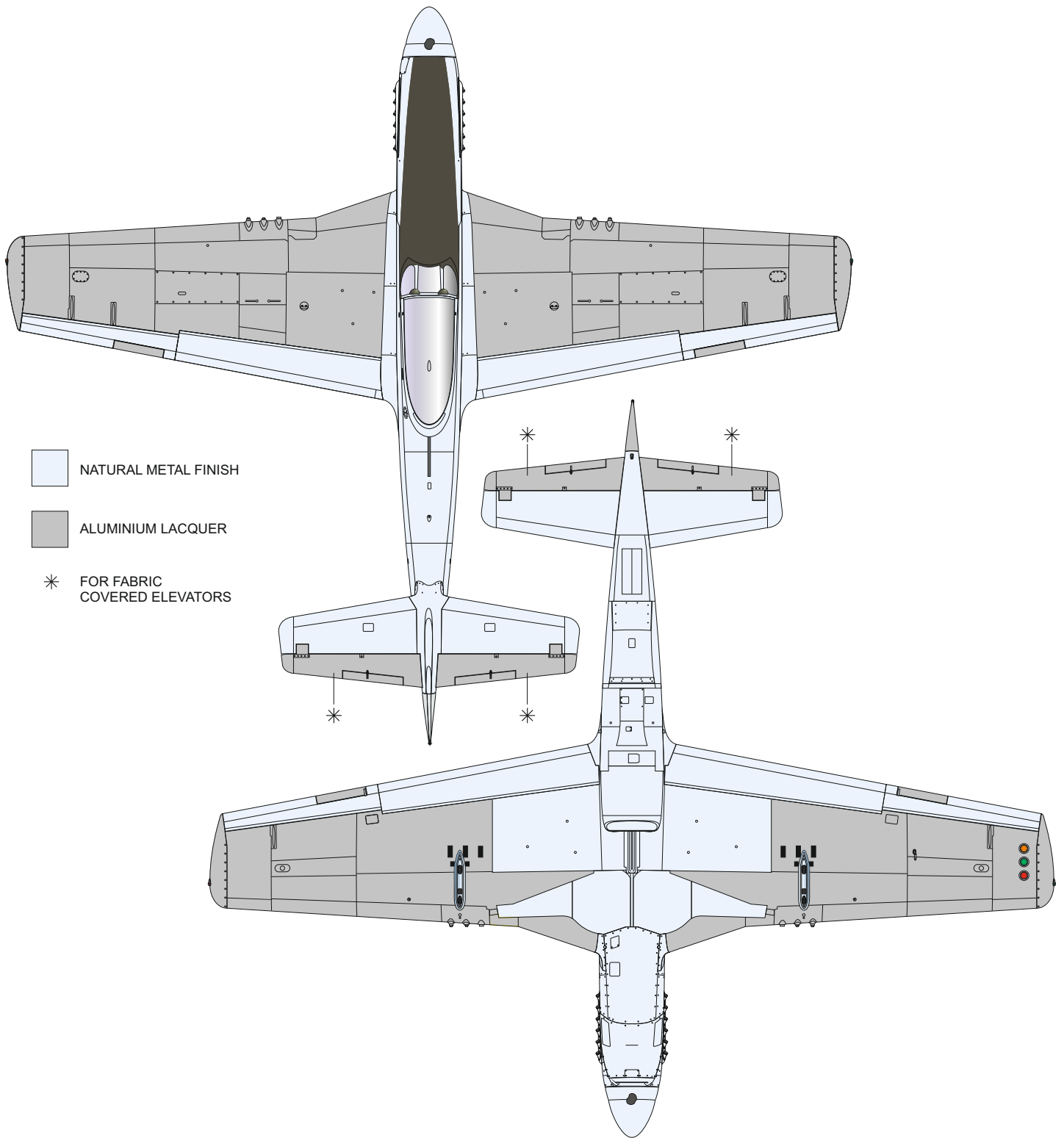

P-51D

STENCILING POSITIONS

MARKING  ONLY

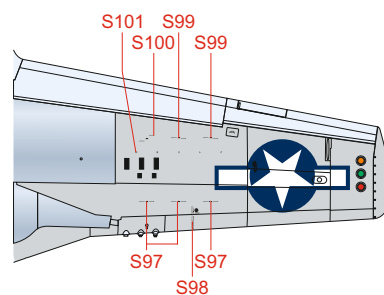
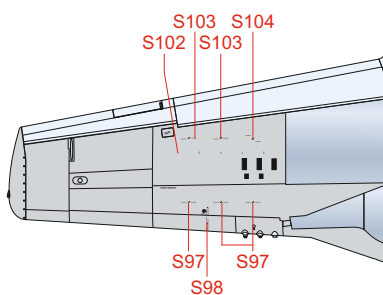

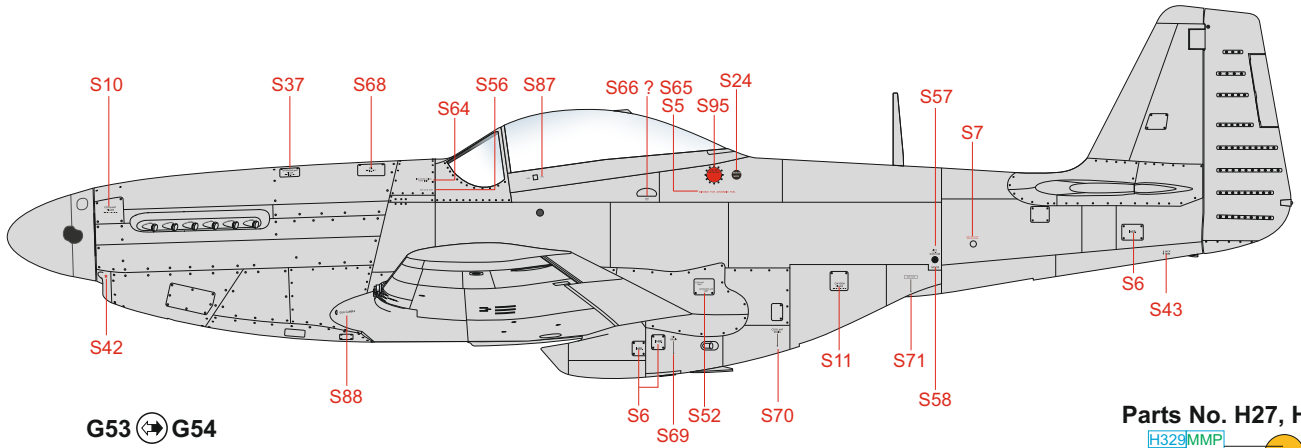

G53 G54

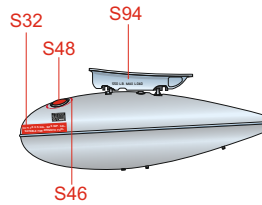
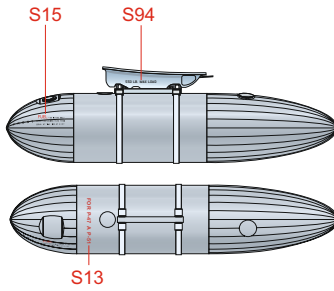
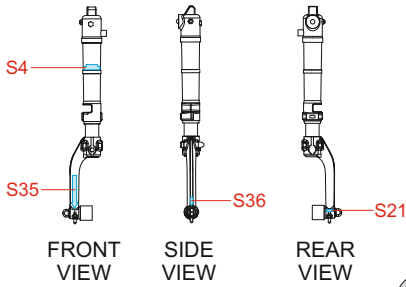

Parts No. H27, H28

H329 MMP
C329 041

H12 MMP
C33 047

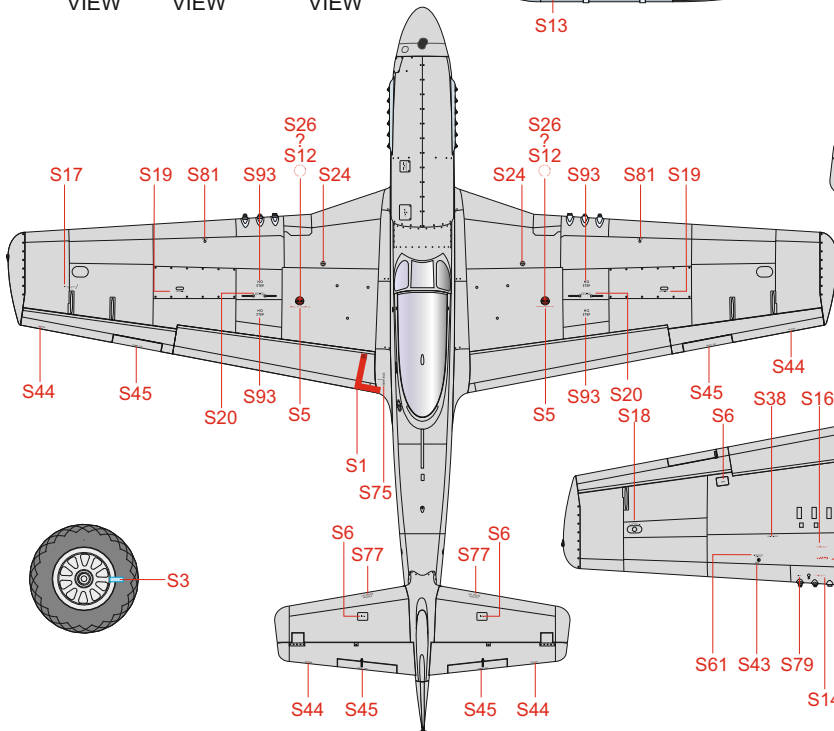
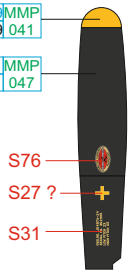

Parts No. H41, H42

H329 MMP
C329 041

H12 MMP
C33 047

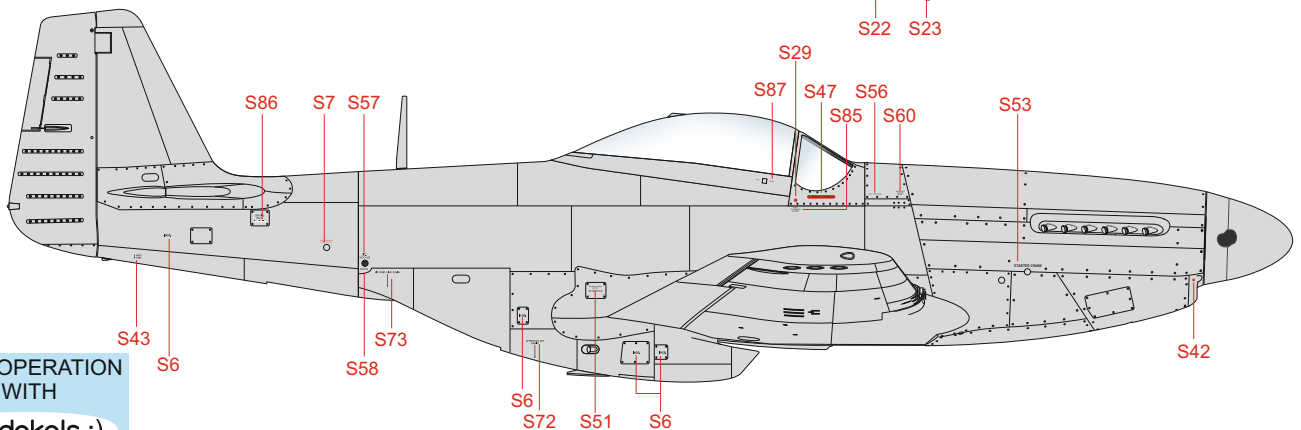
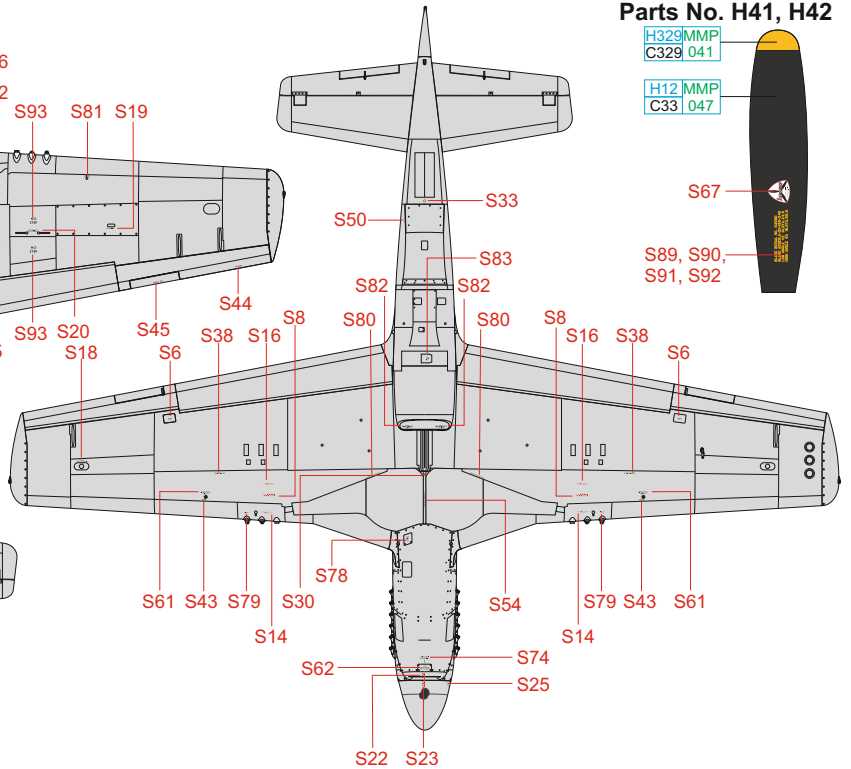
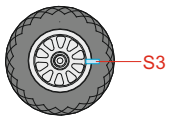
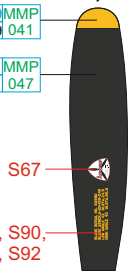

IN COOPERATION WITH
fündekals :)

P-51D

STENCILING POSITIONS

decals No. S37, S62 - on late version only

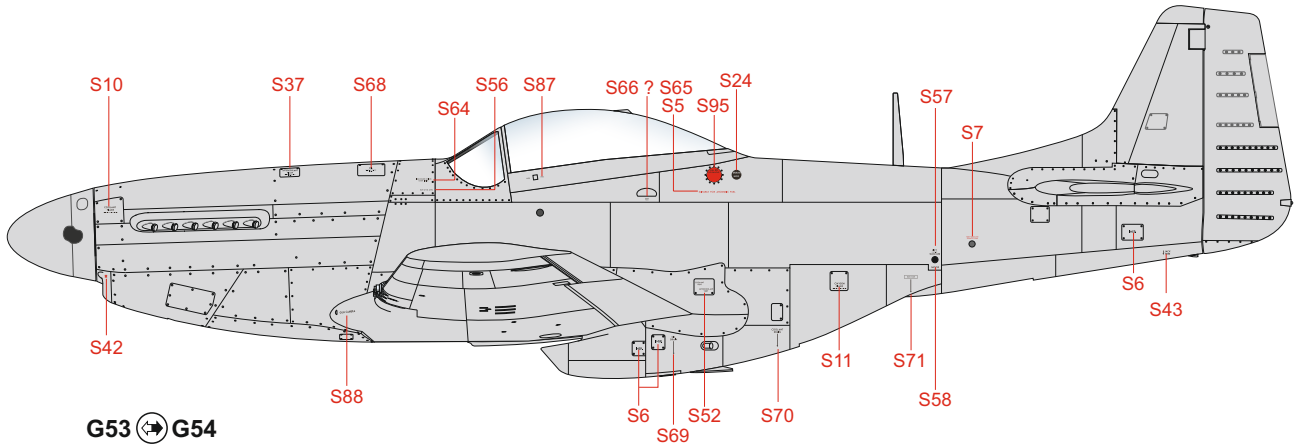

G53 G54

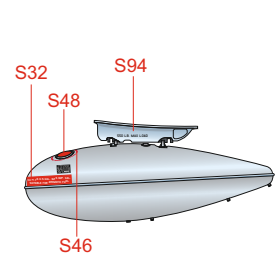
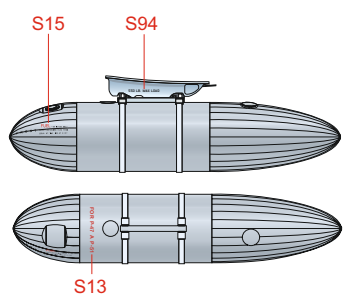
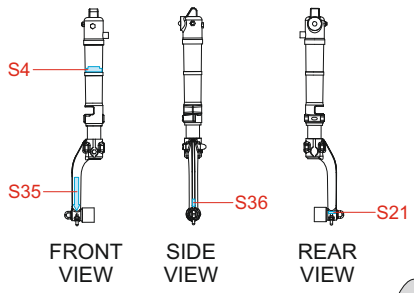

Parts No. H27, H28

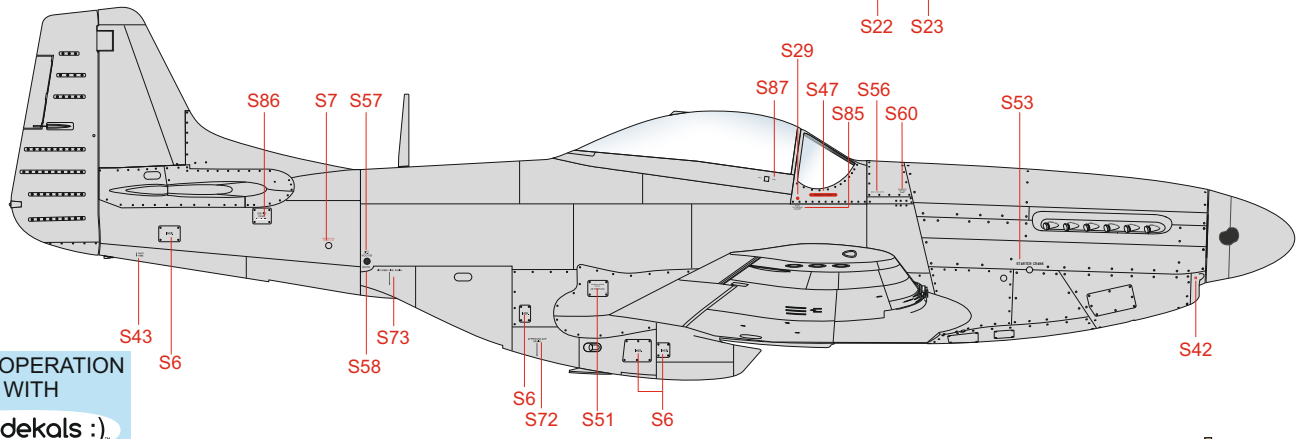
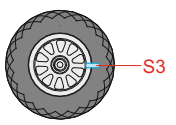
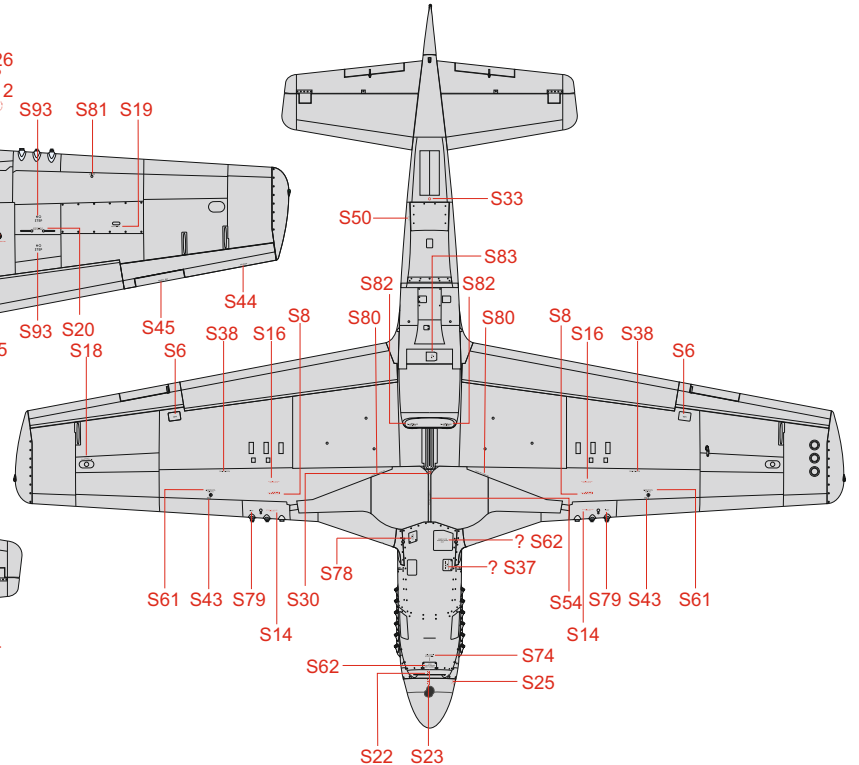
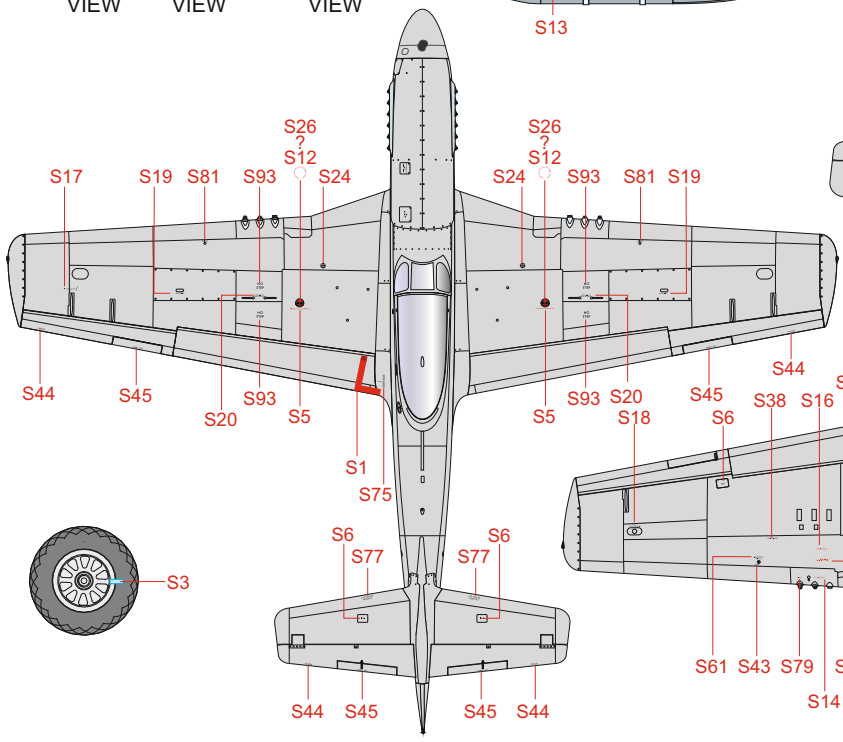
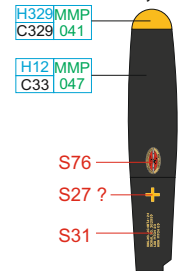

IN COOPERATION WITH
fündekals :)

