

SPS-141 for MiG-21

INTERIOR COLOUR BARVA INTERIÉRU

INTERIOR

60% C34 SKY BLUE + 20% C66 BRIGHT GREEN + 20% C80 COBALT BLUE

INTERIOR

R44

H12 MMP
G331 047
FLAT BLACK

E10

R40

R39

R43

wire
∅ - 0,2 mm
l - 1 mm

R42

R41

SPS-141 for MiG-21

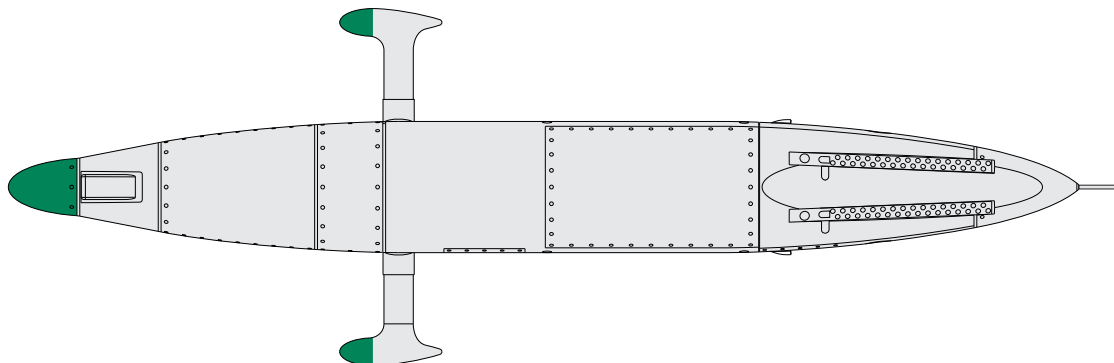
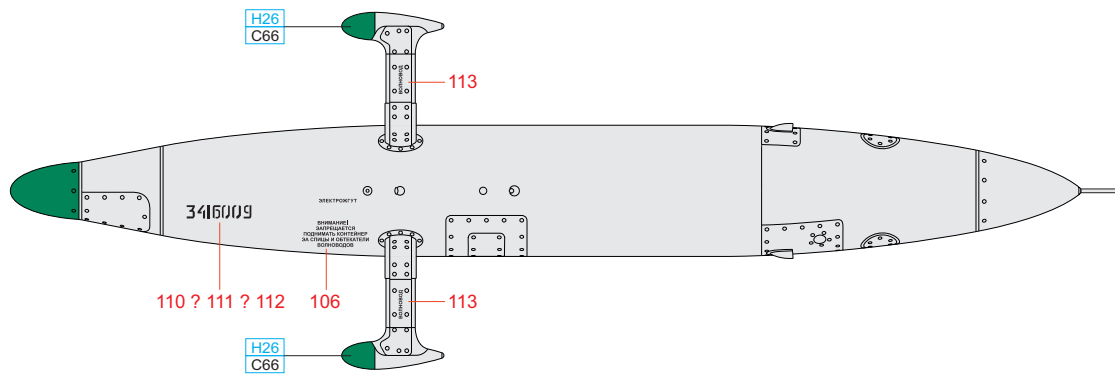
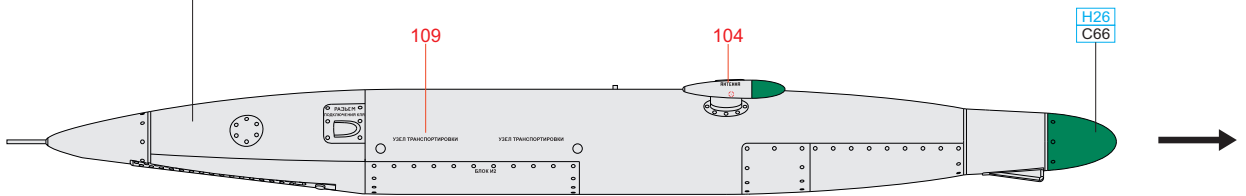
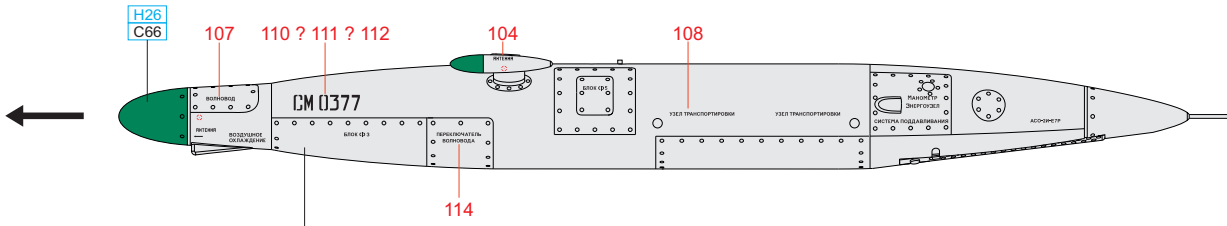
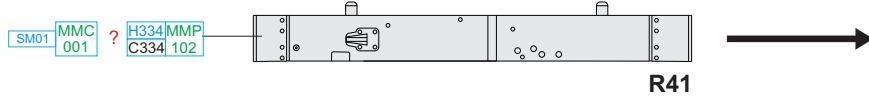
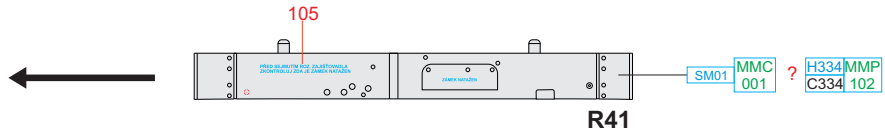

SUPER FINE SILVER SM01 MMC 001 GRAY H334 MMP C334 102 BRIGHT GREEN H26 C66 FLAT BLACK H12 MMP C33 047

eduard

BFC 051 - NAV1

A No. 9714, 1st slp, České Budějovice, Czechoslovakia, 1988/ 1989

This aircraft served with the majority of fighter regiments in the Czechoslovak Air Force. First, it was assigned to the 4th slp (Fighter Air Regiment) in Pardubice (1974-1985), followed by service with the 9th slp in Bechyně (1985) and the 5th slp at Lině. Its ability to carry the SPS-141 ECM pod took it from Planá in České Budějovice to the 3rd Squadron of the 1st slp together with the MiG coded 9709. Between 1989 and 1991 it served with the 8th slp in Brno. From 1991 up to the breakup of Czechoslovakia, it was with the 81st sslt (Independent Fighter Squadron) at Sliač. It was retained by the Czech Air Force after the division of assets between the Czech and Slovak republics. It ended its career with the 82nd sslt at Mošnov and was retired in 1993.

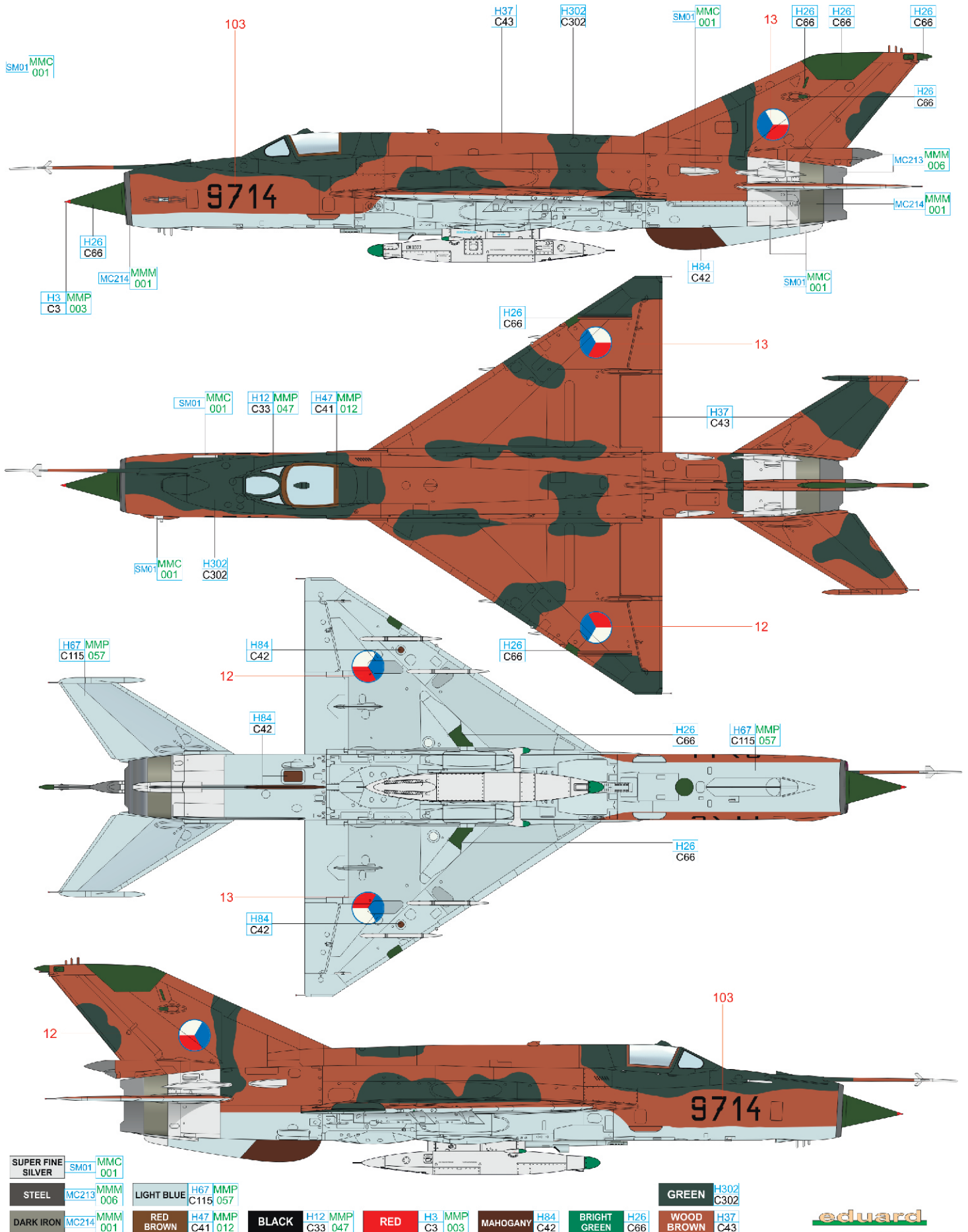

SUPER FINE SILVER	SM01	MMC 001
STEEL	MC213	MMM 006
DARK IRON	MC214	MMM 001
LIGHT BLUE	H67	MMP C115 057
RED BROWN	H47	MMP C41 012
BLACK	H12	MMP C33 047

RED	H3	MMP C3 003
MAHOGANY	H84	C42
BRIGHT GREEN	H26	C66
WOOD BROWN	H37	C43
GREEN	H302	C302

B No. 4312, 9th slp, Bechyň, Czechoslovakia, 1980s

The SPS-141 ECM pod was carried in the Czechoslovak Air Force by the MiG-21MF and MA using special pylon adaptors under the fuselage. This equipment was designed to jam the Hawk (MIM-23) anti-aircraft defence system and allow four-ship formations of MiG-21s to penetrate into enemy held territory. After serving with the 4th slp (Fighter Air Regiment) at Pardubice, aircraft coded 4312 was transferred to the 9th slp in 1973. Through the mid eighties, the plane went through an upgrade that allowed for the carriage of the SPS-141 pod. The splitting of assets between the newly formed Czech and Slovak republics allocated the aircraft to the Slovak side. It was retired in 1997. Throughout its entire service career, the aircraft carried no camouflage scheme.

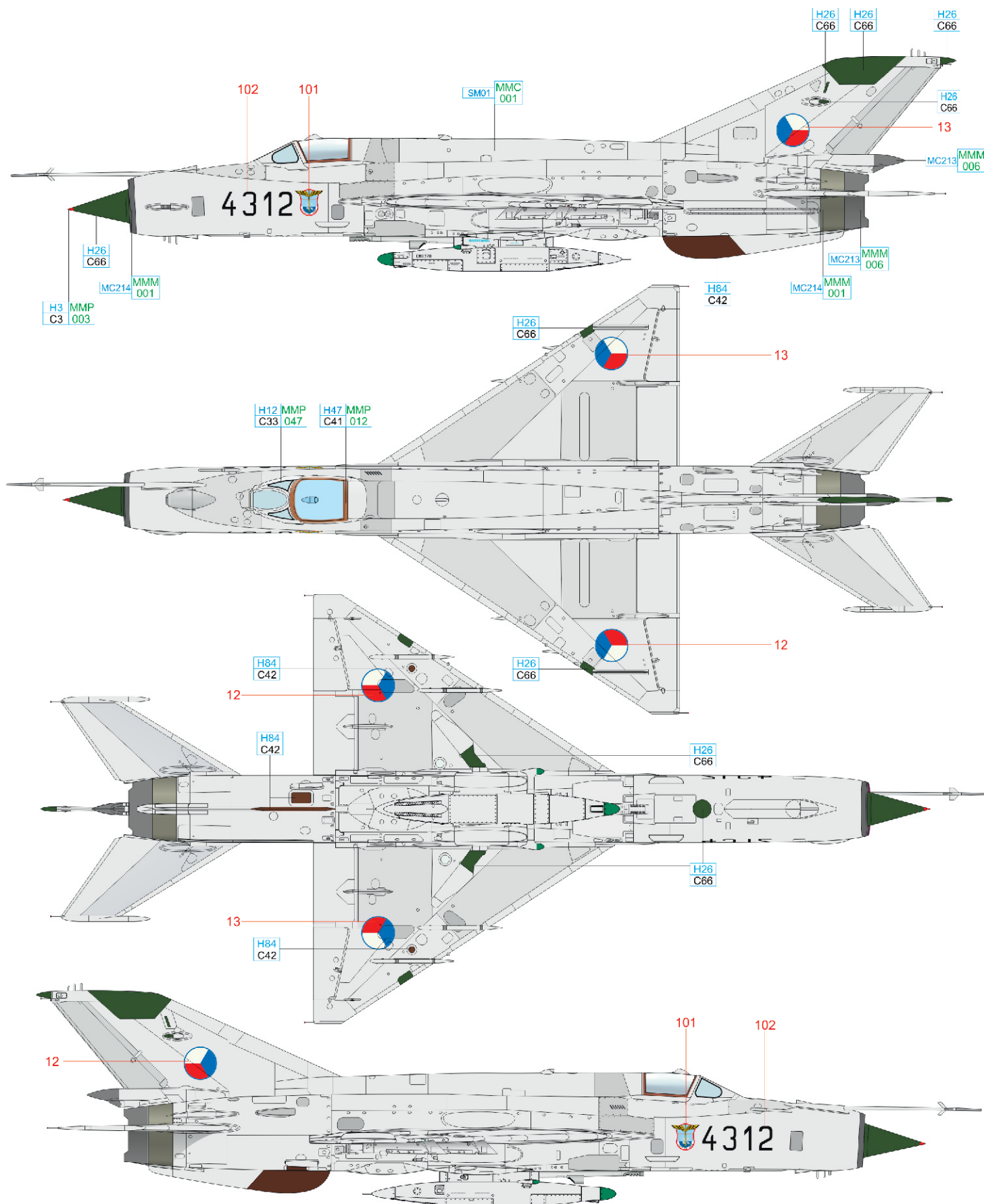

STEEL	MC213	MMM 006	SUPER FINE SILVER	SM01	MMC 001										
DARK IRON	MC214	MMM 001	RED BROWN	H47 MMP C41	O12	MAHOGANY	H84 C42	BRIGHT GREEN	H26 C66	RED	H3 C3	MMP 003	BLACK	H12 MMP C33	O47