



DUAL COMBO!



intro

The story of the Tempest is nothing more than an attempt to address the shortcomings of Hawker Typhoon, which prevented it from being a successful fighter. The main problem of the Typhoon was the thick wing with NACA 22 profile, offering lot of inner space for fuel and armament, but building drag rapidly with rising speed. Not surprisingly was the wing at the core of the changes on the way to the new fighter. The resulting design was originally supposed to retain the Typhoon name as the Mark II, but it became obvious, the result would be a new plane, so the name was changed to the Tempest, following the traditional path of Hawker to use the "wind" names for its fighters.

Series of changes

The new wing was 5 in (12,7 cm) thinner at the root and also the planform changed in comparison with Typhoon wing to more elliptical shape. As the new wing did not offer enough space for fuel, additional 76 gal (288 l) fuel tank had to be installed in the fuselage. The space for it was found between the firewall and the oil tank, but, consequently, it was necessary to move the engine forward by 21 in (53,4 cm). Due to that, the tail surfaces, both the stabilizer as well as elevator, had to be enlarged, also the undercarriage was rebuilt. So, yes, it was a new plane, although it kept the Typhoon engine, which was a very complex issue by itself. With quite ambitious goals regarding the performance of Tempest, new units were considered instead of troubled Napier Sabre II powering the Typhoon. But the things went different way...

Back to the roots

Early contract was placed for two prototypes based on the Typhoon airframes powered by Sabre IV, but due to delays, only the HM599 was fitted with it, while HM595 used old Sabre II. The two prototypes also differed in radiator layout as the HM595 retained the distinctive chin radiator of Typhoon, while HM599 undergo radical change as Sydney Camm, Hawker chief designer, wanted to streamline the design. The radiator moved to the leading edge of the inner wing sections on both sides and the sleek nose got some resemblance to the Spitfire. The wing-mounted radiators layout worked well aerodynamically, but the Sabre IV evinced multiple problems and also the complexity of the wing assembly with integrated radiators was of some concern.

There were only two other units powerful enough for use with the Tempest instead of Sabre IV: the R&R Griffon and radial Bristol Centaurus IV. As the new name Tempest was definitely chosen, different marks were assigned to each engine variant and four more prototypes were ordered. The Mk.I was to be powered by the Sabre IV (HM599), the Mk.II by the Centaurus IV (LA602 and LA607), the Mk.III by the R&R Griffon IIB (LA610) and the Mk.IV by the Griffon 61 (LA614). Finally, the Mk.V (HM595) used slightly improved version of the Sabre II (IIB) producing 2,400 hp (1790 kW), thus 200 hp (147 kW) more than previous version. Although it was meant as a stopgap solution until Sabre IV engines would be available, it finally emerged as the main variant of the Tempest, because Centaurus was too late, Sabre Mk.IV still troubled by glitches and integration of the Griffon into the Typhoon airframe proved to be more demanding than expected. So Mk.III ended with first and only prototype, while Mk.IV was never built.

Legend is born

The HM595 prototype with Sabre II flew for the first time on September 2nd, 1942, fitted with car door canopy, as the bubble canopy was in development at the time. Streamlined HM599 with Sabre IV performed its maiden flight on February 24th, 1943. It was reasonably faster than HM595, but the solution of problems would take too much time. The easiest way to get the Tempest into the service was to proceed with Mk.V.

The first production Tempest Mk.V made its maiden flight on June 21st, 1943, already fitted with bubble canopy. Armed with four 20 mm Hispano Mk.II cannon (200 rounds per barrel) achieved a top speed of 432 mph (695 km/h) at 18,400 feet (5,600 m), up to 45 mph (72 km/h) more than Bf 109 of Fw 190 (depending on mark). After the first production batch, the Hispano Mk.V cannons were installed, differentiating it from the first batch by barrels fully covered by the wing.

The first squadron to receive Tempests was No. 486 in January 1944. Together with No. 3 Squadron it became operational in April 1944. With addition of No. 56 Squadron the first Tempest Wing was formed at Newchurch, Kent, under the command of W/Cdr Roland Prosper „Bee“ Beamont.

Fighting everything

After the period of operations over the France following the D-Day, the Tempest Wing was tasked to fight the V-1 Flying Bombs travelling low at speed of some 400 mph (640 km/h). The Tempest Mk.V was never effective high level fighter due to the nature of its engine, but at the middle and low levels was superior to virtually everything. And some 640 destroyed V-1s during the short period between June and August 1944 speak by themselves, as the rest of RAF scored some 160 of them during the period.

After the V-1 bombing campaign ceased, the Tempest Squadrons returned to the common tasks. At the time, seven Tempest squadrons were flying air-to-air combats and claimed 240 kills (some 20 of them Me 262 jets). Most successful Tempest ace, D. C. Fairbanks (US) recorded 11 kills flying Mk.V „Terror of Rheine“. Second with nine kills came W. E. Schrader (NZ) with nine and J. J. Payton with six kills emerged as third overall. The most famous Tempest Pilot the Free French Pierre Clostermann added four kills to his tally of 11 (some sources state 18 kills, the precise number is unknown).

Tempest was formidable fighter, fast, tough, with powerful weapons. Thanks to the excellent low altitude performance, the strafing attacks were also quite common, usually during the „search and destroy“ rides. Apart of cannons, the provision of two 1000 lb (450 kg) bombs or eight 60 lb (27 kg) rockets added to the destructive force.

To the end of an era

Two more variants of the Tempest would enter production later on, but both were too late to see WW II service. The Tempest Mk.II powered by the Centaurus V used some experience gained by examining the engine cowling of captured Fw 190s. The Tempest VI used the Sabre V engine, and was used only by five RAF squadrons based in the Middle East. Of the Tempest Mk.V 1,401 were produced. After the war Tempest V continued in service with British Air Force of Occupation (BAFO) squadrons until replaced by Tempest Mk.II.

ATTENTION



UPOZORNĚNÍ



ACHTUNG



ATTENTION



注意



Carefully read instruction sheet before assembling. When you use glue or paint, do not use near open flame and use in well ventilated room. Keep out of reach of small children. Children must not be allowed to suck any part, or pull vinyl bag over the head.



Před započítím stavby si pečlivě prostudujte stavební návod. Při používání barev a lepidla pracujte v dobře větrané místnosti. Lepidla ani barvy nepoužívejte v blízkosti otevřeného ohně. Model není určen malým dětem, mohlo by dojít k požití drobných dílů.

INSTRUCTION SIGNS * INSTR. SYMBOLS * INSTRUKTION SINNBILDEN * SYMBOLES * 記号の説明

OPTIONAL
VOLBABEND
OHNOUTSAND
BROUSITOPEN HOLE
VYVRTAT OTVORSYMETRICAL ASSEMBLY
SYMETRICKÁ MONTÁŽREMOVE
ODŘÍZNOUTREVERSE SIDE
OTOČITAPPLY EDUARD MASK
AND PAINT
POUŽIT EDUARD MASK
NABARVIT

PARTS



DÍLY



TEILE



PIÈCES



部品

PLASTIC PARTS

A> 2 pcs.

82120 A

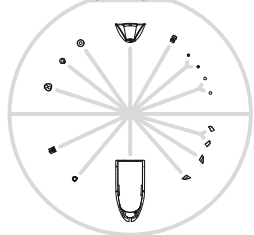

B> 2 pcs.

82120 B

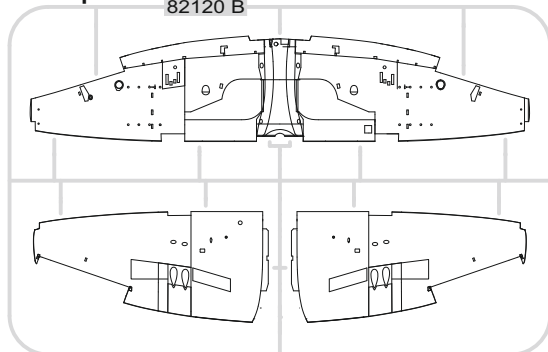

C> 2 pcs.

82120 C

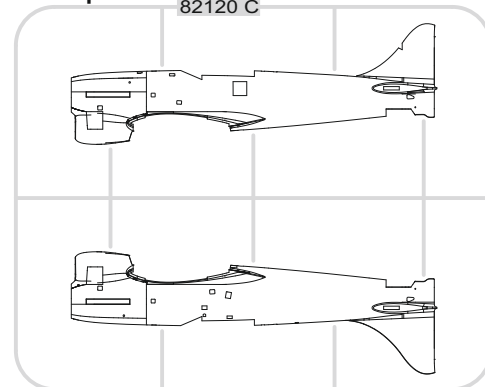

D> 2 pcs.

82120 D

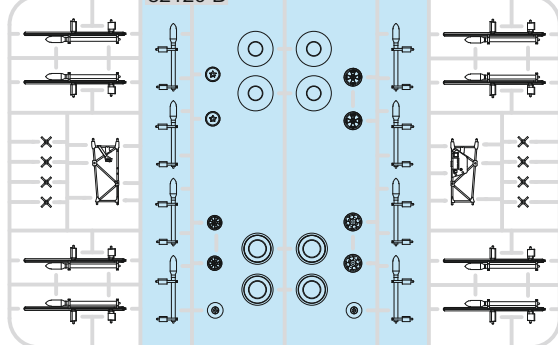

E> 2 pcs.

82120 E

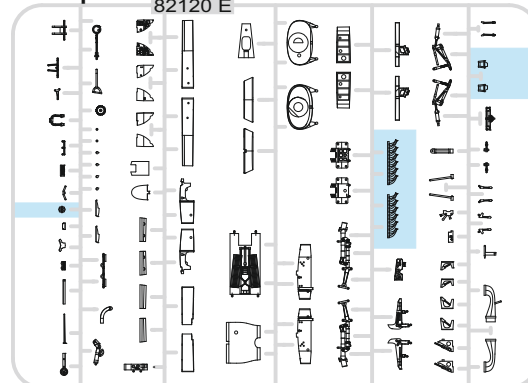
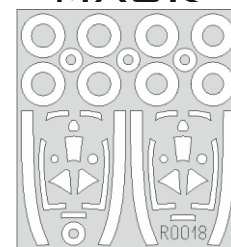
eduard
MASK

F> 2 pcs.

82120 F

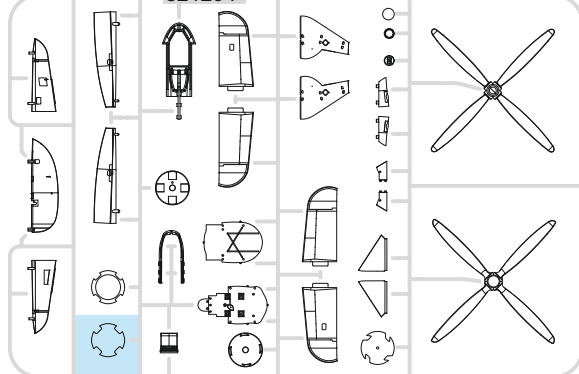

G> 2 pcs.

82120 G

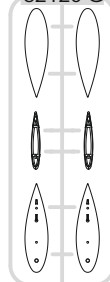
eduard
BRASSIN RP - RESIN PARTS

R1 4 pcs.

R2 2 pcs.

R3 2 pcs.

R4

R5

R161

R162

PE - PHOTO ETCHED DETAIL PARTS



-Parts not for use. -Teile werden nicht verwendet. -Pièces à ne pas utiliser. -Tyto díly nepoužívejte při stavbě. - 使用しない部品

COLOURS



BARVY



FARBEN



PEINTURE



色

GSI Creos (GUNZE)		MISSION MODELS	
AQUEOUS	Mr.COLOR	PAINTS	
H3	C3	MMP-003	RED
H4	C4	MMP-007	YELLOW
H6	C6	MMP-004	GREEN
H8	C8		SILVER
H11	C62	MMP-001	FLAT WHITE
H12	C33	MMP-047	FLAT BLACK
H52	C12	MMP-091	OLIVE DRAB
H74	C368	MMP-080	SKY
H77	C137	MMP-040	TIRE BLACK
H90	C47		CLEAR RED
H94	C138		CLEAR GREEN

GSI Creos (GUNZE)		MISSION MODELS	
AQUEOUS	Mr.COLOR	PAINTS	
H330	C361	MMP-077	DARK GREEN
H335	C363	MMP-094	MEDIUM SEAGRAY
	C159	MMP-006	SUPER SILVER
	C362		OCEAN GRAY
	C364	MMP-079	AIRCRAFT GRAY-GREEN
Mr.METAL COLOR		METALLICS	
MC214		MMM-001	DARK IRON
MC218		MMM-003	ALUMINIUM
Mr.COLOR SUPER METALLIC		METALLICS	
SM01		MMC-001	SUPER CHROME

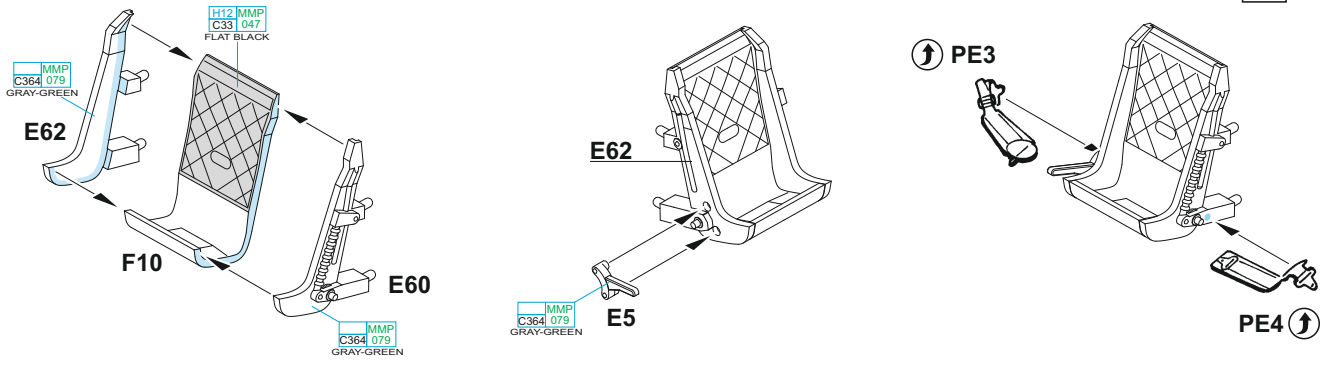
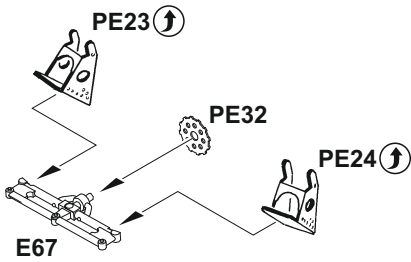
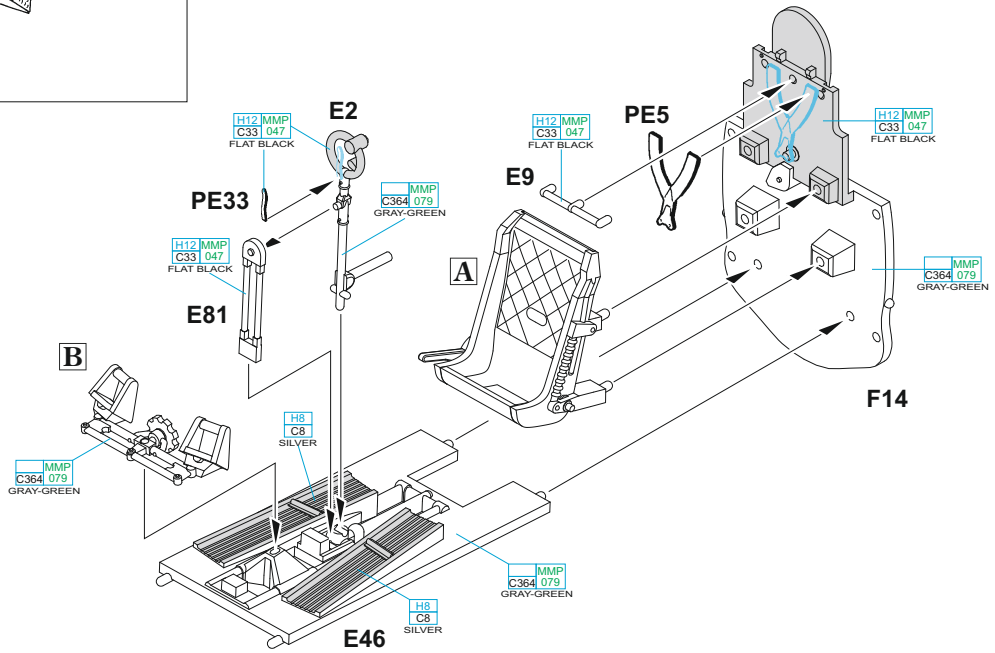
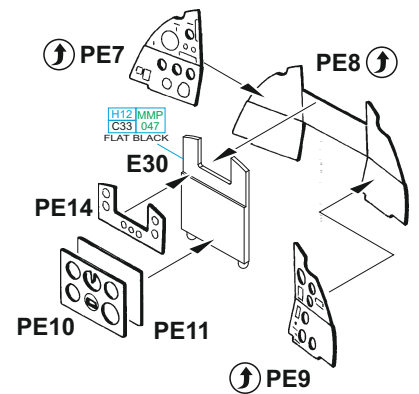
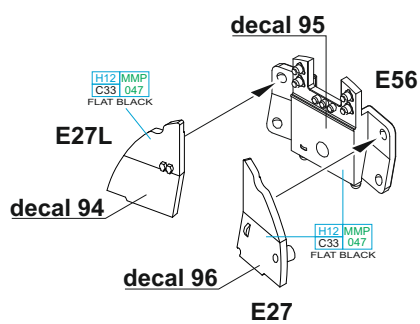
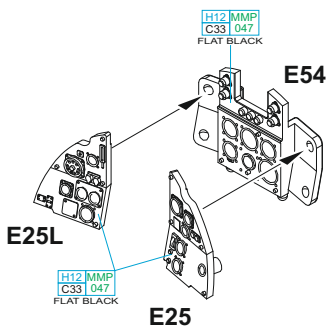
A**B****C****D**

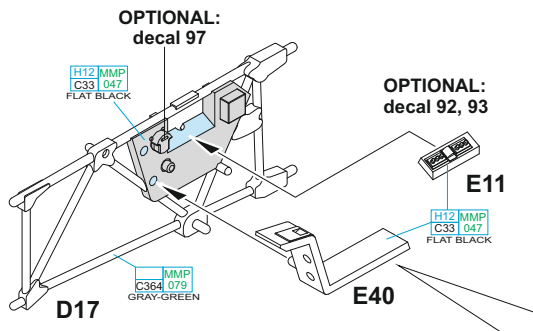
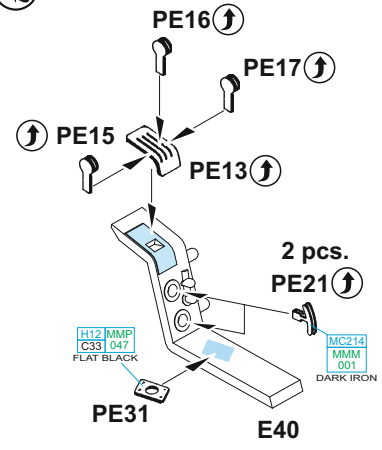
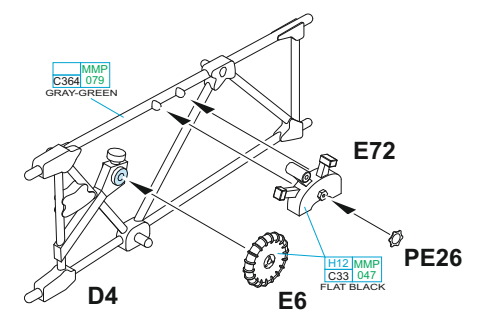
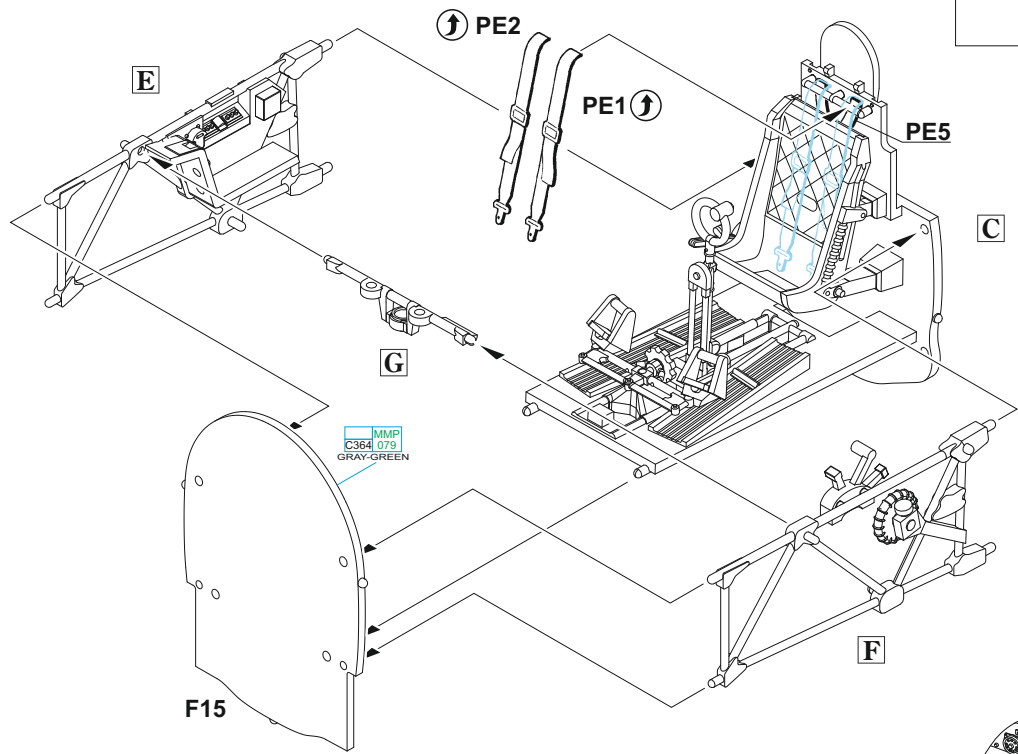
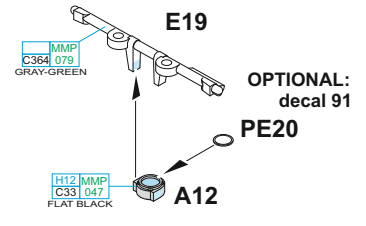
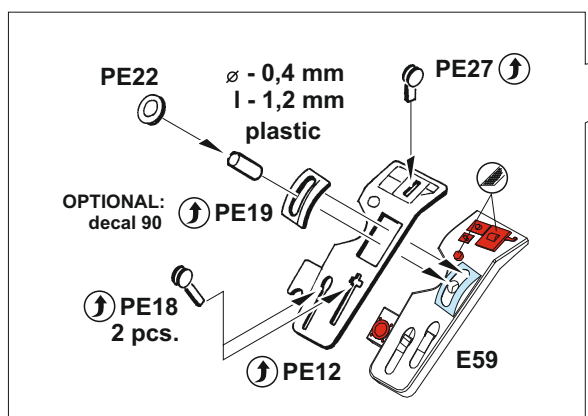
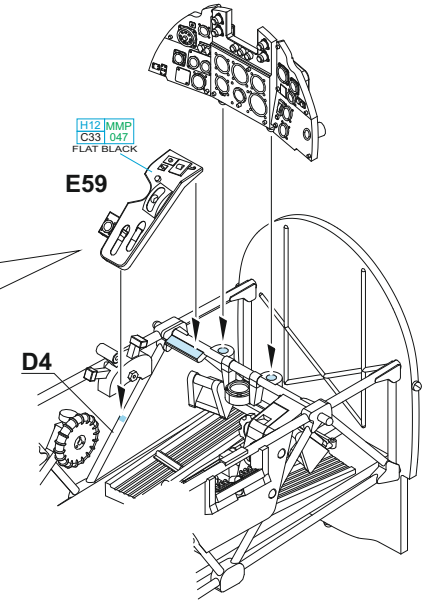
E**F****F****H****G****D**

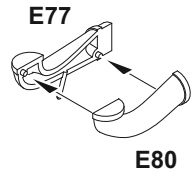
I

MMP
C364 079
GRAY-GREEN

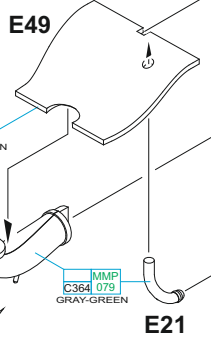

MMP
C364 079
GRAY-GREEN

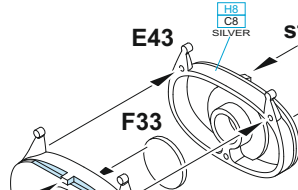
E21

H8
C8
SILVER

step 1

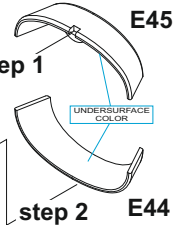

step 2

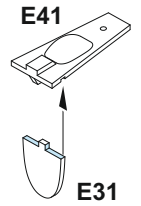
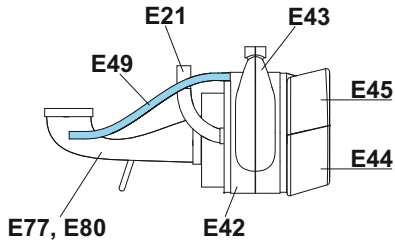
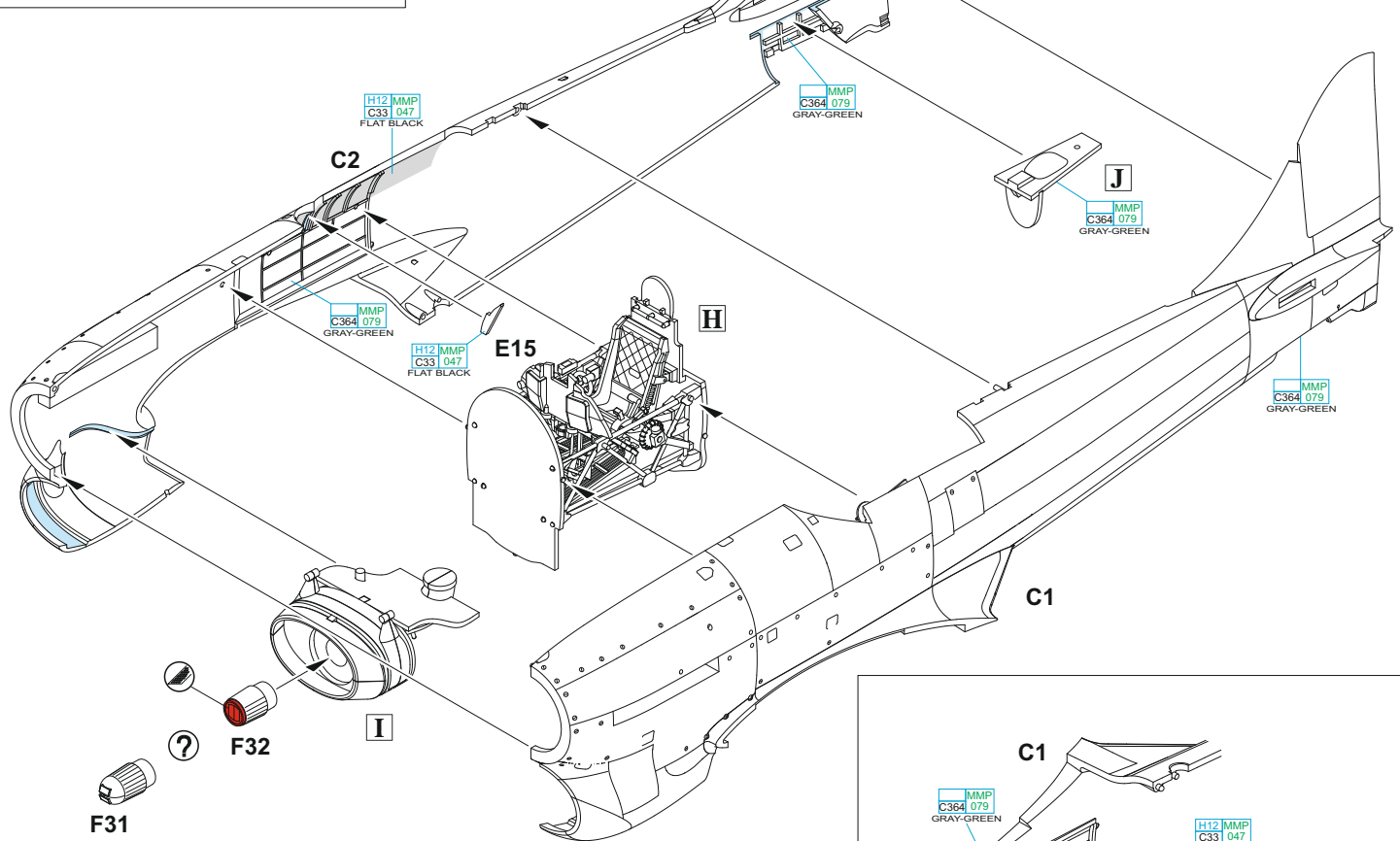
E45**E44****J****E41****E31****CROSS SECTION****E21****E43****E49****E45****E44****E77, E80****E42**

H12 MMP
C331 047
FLAT BLACK

C2

MMP
C364 079
GRAY-GREEN

J

MMP
C364 079
GRAY-GREEN

MMP
C364 079
GRAY-GREEN

H12 MMP
C331 047
FLAT BLACK

E15**H**

MMP
C364 079
GRAY-GREEN

C1**F31****F32****I**

F32 - MARKINGS F;G;H;I;J;K ONLY

F31 - MARKINGS L;M;N ONLY

**OPTIONAL:
decal 98**

H12 MMP
C331 047
FLAT BLACK

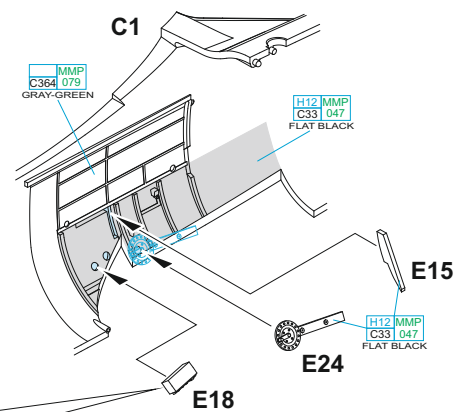
E18

MMP
C364 079
GRAY-GREEN

C1

H12 MMP
C331 047
FLAT BLACK

E15

H12 MMP
C331 047
FLAT BLACK

E24**E18**

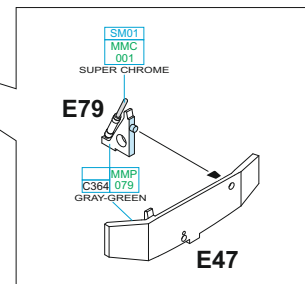
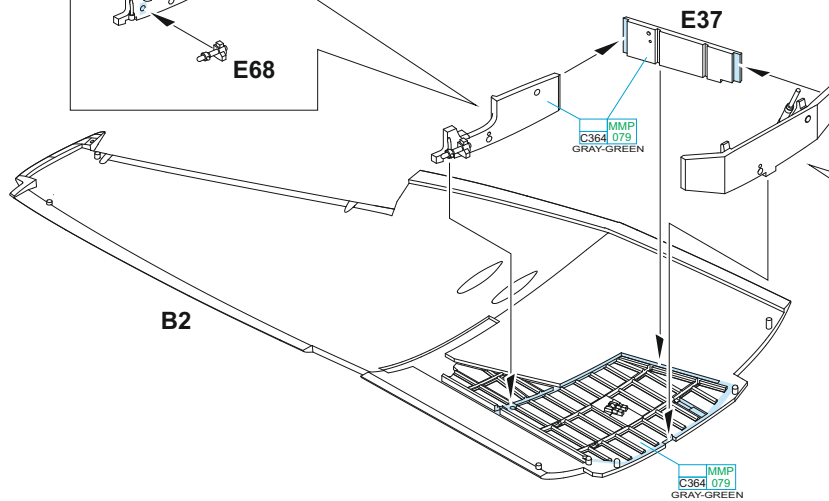
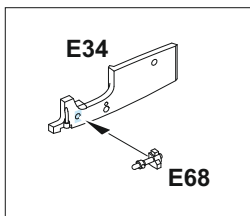
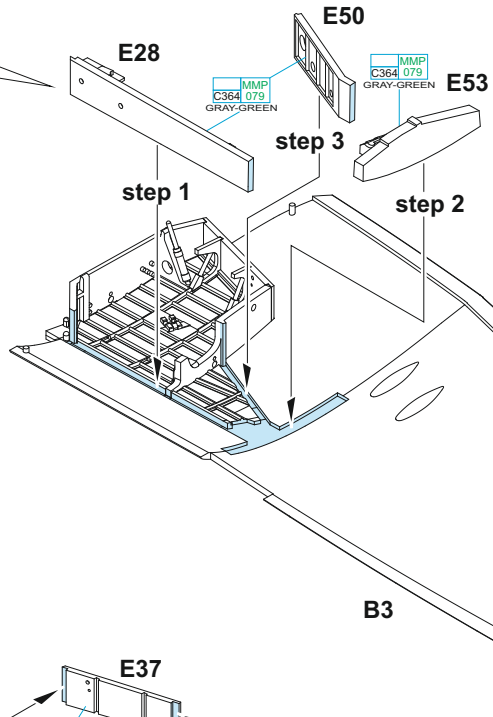
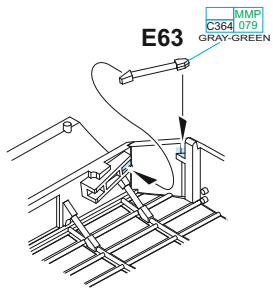
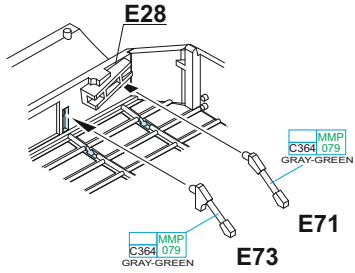
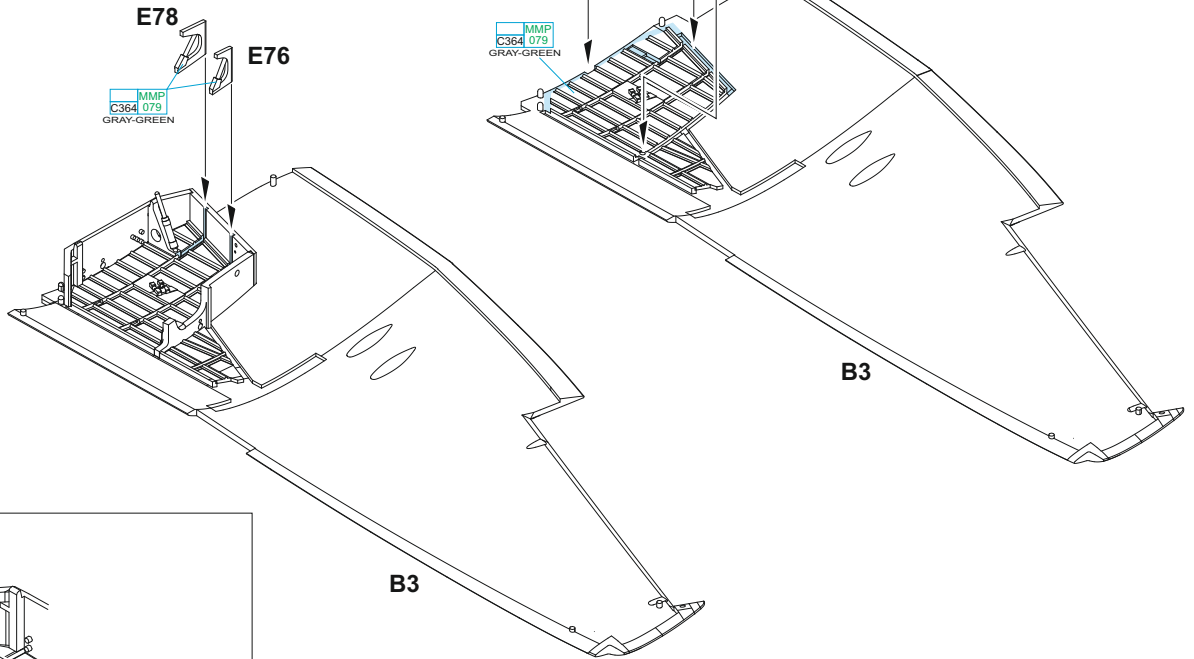
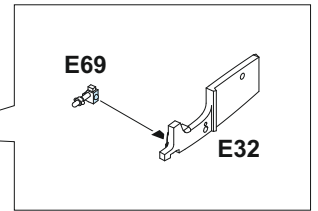
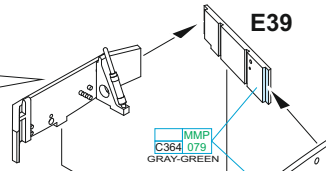
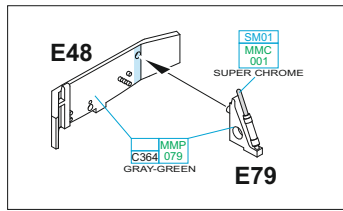

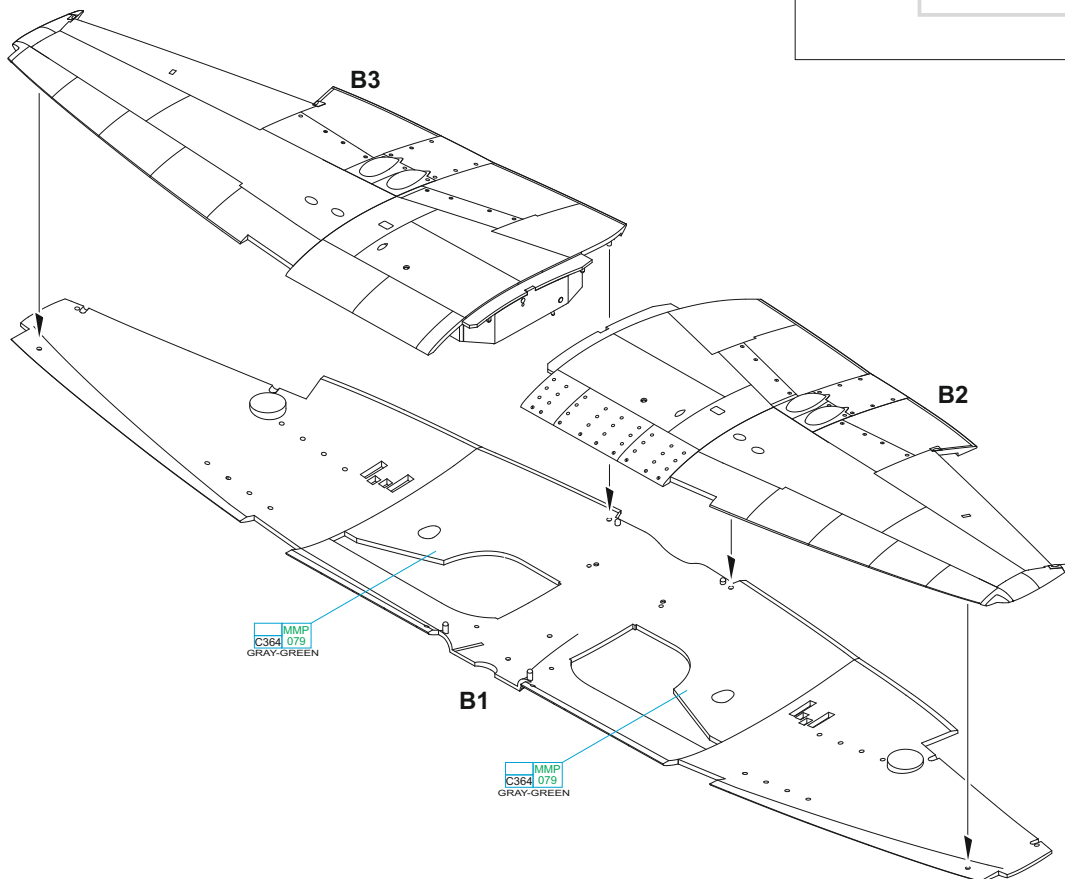
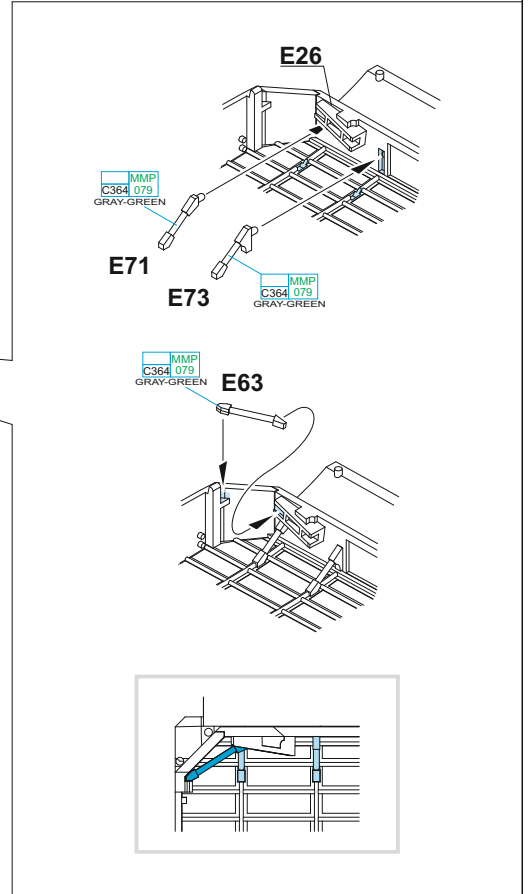
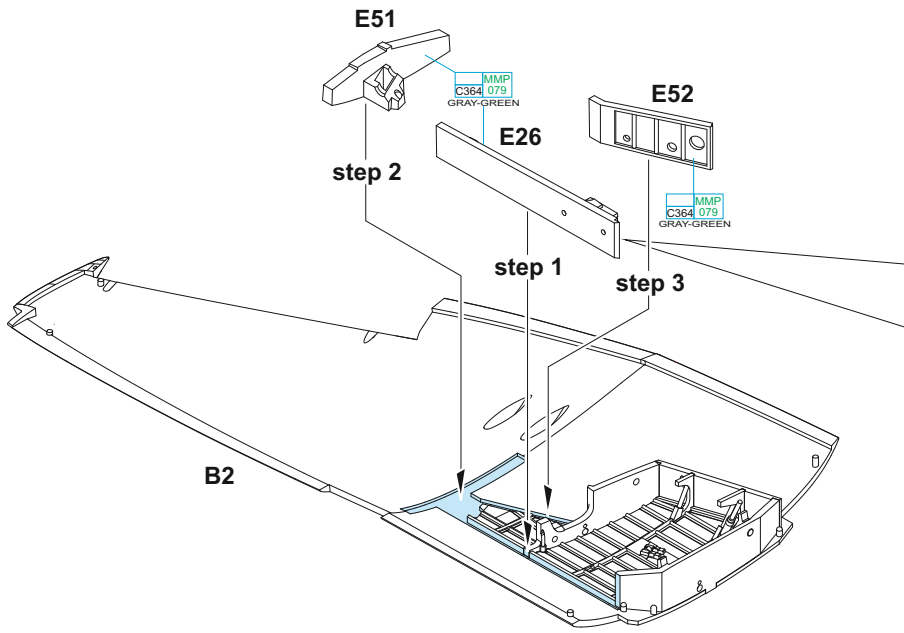
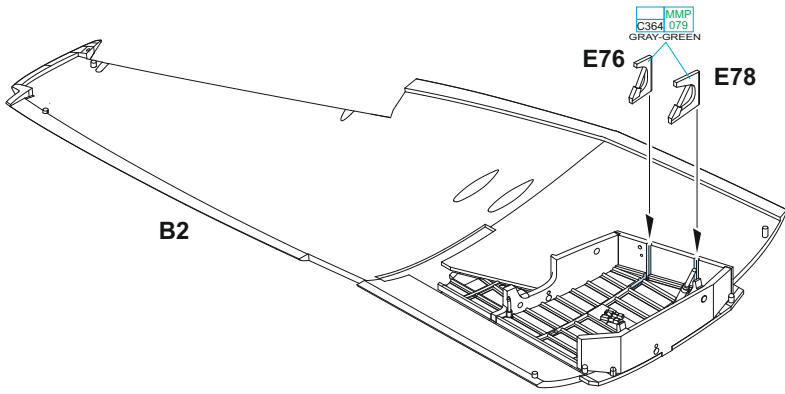

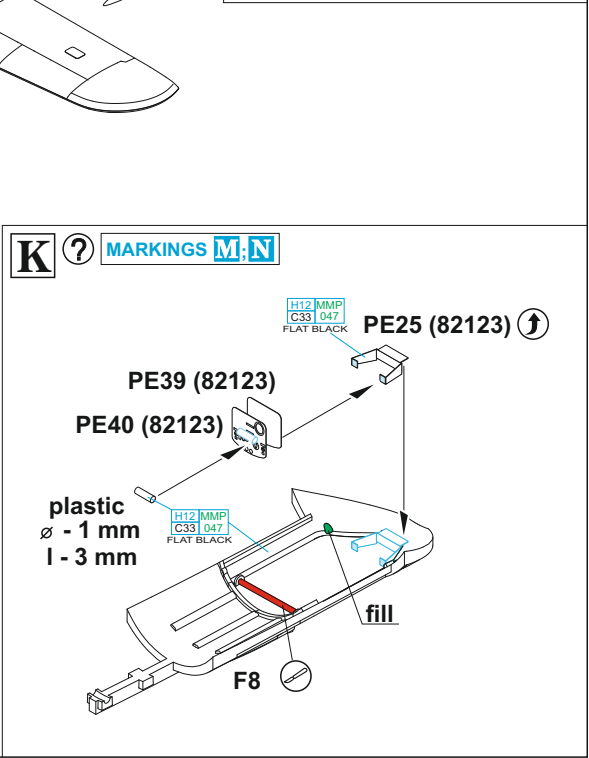
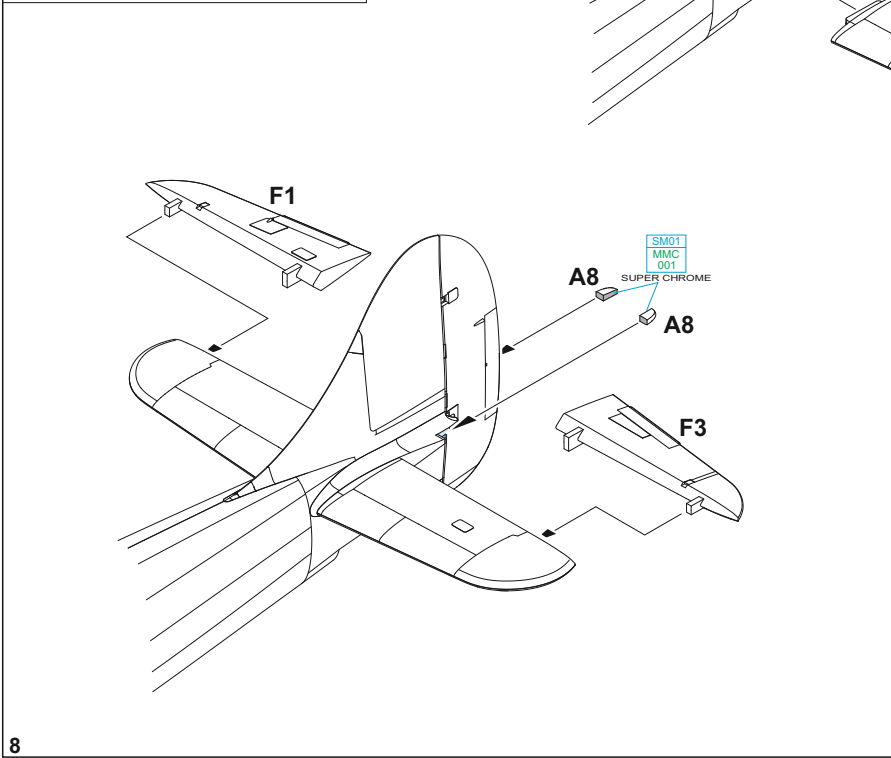
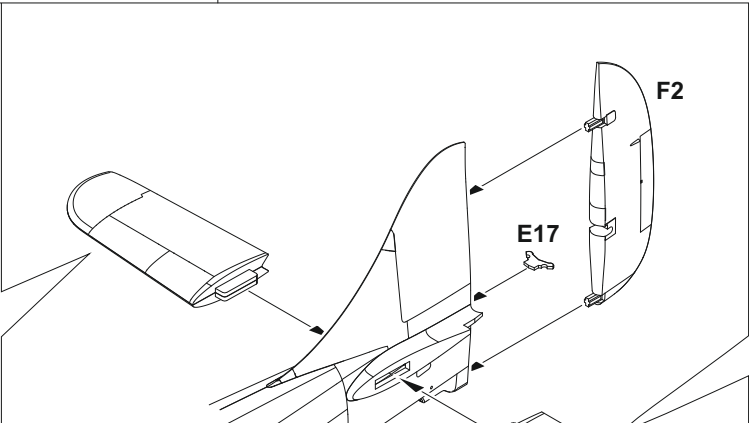
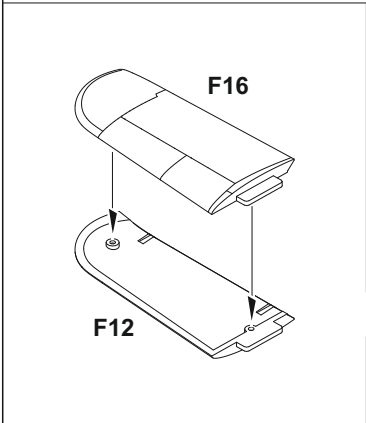
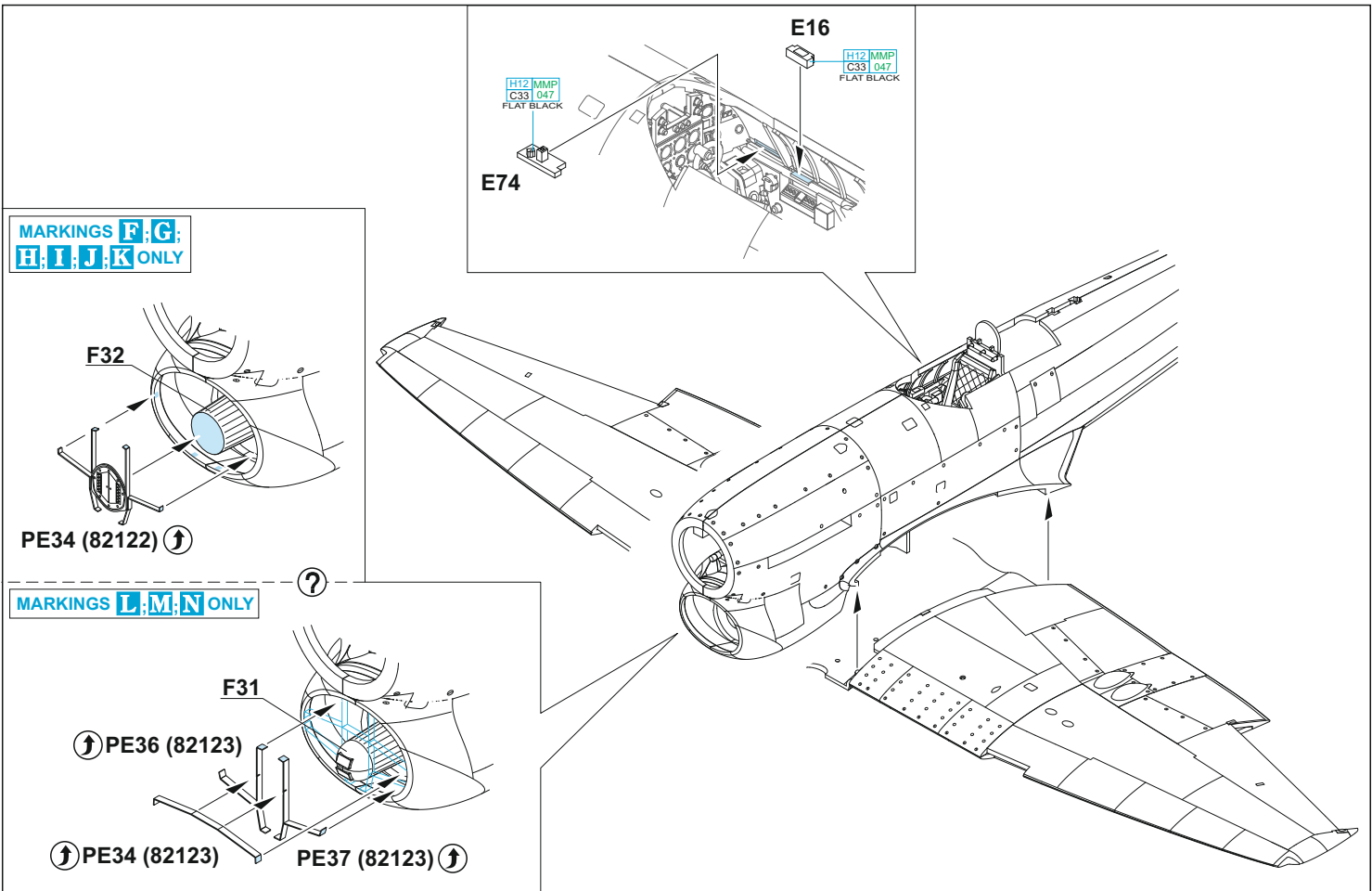

K MARKINGS **A,B,C,E**
F,G,H,J

MARKINGS **D,I,K,L**

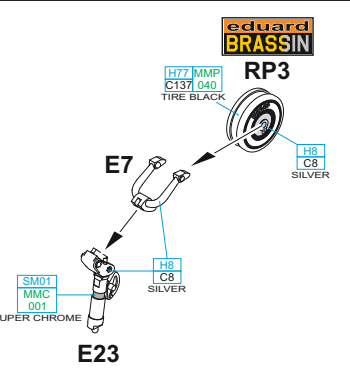
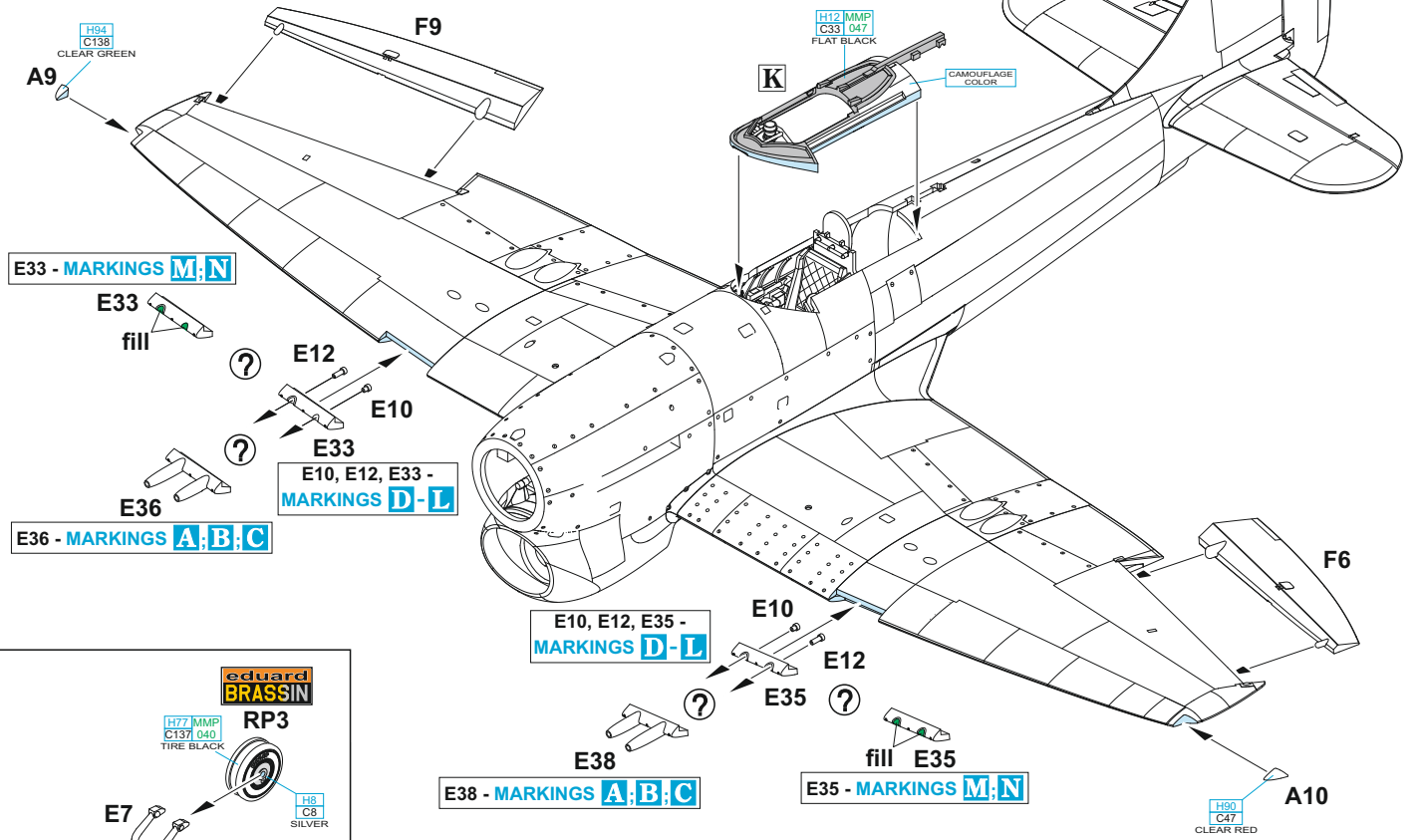
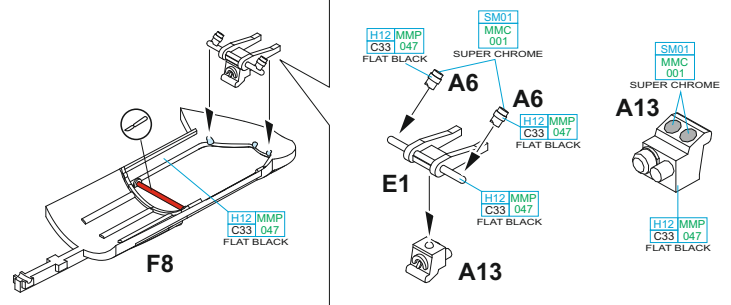
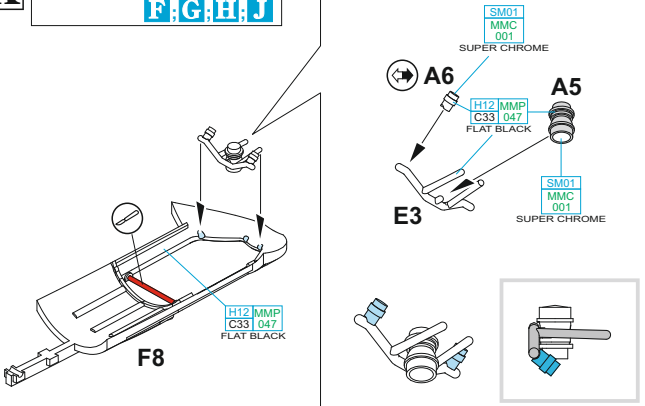

PE35, PE38 - MARKINGS **M,N ONLY**

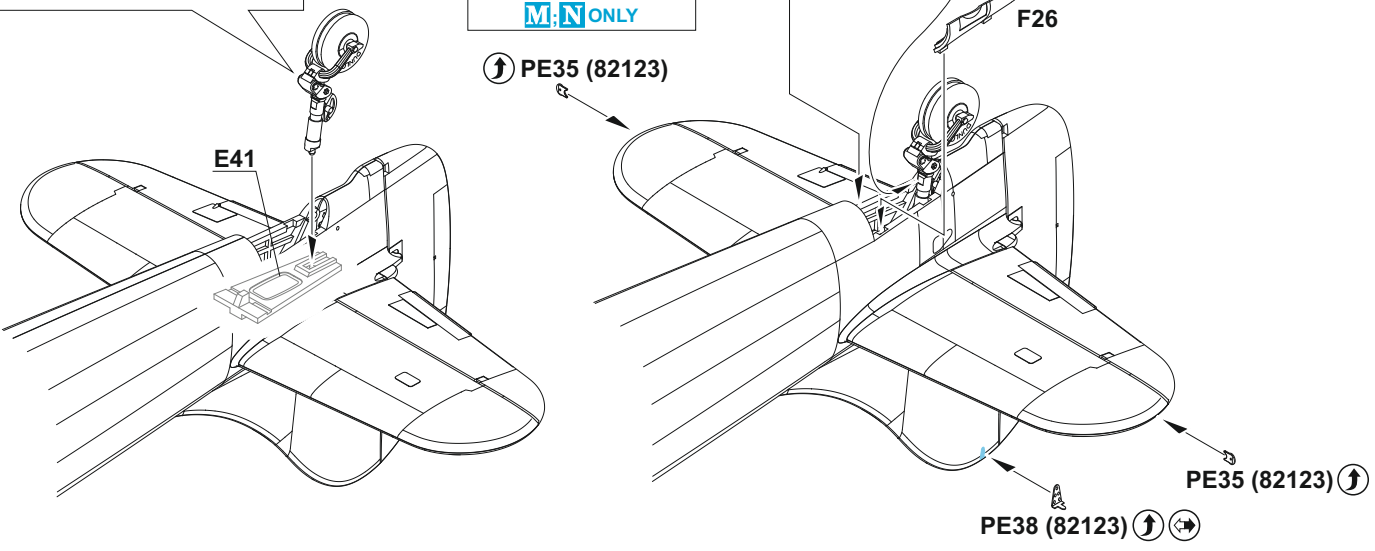

MARKINGS A, B, C

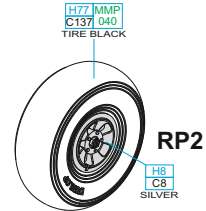
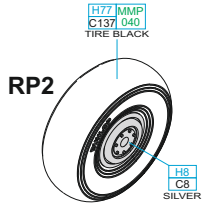

MARKINGS D-N

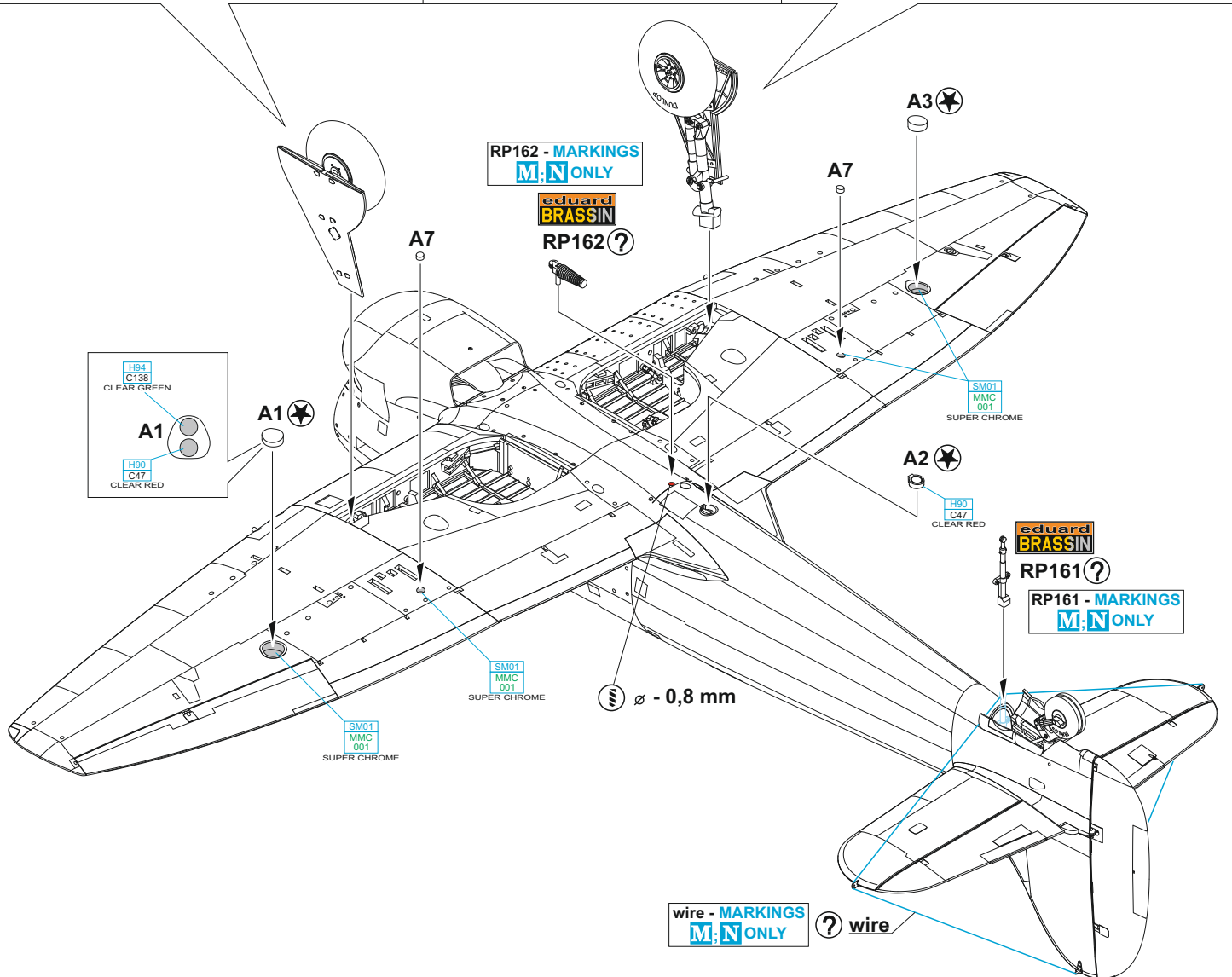
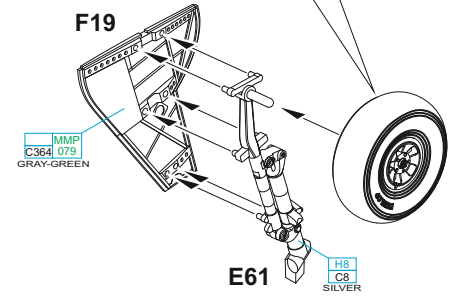
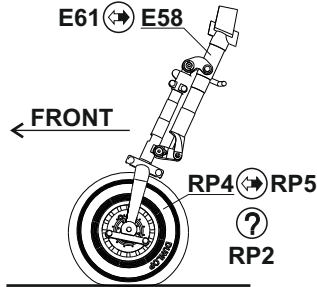
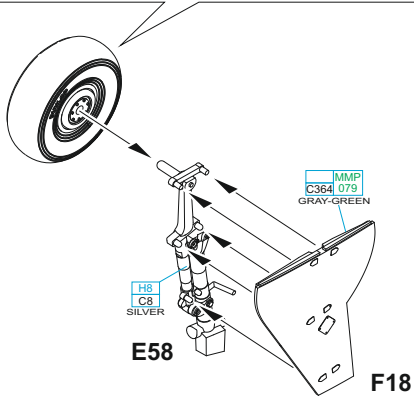
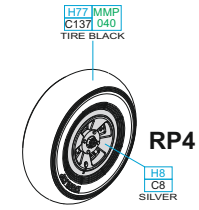
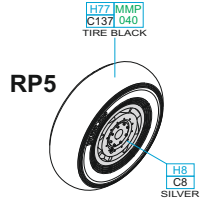

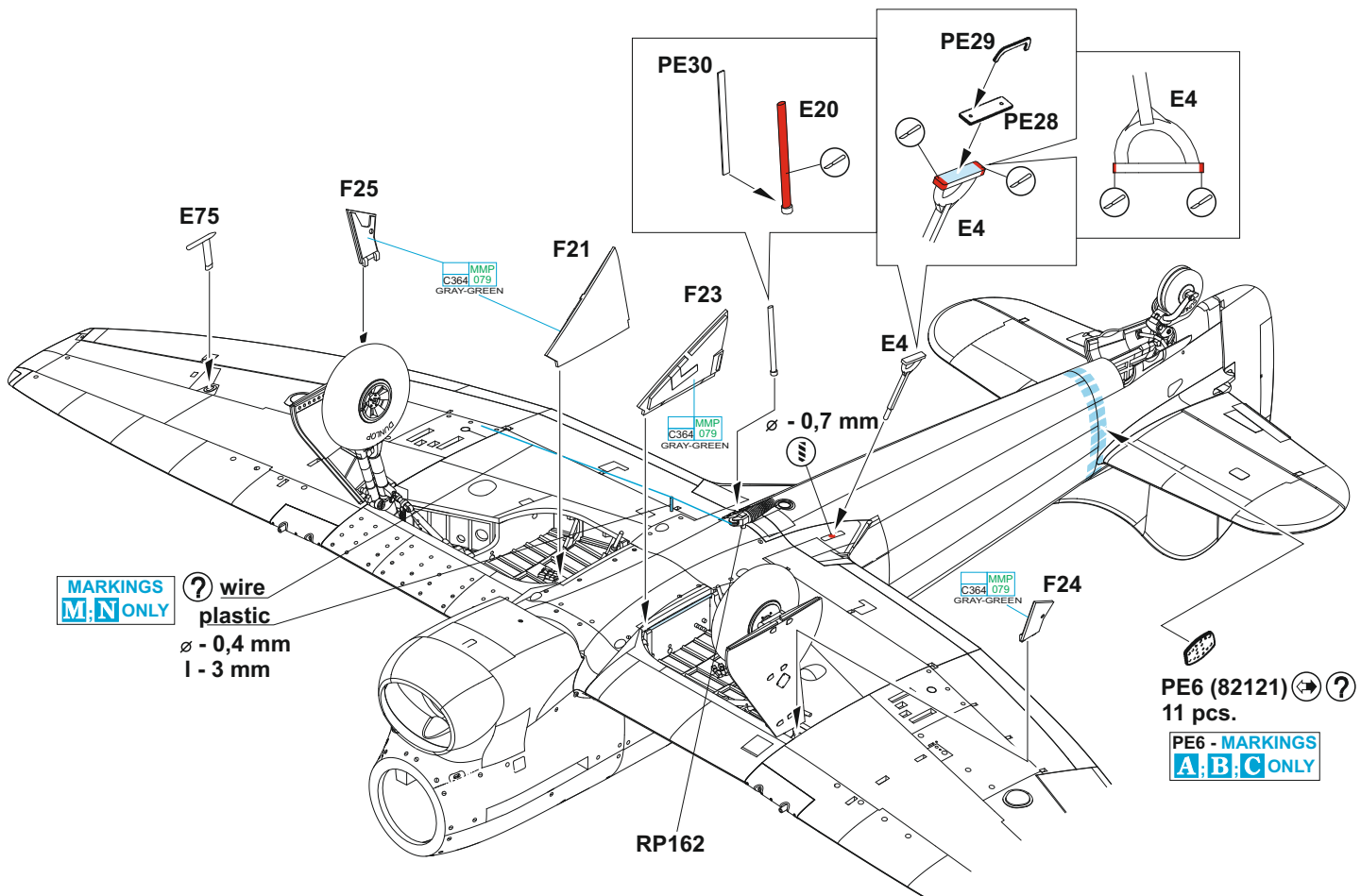
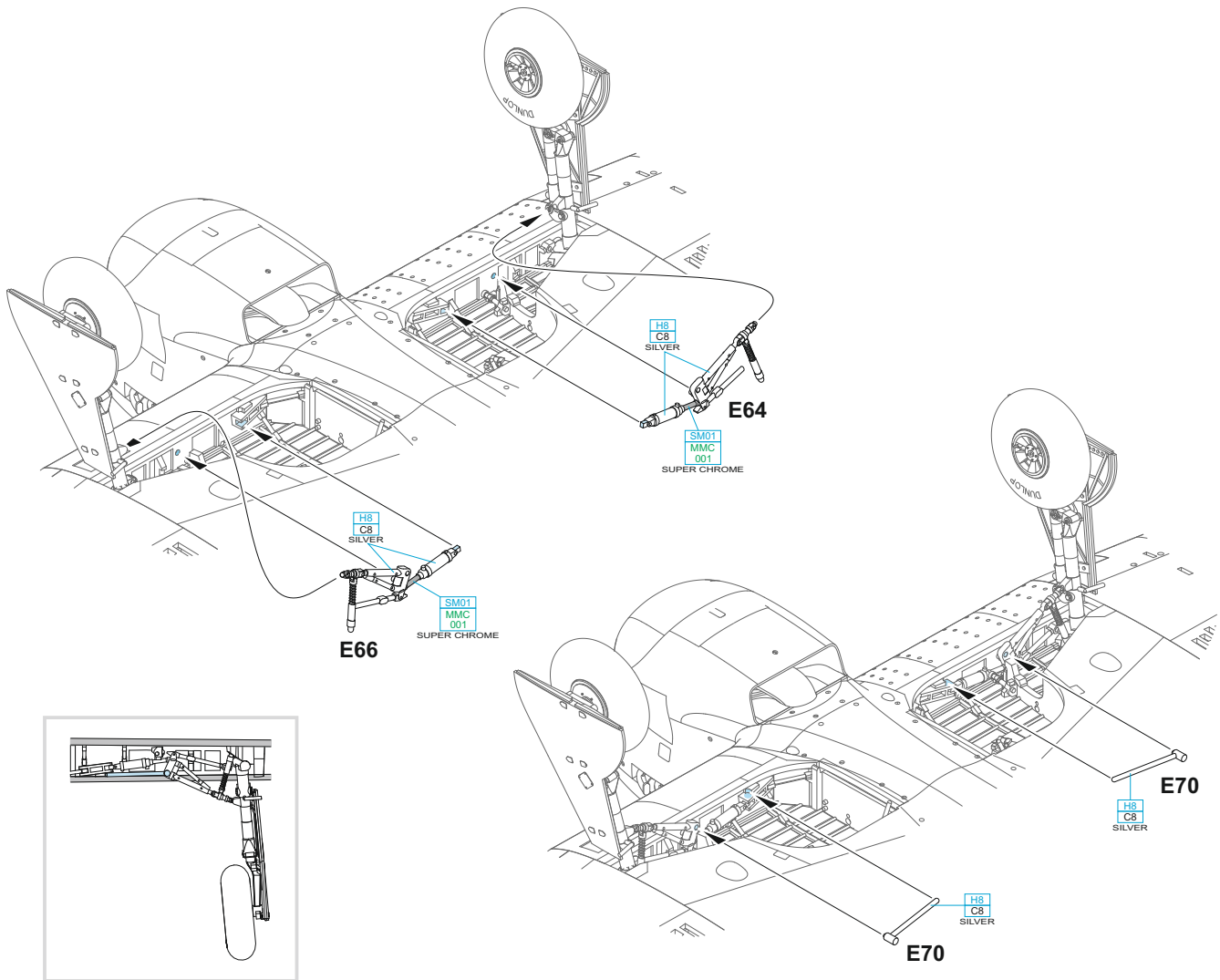

L

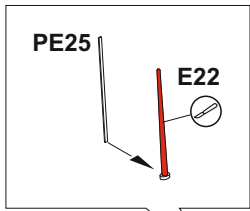
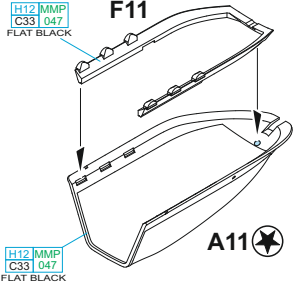

CLOSED CANOPY

L

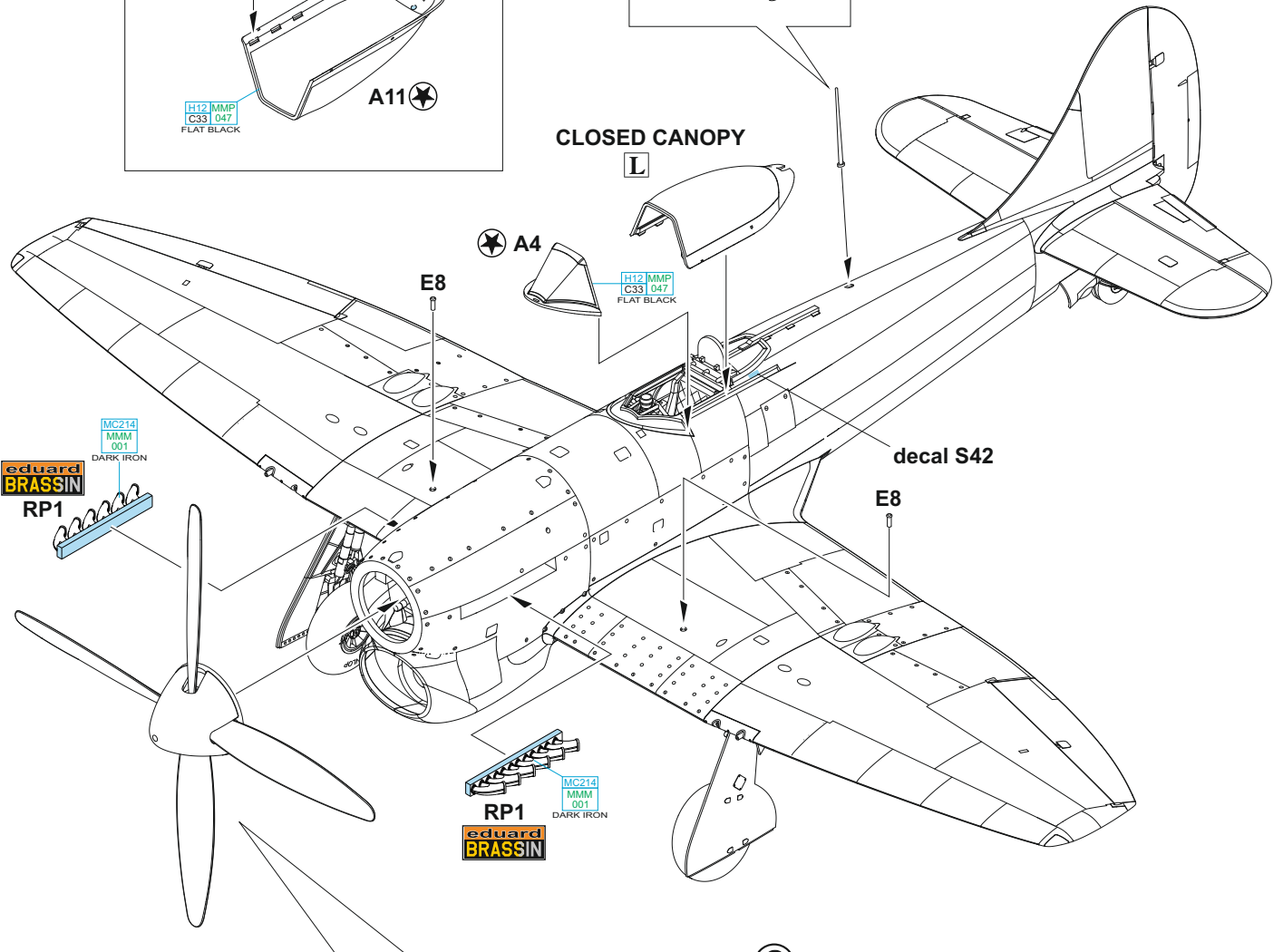

?

F28, F29, F30 - MARKINGS **A, B, C, D, E, F, H, K, L, M, N**
 F5, F7, F22 - MARKINGS **G, I, J**

OPEN CANOPY

L

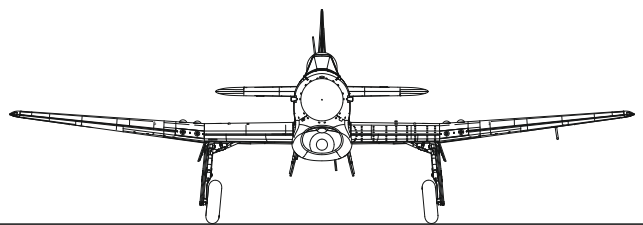
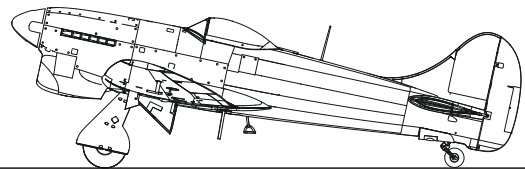
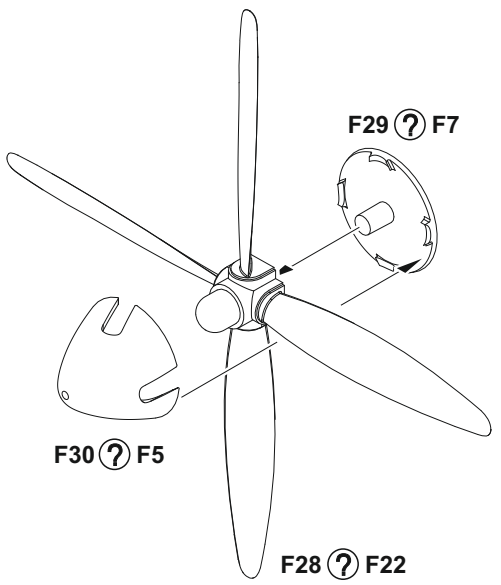
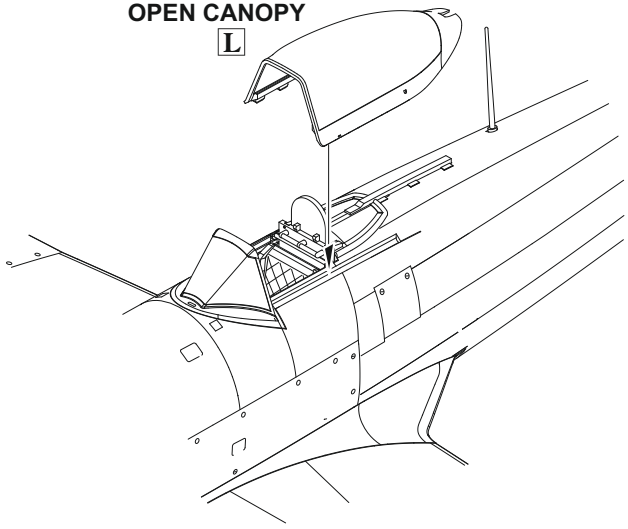

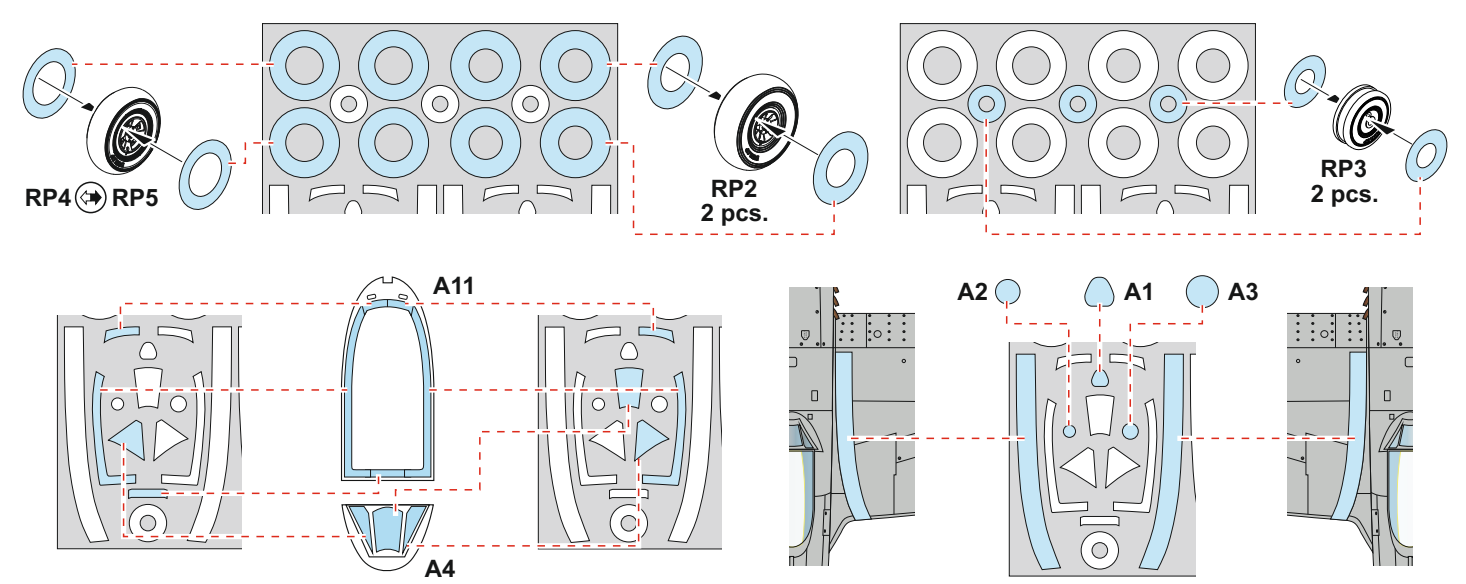
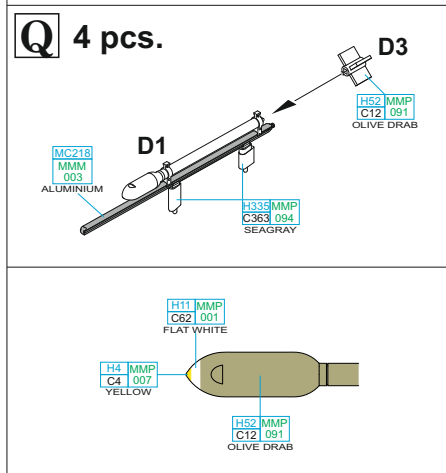
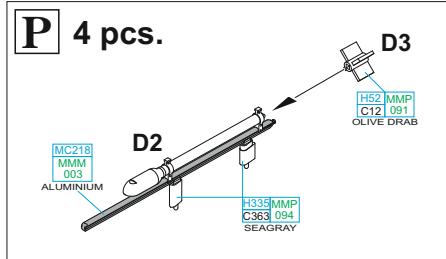
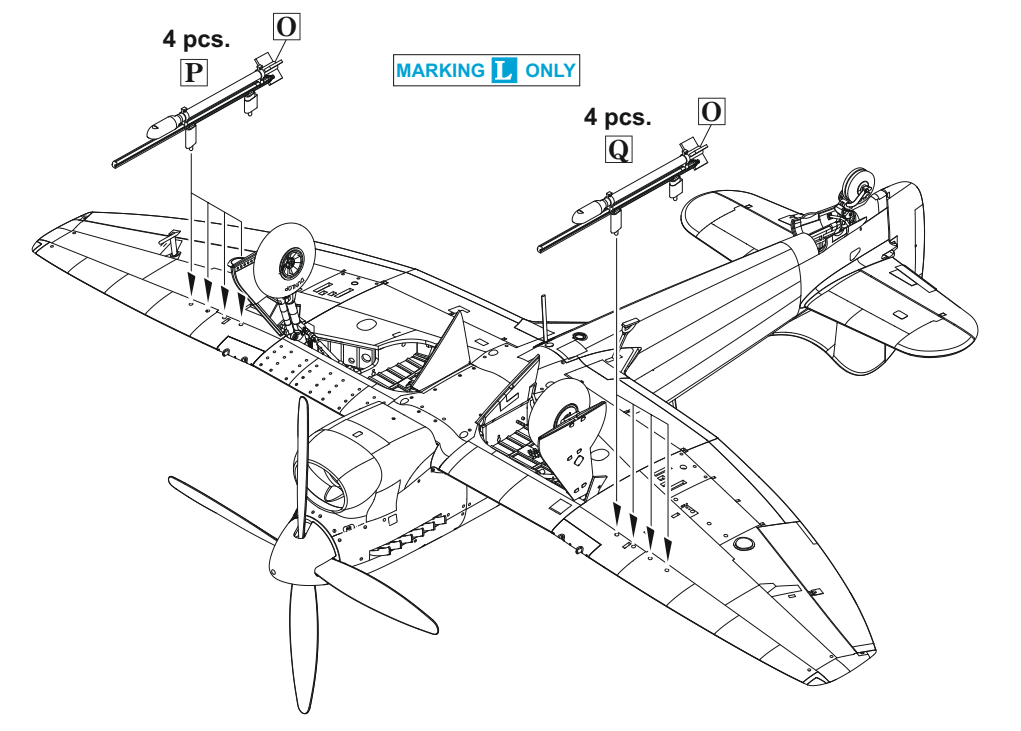
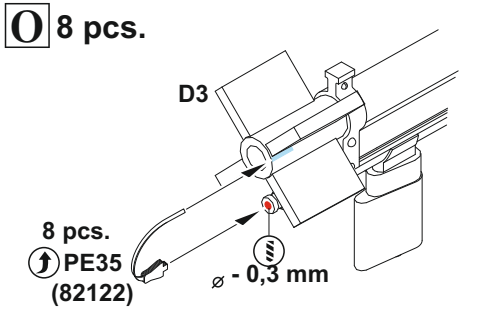
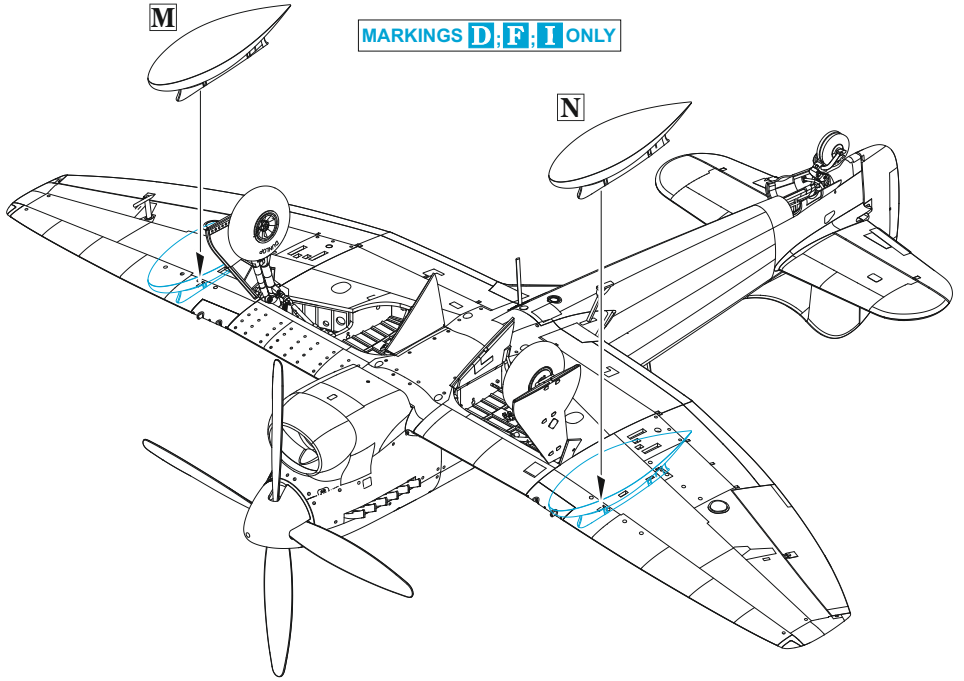
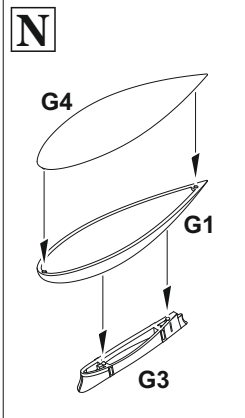
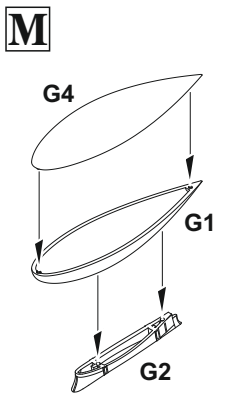

A Tempest Mk.V Series 1, JN751, flown by W/Cdr Roland P. Beamont, CO of No. 150 Wing, RAF Station Bradwell Bay, Great Britain, April 1944

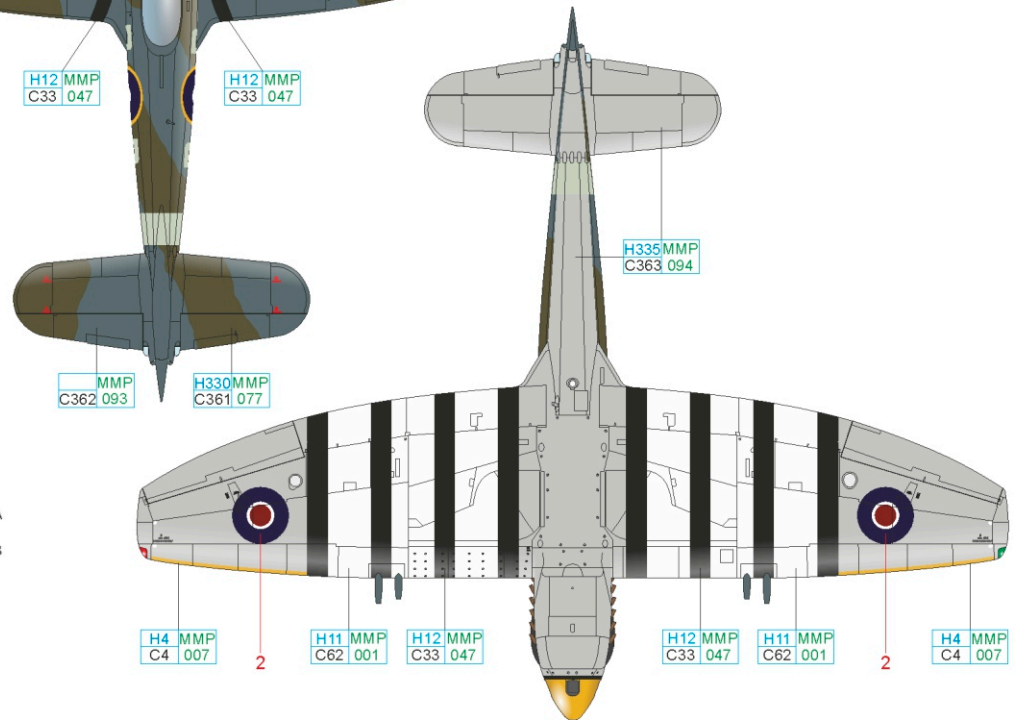
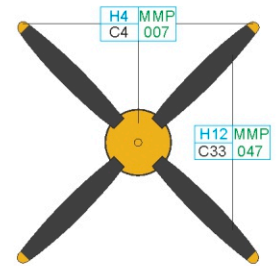
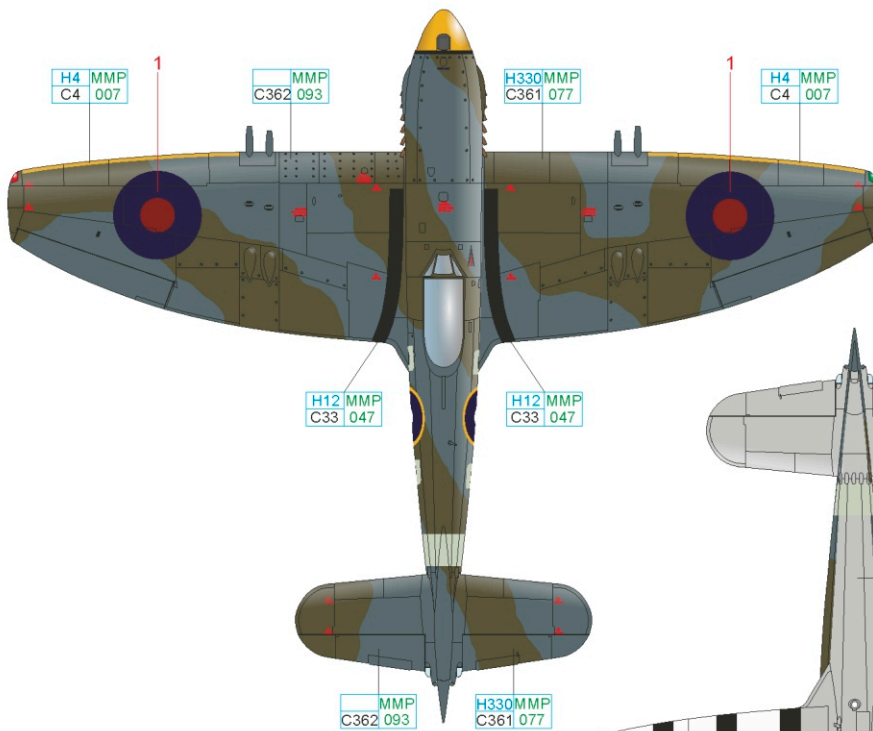
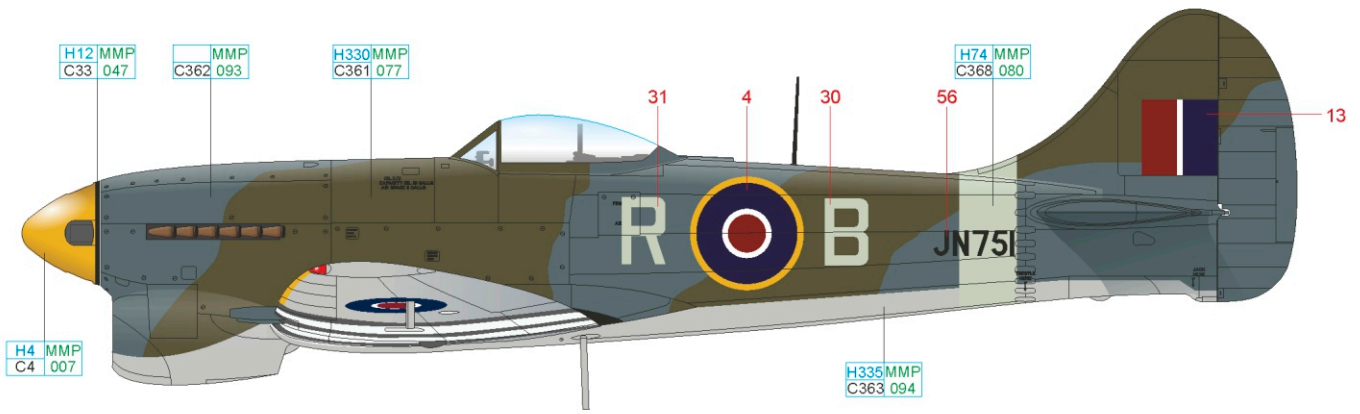

ČESKOU VERZI TEXTU NALEZNETE NA
www.eduard.com
 POD KATALOGOVÝM ČÍSLEM R0018

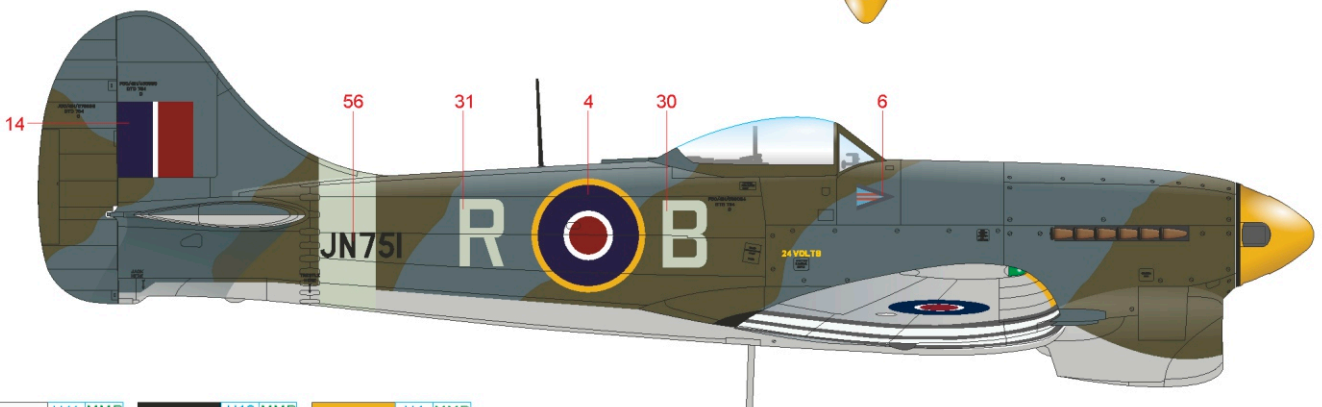

WHITE	H11 MMP C62 001	BLACK	H12 MMP C33 047	YELLOW	H4 MMP C4 007
MEDIUM SEA GRAY	H335MMP C363 094	DARK GREEN	H330MMP C361 077	OCEAN GRAY	MMP C362 093
		SKY	H74 MMP C368 080		

B Tempest Mk.V Series 1, JN754, flown by F/Lt H. N. Sweetman, No. 486 Squadron, RAF Station Newchurch, June 1944

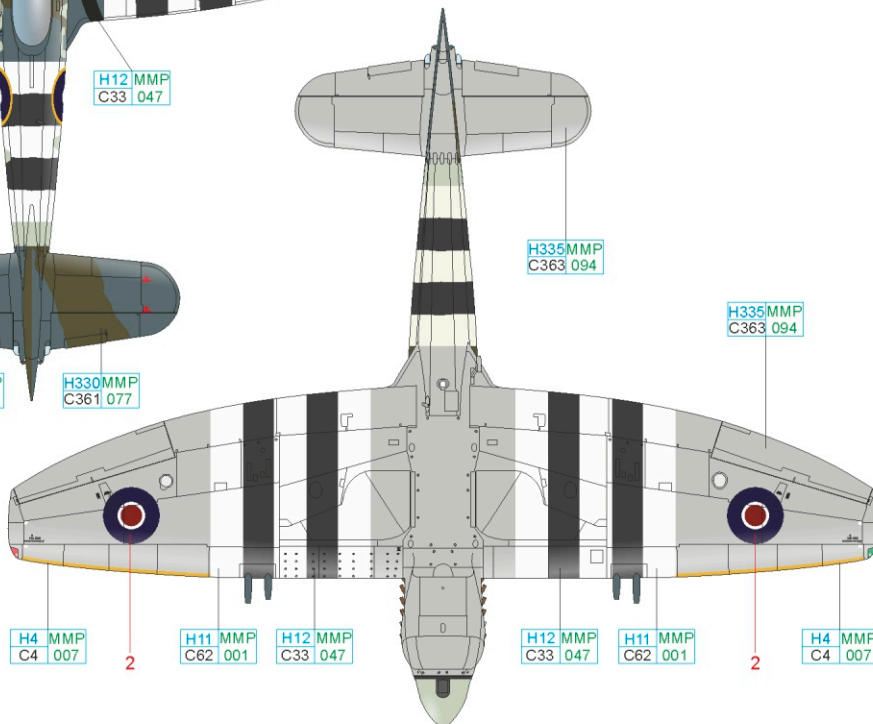
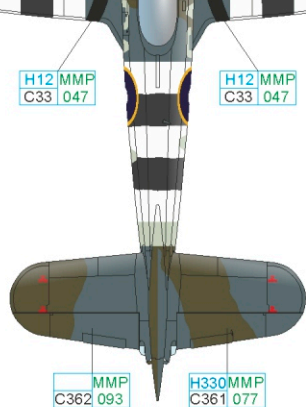
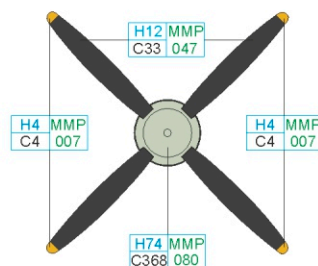
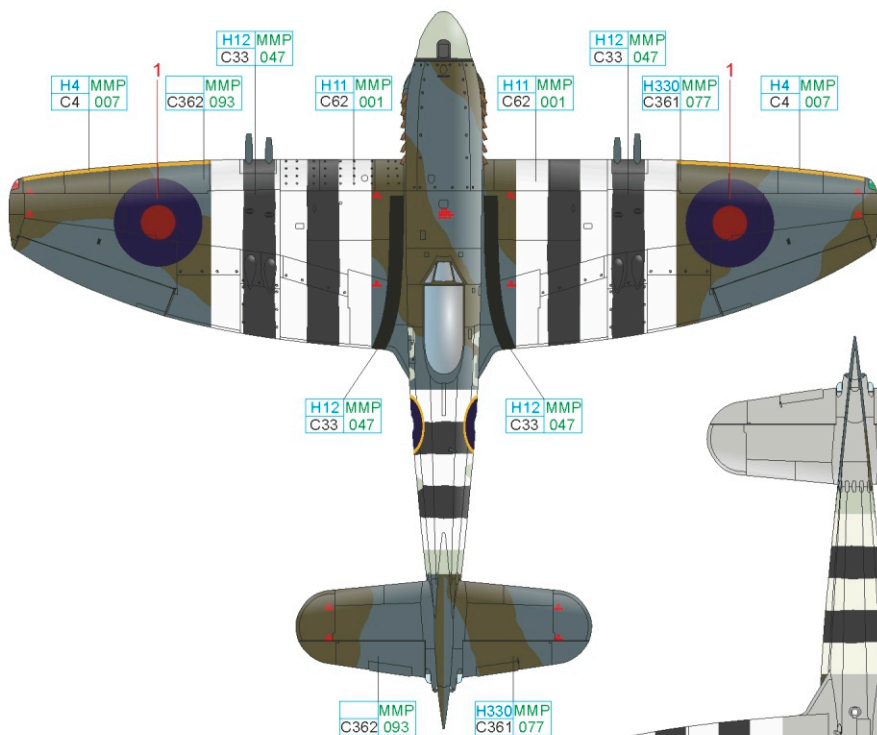
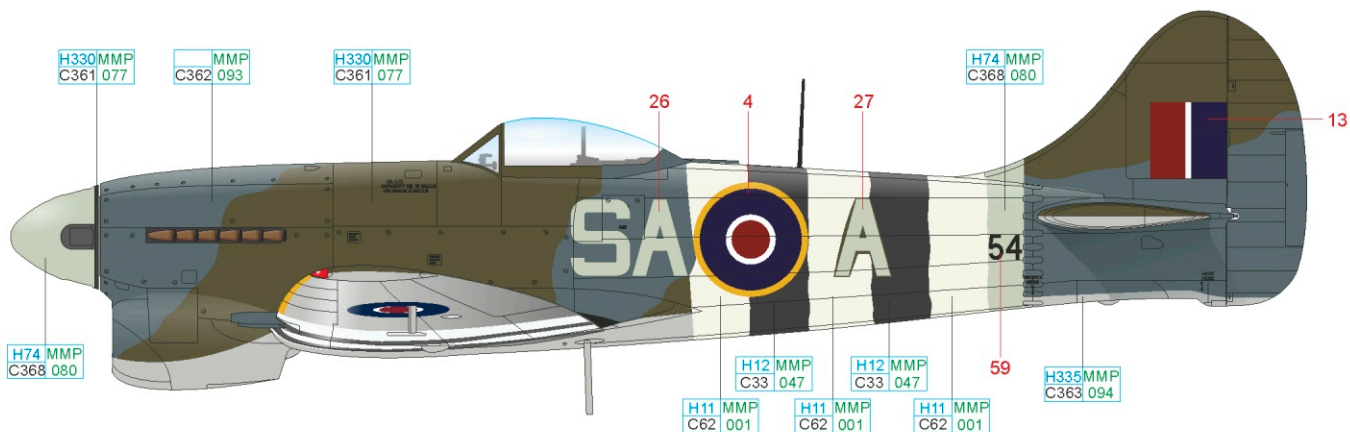

ČESKOU VERZI TEXTU NALEZNETE NA
www.eduard.com
POD KATALOGOVÝM ČÍSLEM R0018

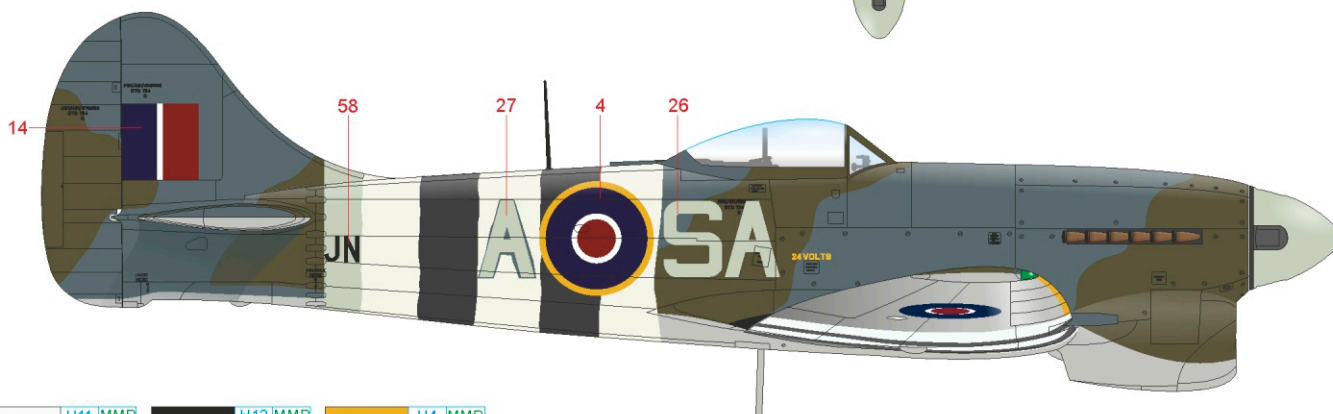

WHITE	H11 MMP C62 001	BLACK	H12 MMP C33 047	YELLOW	H4 MMP C4 007
MEDIUM SEA GRAY	H335MMP C363 094	DARK GREEN	H330MMP C361 077	OCEAN GRAY	MMP C362 093
				SKY	H74 MMP C368 080

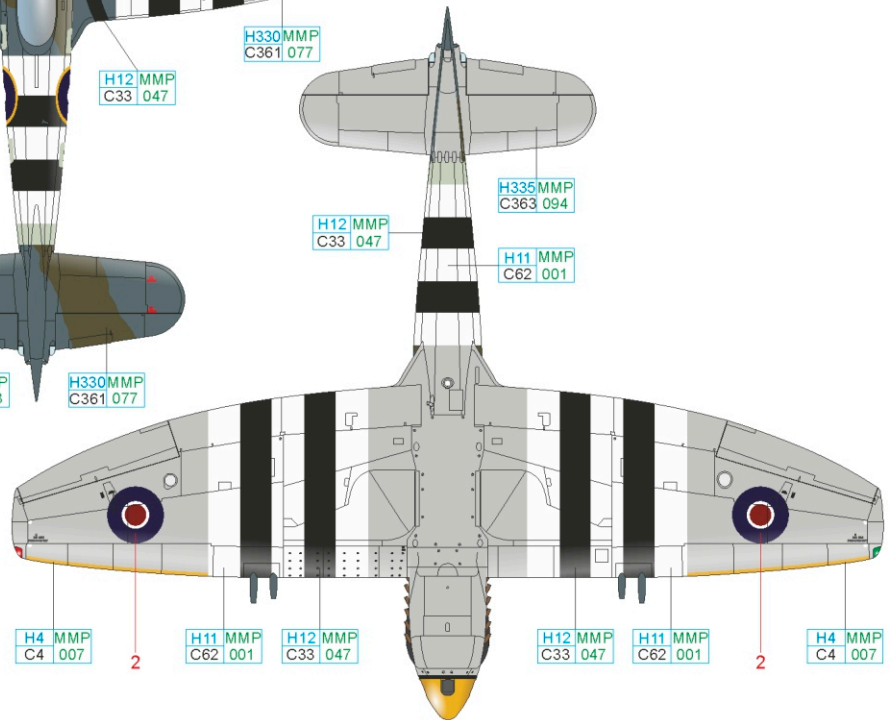
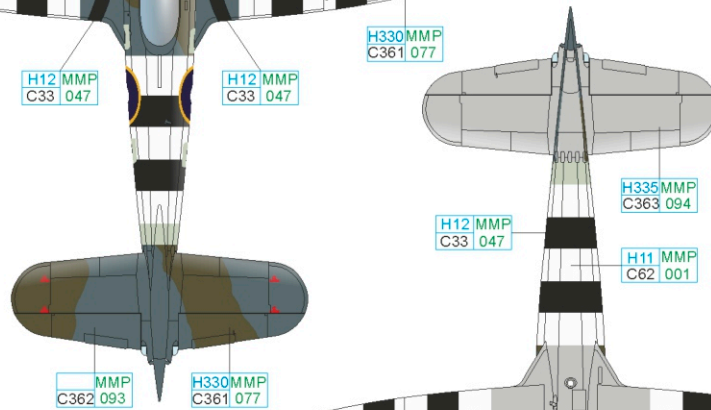
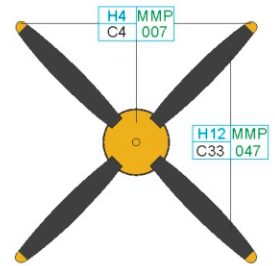
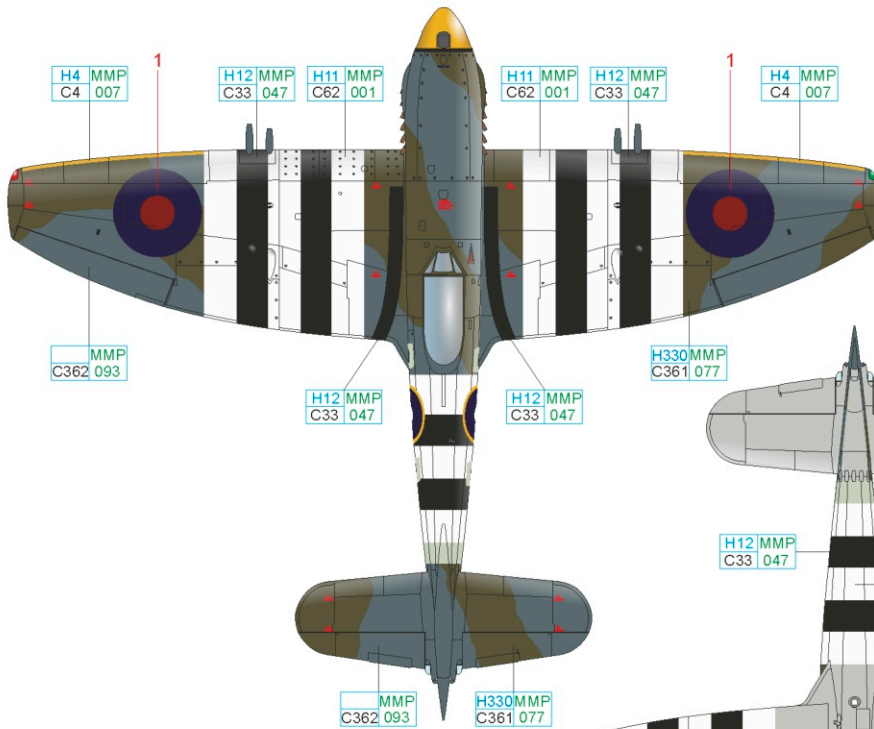
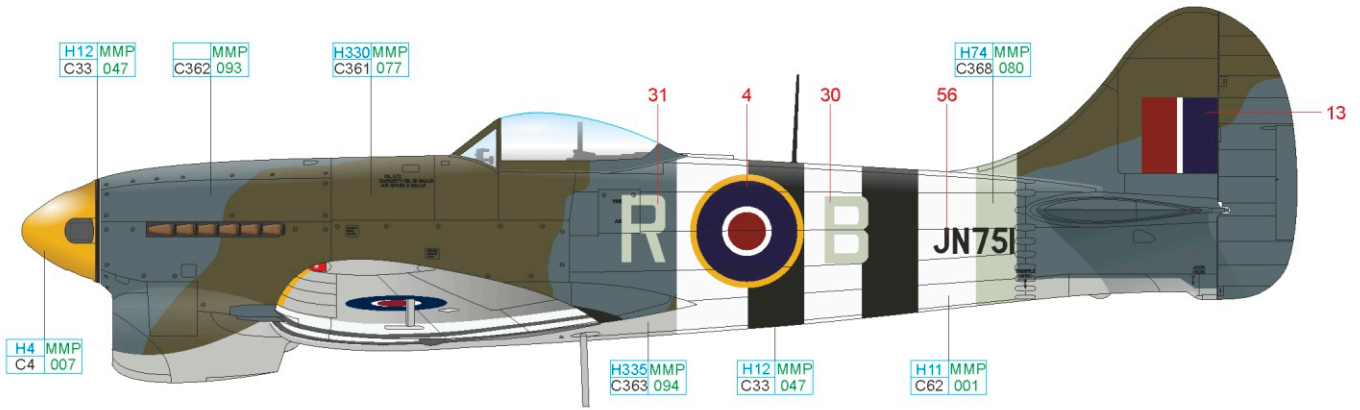

ČESKOU VERZI TEXTU NALEZNETE NA
www.eduard.com
 POD KATALOGOVÝM ČÍSLEM R0018

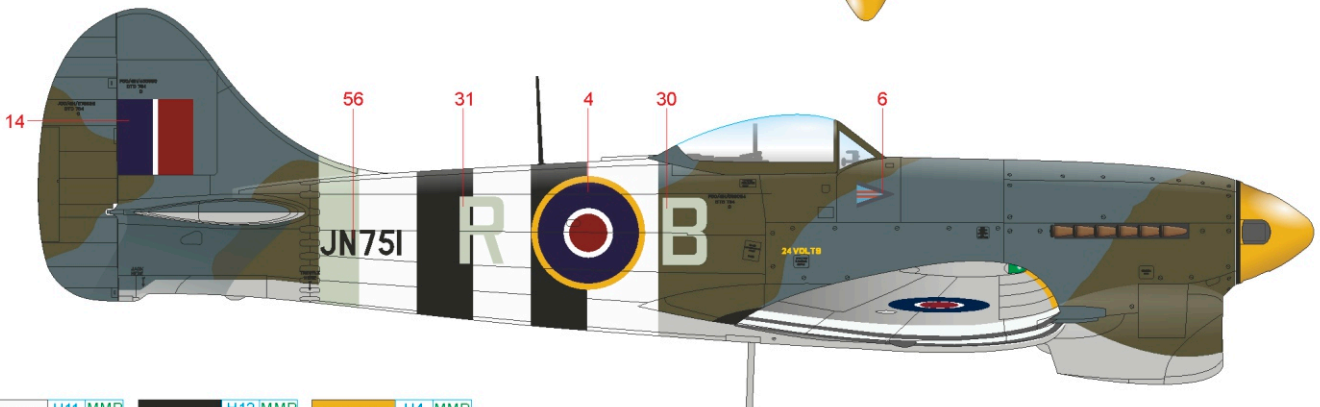

WHITE	H11 MMP C62 001	BLACK	H12 MMP C33 047	YELLOW	H4 MMP C4 007
MEDIUM SEA GRAY	H335MMP C363 094	DARK GREEN	H330MMP C361 077	OCEAN GRAY	MMP C362 093
		SKY	H74 MMP C368 080		

D Tempest Mk.V Series 2, EJ750, flown by W/Cdr John B. Wray, CO of No. 122 Wing, B.80 Volkel, the Netherlands, December 1944

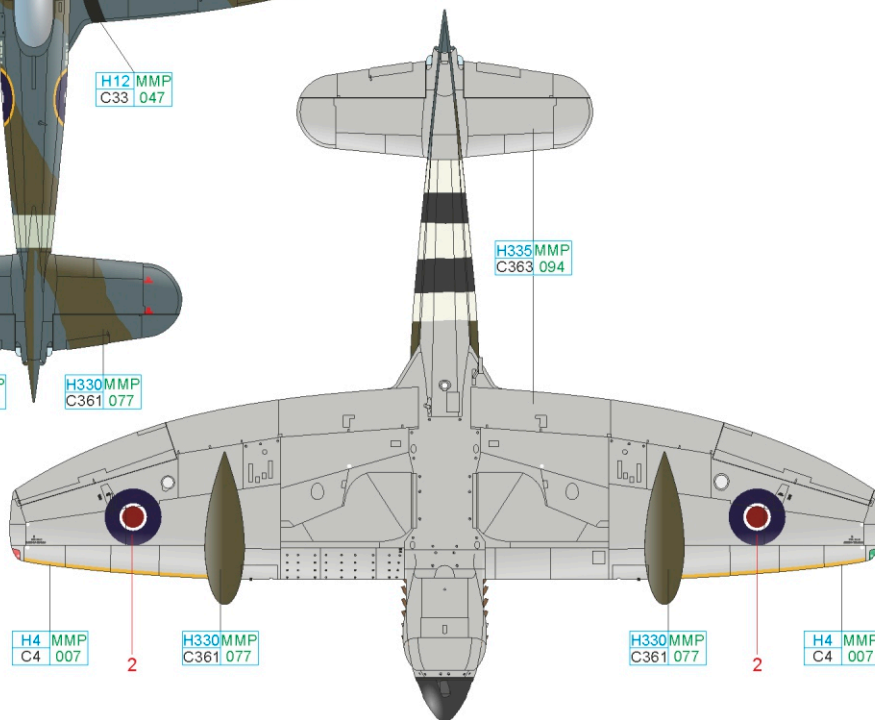
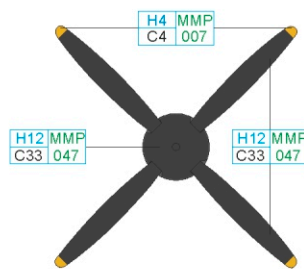
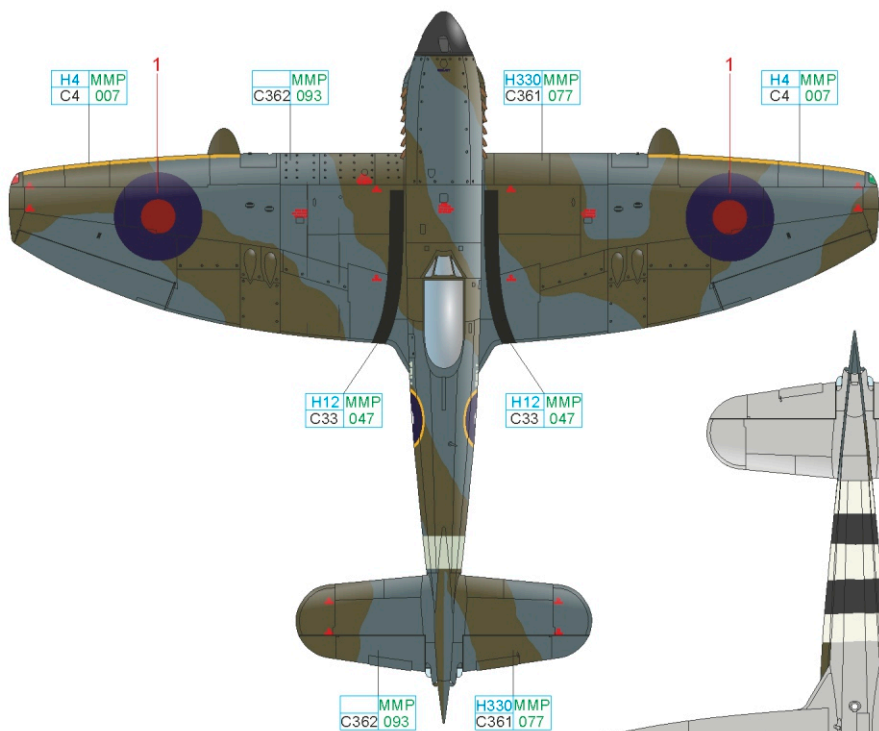
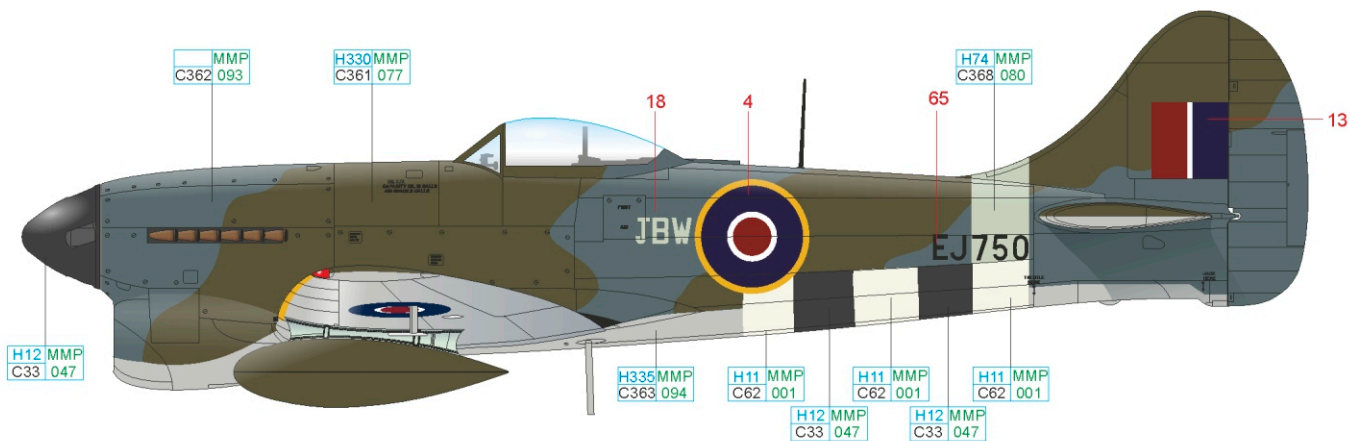

ČESKOU VERZI TEXTU NALEZNETE NA
www.eduard.com
POD KATALOGOVÝM ČÍSLEM R0018

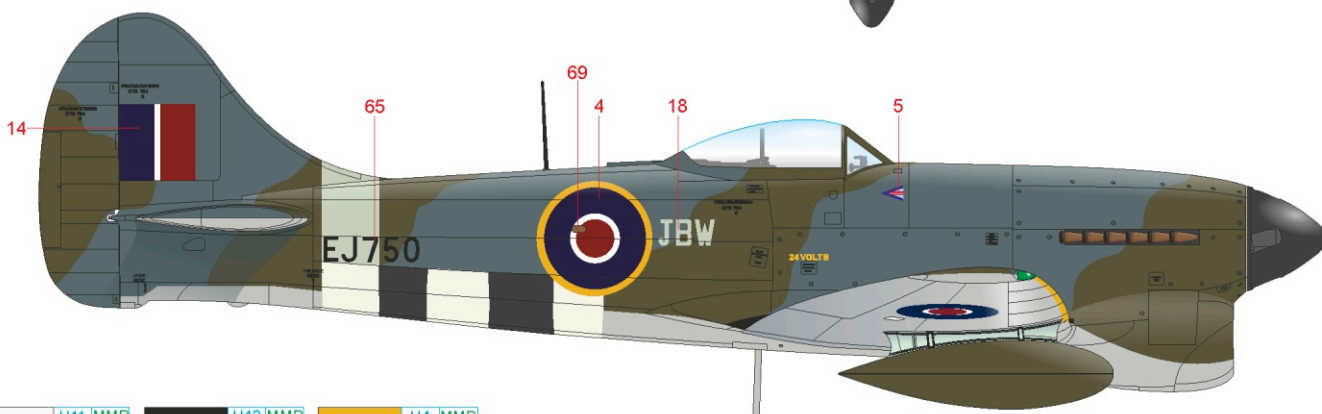

WHITE	H11 MMP C62 001	BLACK	H12 MMP C33 047	YELLOW	H4 MMP C4 007
MEDIUM SEA GRAY	H335MMP C363 094	DARK GREEN	H330MMP C361 077	OCEAN GRAY	MMP C362 093
		SKY	H74 MMP C368 080		

E Tempest Mk.V Series 2, EJ558, flown by F/O B. F. Miller (USAAF), No. 501 Squadron, RAF Station Bradwell Bay, Great Britain, October 1944

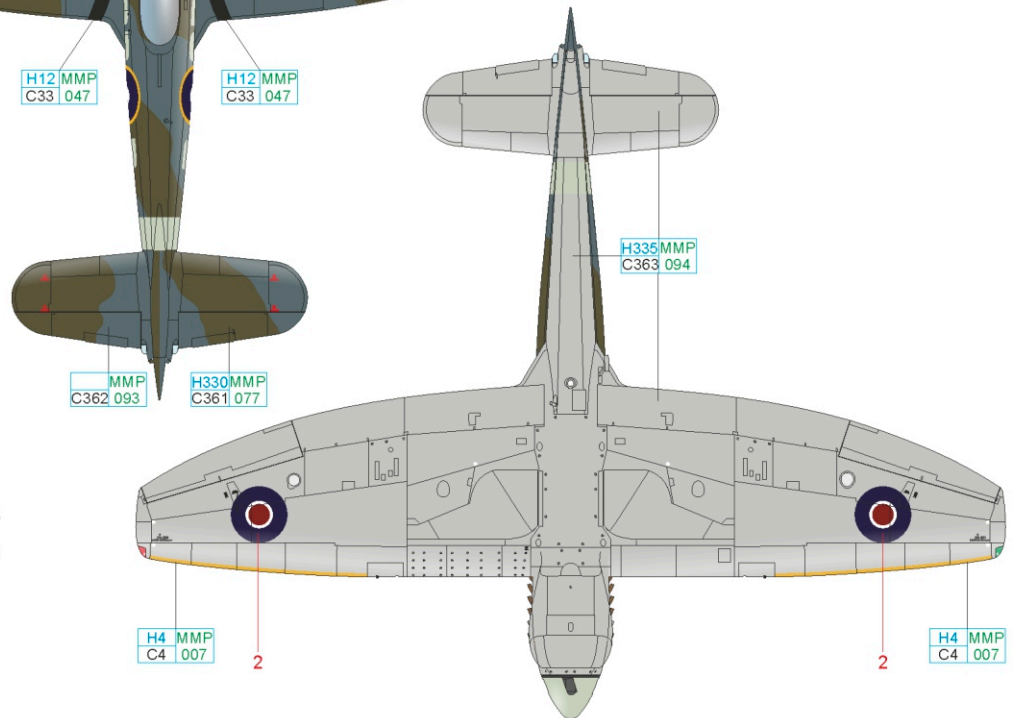
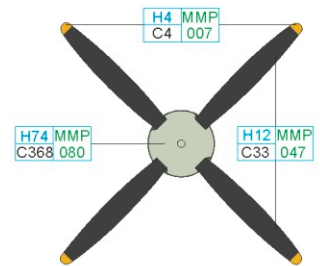
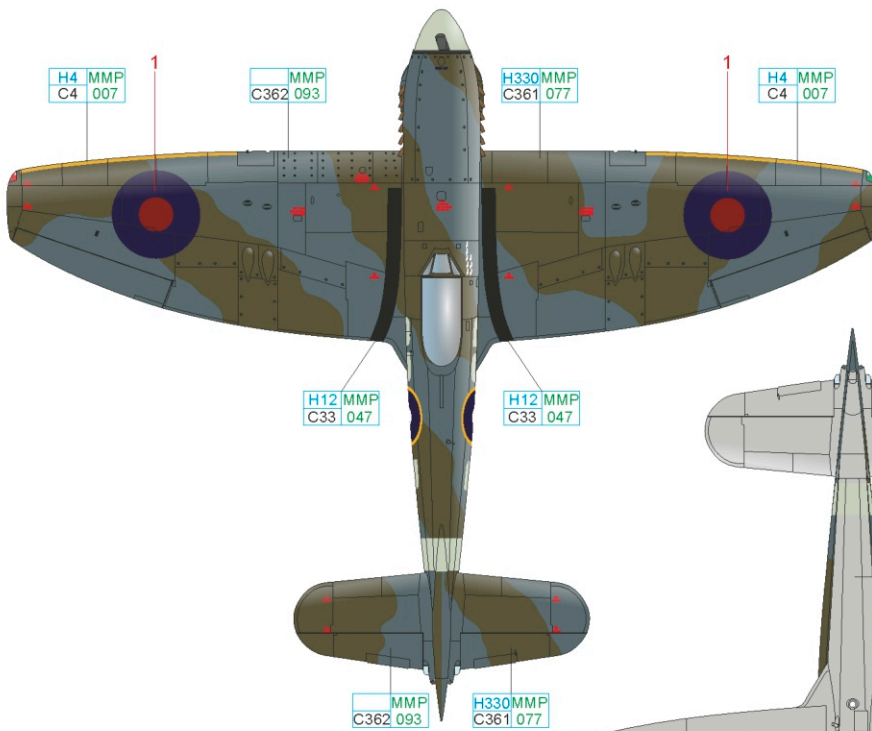
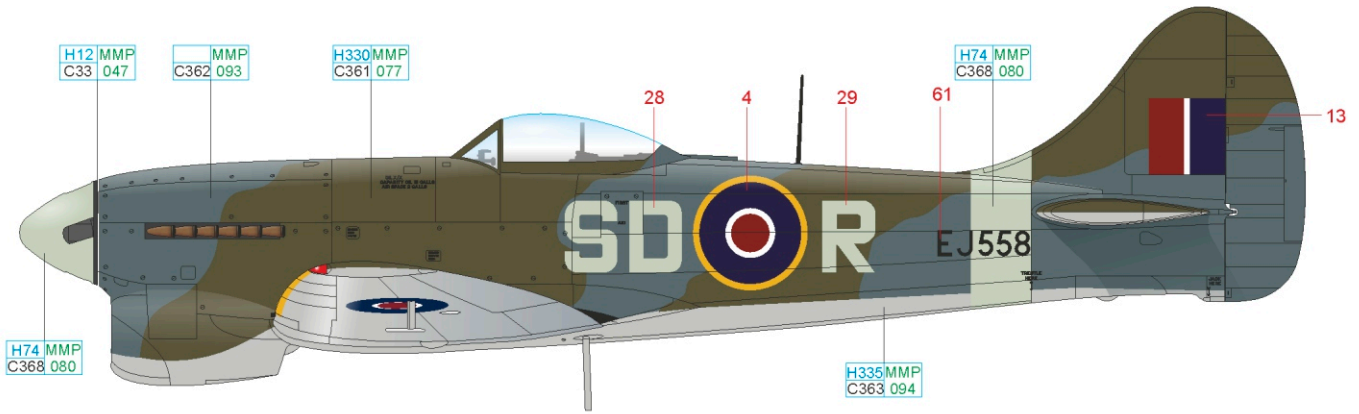

ČESKOU VERZI TEXTU NALEZNETE NA
www.eduard.com
POD KATALOGOVÝM ČÍSLEM R0018

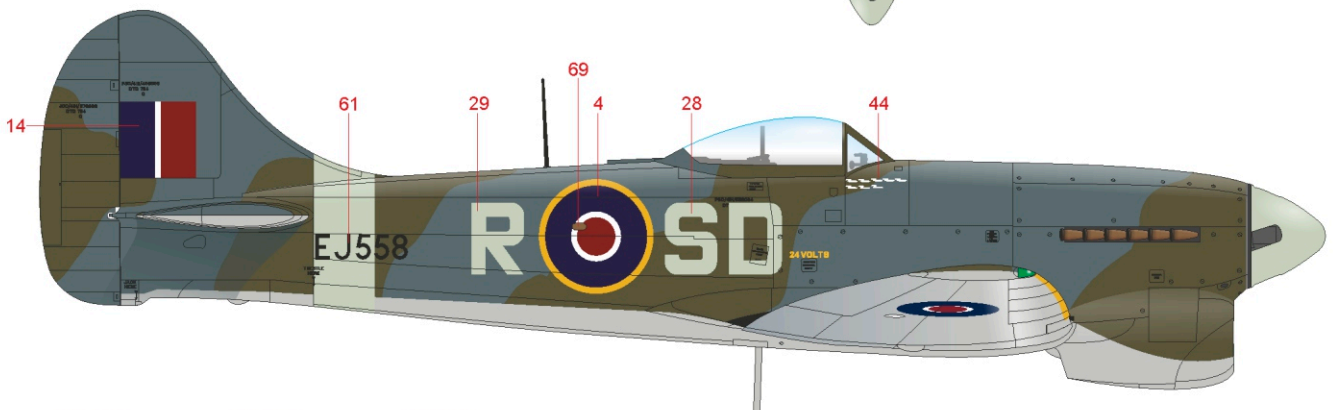

BLACK	H12 MMP C33 047	YELLOW	H4 MMP C4 007	SKY	H74 MMP C368 080
MEDIUM SEA GRAY	H335 MMP C363 094	DARK GREEN	H330 MMP C361 077	OCEAN GRAY	MMP C362 093

F Tempest Mk.V Series 2, EJ536, flown by F/Lt Pierre Clostermann, No. 56 Squadron, B.80 Volkel, the Netherlands, early April 1945

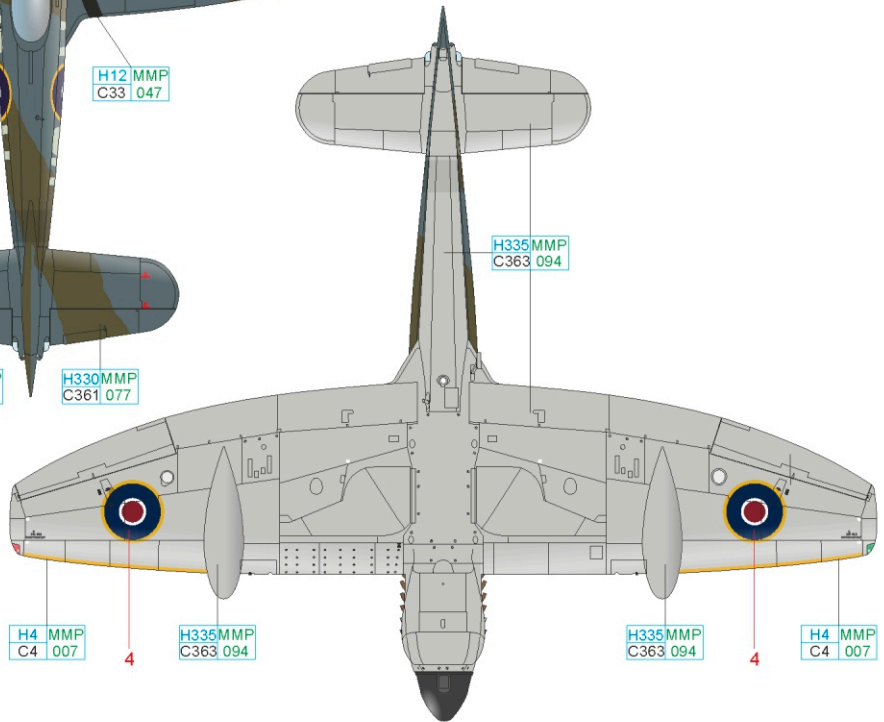
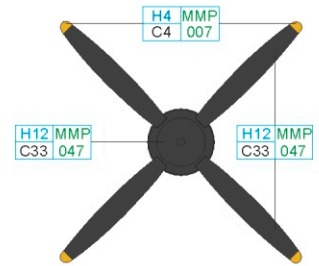
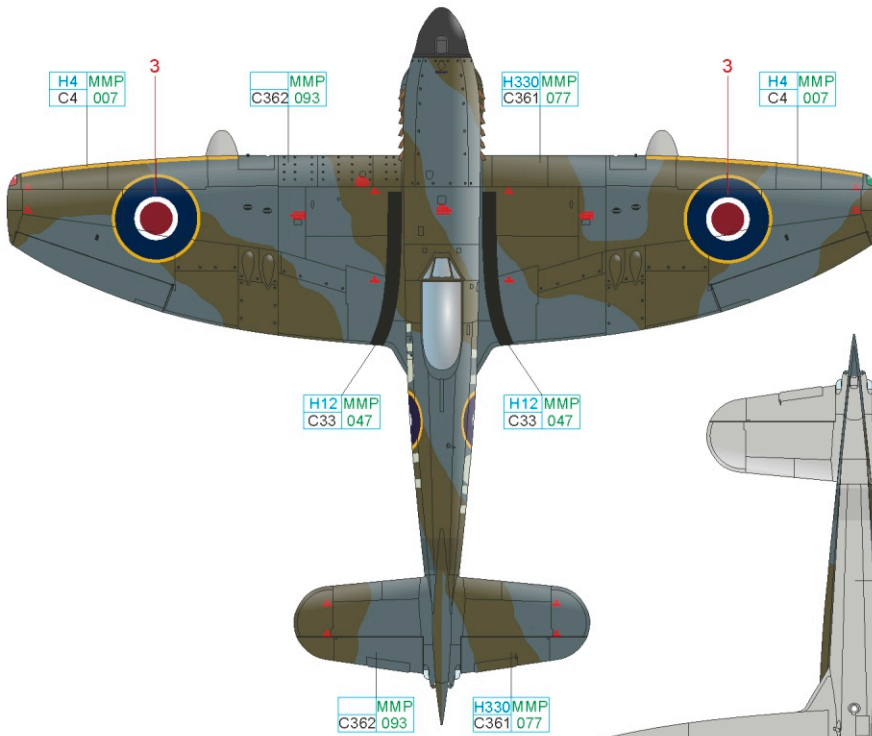
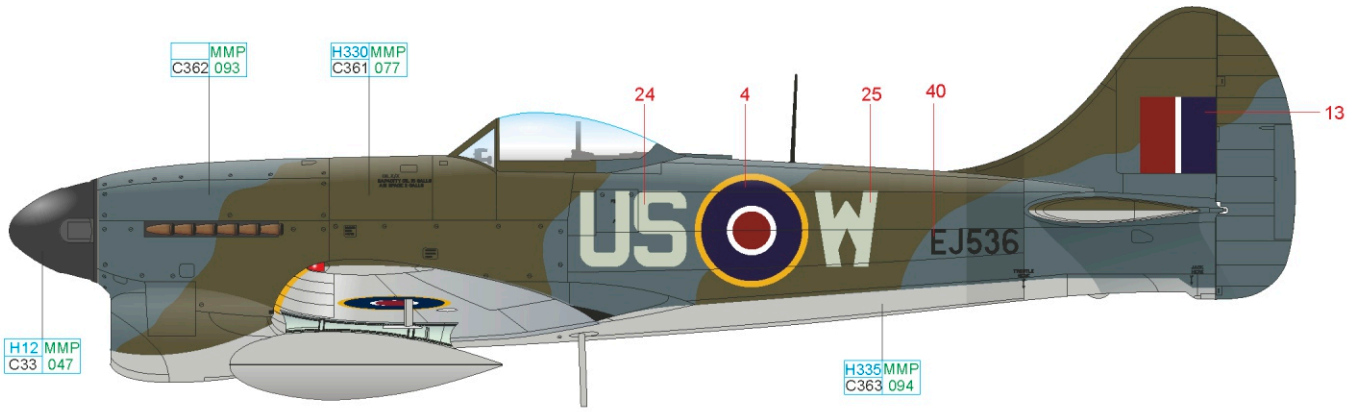

ČESKOU VERZI TEXTU NALEZNETE NA
www.eduard.com
 POD KATALOGOVÝM ČÍSLEM R0018

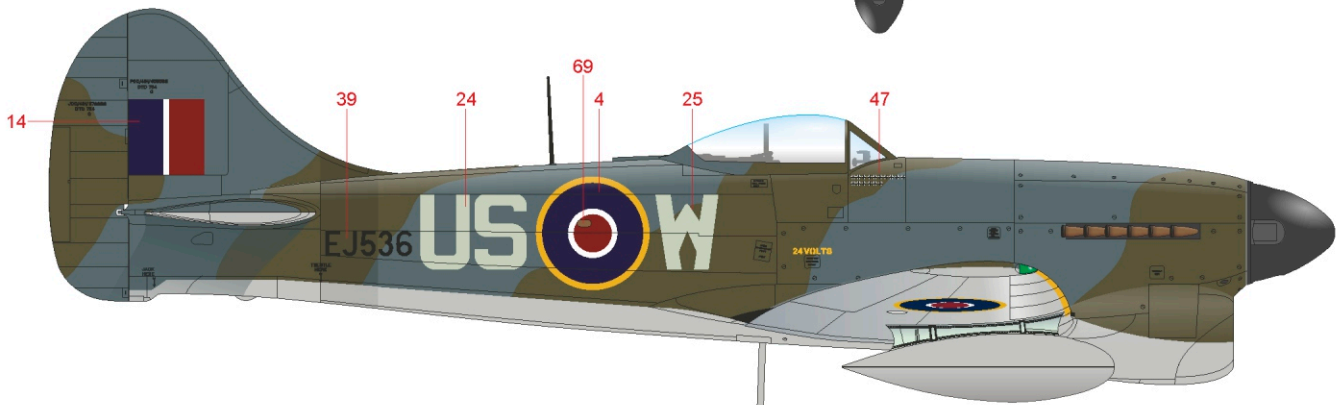

BLACK H12 MMP C33 047 YELLOW H4 MMP C4 007

MEDIUM SEA GRAY H335MMP C363 094 DARK GREEN H330MMP C361 077 OCEAN GRAY MMP C362 093

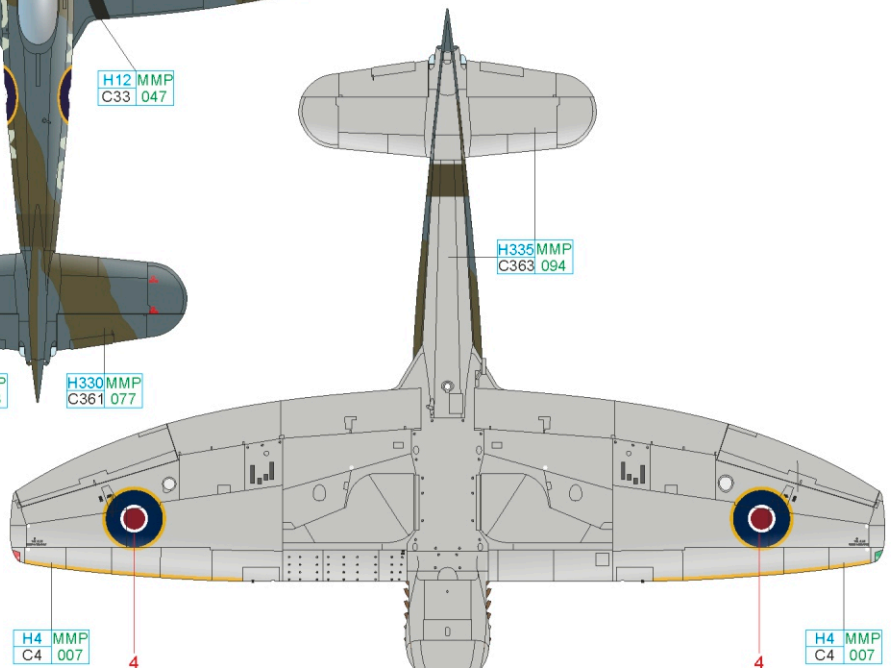
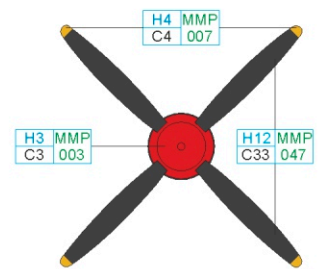
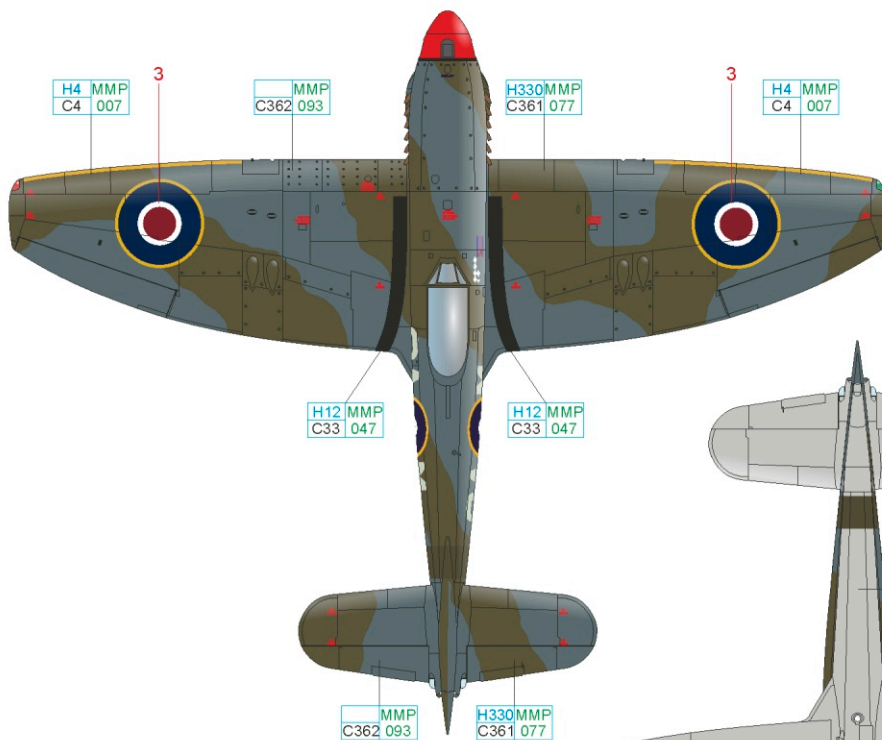
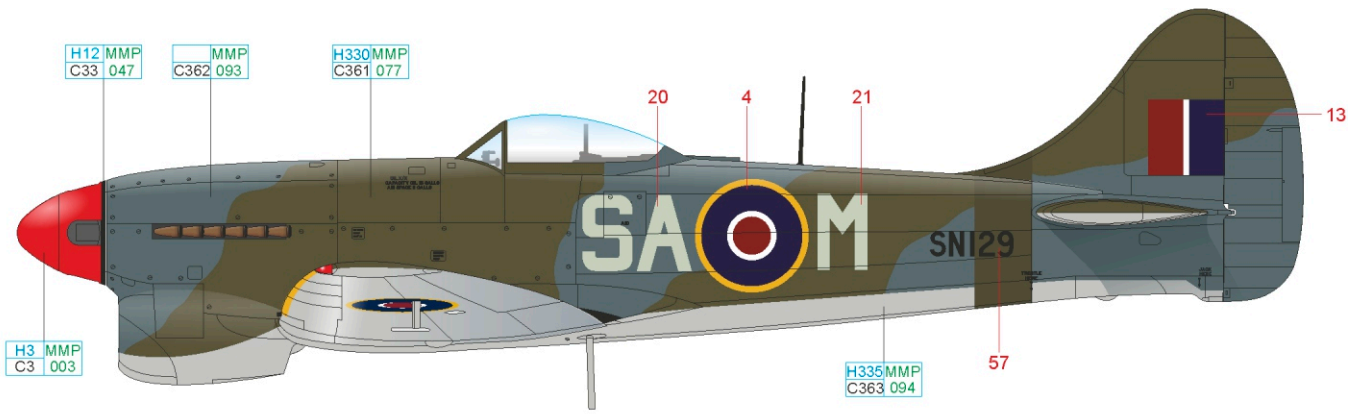

ČESKOU VERZI TEXTU NALEZNETE NA
www.eduard.com
POD KATALOGOVÝM ČÍSLEM R0018

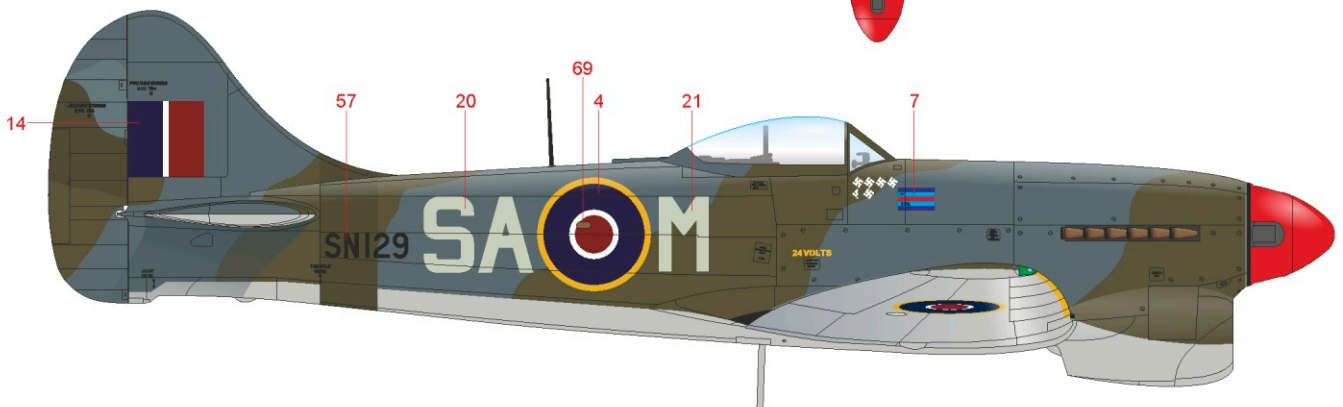

BLACK	H12 MMP C33 047	YELLOW	H4 MMP C4 007	RED	H3 MMP C3 003
MEDIUM SEA GRAY	H335MMP C363 094	DARK GREEN	H330MMP C361 077	OCEAN GRAY	MMP C362 093

H Tempest Mk.V Series 2, NV724, flown by F/Lt Pierre Clostermann, No. 3 Squadron, B.158 Lübeck, Germany, August 1945

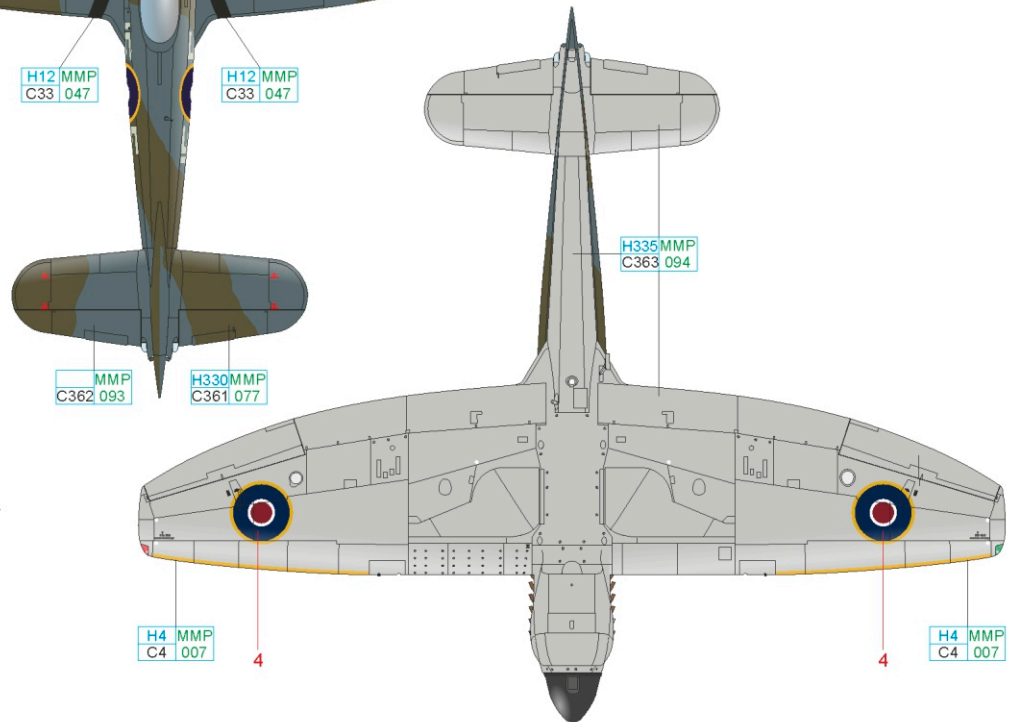
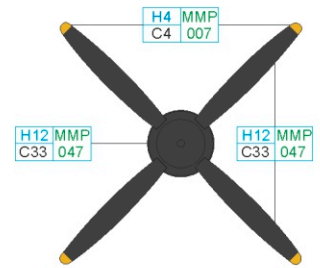
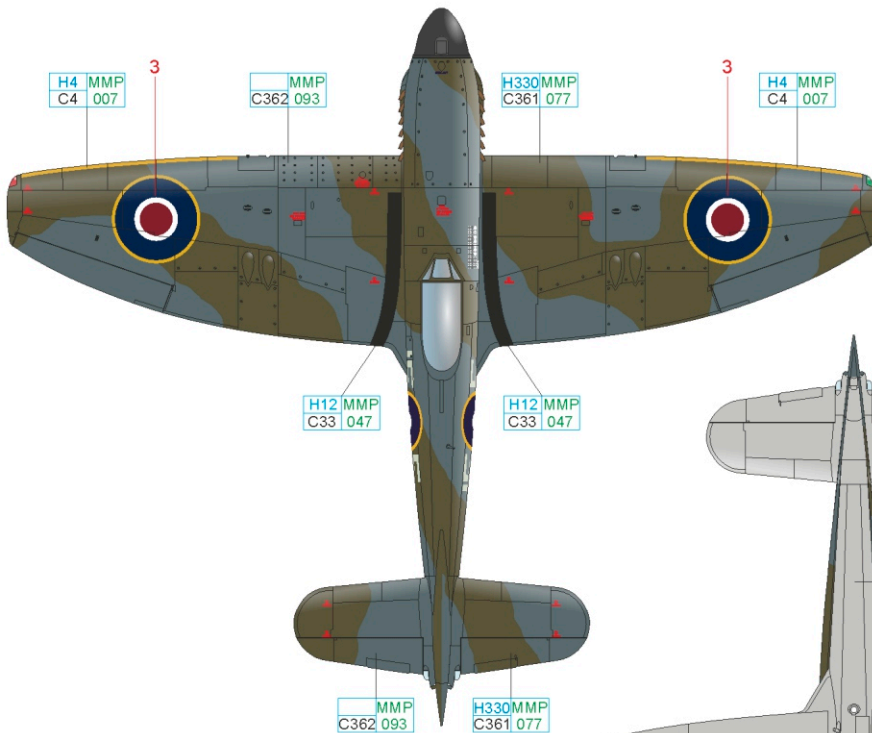
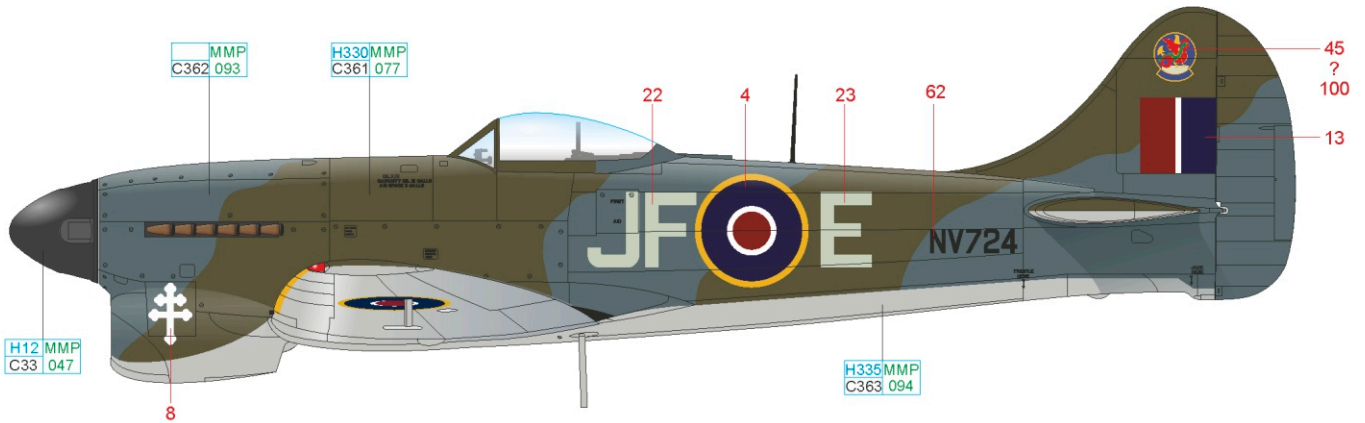

ČESKOU VERZI TEXTU NALEZNETE NA
www.eduard.com
POD KATALOGOVÝM ČÍSLEM R0018

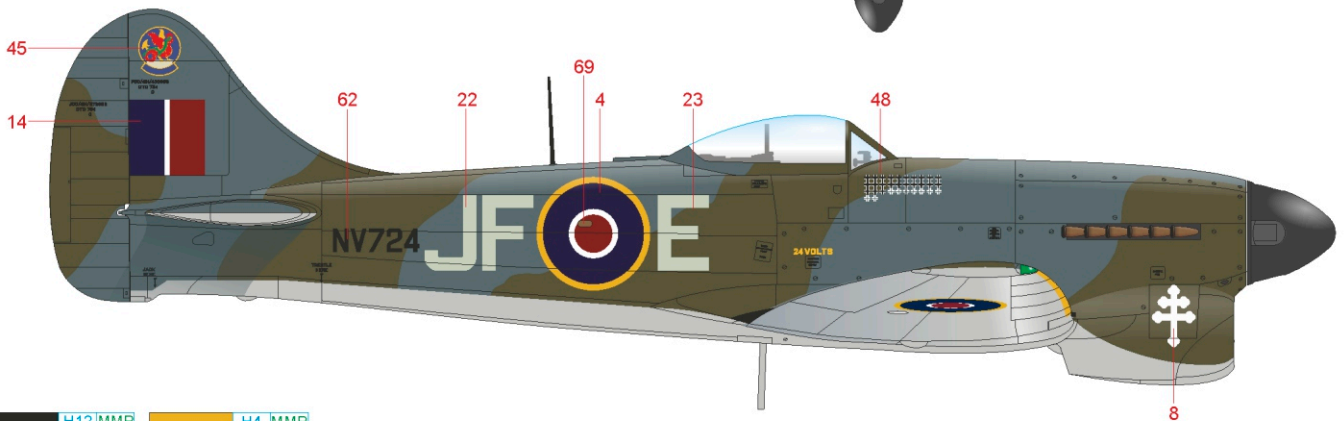

BLACK	H12 MMP C33 047	YELLOW	H4 MMP C4 007
MEDIUM SEA GRAY	H335MMP C363 094	DARK GREEN	H330MMP C361 077
		OCEAN GRAY	MMP C362 093

Tempest Mk.V Series 2, SN228, flown by W/Cdr Ewan D. Mackie, CO of No. 122 Wing, B.160 Kastrup, Denmark, late summer 1945

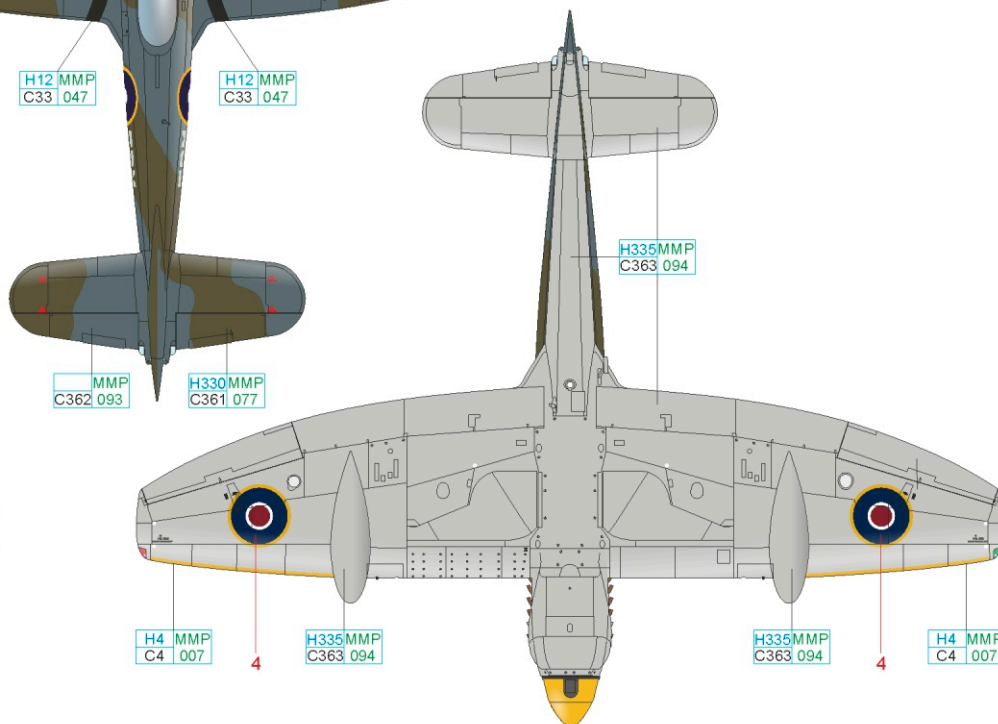
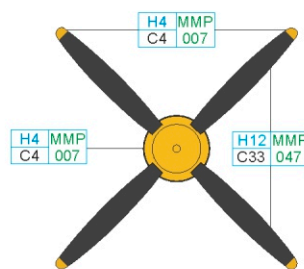
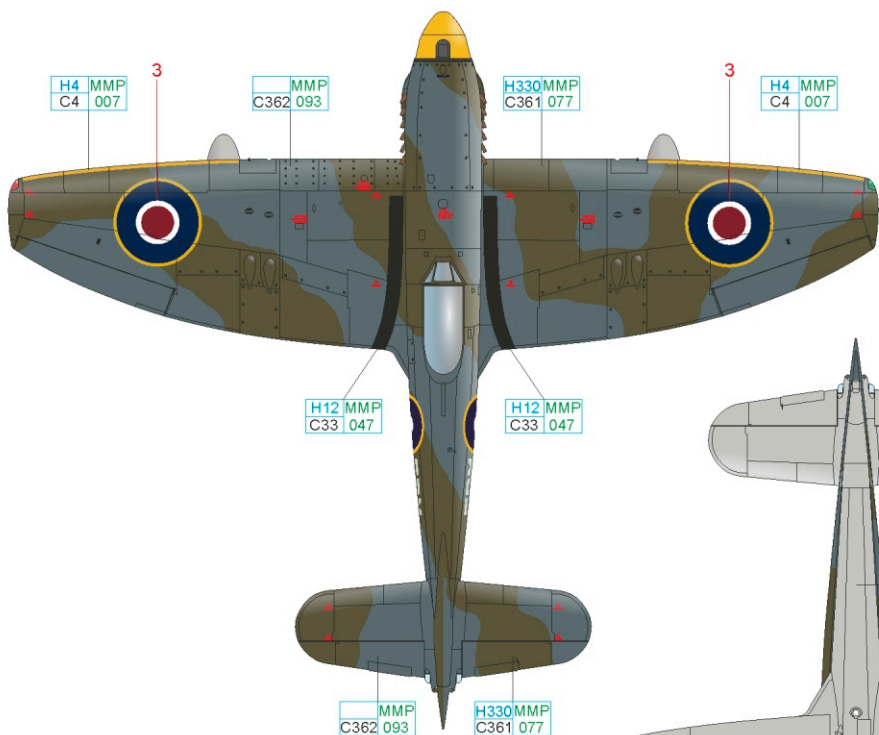
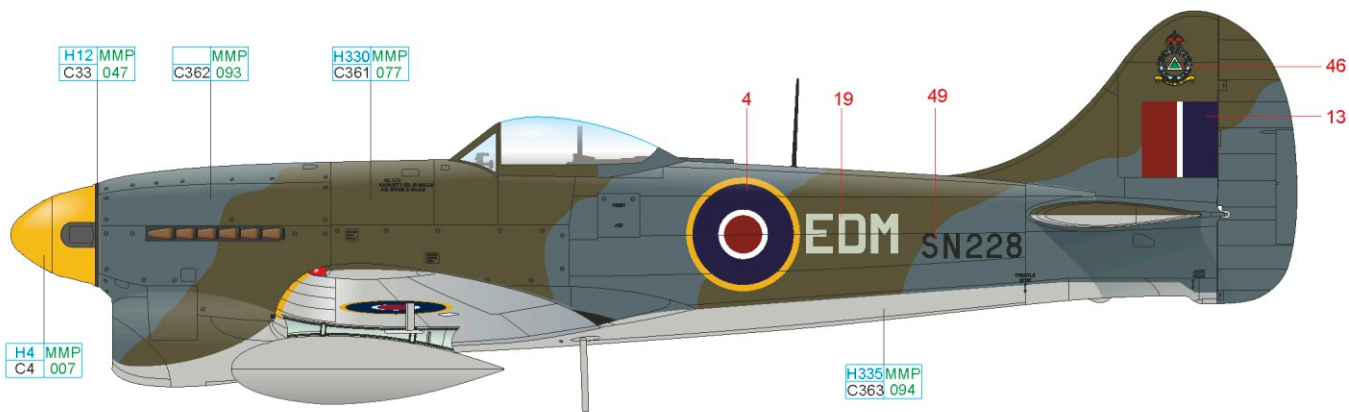

ČESKOU VERZI TEXTU NALEZNETE NA
www.eduard.com
 POD KATALOGOVÝM ČÍSLEM R0018

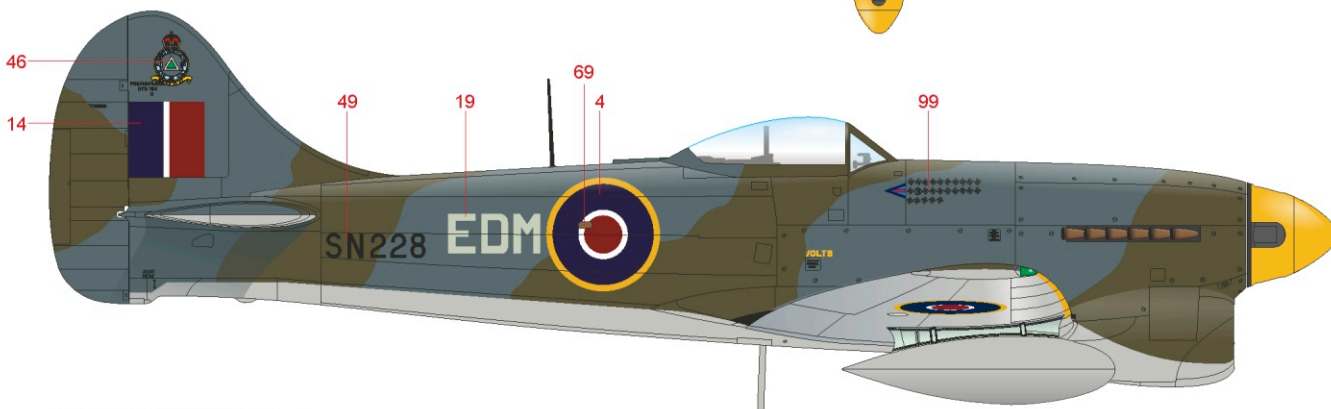

BLACK	H12 MMP C33 047	YELLOW	H4 MMP C4 007
MEDIUM SEA GRAY	H335MMP C363 094	DARK GREEN	H330MMP C361 077
		OCEAN GRAY	MMP C362 093

J Tempest Mk.V Series 2, SN254, flown by S/Ldr. M. P. Killburn, CO of No. 56 Squadron, B.152 Fassberg, Germany, late 1945

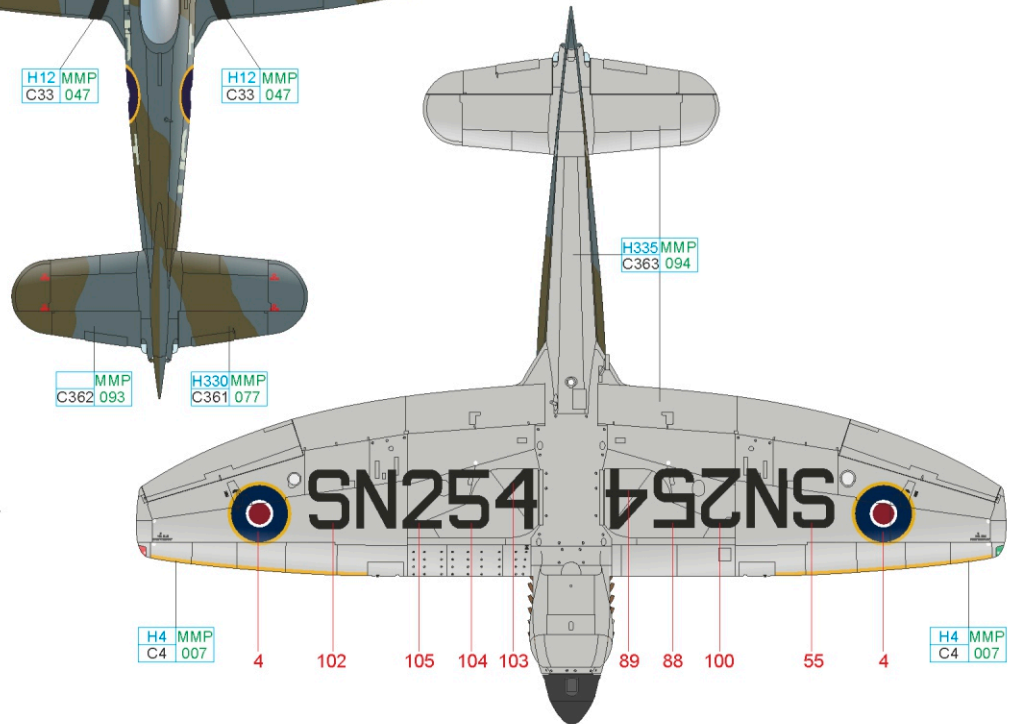
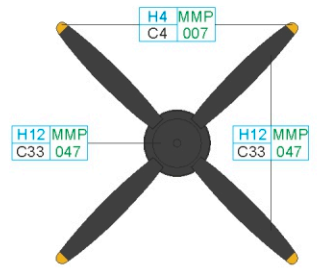
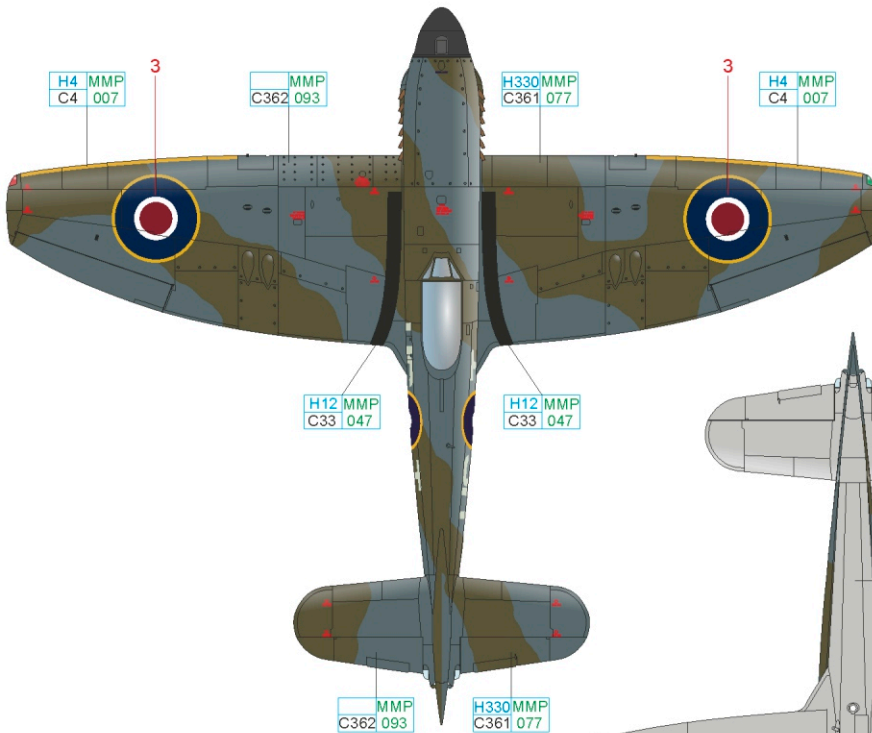
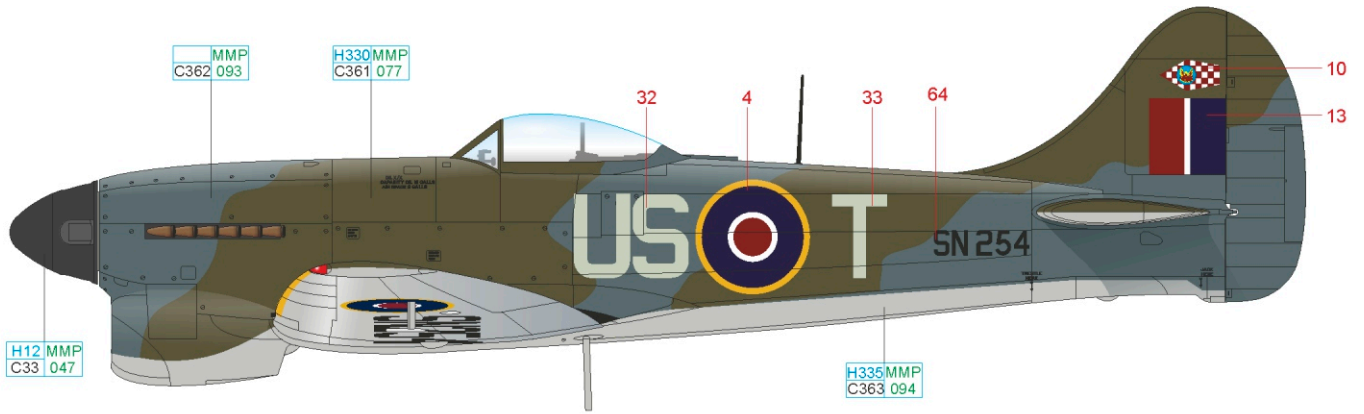

ČESKOU VERZI TEXTU NALEZNETE NA
www.eduard.com
 POD KATALOGOVÝM ČÍSLEM R0018

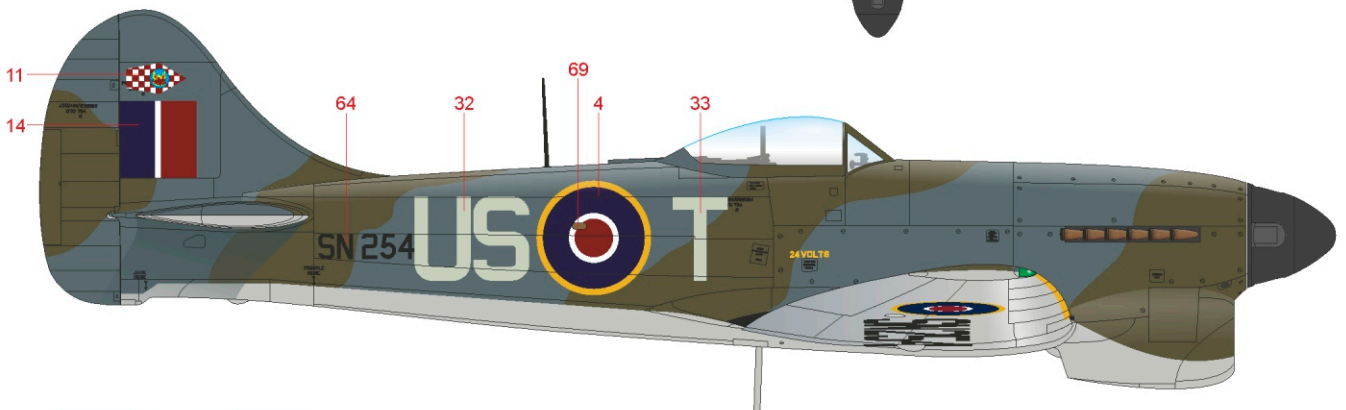

BLACK H12 MMP C33 047 YELLOW H4 MMP C4 007

MEDIUM SEA GRAY H335MMP C363 094 DARK GREEN H330MMP C361 077 OCEAN GRAY MMP C362 093

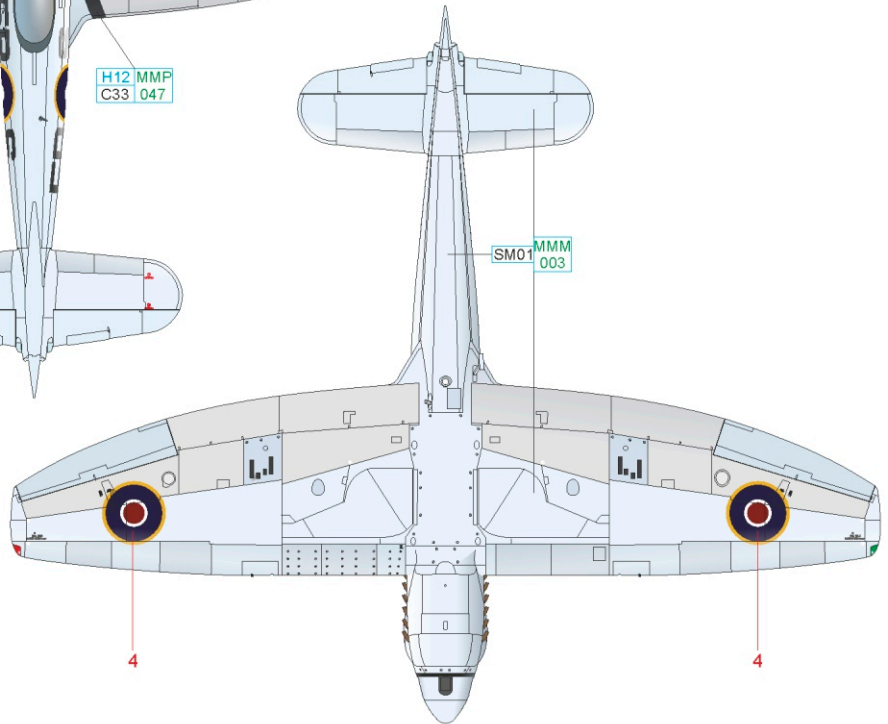
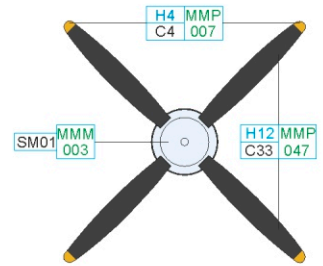
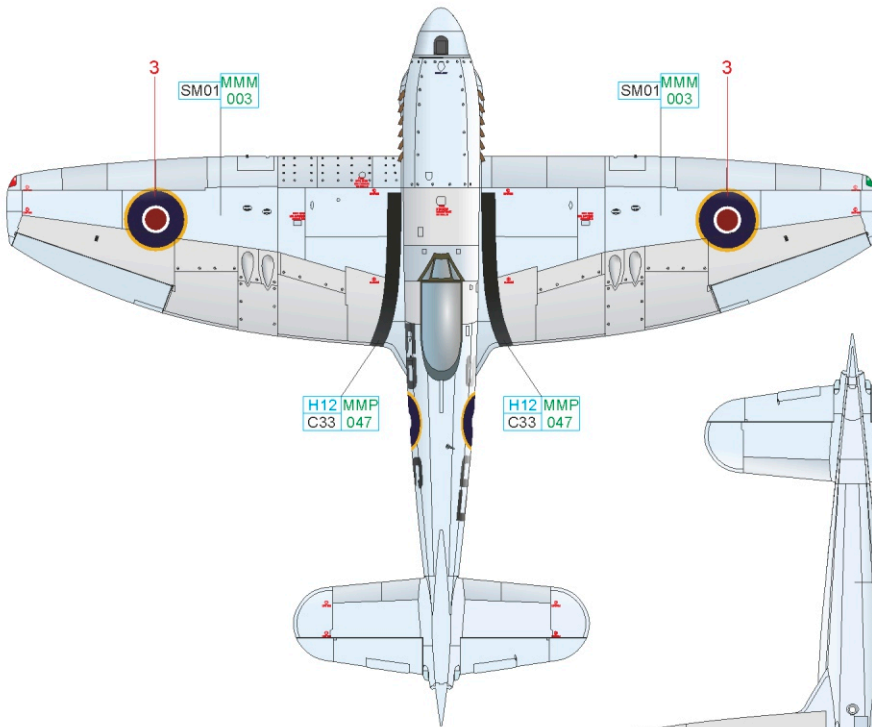
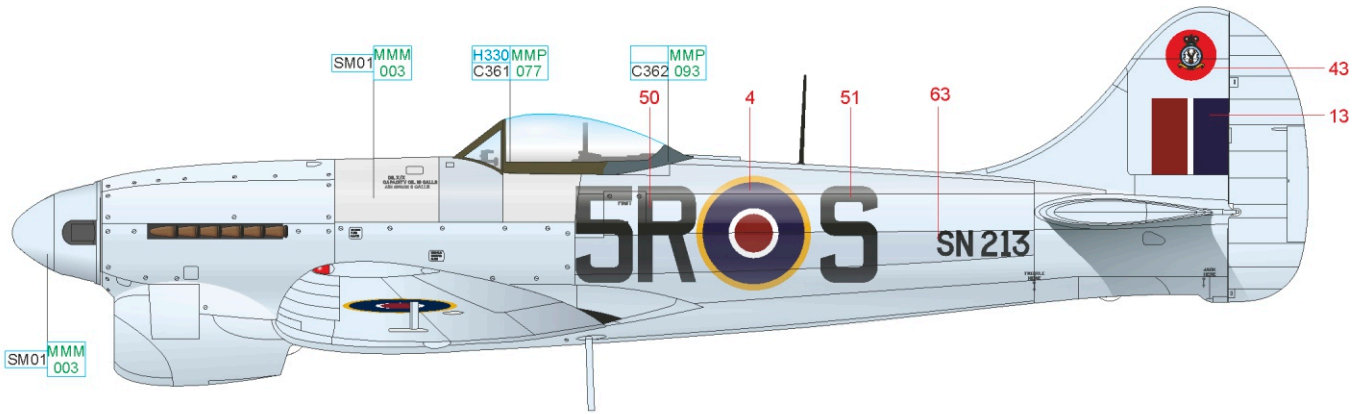

ČESKOU VERZI TEXTU NALEZNETE NA
www.eduard.com
POD KATALOGOVÝM ČÍSLEM R0018

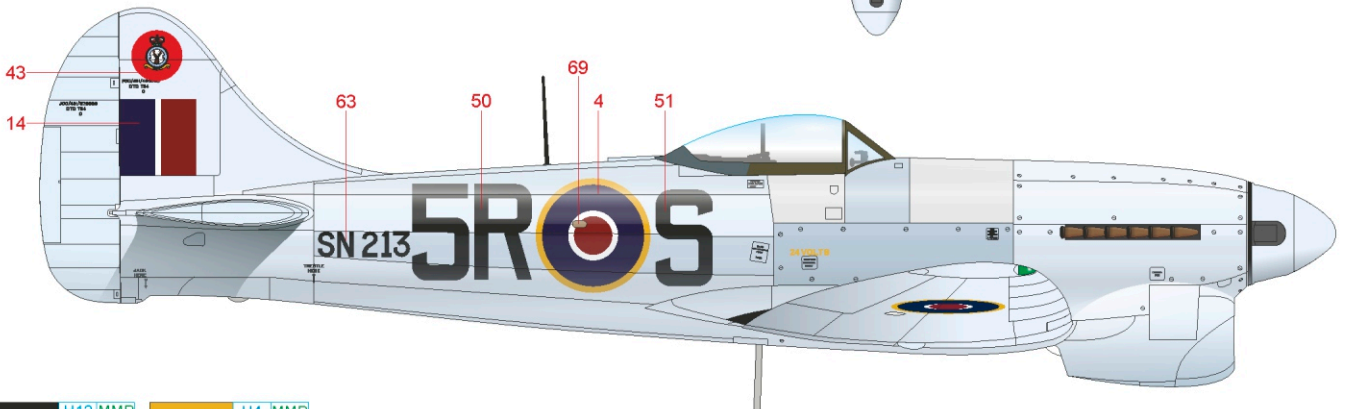

BLACK H12 MMP C33 047 YELLOW H4 MMP C4 007

DARK GREEN H330 MMP C361 077 OCEAN GRAY MMP C362 093 ALUMINIUM SM01 MMM 003

L Tempest Mk.V Series 2, SN330, flown by S/Ldr C. H. Macfie, CO of No. 3 Squadron, Wunstorf, Germany, late 1947

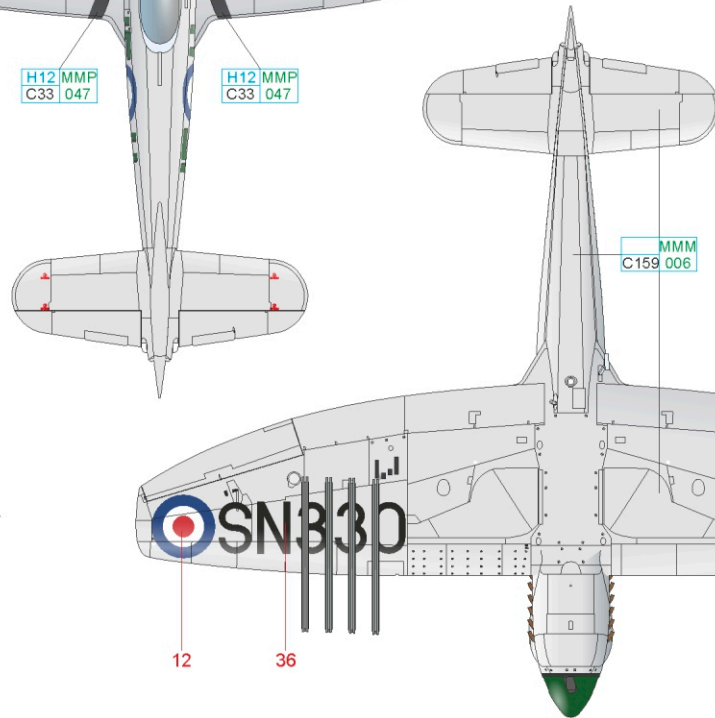
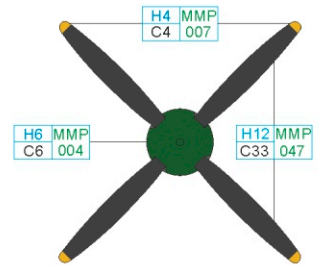
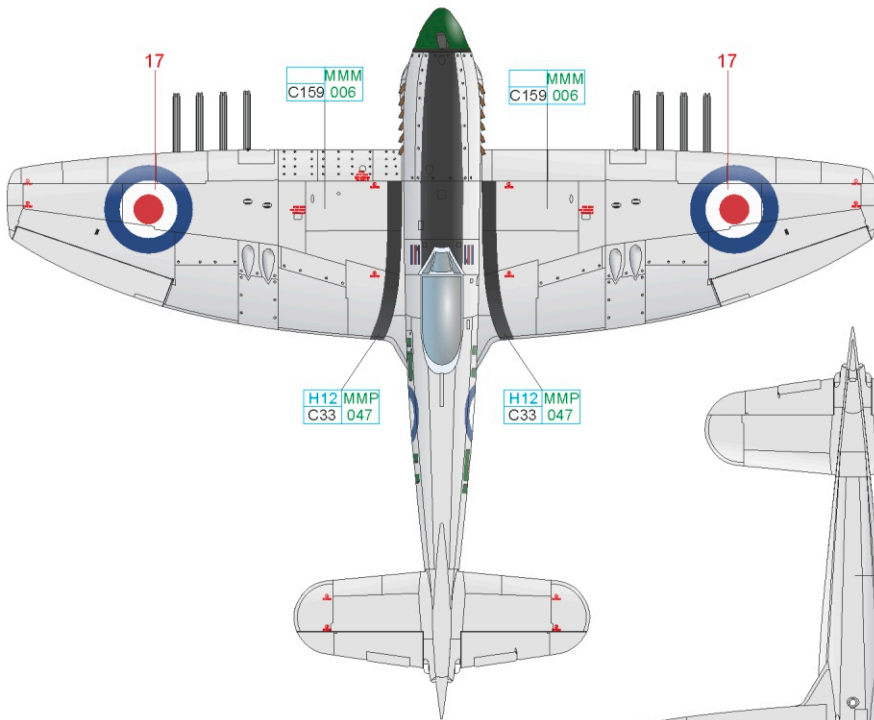
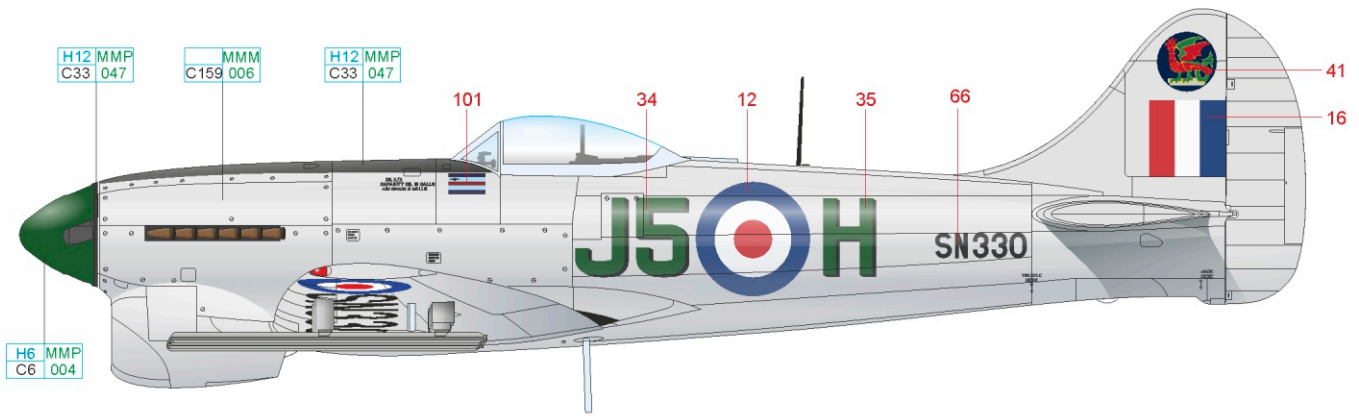

ČESKOU VERZI TEXTU NALEZNETE NA
www.eduard.com
 POD KATALOGOVÝM ČÍSLEM R0018

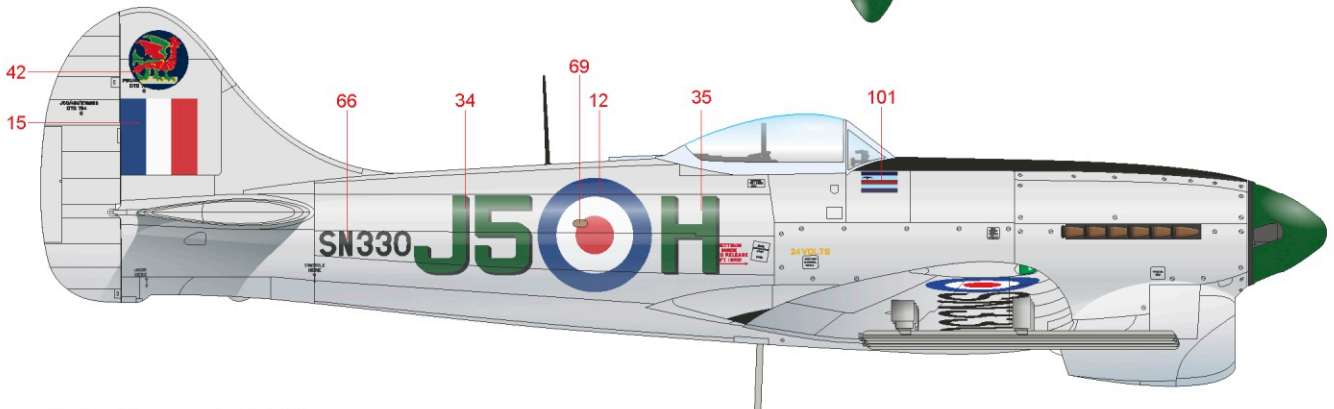

BLACK	H12 MMP C33 047	YELLOW	H4 MMP C4 007
GREEN	H6 MMP C6 004	SILVER	MMM C159 006

M Tempest TT.5, SN261, Central Gunnery School, RAF Station Leconfield, Great Britain, September 1952

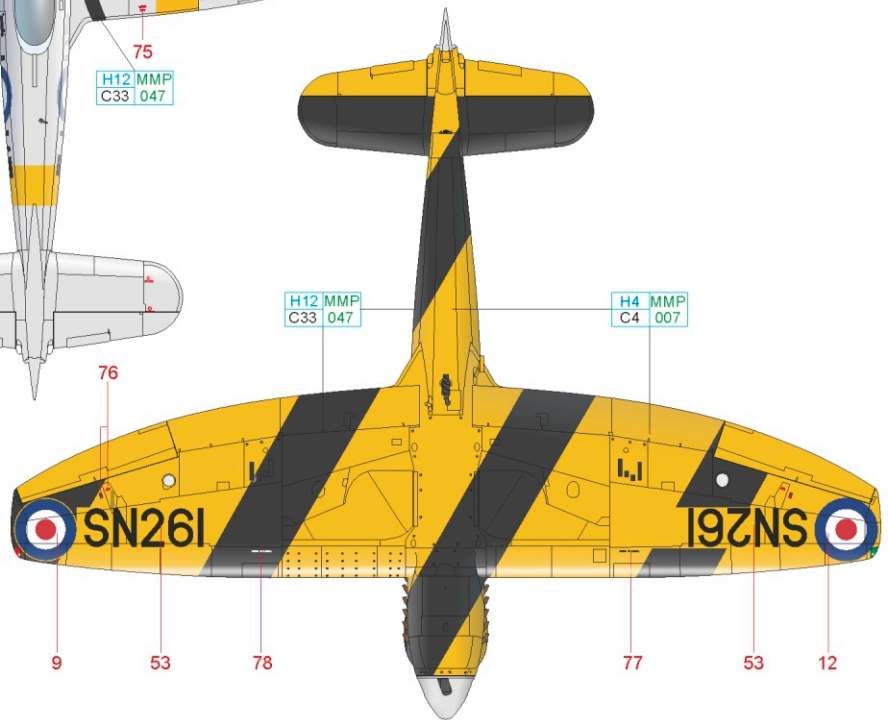
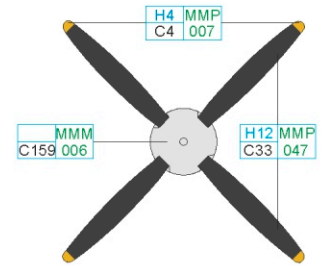
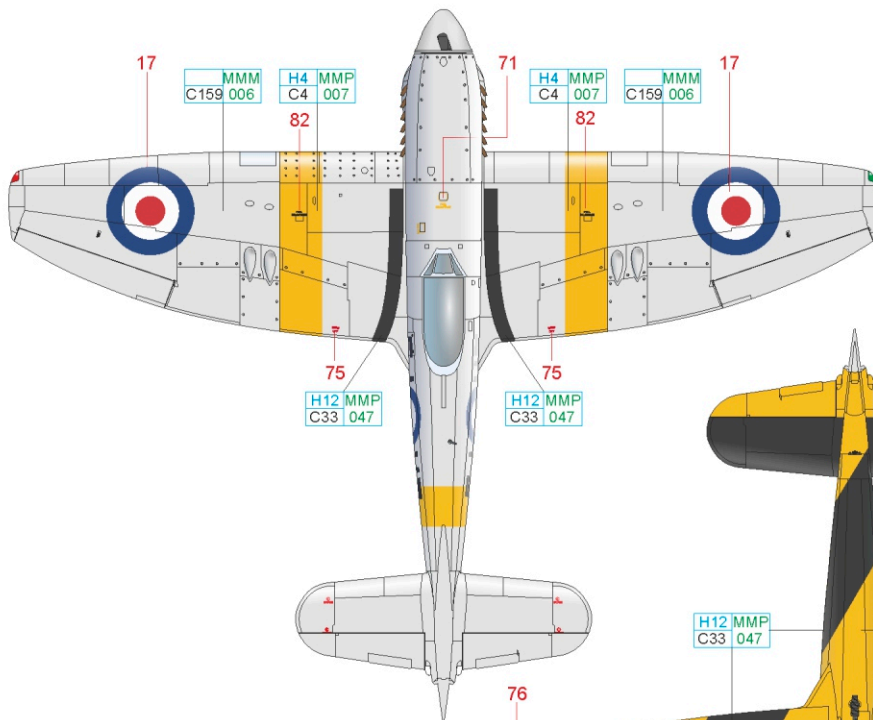
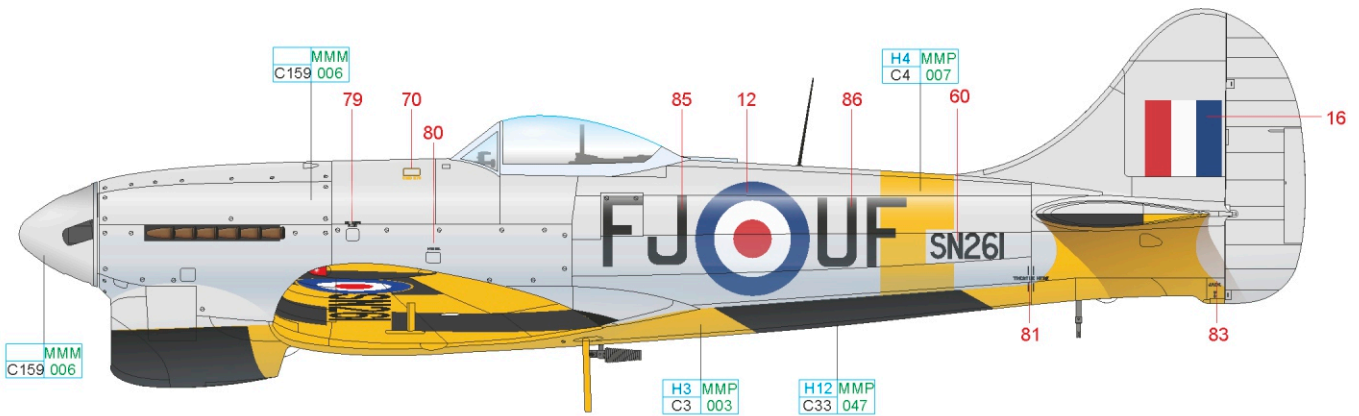

ČESKOU VERZI TEXTU NALEZNETE NA
www.eduard.com
 POD KATALOGOVÝM ČÍSLEM R0018

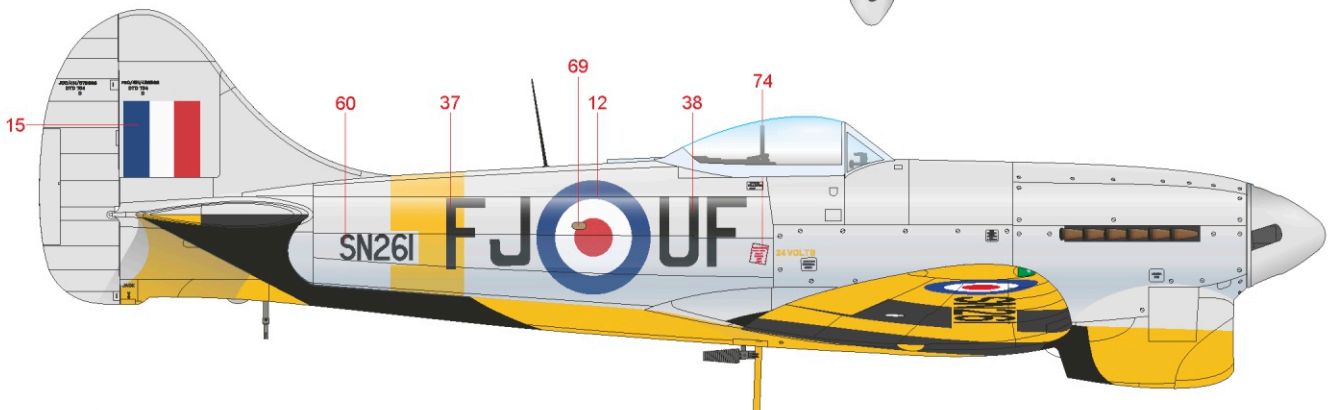

SILVER	MMM C159 006	YELLOW	H4 MMP C4 007
BLACK	H12 MMP C33 047		

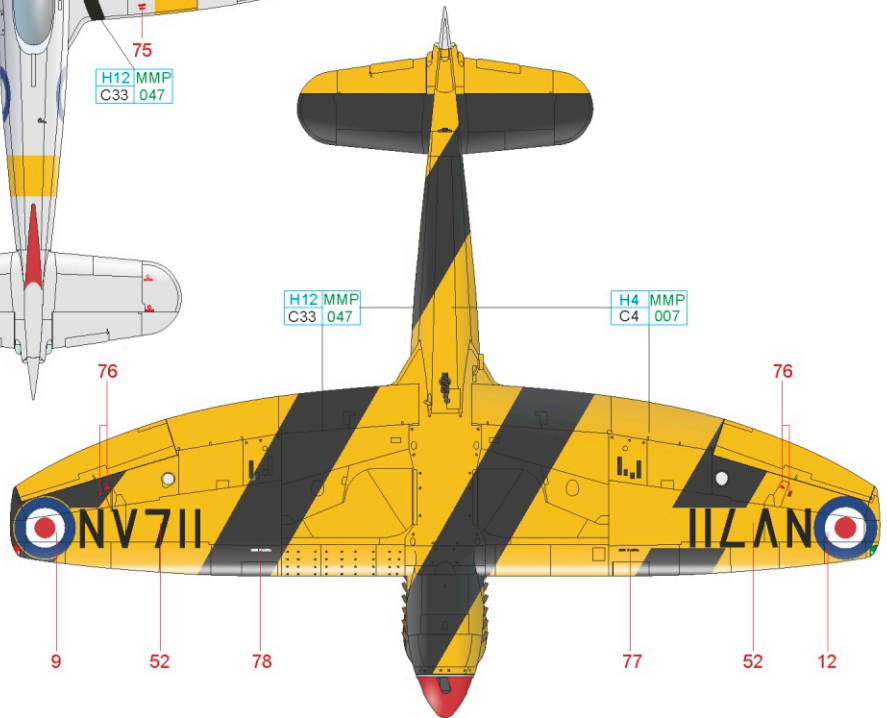
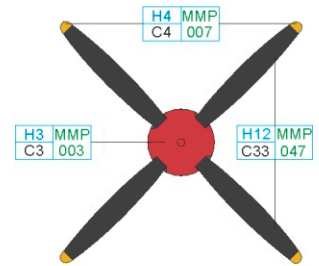
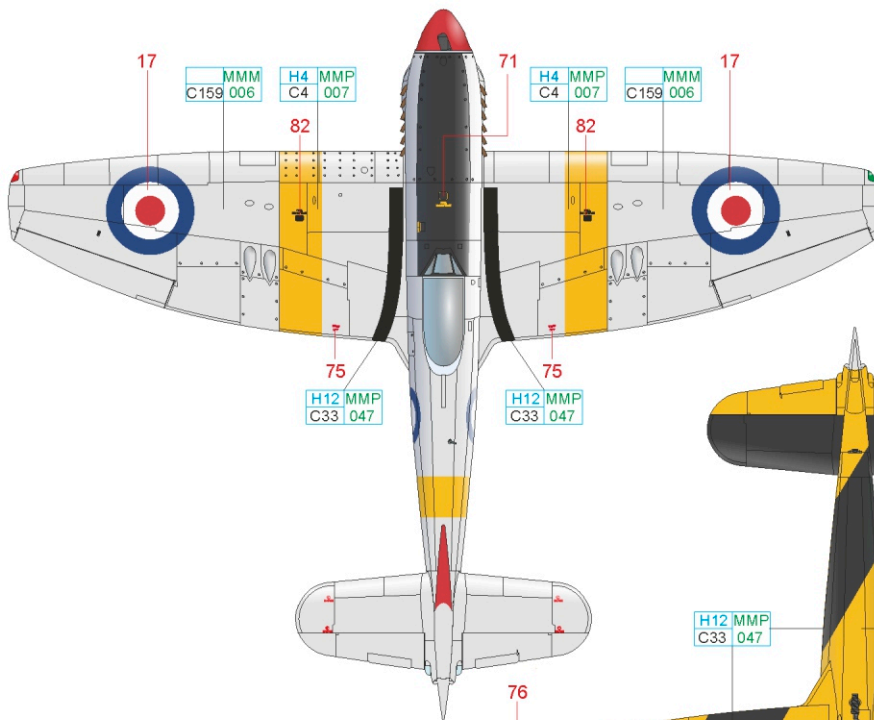
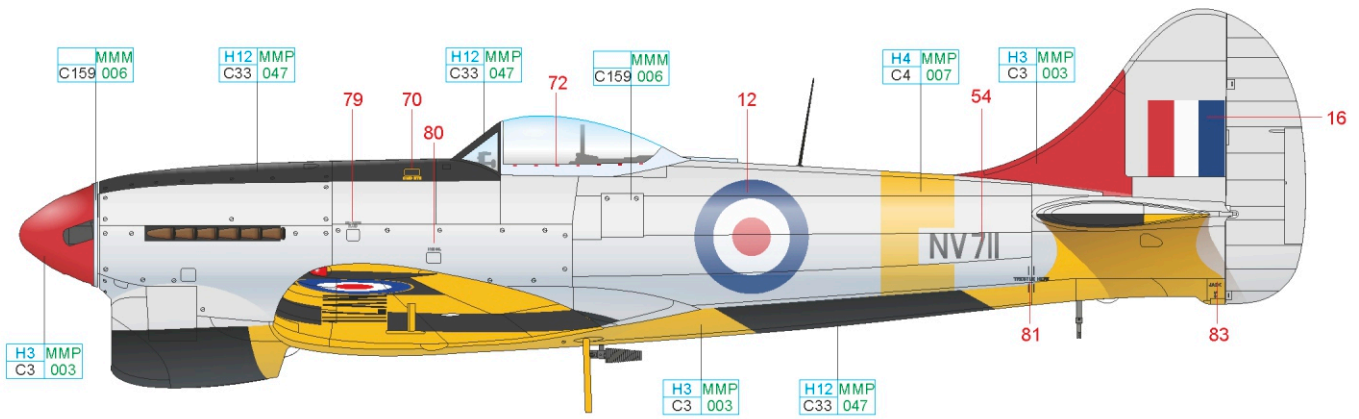

ČESKOU VERZI TEXTU NALEZNETE NA
www.eduard.com
 POD KATALOGOVÝM ČÍSLEM R0018

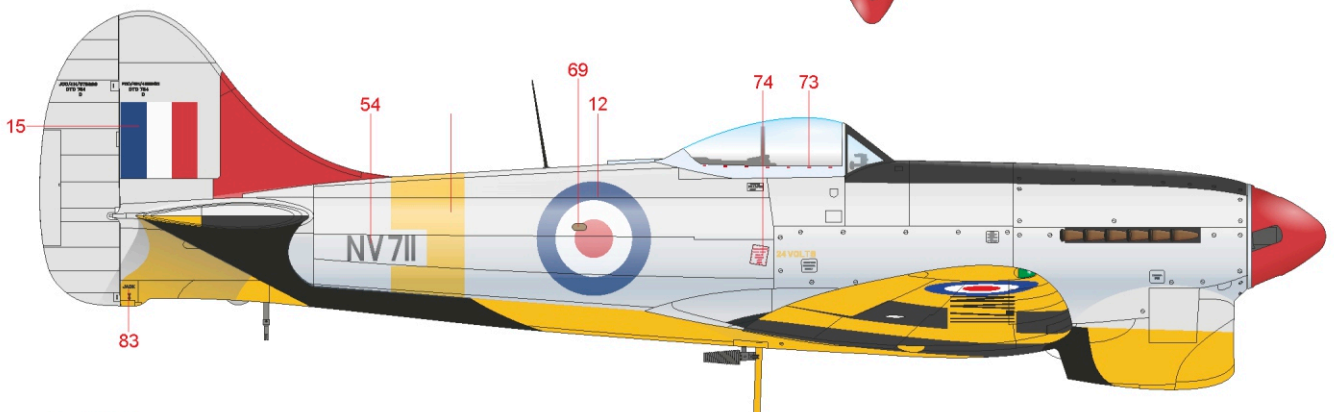

SILVER	MMM C159 006	YELLOW	H4 MMP C4 007	RED	H3 MMP C3 003
BLACK	H12 MMP C33 047				

MARKINGS **A-L** ONLY

